

TO: BOARD OF DIRECTORS
FROM: BRUCE BUEL *BB*
DATE: DECEMBER 7, 2007



AWARD LOW BID FOR PURCHASE OF PICK UP TRUCK

ITEM

Purchase a new 2008 ½ ton pick-up truck adding, one more service vehicle to the District fleet.
[RECOMMEND APPROVAL]

BACKGROUND

The purchase of a 2008 ½ ton pick-up truck was budgeted in the 2007-2008 fixed asset purchases. It was scheduled to replace a vehicle. With the addition of personnel, an additional truck needs to be retained until next year.

Bid specifications for the new truck were faxed to dealers. The dealers and the results are listed below.

Paso Robles Ford	\$22,435.00
Perry Ford	\$19,833.36
Mullahey Ford	\$14,982.56
Kimball Motors	No response
Christianson Chevrolet	No response

RECOMMENDATION

Staff recommends that your Honorable Board award the bid for the purchase of a 2008 ½ ton pick-up truck to Mullahey Ford, with a not-to-exceed expenditure limit of \$14,982.56.

ATTACHMENTS

- Bid specifications faxed to dealers
- Responses from dealers

T:\BOARD MATTERS\BOARD MEETINGS\BOARD LETTER\BOARD LETTER 2007\TRUCK BID.DOC

BIDS FOR THE NEW ½ TON PICK-UP TRUCK

LIST OF BIDDERS:

1. Paso Robles Ford	\$22,435.00 Total
2. Perry Ford	\$19,833.36 Total
3. Mullahey Ford	\$14,982.56 Total
4. Kimball Motors	No Response
5. Christianson Chevrolet	No Response

All the dealers were faxed the bid specifications for the new truck and you have their responses above.

Mullahey Ford has the lowest bid price, availability within four week delivery period.

Please see attached bids and specifications.

NIPOMO COMMUNITY SERVICES DISTRICT

148 So. Wilson St. Nipomo, CA 93444

Phone: (805) 929-1133

Fax: (805) 929-1932

MINIMUM BID SPECIFICATIONS FOR A NEW ½ TON PICK-UP TRUCK

1. New 2008 - ½ Ton Standard Cab with 145" Wheel Base
2. Engine - 4.2 L EFI V-6 (minimum)
3. Exterior - Oxford White
4. Interior - Grey
5. Seating - Bench
6. Transmission - Electronic 4- speed Auto
7. Standard Option Package (inc. air conditioning, radio, etc.)
8. Tow Package and Draw-Tite hitch with receiver
9. Dual Fuel Tanks
10. Bed liner - Line-X
11. Heavy-Duty Suspension

Priced out, itemized, and returned by **11/23/07** including taxes license, delivery charges.

Please mark ATTN: Dan Migliazzo or e-mail to dmigliazzo@ncsd.ca.gov

T:\DOCUMENTS\STAFF FOLDERS\IDAN\TRUCK SPECS 10-07.DOC

*** TX REPORT ***

TRANSMISSION OK

TX/RX NO	4160
RECIPIENT ADDRESS	2392683
DESTINATION ID	
ST. TIME	10/31 11:24
TIME USE	00'27
PAGES SENT	2
RESULT	OK

Dan Migliazzo

From: Jan Shaddox [ford4jan@yahoo.com]
Sent: Monday, November 19, 2007 1:51 PM
To: Dan Migliazzo
Subject: Bid Quote for 2008 1/2 ton Pick-Up truck

Hello Dan Migliazzo,

NIPOMO COMMUNITY SERVICES DISTRICT

Bid for 2008 1/2 ton Standard Cab with 145" wheel base

Engine- 4.2L EFI V6

Exterior- Oxford white

Interior- Grey(flint)

Seating- Bench

Transmission- Electronic 4-speed automatic

Options:

\$850- A/C

\$290- AM/FM radio

\$350- Trailer tow package(XL model with heavy duty payload pkg)

\$95- 35.7 gal fuel tank

\$450- Line X bedliner

Bid Price- \$19,995

Rebates- \$2,500

Sales tax- \$1486.25

Lic fee- \$440.00

Doc fee- \$55

Total out the door- \$22,435.00

Thank you for considering our bid for your 2008 1/2 ton pick-up.
We look forward to earning your business.

Respectfully submitted,
Jan Shaddox
Paso Robles Ford, Lincoln, Mercury
805 239-3673 ext 127
Dated 11/19/2007

Jan Shaddox
Paso Robles Ford
Internet manager
Inventory manager
805 239-3673 ext 127

Never miss a thing. [Make Yahoo your homepage.](#)

*** TX REPORT ***

TRANSMISSION OK

TX/RX NO	4161
RECIPIENT ADDRESS	5447579
DESTINATION ID	
ST. TIME	10/31 12:09
TIME USE	00'36
PAGES SENT	2
RESULT	OK

PERRY

SAN LUIS OBISPO



Jeep

Quote
 To NIPOMO COMMUNITY SERVICES Date 11/7/07
 _____ Attn: DAN MIGLIAZZO
 _____ Phone: _____

Gentlemen: We are pleased to submit a quote on the following equipment:

2008 FORD F150 STANDARD CAB 145'WB
4.2 V6
ELECTRONIC 4 - SPEED AUTO

YOUR FLEET PRICE 20,350
TAX 1580⁶¹
LIC 402⁷⁵
22,333
REBATE - 1000
REBATE - 1500
TOTAL 19,833³⁶

QUOTE GOOD TILL 1/2/08

Vehicles out of stock-subject to prior sale. Prices subject to change by manufacturer prior to ordering. Thank you for the opportunity to submit this quote and we hope we may be of service to you in the future.

Harvey Green
 Harvey Green, Commercial & Leasing Mgr.

11/7/07
 Date

*** TX REPORT ***

TRANSMISSION OK

TX/RX NO	4158
RECIPIENT ADDRESS	4730877
DESTINATION ID	
ST. TIME	10/31 10:05
TIME USE	00'19
PAGES SENT	2
RESULT	OK

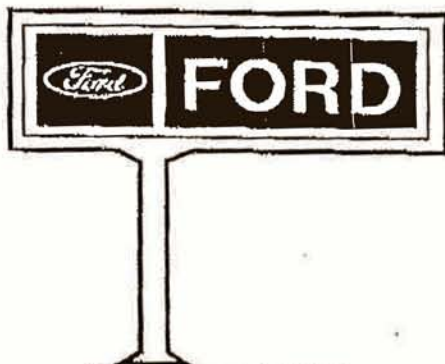

Mullahey Ford

November 16, 2007

To: Nipomo Community Services District
Attn: Dan Migliazzo

RE: Bid on 2008 Ford F150 1/2 ton Pickup Truck

MINIMUM BID SPECIFICATIONS FOR A NEW 1/2 TON PICK-UP TRUCK

- 1. New 2008 - 1/2 Ton Standard Cab with 145" Wheel Base
- 2. Engine - 4.2 L EFI V-6 (minimum)
- 3. Exterior - Oxford White
- 4. Interior - Grey
- 5. Seating - Bench
- 6. Transmission - Electronic 4-speed Auto
- 7. Standard Option Package (inc. air conditioning, radio, etc.)
- 8. Tow Package and Draw-tite hitch with receiver
- 9. Dual Fuel Tanks ****Dual Fuel Tanks Not Available**
- 10. Bedliner - Line-X
- 11. Heavy Duty Suspension ****Heavy Duty Suspension Not Available w/4.2 EFI V-6**

\$13,961.60
 1,012.21 Sales Tax
 8.75 Tire Fee
 14,982.56 OTD

Bo Boco,
Fleet Manager
Mullahey Ford
805-610-5532 cell phone



330 Traffic Way • P.O. Box 578 • Arroyo Grande, CA 93421
(805) 481-FORD (3673) • (805) 929-3218 • FAX (805) 473-0877

Copy of document found at www.NoNewWipTax.com

TO: BOARD OF DIRECTORS
FROM: BRUCE BUEL *BB*
DATE: DECEMBER 7, 2007



AWARD LOW BID FOR PURCHASE OF TRACTOR

ITEM

Purchase a new compact backhoe/tractor [RECOMMEND APPROVAL]

BACKGROUND

The purchase of a backhoe/tractor was budgeted in the 2007-2008 fixed asset purchases.

Bid specifications for a new backhoe/tractor were faxed to dealers. The dealers and the results are listed below.

Berchtold Equipment	No response
Coastal Tractor	Could not meet minimum specifications
Coastline Equipment	\$46, 370.00

RECOMMENDATION

Staff recommends that your Honorable Board award the bid for the purchase of a backhoe/tractor to Coastline Equipment with a not-to-exceed expenditure limit of \$46,370.00.

ATTACHMENTS

- Bid specifications faxed to dealers
- Responses from dealers

T:\BOARD MATTERS\BOARD MEETINGS\BOARD LETTER\BOARD LETTER 2007\TRACTOR BID.DOC

BIDS FOR THE NEW COMPACT TRACTOR

LIST OF BIDDERS:

- | | |
|--------------------|---------------------------|
| 1. Berchtold Eq. | No Response |
| 2. Coastal Tractor | Could not meet min.specs. |
| 3. Coastline Eq. | \$46,370.00 with acc. |

The dealers were faxed the bid specifications for the new tractor and you have their responses above.

Coastline Equipment returned the only bid, availability within four week delivery period.

Please see attached bids and specifications.

I would request the trailer for the transportation of the tractor, be purchased from Coastline Equipment in conjunction with purchase of the tractor. Please see attached quote for the trailer.

NIPOMO COMMUNITY SERVICES DISTRICT

148 SOUTH WILSON STREET
POST OFFICE BOX 326 NIPOMO, CA 93444
(805) 929-1133 FAX (805) 929-1932

DATE: 10/26/07

TO:
Berchfold Equipment
AH Sales Department

FROM:
Dan Migliazzo
Utility Department

THIS TRANSMISSION CONSISTS OF 2 PAGES, INCLUDING THIS COVER SHEET.
IF THERE ARE ANY QUESTIONS, PLEASE CONTACT:

The information contained in this facsimile message is intended for the designated recipient. If the reader of this message is not the intended recipient, you are hereby notified that you have received this document in error, and that any review, dissemination, distribution or copying of this message is strictly prohibited. If you have received this communication in error, please notify us immediately by telephone and return the original message to us by mail.

C\W\FAXFORM

*** TX REPORT ***

TRANSMISSION OK

TX/RX NO	4154
RECIPIENT ADDRESS	3490147
DESTINATION ID	
ST. TIME	10/26 09:04
TIME USE	00'24
PAGES SENT	2
RESULT	OK

NIPOMO COMMUNITY

BOARD MEMBERS

MICHAEL WINN, PRESIDENT
LARRY VIERHEILIG, VICE PRESIDENT
CLIFFORD TROTTER, DIRECTOR
ED EBY, DIRECTOR
JAMES HARRISON, DIRECTOR



SERVICES DISTRICT

STAFF

BRUCE BUEL, GENERAL MANAGER
LISA BOGNUDA, ASSISTANT GENERAL MANAGER
JON SEITZ, GENERAL COUNSEL

148 SOUTH WILSON STREET POST OFFICE BOX 326 NIPOMO, CA 93444 - 0326
(805) 929-1133 FAX (805) 929-1932 Website address: ncsd.ca.gov

To: Sales Department
From: Dan Migliazzo
Date: 10/15/07
Re: Bid Quote for a Compact Backhoe/Tractor

*Sales Personnel,
Please send price quote for a tractor that meets or exceeds the standards below. Please return your quotes no later than 11/16/07.
Thank you for your attention,
Dan Migliazzo – Utility Supervisor NCSD*

BID SPECIFICATIONS FOR A NEW COMPACT BACKHOE / TRACTOR (Minimum Specifications)

1. Must be construction grade tractor with construction grade hydraulics.
2. Must have a fully independent PTO.
3. Engine must have 4 cylinders with self-priming fuel injection.
4. Must be equipped with four-in-one front loader bucket with quick disconnect and blade installed.
5. Must be equipped with quick disconnect backhoe bucket.
6. Backhoe will be equipped with hydraulic thumb and quick disconnections on hoe for hydraulic auxiliary equipment hook-up of (breaker, auger or mower).
7. Must be 4-wheel drive with hydrostatic transmission.
8. Lights must be canopy mounted and consist of head lamps, warning/ brake lamps.
9. Charging system 12volt/55amps and heavy duty 600 CCA battery.
10. Hydraulic system pressure of minimum 2,800 #.
11. Wheels/tires - Front - 10-16.5 8PR Rear – 17.5 x 24 8PR.
12. Cold Start assist – Air preheat coil.
13. Hydraulic pressure minimum of 2900#
14. Fuel tank minimum of 15 U.S. gallons.

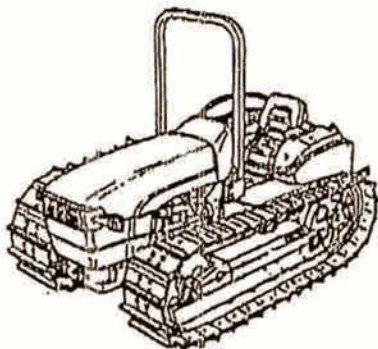
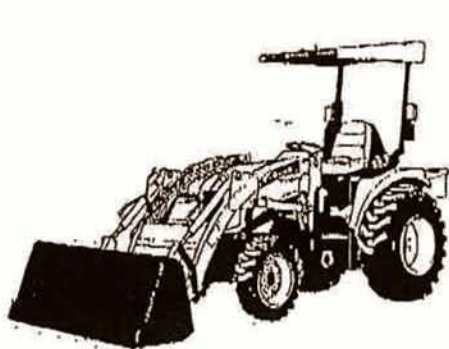

Coastal Tractor
3050 Ramada Dr.
Paso Robles, CA 93944

Parts: <input type="checkbox"/> Larry Shepard <input type="checkbox"/> Oliver Rosa <input type="checkbox"/> Mike Roan Phone: (805)239-5772	Sales: <input type="checkbox"/> Billy Booker <input checked="" type="checkbox"/> Ron Lazzaroni Fax: (805)239-9608	Service: <input type="checkbox"/> Bob Solway
---	---	--

Fax

To: Nipomo Community Dist Attn: Dan Migliazzo

Fax: _____ Pages: _____

Phone: _____ Date: Nov. 6-07

Re: _____ CC: _____

Urgent For Review Please Reply

• Comments:

To Dan Migliazzo
At the present time we can't meet the specifications
for your new compact Backhoe tractor,
Please keep us on your bid list for future Equipment
needs.

Thankyou
Ron Lazzaroni
Coastal Tractor

NIPOMO COMMUNITY

BOARD MEMBERS

MICHAEL WINN, PRESIDENT
LARRY VIERHEILIG, VICE PRESIDENT
CLIFFORD TROTTER, DIRECTOR
ED EBY, DIRECTOR
JAMES HARRISON, DIRECTOR



SERVICES DISTRICT

STAFF

BRUCE BUEL, GENERAL MANAGER
LISA BOGNUDA, ASSISTANT GENERAL MANAGER
JON SEITZ, GENERAL COUNSEL

148 SOUTH WILSON STREET POST OFFICE BOX 326 NIPOMO, CA 93444 - 0326
(805) 929-1133 FAX (805) 929-1932 Website address: ncsd.ca.gov

To: Sales Department
From: Dan Migliazzo
Date: 10/15/07
Re: Bid Quote for a Compact Backhoe/Tractor

Sales Personnel,

Please send price quote for a tractor that meets or exceeds the standards below. Please return your quotes no later than 11/16/07.

Thank you for your attention,

Dan Migliazzo – Utility Supervisor NCS D

BID SPECIFICATIONS FOR A NEW COMPACT BACKHOE / TRACTOR (Minimum Specifications)

1. Must be construction grade tractor with construction grade hydraulics.
2. Must have a fully independent PTO.
3. Engine must have 4 cylinders with self- priming fuel injection.
4. Must be equipped with four-in-one front loader bucket with quick disconnect and blade installed.
5. Must be equipped with quick disconnect backhoe bucket.
6. Backhoe will be equipped with hydraulic thumb and quick disconnections on hoe for hydraulic auxiliary equipment hook-up of (breaker, auger or mower).
7. Must be 4-wheel drive with hydrostatic transmission.
8. Lights must be canopy mounted and consist of head lamps, warning/ brake lamps.
9. Charging system 12volt/55amps and heavy duty 600 CCA battery.
10. Hydraulic system pressure of minimum 2,800 #.
11. Wheels/tires - Front - 10-16.5 8PR Rear – 17.5 x 24 8PR.
12. Cold Start assist – Air preheat coil.
13. Hydraulic pressure minimum of 2900#
14. Fuel tank minimum of 15 U.S. gallons.

NIPOMO COMMUNITY

BOARD MEMBERS

MICHAEL WINN, PRESIDENT
LARRY VIERHEILIG, VICE PRESIDENT
CLIFFORD TROTTER, DIRECTOR
ED EBY, DIRECTOR
JAMES HARRISON, DIRECTOR



SERVICES DISTRICT

STAFF

BRUCE BUEL, GENERAL MANAGER
LISA BOGNUDA, ASSISTANT GENERAL MANAGER
JON SEITZ, GENERAL COUNSEL

148 SOUTH WILSON STREET POST OFFICE BOX 326 NIPOMO, CA 93444 - 0326
(805) 929-1133 FAX (805) 929-1932 Website address: ncsd.ca.gov

To: Sales Department
From: Dan Migliazzo
Date: 10/15/07
Re: Bid Quote for a Compact Backhoe/Tractor

Sales Personnel,

Please send price quote for a tractor that meets or exceeds the standards below. Please return your quotes no later than 11/16/07.

Thank you for your attention,

Dan Migliazzo – Utility Supervisor NCS D

BID SPECIFICATIONS FOR A NEW COMPACT BACKHOE / TRACTOR (Minimum Specifications)

1. Must be construction grade tractor with construction grade hydraulics.
2. Must have a fully independent PTO.
3. Engine must have 4 cylinders with self- priming fuel injection.
4. Must be equipped with four-in-one front loader bucket with quick disconnect and blade installed.
5. Must be equipped with quick disconnect backhoe bucket.
6. Backhoe will be equipped with hydraulic thumb and quick disconnections on hoe for hydraulic auxiliary equipment hook-up of (breaker, auger or mower).
7. Must be 4-wheel drive with hydrostatic transmission.
8. Lights must be canopy mounted and consist of head lamps, warning/ brake lamps.
9. Charging system 12volt/55amps and heavy duty 600 CCA battery.
10. Hydraulic system pressure of minimum 2,800 #.
11. Wheels/tires - Front - 10-16.5 8PR Rear – 17.5 x 24 8PR.
12. Cold Start assist – Air preheat coil.
13. Hydraulic pressure minimum of 2900#
14. Fuel tank minimum of 15 U.S. gallons.

TRAIL KING TRAILERS**FEATURES**

1. Jig Built
2. 100% Primed & Painted Before Decking Installed
(2 Part Polyurethane)
3. One-Piece Continuous Main Frame
4. 4" I-Beam Crossmember
5. Oak deck
6. Torque Flex Axles
7. Truck-Type Wheels and Axles
8. Tilt Trailer Locking Mechanism
9. Adjustable Pintle Hitch
10. Tool box
11. Drop forged D-rings
12. Bolt on Safety Chains
13. 4" Safety headboard
14. Wiring in Plastic Conduit
15. Rubber Grommets Where Wiring Goes Thru Frame
16. Payload Capacity at Highway Speed
17. Reflective Striping
18. Styling
19. 5-year Major Warranty
With 1 Extra Year = If Warranty Card Sent Timely
20. Product Liability Insurance

BENEFITS

- To Maintain Consistent Quality
- Higher Protection Against Corrosion
- Not Spliced, Longer Life, Added Safety
- Not Channel Will not Collect dirt, moisture, or rust out
- Not Pine, Added Value
More Screws to Fight Warping
- Better Ride, Longer Lasting
- Not Mobile Home Axles, Longer Life
- Adjustable to Keep a Snug Fit
- Not Permanently Welded (4 Bolt Attachment)
Fits various Towing Vehicles
- Room for Chains, Etc. Added Value
- Compare Size, Added Safety
Higher Load Capacity Than Competition
- Not Welded to Weaken
- Added Value and Safety
- Adds longer life, less maintenance
Not Steel or Even Worse, Nothing
- Longer Life, Less Maintenance
- Not GVWR, Compare Ratings and MPH
- Twice as Conspicuous, Added Safety
- Pride of Ownership - These Trailers
Are Just Better Looking Than Any
Other Trailer on the Highway
- Coastline Does Factory
Authorized Repairs In-House
- Added Value and Piece of Mind

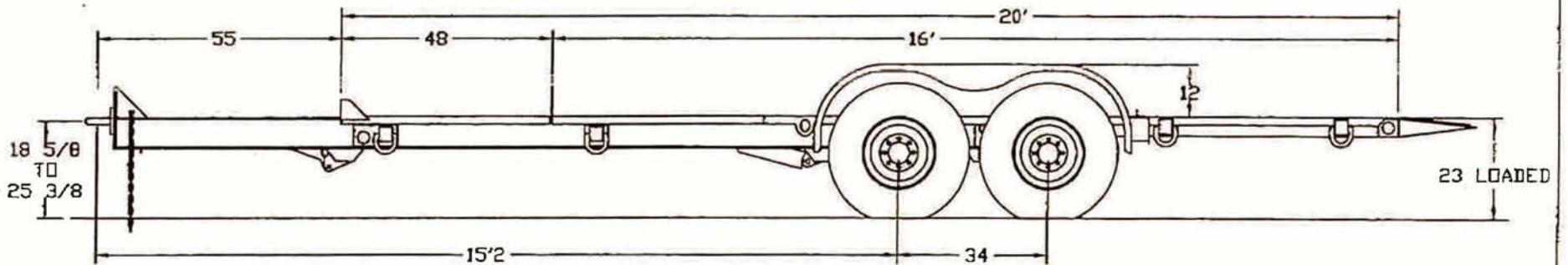
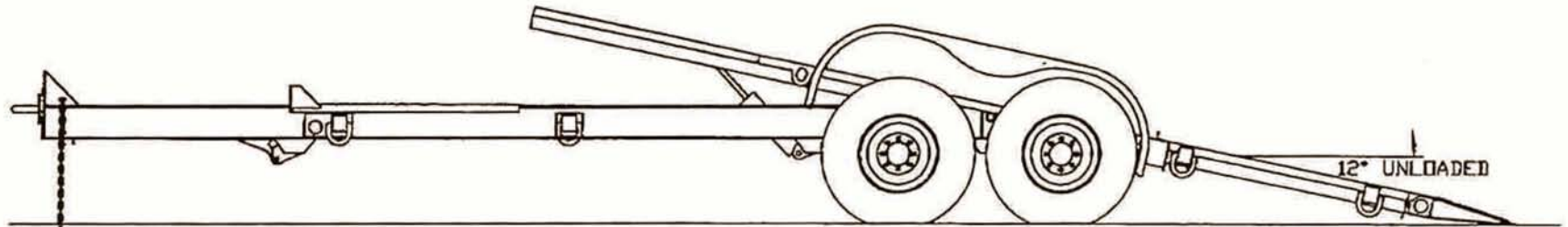

MODEL TKT12U
 CAPACITY 12,000 LBS IN 18 FT
 WIDTH 8'6
 HITCH TONGUE W/ PINTLE EYE
 SUSPENSION.. 6,000 LB TORFLEX
 TIRE SIZE 235/85R X 16
 WHEELS 8 HOLE DISC
 DECKING 1 1/2" RAISED OAK
 OTHER 4' STATIONARY DECK
 16' TILT DECK

ESTIMATED WEIGHT - 4,100 LBS

MODEL TKT12-2000 TRAILER

TRAIL KING INC. INC.

MOX-1064 - MITCHELL ID 57301

DRAWN BY RW	DATE 04/18 2002	IDONT, MA 022340
----------------	-----------------------	---------------------

TO: BOARD OF DIRECTORS
FROM: BRUCE BUEL 
DATE: DECEMBER 6, 2007

**AGENDA ITEM
D-6
DEC. 12, 2007**

**AUTHORIZE EXECUTION OF CONTRACT WITH
LANDSCAPE MAINTENANCE FIRM FOR MAINTENANCE OF OFFICE AND
BLACKLAKE TANK LANDSCAPE**

ITEM

Authorize General Manager to execute a landscape maintenance contract with GLM Landscaping Services. [RECOMMEND ADOPTION].

BACKGROUND

The District contracts weekly landscape maintenance for the District office landscape and Blacklake tank landscape. GLM Landscape Maintenance Service (GLM) has provided landscape maintenance for the District since 2004. GLM currently charges the District \$300 a month for weekly landscaping maintenance of the District office property and \$100 for the Blacklake tank landscape. On October 3, 2007 GLM submitted notice to the District that on January 1, 2008 the charges for landscape maintenance would be \$320 for the District office landscape and \$110 for the Blacklake tank landscape.

To ensure fiscal responsibility, the contract was sent out to bid. Request for Proposals were issued to three landscape maintenance companies. Two companies, GLM Landscape Maintenance Services and Coastland Professional Landscape Services (CPLS), responded.

CPLS's response did not include the required documentation. GLM's response was complete. GLM bid for both sites totaled \$420, and CPLS's bid for both sites totaled \$900 (a \$480 difference).

COMPARISON OF LANDSCAPE MAINTENANCE BIDS		
	GLM	CPLS
Complete Response	Yes	No
Charge for NCSD landscape	\$320	\$400
Charge for Blacklake tank landscape	\$110	\$500
TOTAL	\$420	\$900

After review of the submitted RFPs, GLM offers the best and most complete services, at the lowest cost, and has a ten-year history of successfully providing landscape maintenance services to the District.

RECOMMENDATION

Staff recommends that your Honorable Board authorize the General Manager to execute a three-year contract with GLM Landscape Maintenance Services.