

# NIPOMO COMMUNITY SERVICES DISTRICT

AUGUST 9, 2010, 2:00 PM

## **SPECIAL MEETING NOTICE & AGENDA** **WATER CONSERVATION COMMITTEE**

---

---

### COMMITTEE MEMBERS

MICHAEL WINN, CHAIR  
LARRY VIERHEILIG, MEMBER

### PRINCIPAL STAFF

DON SPAGNOLO, GENERAL MANAGER  
LISA BOGNUDA, ASST. GENERAL MANAGER  
PETER SEVCIK, DISTRICT ENGINEER  
JON SEITZ, GENERAL COUNSEL  
CELESTE WHITLOW, CONSERVATION COORDINATOR

**MEETING LOCATION • District Board Room • 148 S. Wilson Street • Nipomo, California**

**1. CALL TO ORDER, ROLL CALL AND FLAG SALUTE.**

**2. DISCUSS TWO WORKSHOPS, FALL 2010.**

- A. Graywater (limited) Re-Use in Home Landscape, with rebate of \$45 for large brass diversion valve.
- B. Rainwater harvesting, with rebate of \$30 for rainwater harvest barrels, or purchase and sell at cost.

ACTION RECOMMENDED: Provide information. Schedule workshops.

**3. DISCUSS CONSERVETRACK.**

ACTION RECOMMENDED: Provide information on current status. Discussion.

**4. UPDATE: STATE LEGISLATION PERTINENT TO NCSL.**

- A. SB407 (Water-efficient plumbing requirements).
- B. AB 474 (Allows a public agency to enter into a contractual agreement with homeowners for a loan from the agency to finance permanent water-efficiency changes to their property).
- C. AB 1061 (Supports the Model Water Efficient Landscape Ordinance (MWELO) legislation by forbidding a homeowners' association, city, or other common interest development from requiring landscapes which are in conflict with the MWELO).
- D. AB 1366 (Authorizing local agencies providing wastewater treatment services to control salinity inputs from residential self-regenerating water softeners).
- E. SB6X7 (Groundwater monitoring program).
- F. SB7X7 (Defines specifics of requirements and documentation for the "20x2020" program; includes requirements for agriculture).

ACTION RECOMMENDED: Information provided. Discussion.

**5. UPDATES:**

- A. Rebate programs.
  - 1. Turf-Replacement Rebate Program.
  - 2. High-Efficiency Clothes Washer Rebate Program.
- B. Events.
  - 1. CreekDay 2010.
  - 2. Fall Festival 2010.
- D. Public education and outreach.
  - 1. Conservation Newsletter.
  - 2. Newspaper ads.
  - 3. Postcard for Fall Clean-Up Days.
  - 4. OOPs door-hangers.
  - 5. Design, write, obtain quotes for printing, arrange printing and mailing, or other distribution, of brochures, bill inserts, information cards for give-aways (i.e., info cards accompanying with the soil moisture meters), informational hand-outs, Christmas Calendars, etc.

- 6. Conservation web pages.
- 7. Maintain and update display boards in hallway and board room.
- 8. Water Conservation Workshops.
- E. Water audit/survey program.
- G. SLO County Toilet Rebate at Time of Sale program.
- H. SLO County developer contribution to nipomo mesa water conservation area fund for residential water-conservation plumbing and other refits.
- I. NCSD office landscape.
  - 1. Long-Term: Monitor landscape for problems, disease, pests, damage.
  - 2. Long-Term: Rehabilitation into a drought-tolerant education landscape.
  - 3. Short-Term: Replacement of decrepit hedge, north boundary of NCSD office property.
- J. Filing every-two-year report with the California Urban Water Conservation Council on Water Conservation Best Management Practices Status and Progress.
- K. PROFESSIONAL COURSE WORK.  
ACTION RECOMMENDED: Update and discussion.

**6. SET SUBSEQUENT MEETING.**

ACTION RECOMMENDED: Set time/date for next meeting.

**7. ADJOURNMENT.**

*\*\*\* End Special Meeting Notice \*\*\**

TO: COMMITTEE MEMBERS  
FROM: DON SPAGNOLO   
DATE: AUGUST 6, 2010

**AGENDA ITEMS**  
**2**  
**AUGUST 9, 2010**

DISCUSS TWO WORKSHOPS, FALL 2010

**ITEMS**

Discuss two workshops (*Limited Graywater Use in the Home Landscape* and *Rainwater Harvesting*) for Fall 2010.

**BACKGROUND**

Graywater re-use in the landscape and rainwater harvesting for re-use are water conservation tactics in which District customers have expressed an interest.

**RECOMMENDATION**

Discuss potential workshops, provide recommendations.

**ATTACHMENTS**

- *Preface, Certificate of Compliance (Department of Housing and Community Compliance), and Chapter 16A-Nonpotable Water Reuse Systems (Part 1).*
- *San Luis Obispo Guide to Graywater Use*



# NIPOMO COMMUNITY SERVICES DISTRICT

148 SOUTH WILSON STREET  
POST OFFICE BOX 326  
NIPOMO, CA 93444 - 0326  
(805) 929-1133 FAX (805) 929-1932  
Web site address [www.ncsd.com](http://www.ncsd.com)

---

## Water Conservation Committee Meeting Memo

**FROM:** CELESTE WHITLOW, WATER CONSERVATION COORDINATOR  
**TO:** DON SPAGNOLO, GENERAL MANAGER  
**DATE:** 8/6/2010  
**RE:** ITEM 2A: GRAYWATER (LIMITED) RE-USE IN HOME LANDSCAPE, WITH REBATE OF \$45 FOR LARGE BRASS DIVERSION VALVE.

### BACKGROUND

California is faced with a water shortage, and the State of California has made water conservation and water planning top priorities.

NCSD depends on the groundwater basin underlying the Nipomo Mesa for customers' potable water. Other users of this water resource, and NCSD, use more water from the groundwater basin as nature can replenish in a normal year.

NCSD is in the process of bringing water to the Nipomo Mesa from Santa Maria, but actual water delivery is over a year away.

I frequently get inquiries about graywater systems from NCSD customers, who see letting the clothes-washer water go into the sewer as a waste.

Recently the State of California changed the wording of California Plumbing Code (*2007 CPC, Title 24, Part 5, Chapter 16A, Part 1 – Nonpotable Water Reuse Systems*), greatly simplifying the process for homeowners wishing to install a simple graywater system. No permit is required to use a graywater system when connected to your clothes washer. State Public Health has accepted and signed off on the changes.

For further details on the State requirements, please refer to the *Preface, Certificate of Compliance (Department of Housing and Community Compliance)*, and *Chapter 16A-Nonpotable Water Reuse Systems (Part 1)*.

Slogreenbuild, with the guidance of the staff of the San Luis Obispo County Building and Planning Department, Department of Environmental Health, and Public works, and SLO County Supervisor, Jim Patterson, developed a comprehensive guide for homeowners on the safe use of graywater (see *San Luis Obispo Guide to Graywater Use* attached to Item 2A).

Recently I spoke briefly with Supervisor Patterson, who attended a Slogreenbuild two-hour workshop on the simplified graywater system requirements, and he expressed his informational and other support of facilitating SLO County residents who are so inclined in adding graywater use to their water conservation measures used in their home and landscape.

### RECOMMENDATIONS FOR CONSIDERATION

Conduct an informational workshop in Fall 2010 on "limited" graywater use, focusing on using a home's noncontaminated clothes-washer graywater for irrigation of the home's non-root-vegetable-crop landscape.

Such a workshop would be a centralized introduction for interested NCSD customers, and others, if appropriate. Knowledgeable people would be able to answer questions or give advice on graywater systems. Providing a workshop for our customers would demonstrate NCSD's commitment to helping them conserve water, and would demonstrate NCSD's leadership in bringing information to them on water conservation.



Consider offering a \$45 rebate to cover the high-ticket-item part of a home graywater system: the brass diverter valve by which, should the clothes-washer water be contaminated (i.e., from washing baby diapers or bleach), the user of the system can switch from graywatering the landscape to sending the graywater into the septic system or sewer system.

### ATTACHMENTS

- *Preface, Certificate of Compliance (Department of Housing and Community Compliance), and Chapter 16A-Nonpotable Water Reuse Systems (Part 1).*
- *San Luis Obispo Guide to Graywater Use*



# NIPOMO COMMUNITY SERVICES DISTRICT

148 SOUTH WILSON STREET  
POST OFFICE BOX 326  
NIPOMO, CA 93444 - 0326  
(805) 929-1133 FAX (805) 929-1932  
Web site address [www.ncsd.com](http://www.ncsd.com)

## Water Conservation Committee Meeting Memo

**FROM:** CELESTE WHITLOW, WATER CONSERVATION COORDINATOR  
**TO:** DON SPAGNOLO, GENERAL MANAGER  
**DATE:** 8/5/2010  
**RE:** ITEM 2B: RAINWATER HARVESTING, WITH REBATE OF \$30 FOR RAINWATER HARVEST BARRELS, OR PURCHASE AND SELL AT COST.

### BACKGROUND

California is faced with a water shortage, and the State of California has made water conservation and water planning top priorities.

Rainwater harvesting has become a popular option for water conservation because of generalized interest in water conservation, and because of the unique qualities of rainwater.

Rainwater harvesting is a form of stormwater reuse/recycling, usually practiced on a small scale by homeowners. Rainwater harvesting is the process of intercepting stormwater runoff from a surface (e.g. roof, parking area, land surface), and putting it to beneficial use. Intercepted stormwater can be collected, slowed down, and retained or routed through the site landscape using cisterns, microbasins, swales and other water-harvesting structures. Water harvesting reduces dependence on dwindling groundwater resources and expensive imported water. Capturing and using stormwater runoff also reduces the need for discharge from the site, and the potential transport of stormwater pollution.



Rainwater-harvesting systems can be found in all shapes, sizes and configurations, from a simple catchment system under a downspout to large above-ground or underground cisterns with complicated filtration systems able to store thousands of gallons of water. Most rainwater collection systems are comprised of the following basic parts:

- **Catchment surface**, such as a rooftop or other raised solid surface. It is generally agreed that the best catchment systems have hard, smooth surfaces, such as metal roofs or concrete surface. The amount of water harvested depends on how much rain falls, and the size of the surface and slope of the catchment area.
- **Gutters and downspouts**, which are also known as distribution systems, which channel the water from the catchment area to a holding container (barrel, cistern, planted area, etc.).
- **Leaf screens**, which is a screen which removes or catches debris.
- **Roof washers**, a device diverting the first flush of rain before it enters the storage tank. Most rainwater suppliers recommend the diversion of the first flush of water to an outside area of the storage system, since the catchment surface may accumulate bird droppings, debris and other pollution.
- **Storage tanks**. In general, the storage tank is the most expensive part of a rainwater harvesting system. There are many types and styles of storage tanks available. Storage can be above-ground or underground. Storage containers can be made from galvanized steel, wood, concrete, clay, plastic, fiberglass, polyethylene, masonry, etc. Examples of above-ground storage include cisterns, barrels, tanks, garbage cans, above-ground swimming pools, etc. Storage tank prices vary based on different variables, such as size, material and sophistication. To inhibit the growth of algae, storage tanks should be opaque and preferably placed away from direct sunlight. The tanks should also be placed close to the areas of use and supply line to reduce the distance over which the water is delivered.
- **Delivery systems** include gravity-fed or pumped delivery systems to deliver the rainwater to the landscape or other areas where it will be used.
- **Purification/treatment system** is needed for systems to be used for potable water to make the water safe for human consumption.



#### **Benefits of rainwater harvesting.**

- Makes use of a natural resource and reduces flooding, stormwater runoff, erosion, and contamination of surface water with pesticides, sediment, metals, and fertilizers
- Reduces the need for buying potable water from a water purveyor, with the potential to decrease homeowner water bills.
- Generally, a good source of water for landscape irrigation.
- Home systems can be relatively simple to install and operate.
- Promotes both water and energy conservation
- No filtration system required for landscape irrigation

#### **Disadvantages of rainwater harvesting.**

- Limited and uncertain local rainfall.
- In Mediterranean climates, rainfall occurs in the cool, winter months, when demand for landscape water is often satisfied by rainfall.

- Sophisticated systems can be costly to install.
- The payback period varies depending on the size of storage and complexity of the system.
- Can take considerable amount of time to “pay for itself.”
- Requires some technical skills to install and provide regular maintenance.
- If not installed correctly, may attract mosquitoes (i.e.; West Nile disease and other waterborne illnesses).
- Certain roof types may seep chemicals, pesticides, and other pollutants into the water that can harm the plants.

### **RECOMMENDATIONS FOR CONSIDERATION**

Conduct an informational workshop in Fall 2010 on rainwater harvesting, with a \$30 rebate on purchase of a rain barrel or other system.

Such a workshop would be a centralized introduction for interested NCSD customers, and others, if appropriate. Knowledgeable people would be able to answer questions or give advice on rainwater harvesting. Providing a workshop for our customers would demonstrate NCSD's commitment to helping them conserve water, and would demonstrate NCSD's leadership in bringing information to them on water conservation.

### **ATTACHMENTS**

None.

*T:\BOARD MATTERS\BOARD MEETINGS\BDMEMO\080910-GRAYWATERWORKSHOP.DOC*



## PREFACE

### **INTRODUCTION**

Chapter 16A establishes minimum requirements for the installation of graywater systems in occupancies regulated by the Department of Housing and Community Development (HCD). It is intended to provide guidance to code users while providing flexibility that will encourage the use of graywater. This chapter contains provisions which allow the installation of limited types of graywater systems to be installed without a construction permit. It is not the intent of HCD that the exemption from a construction permit be construed by code users as an exemption from the provisions of this chapter or other lawfully enacted requirements imposed by a city, county, or city and county, nor does it eliminate the need for persons considering the installation of a graywater system from contacting local authorities to ensure they are adequately informed about any local requirements or prohibitions.

### **DEVELOPMENT**

This chapter was developed through input from stakeholders representing a wide variety of interests during several public meetings. These meetings resulted in several drafts, which were distributed to stakeholders for comment. HCD considered these comments and did extensive research on graywater use. Toward the end of the development stage, HCD made a decision to propose these standards on an emergency basis in order to allow the regulations to become effective approximately 18 months sooner than the standard adoption process.

### **ADOPTION**

The emergency graywater regulations, which added Chapter 16A "Nonpotable Water Reuse Systems" into the 2007 California Plumbing Code, were approved by the California Building Standards Commission (CBSC) on July 30, 2009. The emergency regulations were subsequently filed with the Secretary of State on August 4, 2009, effective immediately upon filing.

In compliance with the Administrative Procedure Act, HCD prepared a "Certificate of Compliance" confirming the completion of the rulemaking process, which included a 45-day public comment period, a subsequent 15-day comment period, a Final Statement of Reasons and the Final Express Terms.

The "Certificate of Compliance", along with the Final Express Terms, was unanimously approved by the CBSC and filed with the Secretary of State on January 27, 2010. With the rulemaking action complete, Title 24, Part 5, Chapter 16A, Part I emergency regulations of the 2007 California Plumbing Code were made permanent.

CERTIFICATE OF COMPLIANCE

DEPARTMENT OF HOUSING AND COMMUNITY DEVELOPMENT

The Department of Housing and Community Development (HCD) hereby certifies that it has, within 180 days of the effective date of the emergency building standards attached hereto, which were filed with the Secretary of State on August 4, 2009, given notice of the adoption thereof and afforded interested persons the opportunity to present statements, arguments, or contentions in a manner substantially similar to that provided by Government Code Sections 11346.2 – 11347.3.

  
Kim Strange, Deputy Director

12/21/09  
Date

**CHAPTER 16A**  
**NONPOTABLE WATER REUSE SYSTEMS**

**Part I**

**Intent**

*This part is applicable to occupancies under the authority of the Department of Housing and Community Development as specified in Section 108.2.1.1 and is intended to:*

- 1. Conserve water by facilitating greater reuse of laundry, shower, lavatory and similar sources of discharge for irrigation and/or indoor use.*
- 2. Reduce the number of non-compliant graywater systems by making legal compliance easily achievable.*
- 3. Provide guidance for avoiding potentially unhealthful conditions.*
- 4. Provide an alternative way to relieve stress on a private sewage disposal system by diverting the graywater.*

**1601A.0 Graywater Systems – General.**

**(A)** Except as otherwise provided for in this chapter, the provisions of this code shall be applicable to gray water installation. *The provisions of this part shall apply to the construction, alteration, discharge, use, and repair of graywater systems. The graywater system shall not be connected to any potable water system without an air gap or other physical device which prevents backflow and shall not cause the ponding or runoff of graywater. A city, county, or city and county or other local government may, after a public hearing and enactment of an ordinance or resolution, further restrict or prohibit the use of graywater systems. For additional information, see Health and Safety Code Section 18941.7.*

**(B)** *The type of system shall be determined by the location, discharge capacity, soil type, and ground water level. The system shall be designed to handle graywater discharged from the building and may include tank(s) and other appurtenances necessary to ensure proper function of the system.*

***Note:** It is not the intent of this section to require that all graywater must be handled by an irrigation field or disposal field. It is acceptable for excess graywater to be diverted to the building sewer through the overflow required pursuant to Section 1609A.0 (E).*

**(C)** No graywater system or part thereof shall be located on any lot other than the lot that is the site of the building or structure that discharges the graywater, nor shall any graywater system or part thereof be located at any point having less than the minimum distances indicated in Table 16A-1.

***Exception:** When there exists a lawfully recorded perpetual and exclusive covenant to an easement appurtenant and right-of-way between adjoining land-owners of two or more contiguous lots to discharge graywater from one lot to an adjoining lot.*

**(D)** No construction permit for any graywater system shall be issued until a plot plan with appropriate data satisfactory to the *Enforcing Agency* has been submitted and approved. When there is insufficient lot area or inappropriate soil conditions to *prevent the ponding or runoff* of the graywater, as determined by the *Enforcing Agency*, no graywater system shall be allowed.

***Exception:** A construction permit shall not be required for a clothes washer system which does not require cutting of the existing plumbing piping provided it is in compliance with Section 1603A.1.1.*

**(E)** *All graywater systems shall be designed to allow the user to direct the flow to either the irrigation or disposal field or the building sewer. The means of changing the direction of the graywater shall be clearly labeled and readily accessible to the user.*

**(F)** *Water used to wash diapers or similarly soiled or infectious garments or other prohibited contents shall be diverted by the user to the building sewer.*

**(G)** *Graywater shall not be used in spray irrigation, allowed to pond or runoff and shall not be discharged directly into or reach any storm sewer system or any surface body of water.*

- (H) Human contact with graywater or the soil irrigated by graywater shall be minimized and avoided, except as required to maintain the graywater system. The discharge point of any graywater irrigation or disposal field shall be covered by at least (2) inches (51 mm) of mulch, rock, or soil, or a solid shield to minimize the possibility of human contact.
- (I) Graywater shall not be used to irrigate root crops or edible parts of food crops that touch the soil.

#### **1602A.0 Definitions.**

**Clothes Washer System.** A graywater system utilizing only a single domestic clothes washing machine in a one- or two-family dwelling.

**Complex System.** Graywater systems that discharge over 250 gallons (947 L) per day.

**Disposal Field.** An intended destination for graywater including but not limited to a mulch basin or receiving landscape feature, graywater leach field, or other approved method of disposal.

**Graywater.** Pursuant to Health and Safety Code Section 17922.12, "graywater" means untreated wastewater that has not been contaminated by any toilet discharge, has not been affected by infectious, contaminated, or unhealthy bodily wastes, and does not present a threat from contamination by unhealthful processing, manufacturing, or operating wastes. "Graywater" includes but is not limited to wastewater from bathtubs, showers, bathroom washbasins, clothes washing machines, and laundry tubs, but does not include wastewater from kitchen sinks or dishwashers.

**Graywater System.** A system designed to collect graywater and transport it out of the structure for distribution in an Irrigation or Disposal Field. A graywater system may include tanks, valves, filters, pumps or other appurtenances along with piping and receiving landscape.

**Irrigation Field.** An intended destination for graywater in the receiving landscape including but not limited to a drip irrigation system, mulch basin, or other approved method of dispersal for irrigation purposes.

**Mulch.** Organic waste material including but not limited to leaves, prunings, straw, pulled weeds and wood chips. Mulch shall be permeable enough to allow rapid infiltration of graywater.

**Mulch Basin.** A type of irrigation or disposal field filled with mulch or other approved permeable material of sufficient depth, length and width to prevent ponding or runoff. A mulch basin may include a basin around a tree, a trough along a row of plants or other shapes necessary for irrigation or disposal.

**Receiving Landscape.** Includes features such as soil, basins, swales, mulch, and plants.

**Simple System.** A graywater system serving a one- or two-family dwelling with a discharge of 250 gallons (947 L) per day or less. Simple systems exceed a clothes washer system.

**Treated Graywater.** Nonpotable water collected and treated on-site suitable for direct beneficial use.

**1603A.0 Permit.**

A written construction permit shall be obtained from the Enforcing Agency prior to the erection, construction, reconstruction, installation, relocation or alteration of any graywater system that requires a permit.

**Exception:** A construction permit shall not be required for a clothes washer system which does not require cutting of the existing plumbing piping provided it is in compliance with Section 1603A.1.1.

**1603A.1 System Requirements.**

**1603A.1.1 Clothes Washer System.** A clothes washer system in compliance with all of the following is exempt from the construction permit specified in Section 108.4.1 and may be installed or altered without a construction permit:

1. If required, notification has been provided to the Enforcing Agency regarding the proposed location and installation of a graywater irrigation or disposal system.

**Note:** A city, county, or city and county or other local government may, after a public hearing and enactment of an ordinance or resolution, further restrict or prohibit the use of graywater systems. For additional information, see Health and Safety Code Section 18941.7.

2. The design shall allow the user to direct the flow to the irrigation or disposal field or the building sewer. The direction control of the graywater shall be clearly labeled and readily accessible to the user.
3. The installation, change, alteration or repair of the system does not include a potable water connection or a pump and does not affect other building, plumbing, electrical or mechanical components including structural features, egress, fire-life safety, sanitation, potable water supply piping or accessibility.  
**Note:** The pump in a clothes washer shall not be considered part of the graywater system.
4. The graywater shall be contained on the site where it is generated.
5. Graywater shall be directed to and contained within an irrigation or disposal field.
6. Ponding or runoff is prohibited and shall be considered a nuisance.
7. Graywater may be released above the ground surface provided at least two (2) inches (51 mm) of mulch, rock, or soil, or a solid shield covers the release point. Other methods which provide equivalent separation are also acceptable.
8. Graywater systems shall be designed to minimize contact with humans and domestic pets.
9. Water used to wash diapers or similarly soiled or infectious garments shall not be used and shall be diverted to the building sewer.
10. Graywater shall not contain hazardous chemicals derived from activities such as cleaning car parts, washing greasy or oily rags, or disposing of waste solutions from home photo labs or similar hobbyist or home occupational activities.
11. Exemption from construction permit requirements of this code shall not be deemed to grant authorization for any graywater system to be installed in a manner that violates other provisions of this code or any other laws or ordinances of the Enforcing Agency.
12. An operation and maintenance manual shall be provided. Directions shall indicate the manual is to remain with the building throughout the life of the system and indicate that upon change of ownership or occupancy, the new owner or tenant shall be notified the structure contains a graywater system.

**1603A.1.2 Simple System.** Simple systems exceed a clothes washer system and shall comply with the following:

1. The discharge capacity of a graywater system shall be determined by Section 1606A.0. Simple systems have a discharge capacity of 250 gallons (947 L) per day or less.
2. Simple systems shall require a construction permit, unless exempted from a construction permit by the Enforcing Agency. The Enforcing Agency shall consult with any public water system (as defined in Health and Safety Code, Section 116275) providing drinking water to the dwelling before allowing and exemption from a construction permit.
3. The design of simple systems shall be acceptable to the Enforcing Agency and shall meet generally accepted graywater system design criteria.

**1603A.1.3 Complex System.** Any graywater system that is not a clothes washer system or simple system shall comply with the following:

1. The discharge capacity of a graywater system shall be determined by Section 1606A.0. Complex systems have a discharge capacity over 250 gallons (947 L) per day.
2. Complex systems shall require a construction permit, unless exempted from a construction permit by the Enforcing Agency. The Enforcing Agency shall consult with any public water system (as defined in Health and Safety Code, Section 116275) providing drinking water to the dwelling before allowing and exemption from a construction permit.
3. A complex system shall be designed by a person who can demonstrate competence to the satisfaction of the Enforcing Agency.

**Table 1603A.1.4 – Construction Permit Requirements**

<b>Type of System</b>	<b>Permit Requirements</b>
Clothes Washer System	No construction permit required if conditions in Section 1603A.1.1 are met.
Simple System	Permit and plans required unless exempted by Enforcing Agency.
Complex System	Permit and plans required unless exempted by Enforcing Agency.
Treated Graywater	Permit and plans required unless exempted by Enforcing Agency.

**1604A.0 Drawings and Specifications.**

Graywater systems for which a construction permit is required may be subject to submittal of plans and details of the proposed graywater system necessary to ensure compliance with the requirements of this chapter. Identification of the groundwater level and soil absorption qualities at the site shall be included in the plans or provided to the Enforcing Agency.

**Exception:** The Enforcing Agency may waive the requirement for identification of groundwater level and/or soil absorption qualities based on knowledge of local conditions.

**1604A.1 Groundwater Depth.** Verification of ground water levels which exceed three (3) vertical feet (915 mm) from the deepest irrigation or disposal point of the proposed graywater system shall not be required.

**Note:** The absence of groundwater in a test hole three (3) vertical feet (915 mm) below the deepest irrigation or disposal point shall be sufficient to satisfy this section unless seasonal high groundwater levels have been documented to rise to within this area.

**1605A.0 Inspection and Testing.**

**(A) Inspection.** A graywater system for which a construction permit is required shall be subject to inspection by the Enforcing Agency and such construction or work shall remain accessible and exposed for inspection purposes until approved.

At the time of final inspection, an operation and maintenance manual shall be provided. Directions shall indicate the manual is to remain with the building throughout the life of the system and upon change of ownership, the new owner shall be notified the structure contains a graywater system

**(B) Testing.**

- (1) Tanks shall be filled with water to the overflow line prior to and during inspection. Seams and joints shall be left exposed, and the tank shall remain watertight.
- (2) A flow test shall be performed through the system to the point of graywater irrigation or disposal. Lines and components shall be watertight.

**1606A.0 Procedure for Estimating Graywater Discharge.**

**(A) Single Family Dwellings and Multi-Family Dwellings.** The graywater discharge for single family and multi-family dwellings shall be calculated by estimates of graywater use based on water use records, calculations of local daily per person interior water use, or the following procedure:

1. The number of occupants of each dwelling unit shall be calculated as follows:

First Bedroom	2 occupants
Each additional bedroom	1 occupant

2. The estimated graywater flows of each occupant shall be calculated as follows:

Showers, bathtubs and wash basins	25 GPD (95 LPD)/occupant
Laundry	15 GPD (57 LPD)/occupant

3. The total number of occupants shall be multiplied by the applicable estimated graywater discharge as provided above and the type of fixtures connected to the graywater system.

**(B) Daily Discharge –** Graywater systems using tanks shall be designed to minimize the amount of time graywater is held in the tank and shall be sized to distribute the total amount of estimated graywater on a daily basis.

**Exception:** Treated graywater systems when approved by the Enforcing Agency.

**1607A.0 Required Area of Irrigation or Disposal Fields.** Irrigation or disposal fields may have one or more valved zones. Each zone must be of adequate size to receive the graywater anticipated in that zone. No irrigation or disposal field shall extend within three (3) vertical feet (915 mm) of the highest known seasonal groundwater, or to a depth where graywater contaminates the groundwater, ocean water or surface water. The applicant shall supply evidence of groundwater depth to the satisfaction of the Enforcing Agency.

**Note:** The absence of groundwater in a test hole three (3) vertical feet (915 mm) below the deepest irrigation or disposal point shall be sufficient to satisfy this section unless seasonal high groundwater levels have been documented to rise to within this area.

**1608A.0 Determination of Maximum Absorption Capacity.**

(A) Wherever practicable, *irrigation or disposal* field size shall be computed from Table 16A-2.

(B) In order to determine the absorption quantities of questionable soils other than those listed in Table 16A-2, the proposed site may be subjected to percolation tests acceptable to the *Enforcing Agency*.

*Exception: Irrigation fields in compliance with Section 1611A.2, which only utilize drip type emitters.*

(C) When a percolation test is required, no graywater system shall be permitted if the test shows the absorption capacity of the soil is *unable to accommodate the intended discharge of the proposed graywater system*.

*Exception: The Enforcing Agency may waive the requirement for percolation tests based on knowledge of local conditions or accept other testing methods.*

**1609A.0 Tank Construction.**

(A) *When system design includes a tank, specifications for the tank shall be submitted to the Enforcing Agency for approval.* Such plans shall show all dimensions and other pertinent data.

(B) Tanks shall be constructed of solid, durable materials not subject to excessive corrosion or decay and shall be water-tight.

(C) Each tank shall be vented as required by Chapter 9 of this code, shall *be sealed against vermin and mosquitoes, and have an access opening to allow for inspection and cleaning.*

(D) Each tank shall have its rated capacity permanently marked on the unit. In addition, a sign stating "GRAYWATER IRRIGATION SYSTEM, CAUTION — UNSAFE WATER" shall be permanently marked on the holding tank.

(E) Each tank shall have an *overflow drain*. The overflow drain shall have a permanent connection to the building drain or building sewer, upstream of septic tanks, if any. The overflow drain shall not be equipped with a shutoff valve.

(F) The *overflow drain* shall not be less in size than the inlet pipe. The vent size shall be determined based on the total graywater fixture units as outlined in Table 7-5 of this code. Unions or equally effective fittings shall be provided for all piping connected to the holding tank.

(G) Each tank shall be structurally designed to withstand all anticipated earth or other loads. *Tank covers* shall be capable of supporting an earth load of not less than three hundred (300) pounds per square foot (1,464.7 kg/m<sup>2</sup>) when the tank is *used* for underground installation.

(H) *The overflow system* must be designed so that the tank overflow will gravity drain to the existing sewer line or septic tank. The tank shall be protected against sewer line backflow by a backwater valve.

(I) *An overflow drain and backwater valve is not required on a clothes washer system.*

**1610A.0 Graywater Systems.**

Graywater systems shall comply with Sections 1610A.1 through 1610A.3.

**1610A.1 Pipe Materials.** Graywater pipe, valves and fittings shall conform to the requirements of Sections 604.0, 605.0 and 606.0.

**1610A.2 Identification.** *Graywater distribution piping upstream of any connection to an irrigation or disposal field or a distribution valve shall be identified with the words "CAUTION: NONPOTABLE WATER, DO NOT DRINK." Marking shall be at intervals not to exceed five (5) feet (1,524 mm).*

**1610A.3 Valves.** All valves shall be accessible. A backwater valve installed pursuant to this code shall be provided on all tank drain connections to the sanitary drain or sewer piping.



**1611A.0 Irrigation, Disposal Field and Mulch Basin Construction.**

*Irrigation fields, disposal fields and mulch basins used in graywater systems shall comply with this section. Graywater systems may contain either a irrigation field or a disposal field or a combination of both. This section is not intended to prevent the use of other methods of graywater irrigation or disposal approved by the Enforcing Agency.*

**1611A.1 Mulch Basin** *A mulch basin may be used as an irrigation or disposal field. Mulch basins shall be sized in accordance with Table 16A-2 and of sufficient depth, length and width to prevent ponding or runoff during the graywater surge of a clothes washer, bathtub or shower. Mulch must be replenished as required due to decomposition of organic matter. Mulch basins will require periodic maintenance, reshaping or removal of dirt to maintain surge capacity and to accommodate plant growth and prevent ponding or runoff,*

**1611A.2 Irrigation Field.** *The provisions of this section are not intended to prevent the use of any appropriate material, appliance, installation, device, design or method of construction. If an alternate design is not available, the following provisions may be used as guidance in the design of a graywater irrigation field:*

- (1) Filters used in graywater irrigation systems shall be as specified by the manufacturer's installation instructions for the design flow rate and intended use. The filter backwash and flush discharge shall be contained and disposed of into the building sewer system, septic tank or, with approval of the Enforcing Agency, a separate mini-leachfield sized to accept all the backwash and flush discharge water. Filter backwash water and flush water shall not be used for any purpose. Sanitary procedures shall be followed when handling filter backwash and flush discharge or graywater.*
- (2) Emitters shall be designed to resist root intrusion and shall be of a design recommended by the manufacturer for the intended graywater flow and use. For emitter ratings, refer to Irrigation Equipment Performance Report, Drip Emitters and Micro-Sprinklers, Center for Irrigation Technology, California State University, 5730 N. Chestnut Avenue, Fresno, California 93740-0018.*
- (3) Each irrigation zone shall be designed to include no less than the number of emitters specified in Table 16A-3, or through a procedure designated by the Enforcing Agency. Minimum spacing between emitters in any direction shall be sufficient to prevent surfacing or runoff.*
- (4) The system design shall provide user controls, such as valves, switches, timers and other controllers, as appropriate, to rotate the distribution of graywater between irrigation zones.*
- (5) All drip irrigation supply lines shall be polyethylene tubing or PVC Class 200 pipe or better and Schedule 40 fittings. All joints shall be properly solvent-cemented, inspected and pressure tested at 40 psi (276 kPa), and shown to be drip tight for five minutes, before burial. All supply piping shall be covered to a minimum depth of two (2) inches (51 mm) of mulch or soil. Drip feeder lines can be poly or flexible PVC tubing and shall be covered to a minimum depth of two (2) inches (51 mm) of mulch or soil.*
- (6) Where pressure at the discharge side of the pump exceeds 20 psi (138 kPa), a pressure-reducing valve able to maintain downstream pressure no greater than 20 psi (138 kPa) shall be installed downstream from the pump and before any emission device.*
- (7) Each irrigation zone shall include a flush valve/antisiphon valve to prevent back siphonage of water and soil.*

**1611A.3 Disposal Field.** *The provisions of this section are not intended to prevent the use of any appropriate material, appliance, installation, device, design or method of construction. If an alternate design is not available the following provisions may be used as guidance in the design of a graywater disposal field:*

- (A)** *Disposal systems shall be not less than three (3) inches (80 mm) in cross sectional dimension and shall be constructed of perforated high-density polyethylene pipe, perforated ABS pipe, perforated PVC pipe, leaching chambers or other approved materials, provided that sufficient openings are available for distribution of the graywater into the trench area. Material, construction, and perforation shall be in compliance with the appropriate absorption fields drainage standards and shall be approved by the Enforcing Agency.*

- (B) Filter material, clean stone, gravel, slag, or similar filter material acceptable to the *Enforcing Agency*, varying in size from three-quarter (3/4) inch (19.1 mm) to two and one-half (2-1/2) inches (64 mm) shall be placed in the trench to the depth and grade required by this section. The perforated section shall be laid on the filter material in an approved manner. The perforated section shall then be covered with filter material to the minimum depth required by this section. The filter material shall then be covered with untreated building paper, straw, or similar porous material to prevent closure of voids with earth backfill. No earth backfill shall be placed over the filter material cover until after inspection and acceptance.

**Exception.** *Manufactured leaching chambers shall be installed in compliance with the manufacturer's installation instructions.*

- (C) *Disposal* fields shall be constructed as follows:

(See chart below)

	Minimum	Maximum
Number of drain lines per valved zone <sup>†</sup>	1	—
Length of each perforated line <sup>†</sup>	—	100 ft. (30,840 mm)
Bottom width of trench <sup>†</sup>	12 in. (305 mm)	24 in. (610 mm)
Spacing of lines, center to center <sup>†</sup>	4 ft. (1219 mm)	—
Depth of earth cover of lines	2 in. (51 mm)	—
Depth of filter material cover of lines	2 in. (51 mm)	—
Depth of filter material beneath lines <sup>†</sup>	3 in. (76 mm)	—
Grade of perforated lines	level	3 in./100 ft. (2 mm/m)

<sup>†</sup>*Manufactured leaching chambers shall be installed in compliance with the manufacturer's installation instructions.*

- (D) When necessary on sloping ground to prevent excessive line slopes, disposal lines shall be stepped or installed on the contour lines of the slope. The lines between each horizontal leaching section shall be made with approved water-tight joints and installed on natural or unfilled ground.

#### 1612A.0 Special Provisions

- (A) Other collection and distribution systems shall be permitted by the local *Enforcing Agency*, as allowed by Section 108.7 of this code.
- (B) Nothing contained in this chapter shall be construed to prevent a city, county, or city and county or other local government from, after a public hearing and enactment of an ordinance or resolution, further restricting or prohibiting the use of graywater systems. For additional information, see Health and Safety Code Section 18941.7.
- (C) Graywater stub-out plumbing may be allowed for future connection prior to the installation of irrigation lines and landscaping. Stub-out shall be permanently marked "GRAYWATER STUB-OUT, CAUTION --- UNSAFE WATER".

**Table 16A -1 Location of Graywater System**

<b>Minimum Horizontal Distance Required From:</b>	<b>Tank</b>	<b>Irrigation Field</b>	<b>Disposal Field</b>
	<b>Feet/mm</b>	<b>Feet/mm</b>	<b>Feet/mm</b>
Building structures <sup>1</sup>	5 (1,524 mm) <sup>2</sup>	2 (610 mm)	5 (1,524 mm)
Property line adjoining private property	5 (1,524 mm)	1.5 feet (458 mm)	5 (1,524 mm)
Water supply wells <sup>3</sup>	50 (15,240 mm)	100 (30,480 mm)	100 (30,480 mm)
Streams and lakes <sup>3</sup>	50 (15,240 mm)	100 (30,480 mm) <sup>4,5</sup>	100 (30,480 mm) <sup>4</sup>
Sewage pits or cesspools	5 (1,524 mm)	5 (1,524 mm)	5 (1,524 mm)
Sewage disposal field	5 (1,524 mm)	4 (1,219 mm) <sup>6</sup>	4 (1,219 mm) <sup>6</sup>
Septic tank	0 (0)	5 (1,524 mm)	5 (1,524 mm)
Onsite domestic water service line	5 (1,524 mm)	0 (0 mm)	0 (0 mm)
Pressurized public water main	10 (3,048 mm)	10 (3,048 mm) <sup>7</sup>	10 (3,048 mm) <sup>7</sup>

<sup>1</sup> Building structures does not include porches and steps, whether covered or uncovered, breezeways, roofed porte cocheres, roofed patios, carports, covered walks, covered driveways, and similar structures or appurtenances.  
<sup>2</sup> Underground tanks shall not be located within a 45 degree angle from the bottom of the foundation, or they shall be designed to address the surcharge imposed by the structure. The distance may be reduced to six (6) inches (153 mm) for aboveground tanks when first approved by the Enforcing Agency.  
<sup>3</sup> Where special hazards are involved, the distance required shall be increased as directed by the Enforcing Agency.  
<sup>4</sup> These minimum clear horizontal distances shall also apply between the irrigation or disposal field and the ocean mean higher high tide line.  
<sup>5</sup> The minimum horizontal distance may be reduced to 50 feet (15,240 mm) for irrigation fields utilizing graywater which has been filtered prior to entering the distribution piping.  
<sup>6</sup> Plus two (2) feet (610 mm) for each additional foot of depth in excess of one (1) foot (305 mm) below the bottom of the drain line.  
<sup>7</sup> For parallel construction or crossings, approval by the Enforcing Agency shall be required.

**Table 16A-2 Design Criteria of Six Typical Soils**

<b>Type of Soil</b>	<b>Square Feet</b>	<b>Gallons</b>	<b>Square Meters</b>	<b>Liters</b>
	<b>Minimum square feet of irrigation/leaching area per 100 gallons of estimated graywater discharge per day</b>	<b>Maximum absorption capacity in gallons per square foot of irrigation/leaching area for a 24-hour period</b>	<b>Minimum square meters of irrigation/leaching area per liter of estimated graywater discharge per day</b>	<b>Maximum absorption capacity in liters per square meter of irrigation/leaching area for a 24-hour period</b>
Coarse sand or gravel	20	5.0	0.005	203.7
Fine sand	25	4.0	0.006	162.9
Sandy loam	40	2.5	0.010	101.8
Sandy clay	60	1.7	0.015	69.2
Clay with considerable sand or gravel	90	1.1	0.022	44.8
Clay with small amounts of sand or gravel	120	0.8	0.030	32.6

**Table 16A-3 Subsurface Drip Design Criteria of Six Typical Soils**

<b>Type of Soil</b>	<b>Maximum emitter discharge (gal/day)</b>	<b>Minimum number of emitters per gpd of graywater production</b>
1.Sand	1.8	0.6
2.Sandy loam	1.4	0.7
3.Loam	1.2	0.9
4.Clay loam	0.9	1.1
5.Silty clay	0.6	1.6
6.Clay	0.5	2.0

Use the daily graywater flow calculated in Section 1606A.0 to determine the number of emitters per line.

**1612A.1 Indoor Use of Treated Graywater.**

Graywater shall not be allowed for indoor use, such as flushing toilets and urinals, unless treated by an on-site water treatment system approved by the Enforcing Agency. For the purposes of this section, graywater treated by an on-site water treatment system shall be considered "Treated Graywater". Treated graywater and treated graywater systems shall comply with the provisions of this code except as otherwise provided in this chapter and all of the following:

- (1) The treated graywater shall have a separate tank sized to minimize the length of time it is retained.
- (2) A maintenance and operation manual for the treatment system shall be kept at the location of the system.
- (3) Treated graywater intended for use indoors shall meet the California Department of Public Health statewide uniform criteria for disinfected tertiary recycled water as provided in California Code of Regulations, Title 22 Section 60301.230.
- (4) The treated graywater system shall be installed, inspected and tested as specified for reclaimed water systems in Sections 1618.0 and 1620.0.

**NOTE:**

Authority Cited: Health and Safety Code Sections 17040, 17921, 17922 and 19990.

Reference: Health and Safety Code Sections 17922.12 and 18941.7.

# SAN LUIS OBISPO GUIDE TO THE USE OF

# GRAYWATER



Vegetated leach field, page 15.



Constructed wetland reed beds, page 21-22.



SLO Botanic Garden building uses a constructed wetland water reclamation system creating riparian habitat page, 21-22.

**\$10**

This is the first of an educational series regarding water and waste applications of appropriate technology for San Luis Obispo County. **Appropriate technology** is defined as:

Applying technology to address problems related to energy use, the water cycle, and affordable building at the smallest and most accessible scale possible.

These guidelines are being developed by the San Luis Obispo Coalition of Appropriate Technology (SLO-COAT) to specifically address efforts to maintain a healthy hydrologic cycle in San Luis Obispo County.

**SLO-COAT** is a joint effort by SLO Green Build, the San Luis Bay Chapter of the Surfrider Foundation and the Santa Lucia Chapter of the Sierra Club. The information presented is for general education purposes. Final details and construction must be developed and designed for specific site conditions; therefore, SLO-COAT is hereby indemnified from any liability arising from the use of this information.



Cover images (clockwise from top left) courtesy of Carmichael Environmental Design/Build, Greg McMillan and San Luis Sustainability Group Architects.

## **HISTORY**

During Jerry Brown's Administration in California from 1972 to 1980, the State Office of Appropriate Technology was developed. OAT as it was called was headed by Sim Van der Ryn, the State Architect at the time. OAT encouraged the application of appropriate technologies to address the economic and environmental concerns of development.

## **SITUATION**

The dismantling of OAT by the next administration in 1980 proved to be short-sighted given the ongoing concerns about energy and the double threat of climate change coupled with peak fossil fuel supply. The water imbalances in San Luis Obispo County have become evident as many municipalities implement water rationing policies. Growth has always been naturally restrained due to scarce water resources in the County, so increased infrastructure costs burden new development. Fortunately, over the past thirty years, the research and refinement of appropriate technologies have much to offer us today.

**SLO-COAT** believes it is imperative that we revisit, at a local scale, the encouragement and application of appropriate technology. San Luis Obispo County is in a position to be at the forefront of these efforts to reconcile growth and environmental quality. This San Luis Obispo Guide to the Use of Graywater was produced to encourage the use of graywater in a safe and legal manner.

*Contributing members of SLO-COAT: Ken Haggard-Architect & Planner, Mikel Robertson- General Contractor & Green Building Material Specialist, Rachel Aljilani- LEED AP, Joshua Carmichael- Landscape Designer & Contractor*

### *Special thanks to:*

*Brad Lancaster, Art Ludwig, Brock Dolman and Johnathan Todd who have helped educate our community on the current trends in appropriate technology applications and regulations. Of course this would not be possible without the support of SLO-COAT members: Mladen Bandov, Andrew Christie, Mary Fullwood, Cheryl Lenhardt, Steve Paige, Scott Peterson, Lawson Schaller, Jessica Steely, Karen Venditti, Sam Studer, and the numerous family and friends who are also concerned about water resources and sustainable development.*

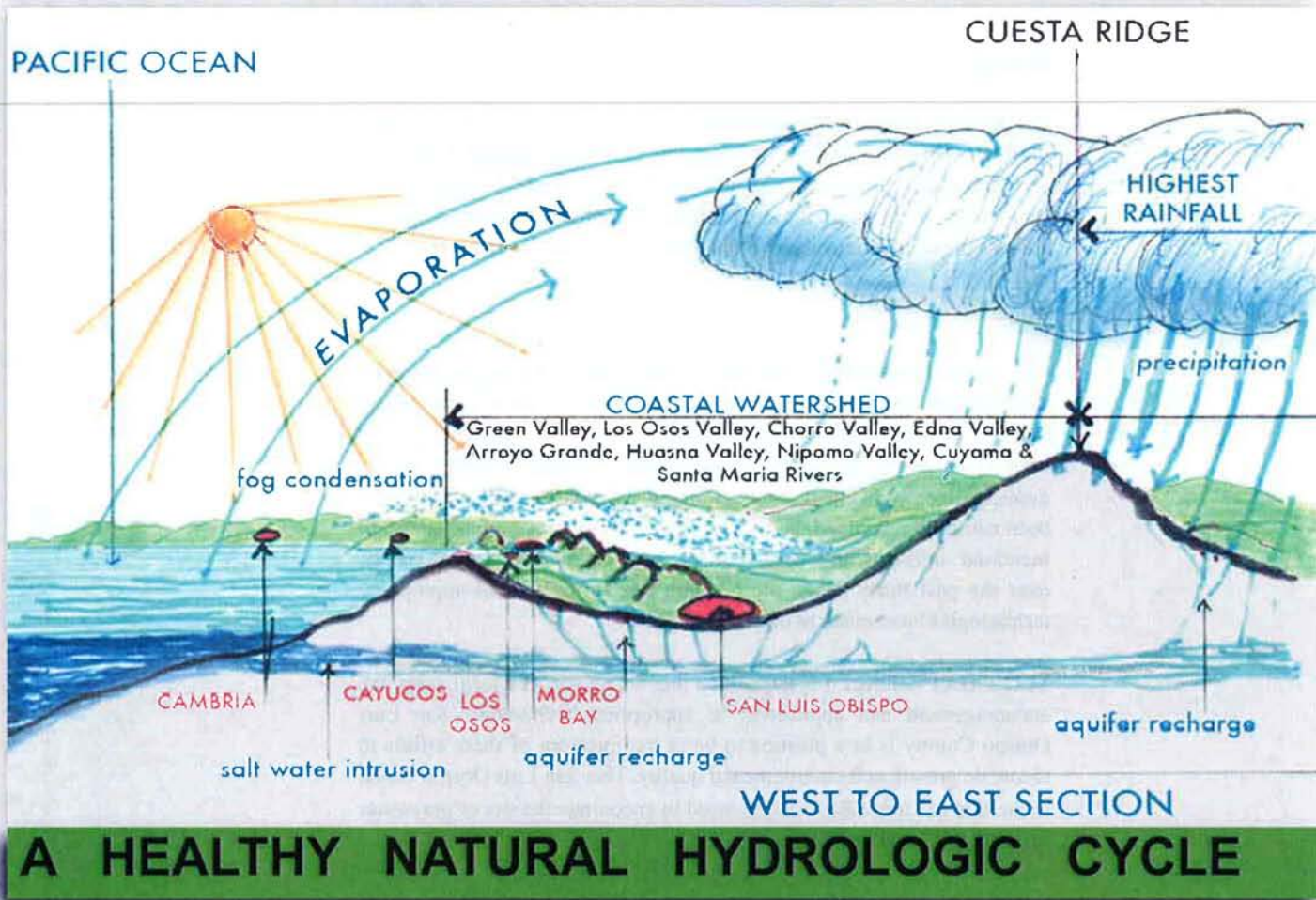

*The Greening of San Luis Obispo sketch by Ken Haggard*

**APPROPRIATE TECHNOLOGY SUPPORTS**



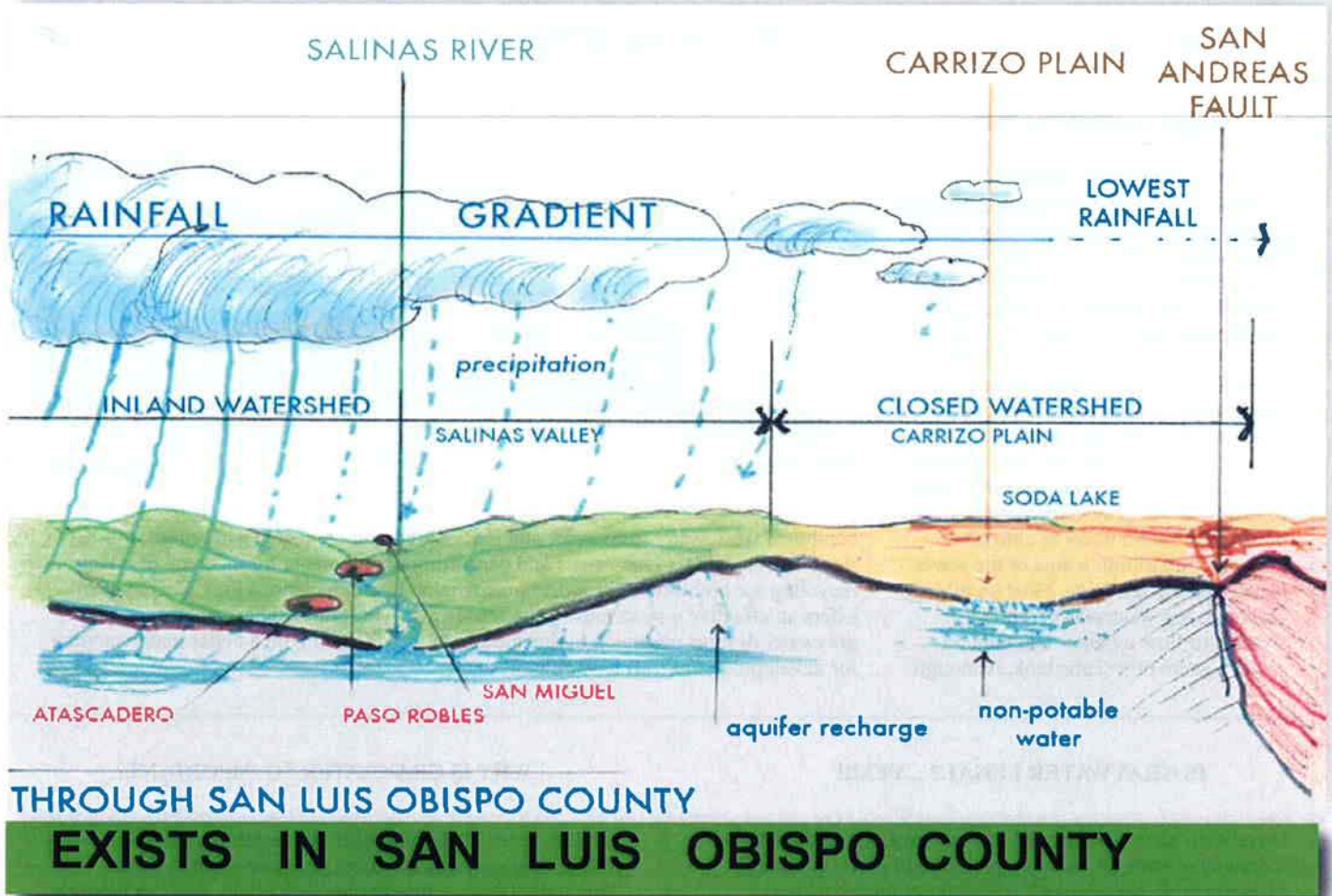

A healthy hydrologic cycle provides fresh water in the form of precipitation and condensation. This water is transmitted to riparian systems consisting of rivers and streams which in turn charge underground aquifers. In its natural state, this cycle creates healthy watersheds, prevents erosion, stabilizes salt water intrusion and supports rich ecological systems.

Increased built areas usually accentuate adverse changes to the natural hydrologic cycle; therefore, it becomes of vital necessity for us to mimic the natural hydrologic cycle, using the same processes regarding water movement, filtration, and storage.

Application of appropriate technologies as described in this guide can allow development while still maintaining a healthy hydrologic cycle. In addition to graywater, appropriate technology topics related to a healthy water ecology are:

- Low Impact Development**
- Rainwater Harvesting**
- Waterless Waste Treatment**
- Bioremediation Strategies**

Look forward to more information and educational events presented by SLO-COAT on these topics. If you would like to become involved contact SLO Green Build through the web at [www.slogreenbuild.org](http://www.slogreenbuild.org)

## GROWTH & A HEALTHY HYDROLOGIC CYCLE

# INTRODUCTION

## WHAT IS GRAYWATER ?

Graywater is untreated household or building waste water that has not come in contact with toilet or kitchen sink waste. Essentially, graywater is soapy water from washing machines, bathroom sinks, bathtubs, and showers. Graywater should not be stored as it will quickly become foul and turn into blackwater unless treated. Graywater is kept separate from blackwater, which comes from kitchen sinks, dishwashers and toilets. Blackwater is not safe for reuse without more elaborate procedures for treatment & filtration. All graywater systems must be valved to send water to either the graywater distribution area or the sewer/septic (blackwater) line. Most plumbing combines the wastewater from all fixtures to flow together into either a sewer system or a septic tank. Although



combined wastewater (graywater and blackwater) can be treated and reused, the rigorous standards, system costs and permitting requirements for this type of water recycling are prohibitive for most homeowners. In comparison, a graywater system offers an effective way to reuse your wastewater with minimal cost and effort. The graywater designs presented in this guide can provide you with a better understanding for developing your own graywater system.

## IS GRAYWATER LEGAL? ...YES!!!

There is an increased demand for water due to population and economic growth. In addition, pollution of and reduction in the water table has adversely affected our once balanced ecosystems, making water an increasingly important and valuable natural resource. Clean potable water is the most valuable type of water, but graywater is useful in meeting our water needs as well. Graywater should not be considered a waste product because it is a valuable resource that can be

## WHY IS GRAYWATER SO IMPORTANT?

applied to irrigation and other non-potable water uses. Harvesting graywater to meet your non-potable water demand utilizes an appropriate technology that can recover initial costs quickly. The added benefits to your watershed and community infrastructure make having a graywater system an environmentally friendly solution to scarce water supplies, since more than half of your indoor water can be reused as graywater. It's time to tap into graywater!

## POSITIVE IMPACTS OF GRAYWATER SYSTEMS

1. Lower water utility bills for home or business occupants
2. Potential for landscape irrigation
3. Groundwater or aquifer recharge
4. Reduced strain on septic or sewer systems which in turn lower energy loads at central treatment plants
5. Bioremediation strategies can clean water and enhance the local ecology
6. Feel good about conserving a precious resource essential to our lives
7. Preserve potable water sources for future uses

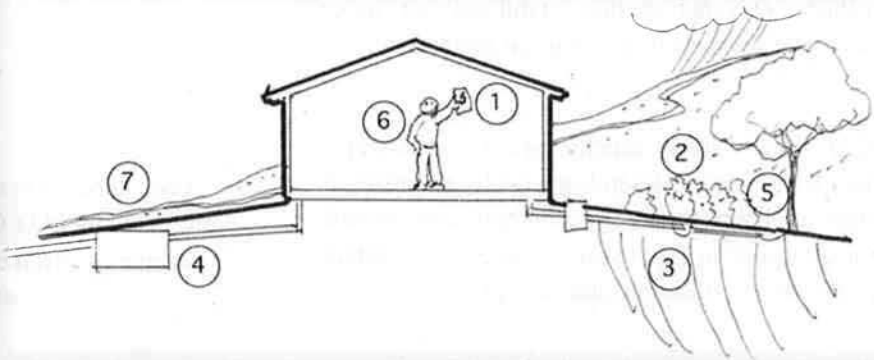

# I N D E X

	<u>page #</u>
Introduction.....	3-4
How to Get Started.....	5-6
Calculations & Standards.....	7-8
Graywater Process & Design Options .....	9-10
 <b>CARD: RECIPE CARDS FOR OPTIONS SHOWN ON PAGE 8</b>	
<b>A</b> <u>Surge Tank Options</u> .....	11
<b>B</b> <u>Distribution Options</u> .....	11
<b>C</b> <u>Branched System</u> .....	12
<b>D</b> <u>Flower Pot Emitter</u> .....	13
<b>E</b> <u>Mini- Leach Field</u> .....	14
<b>F</b> <u>Vegetated Leach Field</u> .....	15
<b>G</b> <u>Mulched Watering Moat</u> .....	16
<b>H</b> <u>Tree Watering Moat</u> .....	17
<b>I</b> <u>Infiltration Galley</u> .....	18
<b>J</b> <u>Drip System with Rewatering</u> .....	19-20
<b>K</b> <u>Reed Beds</u> .....	21-22
<b>L</b> <u>Washing Machine Sump</u> .....	23
<b>M</b> <u>In House Use of Graywater</u> .....	24
Checklist .....	25
Summary & References.....	26
Appendix 1 - Detergents for Graywater Systems.....	27
Appendix 2 - Plants for Graywater Systems.....	28
Glossary of Graywater Terms .....	29-31

This guide has been set-up in a way that allows you to consider options that are appropriate for your specific site conditions and graywater resources, pages 7-10.

Once you choose a graywater system that is right for you, then you can use the recipe cards to determine the components and overall design.

## 10 Easy Steps to Develop Your Own Graywater System

### Reference page

- 1 Adopt a baseline conservation program. \_\_\_\_\_ 7
- 2 Do a few calculations to determine:
  - a. Graywater flow. \_\_\_\_\_ 7
  - b. Soil absorption capacity & distribution area. \_\_\_\_\_ 8
  - c. Site planning issues. \_\_\_\_\_ 8
- 3 Evaluate system options to determine the solution for your situation. \_\_\_\_\_ 10
- 4 Draw up your chosen system using page 8 and the recipe cards. \_\_\_\_\_ 11-24
- 5 Use the checklist provided to refine your design. \_\_\_\_\_ 25
- 6 Provide and keep an operations and maintenance manual for your system. This manual shall remain with the building throughout the life of the system and upon change of ownership, the new owner shall be notified the structure contains a graywater system. [Ref. 9]
- 7 Apply and obtain a permit from the County or your City (if necessary).
- 8 Construct your system.
- 9 Operate & maintain your system.
- 10 Enjoy your graywater use and educate others about the process and benefits.

You can use graywater, it is legal under state regulations. This guide illustrates how to design, permit and maintain your own graywater system as interpreted by the California State Graywater law [ref. 4].

**Maintaining and Using Graywater**

- Graywater should be avoided when irrigating edibles in your landscape. [Ref. 9]
- Avoid planting invasive water loving plants (pampas grass, Arunda donax, scotch broom, etc.).
- Avoid using graywater in hoses that can be used to wash or play with.
- Potable and graywater supply pipes should never be connected.
- Graywater that has come in contact with soiled diapers is blackwater.
- Corrugated pipes for graywater discharge should be avoided, they slow the flow.
- Use a subsurface drip system when irrigating lawns.
- In general, tilling organic matter into soil that comes in contact with graywater is good.

**Detergents & Cleaners [ref. 1]**

Additional information regarding the composition of detergents can be found in appendix 1- Detergents for Graywater Systems, page 27.

Hand soaps and shampoos by and large do not damage plants or clog soil profiles, in fact graywater is a light fertilizer. Laundry detergents commonly have sodium and boron which are chemicals that can have a negative effect on landscapes. The following are detergents or cleaners to avoid:

- Bleaches or softeners
- Detergents that advertise whitening, softening, and enzymatic powers
- Detergents with the following ingredients: boron, borax, chlorine, bleach, petroleum distillers, sodium and peroxygen
- Products designed to open clogs without scrubbing
- Water softeners that use sodium chloride

**Plants that Typically Love Graywater [ref. 1]**

Oleander, bougainvillea, fan and date palms, rosemary, roses, agapanthus, Bermuda grass, honeysuckle, Australian tea tree, Italian stone, oaks, Arizona cypress, cottonwood, olive, ice plant, juniper, purple hopseed, manzanita, ceanothus, rushes, coffeeberry, toyon, western redbud, california wax myrtel, penstemon.

**Plants that Typically Don't Like Graywater [ref. 1]**

Rhododendron, bleeding hearts, wood sorrel, hydrangeas, azaleas, violets, impatiens, begonias, ferns, foxgloves, gardenias, philodendron, camellias, primroses, crape mertyle, redwoods, star jasmine, holly and deoder cedar.

For more information on graywater plants, see appendix 2- Plants for Graywater Systems, page 28.

# CONSERVATION FIRST, THEN

## STEP 1: BASELINE CONSERVATION

### Bathrooms

- Check for leaks from pipes and faucets, the smallest drip can waste up to 2 gallons per day!
- Install dual-flush or ultra low flow toilets.
- Install low-flow faucets or faucet aerators.
- Turn off water while brushing your teeth and shaving.
- Take 5 minute or shorter showers and turn water off during and while soaping.

### Kitchen

- Scrape rather than rinse dishes before placing them in the dishwasher.
- Do not thaw frozen food under running water.
- When hand washing dishes, fill one basin with soapy water and the other with rinse water.
- Install Energy Star rated dishwasher and only wash full loads.
- Avoid running water continuously while washing dishes.

### Laundry

- Install Energy Star clothes washer and set water volume to the minimum requirement per load.
- Use short water cycles for lightly soiled loads.
- Pre-treat stains to avoid multiple washings.
- Soak heavily soiled items in a sink one third full to prewash.

Before incorporating graywater into your lifestyle, first start off by adopting a baseline conservation plan. Conservation is the most affordable technology and practices are readily available that require little if any behavior change. Most water providers have programs to help you conserve that offer free or discounted low flow shower heads, faucet aerators, toilet tumblers and more.

While this document does not attempt to provide a thorough cost benefit analysis, we recognize it is a worthwhile consideration. Cost/benefit will vary greatly depending on the graywater system selected, the local cost of water and the volumes utilized. Some systems are very simple, low cost and can be done by the homeowner with few new parts and supplies, or by integrating salvaged/used materials. Other systems are more complex, requiring professional installation, and expensive components. Regardless of the system selected and the volumes utilized, the user will have the satisfaction and benefit of reusing water, helping the environment, and having a drought resistant supply during mandatory watering restrictions.

## STEP 2: CALCULATIONS A- Graywater Flow

Using the number of bedrooms in your residence provides an estimate of the graywater flow for typical households:

Enter the number of bedrooms =

Calculate the number of occupants =   
 • Start with two (2) occupants for the first bedroom  
 • Add one (1) occupant for each additional bedroom

Graywater can be estimated as generated from each occupant on a daily basis. Choose from the following list of sources based on your graywater system. Each graywater flow estimate is based per occupant.

Showers, bathtubs, wash basins & clothes washer	40 gallons per day
Showers, bathtubs & wash basins (only)	25 gallons per day
Clothes washer (only)	15 gallons per day

Multiply the number of occupants by the estimated graywater flow in gallons per day (gpd) per occupant to determine the total estimated graywater flow.

Number of occupants	x	Graywater flow per occupant	=	Total estimated graywater flow
<input style="width: 50px;" type="text"/>	x	<input style="width: 50px;" type="text"/> gpd	=	<input style="width: 50px;" type="text"/> gpd

For example, the graywater flow for a four-bedroom main house, which includes all fixtures such as showers, sinks, and clothes washer, and a one-bedroom guest house, which includes only a shower and sink, is estimated :

Main House (4 bedroom):	5 occupants	x	40 gpd per occupant	=	200 gpd
Guest House (1 bedroom):	2 occupants	x	25 gpd per occupant	=	50 gpd
<b>TOTAL GRAYWATER</b>					<b>= 250 gpd</b>

# CALCULATIONS & STANDARDS

## STEP 2: CALCULATIONS B - Soil Absorption Capacity & Distribution Area

Design the graywater system based on the soil and groundwater conditions of the property. Select an area within the property boundaries to be used for irrigation or disposal of the graywater. The surface and subsurface soil must be suitable to accept the design flow of graywater. The fundamental soil characteristic is the percolation rate, which indicates how fast the soil can absorb water. Soil types like fine sand or sandy loam have better percolation rates than clay, for instance. Better percolation rates mean that less area will be required to adequately disperse all the graywater.

### Percolation Test Procedures

Select percolation test locations in the area to be used for graywater disposal. Dig a few test holes (8"-12" diameter) to the same depth as the bottom of the hole disposal area. Cover the hole bottom with 2" of gravel. Pre-soak holes overnight. During the test, fill the holes at least 8"-10" above the gravel. Using a stake marked at 1/4" intervals, measure the falling water level at 30 minute intervals while refilling after each measurement. Obtain at least 12 measurements (i.e., a perc test is at least 6 hours long.) The drop during the final 30-minute interval is the calculated percolation rate converted to minutes per inch. For sandy soils where the water level drops faster than 6" in 25 minutes, take 12 measurements every 10 minutes.

**Percolation Rate Table:**

Soil Type	Percolation Test Results (min/inch)	Infiltration Type Irrigation (sf/gpd)	18" Wide Mini-Leachfield (linear ft/gpd)	Subsurface Drip System (sf/gpd)
	0 - 4	not allowed - too fast		
Coarse sand or gravel	5 - 11	0.20	0.13	0.82
Fine sand	12 - 17	0.25	0.17	0.95
Sandy loam	18 - 23	0.40	0.27	1.22
Sandy clay	24 - 47	0.60	0.40	1.50
Clay with considerable sand or gravel	48 - 59	0.90	0.60	2.18
Clay with small amount of sand or gravel	60	1.20	0.80	2.72
	61+	not allowed - too slow		

## STEP 2: CALCULATIONS C - Site Planning [ref. 4]

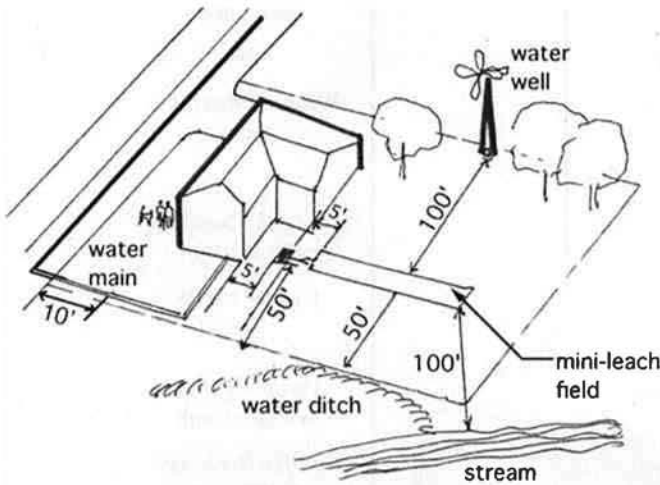

To locate your existing utility lines for your plot plan, call 811 or visit [www.call811.com](http://www.call811.com)

Minimum Horizontal Distance From	Surge Tank (feet)	Irrigation Field (feet)
Buildings or structures <sup>1</sup>	5 <sup>2</sup>	8 <sup>3</sup>
Property line adjoining private property	5	5
Water supply wells <sup>4</sup>	50	100
Streams and lakes <sup>4</sup>	50	50
Seepage pits or cesspools	5	5
Disposal field and 100% expansion area	5	4 <sup>5</sup>
Septic tank	0	5 <sup>6</sup>
On-site domestic water service line	5	5 <sup>7</sup>
Pressure public water main	10	10 <sup>8</sup>
Water ditches	50	50

**Notes:** When mini-leach fields are installed in sloping ground, the minimum horizontal distance between any part of the distribution system and ground surface shall be 15 feet.

<sup>1</sup> Including porches and steps, whether covered or uncovered, but does not include carports, covered walks, driveways and similar structures.

<sup>2</sup> The distance may be reduced to zero feet for aboveground tanks if approved by the Administrative Authority.

<sup>3</sup> The distance may be reduced to two feet, with a water barrier, by the Administrative Authority, upon consideration of the soil expansion index.

<sup>4</sup> Where special hazards are involved, the distance may be increased by the Administrative Authority.

<sup>5</sup> Applies to the mini-leach-field type system only. Plus two feet for each additional foot of depth in excess of one foot below the bottom of the drain line.

<sup>6</sup> Applies to mini-leach-field type system only.

<sup>7</sup> A two foot separation is required for subsurface drip systems.

<sup>8</sup> For parallel construction or for crossings, approval by the Administrative Authority shall be required.

<sup>9</sup> Minimum separation from highest known groundwater is five feet.

\*Drip systems may allow for a reduction in setbacks.

# PARTS OF A GRAYWATER SYSTEM

Collection of Graywater	Provide Surge Capacity	Filtration	Distribution	Using Graywater
Individual plumbing of laundry or shower/tub or sinks	gravity surge tank	Disk or in-line filter	Gravity fed	<i>Irrigation and aquifer recharge by</i>
-or-	-or-	-or-	-or-	
-or-	pumped surge tank	Bag, mesh or fabric filter	Pumped	Mini leach field
Dual plumbing whole house (especially recommended for new construction)	-or-	Grav. sand filter	-or-	-or-
	surge capacity in the distribution system (i.e. branched irrigation system)	-or-	Siphoned	Branched system
		Pressurized sand filter		-or-
				Watering Moat
				-or-
				Field consisting of a drip system
				-or-
				Reed bed
				-or-
				Washing machine sump
				<i>Use in the building (toilet flushing)</i>
				Cistern Mode
				-or-
				commercially available tank
				<i>Aquifer Recharge &amp; septic system relief</i>
				Galley System

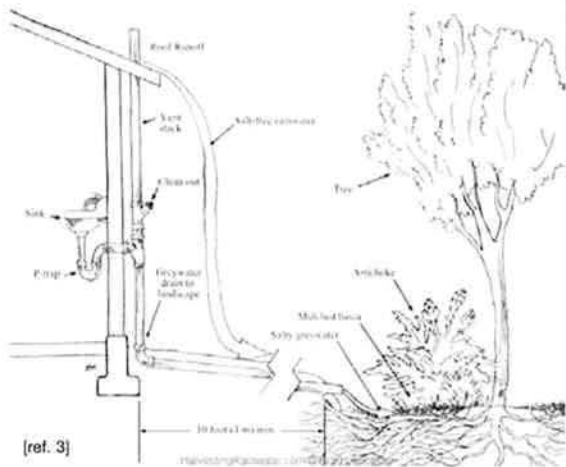

**Salt Build Up - What to do?**

Salt builds up in the soils of graywater systems, especially in warmer areas. Salt can be leached out by flushing the system with fresh water. You might be surprised to find out that approximately every 1000 square feet of property can yield 600 gallons of water in a 1 inch rain storm. By directing the flow of our roof's drip lines, gutters, and driveways into the landscape via depressions or basins, instead of mounds, the graywater system is flushed naturally and salt build up does not become a problem.



# DESIGN OF YOUR GRAYWATER SYSTEM

This page shows the basic components of all graywater systems and some options available to you. Choose the best option for your site, soil type, financial resources and maintenance preferences. Once a system is chosen, you can use the recipe cards for details of construction.

## NOTES:

## DIAGRAM OF SYSTEM OPTIONS

## REFERENCE RECIPE/PAGE CARD #

BASELINE CONSERVATION IS THE PREREQUISITE AND FIRST STEP IN GRAYWATER UTILIZATION.

GRAYWATER SHOULD NOT BE STORED BUT SHOULD BE UTILIZED AS FAST AS YOU CAN PROCESS IT.

ALL GRAYWATER SYSTEMS NEED TO HAVE A VALVE TO SWITCH TO YOUR SEPTIC OR SEWER SYSTEM.

THE SURGE TANK ALLOWS YOU TO TEMPORARILY HOLD GRAYWATER IF THE FLOW EXCEEDS YOUR ABILITY TO UTILIZE IT

DUAL FIELDS ARE USED IN LEACH AREAS FOR IRRIGATION TO GIVE ADEQUATE ABSORPTION TIME TO EACH SIDE. THE FLOW IS CONTROLLED BY A DISTRIBUTION OPTION SHOWN ON PAGE 11.

THE DRIP SYSTEM REQUIRES A PUMPED SURGE TANK TO MINIMIZE CLOGGING.

IN-HOUSE UTILIZATION CAN BE FOR TOILET FLUSHING WITH EXCESS FLOWS TO IRRIGATION SYSTEMS

ALTHOUGH NOT HELPFUL FOR IRRIGATION, A TRADITIONAL LEACH FIELD CAN BE USED TO TAKE SOME LOAD OFF OF A SEWER SYSTEM OR RECHARGE THE LOCAL AQUIFER.

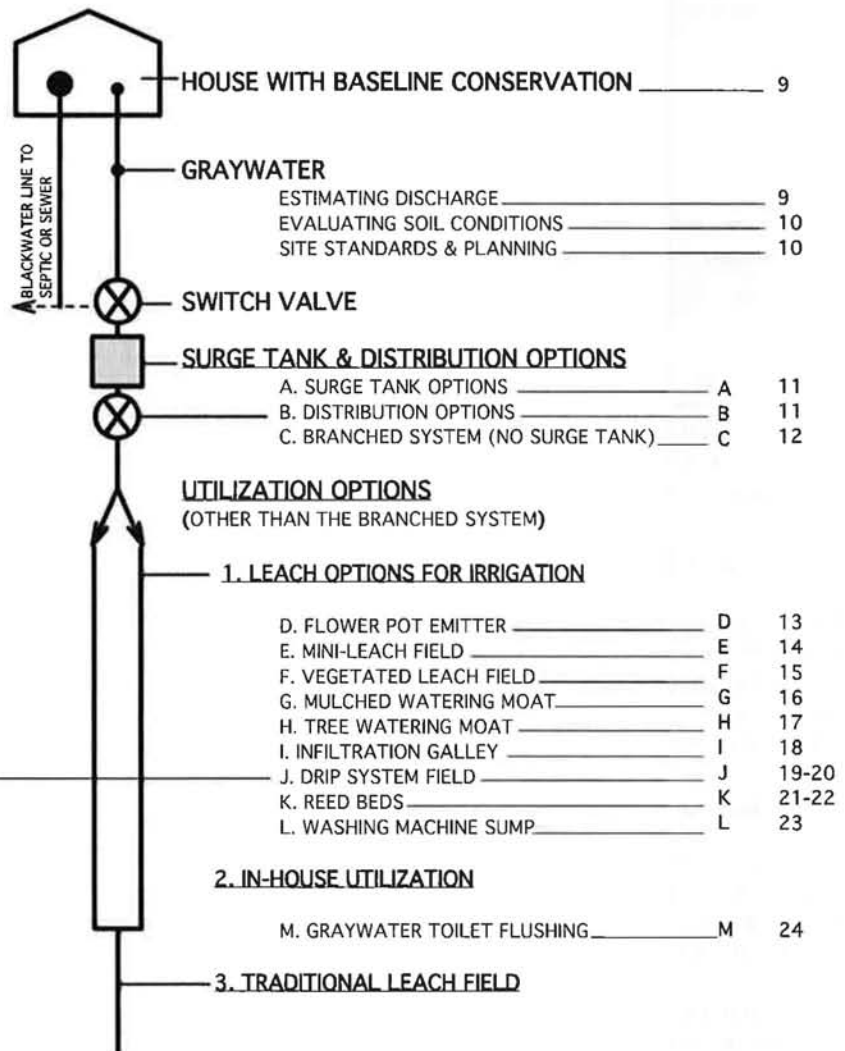

New technologies are constantly being refined and improved.

## A - SURGE TANK

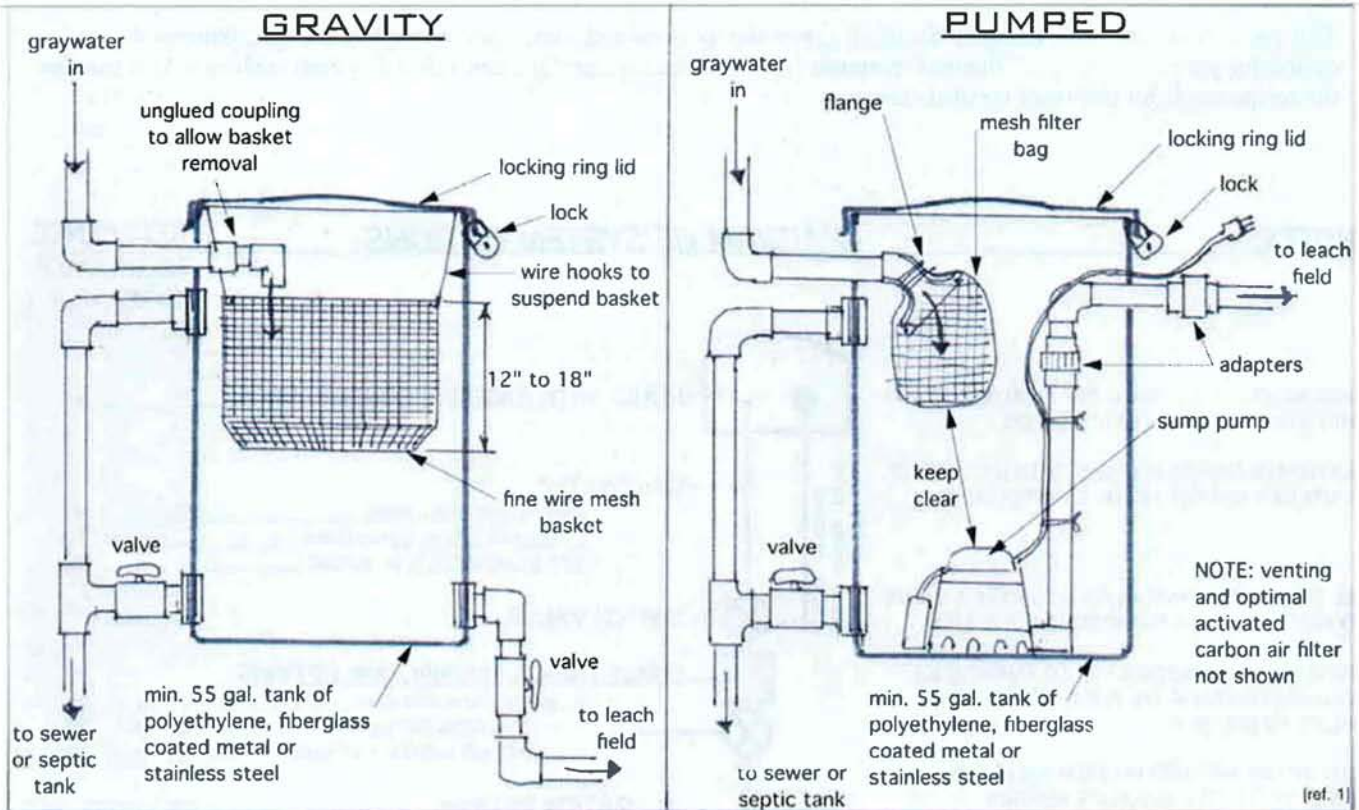

### SURGE CAPACITY

All graywater systems need to be able to handle the peak flows, or surge capacity, from the various plumbing fixtures. For most homes, a surge capacity of 45 gallons is sufficient. For instance, a 10-minute shower could generate 20-50 gallons of graywater at a time. Use the estimated daily flow rates as a guide for the surge capacity needed. If daily water use combines showers, bathing, and laundry all at the same time, the surge capacity should be adjusted accordingly. Graywater systems without sufficient surge capacity will cause pipes to backup.

### SURGE TANKS

Surge tanks are the standard solutions for providing surge capacity, usually ranging between 30 to 55 gallons. Specific construction details and requirements including a conceptual diagram are given in the plumbing code. The surge tanks shown in this guide are examples and might not include all the permit requirements such as venting, backwater valves, bracing, labeling, etc. Multiple tanks could be joined together to provide additional surge capacity.

In addition to the inlet and outlet ports, surge tanks also have an emergency drain valve and overflow outlet, which connect to the main sewer line. The overflow outlet should not have a valve and remain permanently open to the main sewer line, while other valves can be operated during cleaning and other maintenance activities.

Surge tanks can be gravity-fed or pump-based distribution as well as have various filter configurations. Inadequate filtration and clogged pumps are two issues with the pump surge tank. Using pumps designed for wastewater such as effluent pumps are expensive but last longer than cheaper well water or sump pumps. Filters should be sized to minimize the change-out/cleaning frequency. Even with the best level of filtration, subsurface drip systems are likely to clog over time, so systems using an automated sand filtration with backwash capabilities fair even better than the prescribed drip system from the plumbing code.

## B - DISTRIBUTION OPTIONS

Distribution is automatic in the branched system shown on recipe card C, but with the other absorption systems, distribution must be regulated to give adequate time to each absorption area. This is done by a distribution box (D-box). A distribution box evenly splits the flow of graywater between

absorption areas therefore they should be installed perfectly level on undisturbed ground. Pre-made D-boxes have 4" diameter inlet and outlet pipes with the inlet 1" higher than the outlets. Various options are shown below:

### Valve Control

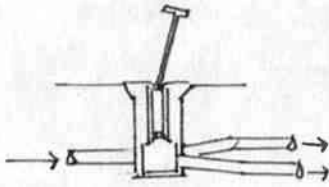

Flow is controlled by a valve which can be operated manually or electrically. Requires attention but does not need to be as level as the other options.

### "Y" Outlet

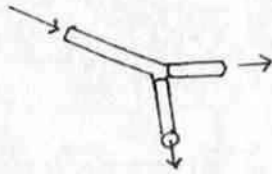

Automatic system for splitting flows equally between 2 absorption areas.

### D-Box w/ Multiple Outlets

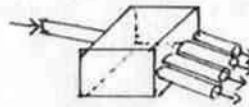

Automatic system for splitting flow equally between more than 2 areas.

### D-Box w/ Dipper Option

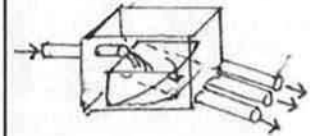

This system provides automatic 1.5 gal surge to help prevent the build up of solids. \* available commercially as Polylok dipper box.

[ref. 1]

## C - BRANCHED SYSTEM

### BRANCHED DRAIN SYSTEM

Surge capacity can be provided in the distribution plumbing and the receiving landscape if properly designed. Careful calculations are necessary to ensure that flow splitting and distribution piping function as intended and that piping fittings and slopes are installed properly. Constant slopes, adequately-sized outlets, and precise flow splitting are among the challenges with this approach to providing adequate surge capacity. The Branched Drain System, detailed by Art Ludwig, uses special double ell flow splitters, dipper boxes, and free-flow outlets such as a mulched moat system. Other emitters can also be used provided all the surge capacity is met. This option necessitates a sloped topography where lower elevation areas receive more water and should be planted accordingly.

This is the only system that doesn't require a surge tank since the capacity of the system is great

Various emitters such as the flower pot emitter, tree watering moat, or infiltration galley can be used at terminal ends of the branched system.

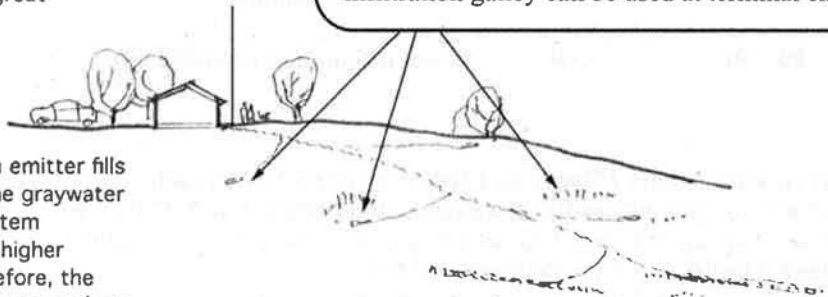

As the bottom emitter fills to capacity, the graywater fills up the system activating the higher emitters; therefore, the system must be on a slope.

Absorption by the use of mini-leach fields as shown in recipe card E is also possible.

[ref. 2]

THE FOLLOWING RELATIVE RATING GUIDE WILL HELP YOU COMPARE THE VARIOUS UTILIZATION OPTIONS, LOOK FOR THESE IMAGES AT THE TOP OF THE RECIPE CARDS:  
 LEAST (☉) TO MOST (☉☉☉) ENVIRONMENTALLY SUSTAINABLE  
 LOW (✖) TO HIGH (✖✖✖) COMPLEXITY OF DESIGN, INSTALLATION OR MAINTENANCE  
 LOW (\$) TO HIGH (\$\$\$) COST FOR MATERIALS

## D - FLOWER POT EMITTER

SUSTAINABILITY: 🌱🌍  
 COMPLEXITY: ✖✖  
 MATERIALS COST: \$\$

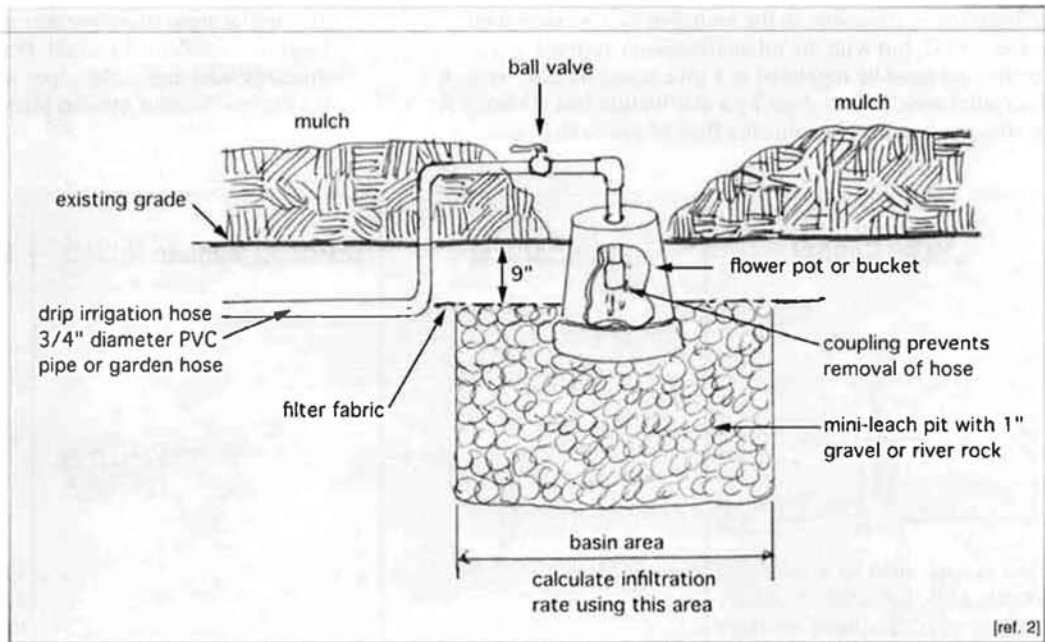

### TECHNOLOGY HIGHLIGHT

- Best suited for small tree or shrub groups with deep roots systems
- Works best with gravity surge tank, pumped surge tank or branched drain system
- Potential beneficial reuse of flower pots, buckets, or similar containers

The flower pot emitter is a passive outlet from the distribution lines after a surge tank (or branched drain system). If each emitter is at the end of a branching pipe, careful flow control is needed to prevent overflowing at any single outlet. Trees and shrubs with deep root system benefit the most from this simple system. Ball valves or other control devices can be used to regulate flow to each emitter.

### EXAMPLE OF DESIGN CALCULATIONS

Total graywater flow (4-bedroom house) at	200	gallons per day (gpd)
Sandy loam soil (see Percolation Rate Table) at	0.40	gpd per square foot
Required total area (i.e., $200 \times 0.40$ )	80	square feet
Design area for flower pot emitter	9	square feet per emitter
Minimum number of emitters (i.e., $80 \div 9$ )	9	flower pot emitters (rounded up)



### INSTALLATION

Fill a pit with clean gravel or river rock (minimum 1") at least 1 foot deep and 3 feet on each side. Cover the gravel with filter fabric. Place a flower pot (minimum 5 gallons) upside down on the filter fabric. Use 3/4" PVC pipe and a coupling to secure the pipe inside of the pot. Use a ball valve to help regulate the graywater flow to each emitter. Cover the gravel and filter fabric with mulch or soil at least 9 inches above the bottom of the flower pot.

### MAINTENANCE

Clear mulch or soil to expose flower pot, lift up and clean out any clogging material. Replace filter fabric if needed. Flush out pipes and ball valves with clean water when flow is restricted.

## E - MINI-LEACH FIELD

SUSTAINABILITY:   
 COMPLEXITY:   
 MATERIALS COST: \$\$

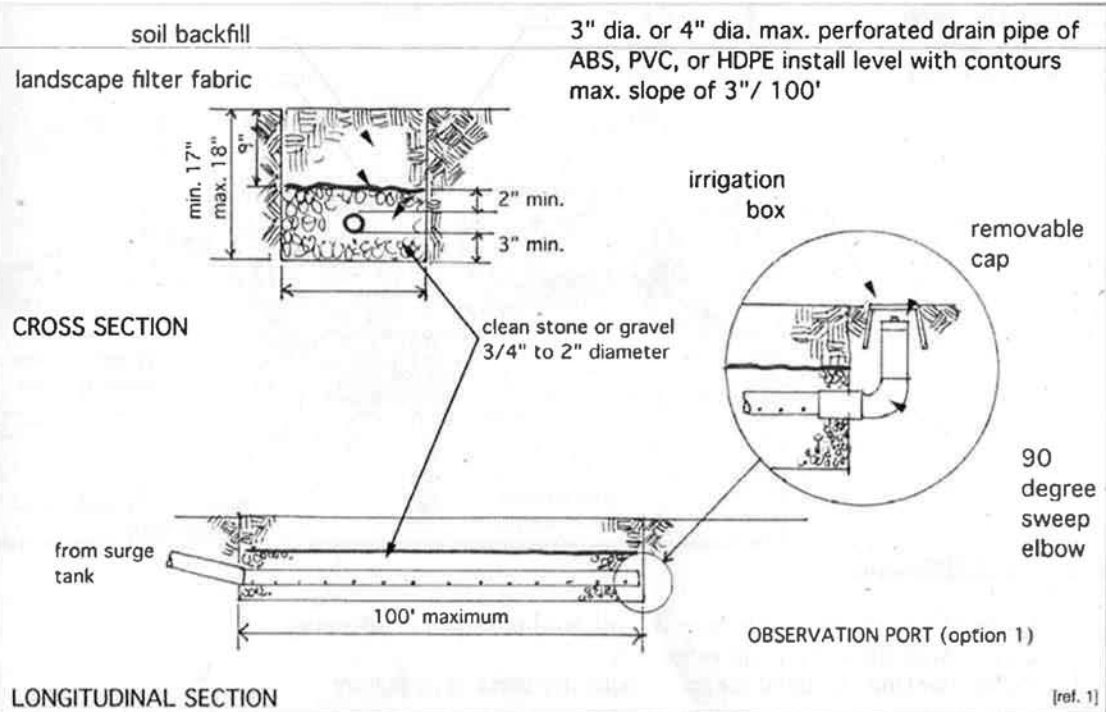

### TECHNOLOGY HIGHLIGHT

- Best suited for straight rows of vegetation
- Works best with filtered gravity surge tank
- Most beneficial for high flows, groundwater recharge or septic tank relief
- Detailed requirements provided in the plumbing code for simplified permitting

The mini-leachfield is a standard design similar to a septic system leachfield with a few differences, including shallower placement. The mini-leachfield has low irrigation efficiency (i.e., most of the water drains away instead of used by the vegetation). Factors such as root intrusion, clogging potential, and the amount of imported gravel or stone overshadow the maintenance and sustainability benefits (compared to other designs.)

### EXAMPLE OF DESIGN CALCULATIONS

Total graywater flow (4-bedroom house) at	200	gallons per day (gpd)
Sandy loam soil (see Percolation Rate Table) at	0.27	gpd per square foot for standard 18" wide trench
Required total area (i.e., 200 x 0.40)	54	linear feet (18" wide trench)

### INSTALLATION

Install valves to allow for switching between irrigation zones. Level each leach field along contours to allow for even distribution, with a maximum slope of 3" per 100'. Use non-corrugated PVC perforated pipe (minimum 3", maximum 4") with holes facing down. Install a 90 degree sweep elbow fitting to the surface with a removable cap as an observation port (optional). Fill a trench (minimum 12", maximum 36" width) with clean stone or gravel at 17" (or 18") below the surface for a 3" (or 4") PVC pipe. Place the PVC pipe on a 3" layer of gravel (3/4" to 2" diameter) with at least a 2" layer over the PVC pipe. Cover the gravel with filter fabric. Backfill with soil to the surface with a 9" minimum cover.

### MAINTENANCE

Remove invading roots using the observation ports when needed.

## F - VEGETATED LEACH FIELD

SUSTAINABILITY: ♻️ ♻️  
 COMPLEXITY: ✖ ✖  
 MATERIALS COST: \$\$

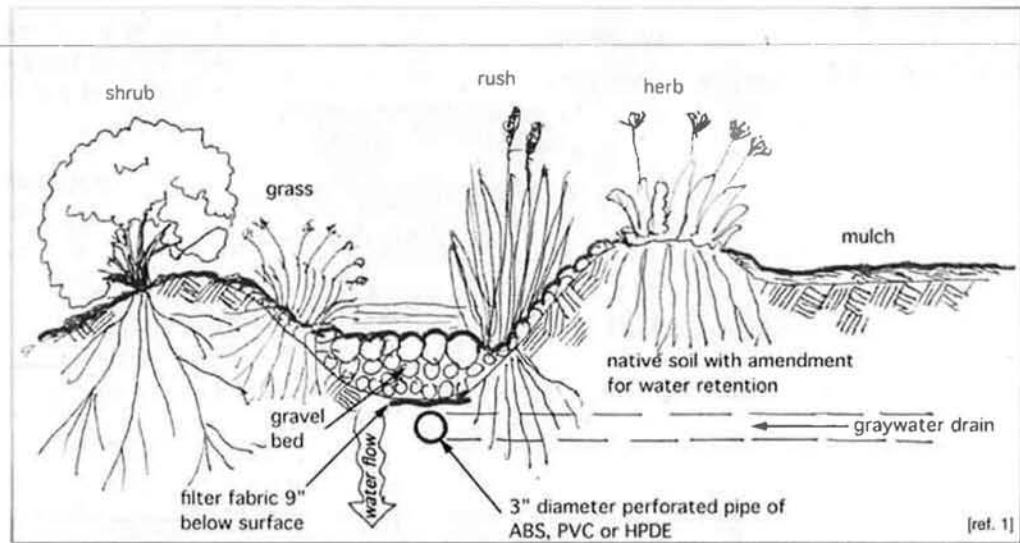

### TECHNOLOGY HIGHLIGHT

- Best suited for larger lots (or long runs) with well-designed landscaping
- Works best with filtered gravity surge tank
- Uses gravel or stone material for an aesthetic dry creek-type feature

The vegetated leachfield is similar to the mini-leachfield using perforated piping to distribute graywater to the surrounding landscape. Native grasses, sedges and shrubs suitable for wetland and drier conditions are located according to root access and proximity to the leachfield pipe. Stormwater flows along the swale during rainy periods to help flush out accumulated salt and sediment.

### EXAMPLE OF DESIGN CALCULATIONS

Total graywater flow (4-bedroom house) at	200	gallons per day (gpd)
Sandy loam soil (see Percolation Rate Table) at	0.40	gpd per square foot
Required total area (i.e., 200 x 0.40)	80	square feet
Design length for vegetated leachfield	0.5	square feet per linear foot of 6-inch wide trench
Minimum length required (i.e., 80 ÷ 0.5)	160	linear feet of vegetated leachfield Note: maximum single run is 100 feet

### INSTALLATION

Create a depression (swale) along contour lines in the soil and mounded sides. Lay down a French drain (3" perforated PVC pipe, non-corrugated) in a 6" wide trench at 6" below the swale bottom. Connect pipes from graywater and roof runoff sources at a minimum 2% slope. Cover perforated pipe with filter fabric to prevent clogging. Place amended soil on top of the planting areas. Plant wetland-type plants at the bottom of the swale and upland-type plants along the mounded banks. Cover entire swale with 4" to 6" river rock and gravel mulch, with at least 9" directly over the perforated pipe. Install vault boxes at the ends of the pipe runs.

### MAINTENANCE

Regular landscape maintenance and garden upkeep required during the growing seasons. Flush out at seasonal intervals and check for clogging and root intrusion. Most wetland plants get cut to the ground every winter. Trees and shrubs get pruned back as needed. Remove debris collected from vault boxes at the ends of the pipe.

## G - MULCHED WATERING MOAT

SUSTAINABILITY: ♻️ ♻️ ♻️

COMPLEXITY: ✖️

MATERIALS COST: \$

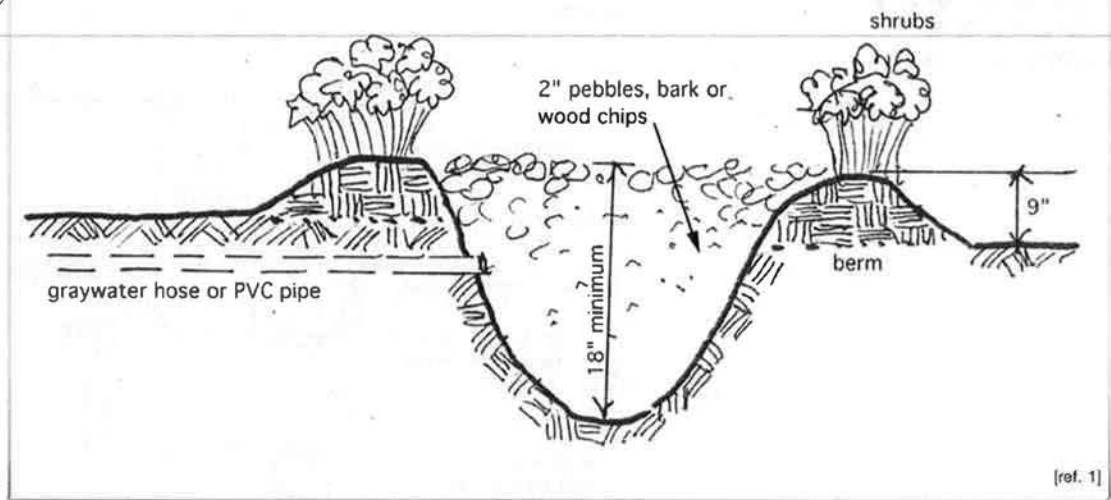

### TECHNOLOGY HIGHLIGHT

- Best suited for small flows from single individual plumbing sources
- Works best with filtered gravity surge tank or branched drain system
- Potential beneficial reuse of woods chips, bark, or other mulch material

The mulched watering moat is the simplest passive outlet yet requires regular maintenance to remove and replace decomposed mulch material. Whether plumbed from individual sources or an entire graywater system, each mulched watering moat needs to have well-draining soils (i.e., little or no clay) and sufficient surge capacity to prevent water from surfacing.

### EXAMPLE OF DESIGN CALCULATIONS

Total graywater flow (4-bedroom house) at	200	gallons per day (gpd)
Sandy loam soil (see Percolation Rate Table) at	0.40	gpd per square foot
Required total area (i.e., $200 \times 0.40$ )	80	square feet
Designed area for mulched watering moat	9	square feet per moat
Minimum number of moats (i.e., $80 \div 9$ )	9	watering moats (rounded up)



### INSTALLATION

Fill a pit with clean gravel, river rock, bark, or wood chips (minimum 2") 3 feet wide on each side at ground surface. Use soil to create a berm at least 9" above the surface, with a maximum 2:1 slope to the pit bottom. Place 3/4" PVC pipe at least 9" below the ground surface into the moat. Use a screen around the outlet area to keep out pests.

### MAINTENANCE

Flush the mulched moats periodically to reduce salt build up. Remove decomposed mulch material and replace with new material as necessary. Check for clogging and root intrusion at the pipe outlet.

## H - TREE WATERING MOAT

SUSTAINABILITY:   
 COMPLEXITY:   
 MATERIALS COST: \$\$

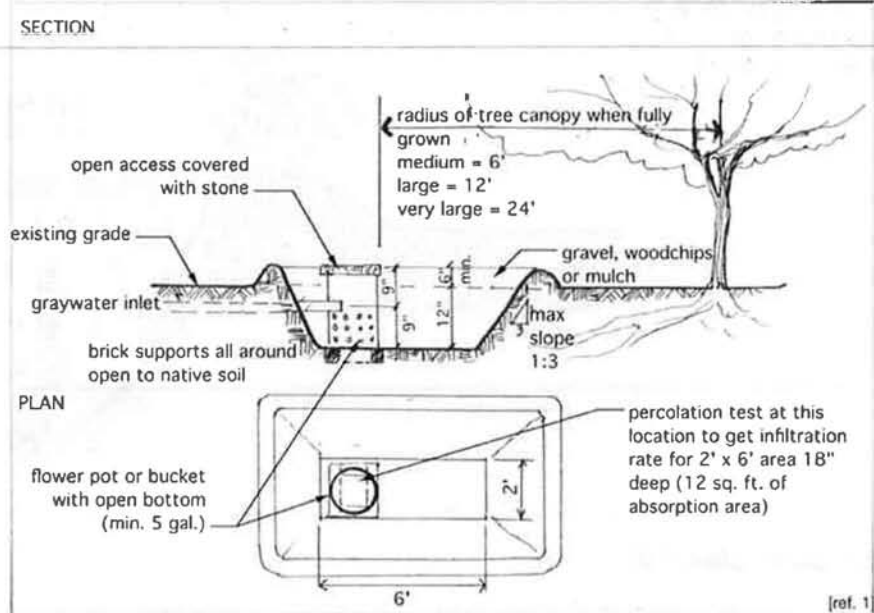

### TECHNOLOGY HIGHLIGHT

- Best suited for high flow volumes and irrigation of trees and large shrubs
- Works best with gravity surge tank or branched drain system
- Potential beneficial reuse of woods chips, bark, or other mulch material

The tree watering moat is similar to the flower pot design with a larger basin for better percolation. Each tree watering moat needs to have well-draining soils (i.e., little or no clay) and sufficient surge capacity to prevent water from surfacing. Planning the location of the moats requires knowing the tree canopy size (or dripline) at maturity.

### EXAMPLE OF DESIGN CALCULATIONS

Total graywater flow (4-bedroom house) at Sandy loam soil (see Percolation Rate Table) at	200	gallons per day (gpd)
	0.40	gpd per square foot
Required total area (i.e., 200 x 0.40)	80	square feet
Designed area for tree watering moat	12	square feet per tree watering moat
Minimum number of moats (i.e., 80 ÷ 12)	7	tree watering moats (rounded up)

### INSTALLATION

Dig a rectangular pit at 2 feet wide by 6 feet long at least 12" below the natural surface. Slope the sides at a maximum of 3 feet horizontally for each foot vertically and berm up extra soil for an additional 6" above the ground. Place 3/4" PVC pipe at least 9" below the ground surface into the flower pot or bucket emitter (see Flower Pot Emitter profile) with brick supports. Create an open access for bucket emitters covered with a heavy stone for easier maintenance.

Fill moat with clean gravel, river rock, bark, or wood chips (minimum 2"). Use roadside wood chips, composted municipal waste and recycled aggregate if possible. Locate each tree watering moat between 2/3 times and 1-1/2 times the radius of the tree canopy when fully grown. Use 6' for medium-sized trees, 12' for large trees, and 24' for very large trees. Keep water away from the trunk to avoid root rot.

### MAINTENANCE

Flush the tree watering moats periodically to reduce salt build up. Remove decomposed mulch material and replace with new material as necessary. Check the bucket emitter and remove any clogging material as necessary.



## I - INFILTRATION GALLEY

SUSTAINABILITY: ☺  
COMPLEXITY: ✖ ✖  
MATERIALS COST: \$ \$

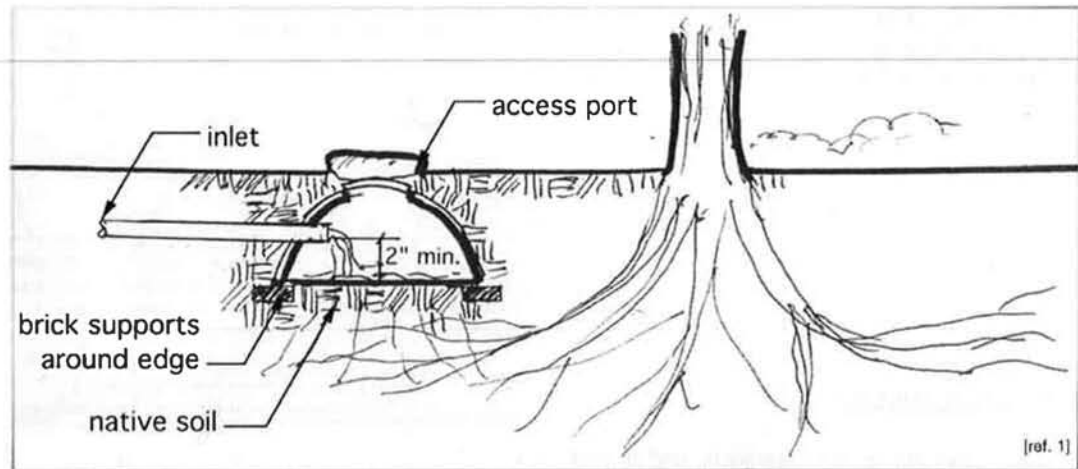

### TECHNOLOGY HIGHLIGHT

- Best suited for high flow volumes and irrigation of trees and large shrubs
- Works best with gravity surge tank, pumped surge tank or branched drain system
- Proven technology with septic systems

The infiltration galley uses half-cylinder structures, such as manufactured infiltrators, barrels cut in half, or large diameter pipes, to create a large void space beneath the soil. The large capacity also allows for more surge volume for each galley. Manufactured infiltrators can be linked together to reduce piping. Design and install prefab infiltrators according to the manufacturer instructions.

### EXAMPLE OF DESIGN CALCULATIONS

Total graywater flow (4-bedroom house) at	200	gallons per day (gpd)
Sandy loam soil (see Percolation Rate Table) at	0.40	gpd per square foot
Required total area (i.e., $200 \times 0.40$ )	80	square feet
Typical infiltrator disposal area (for example, 75" long x 34" wide x 12" deep)	17	square feet per infiltrator
Minimum number of infiltrators (i.e., $80 \div 17$ )	5	infiltrators (rounded up)

### INSTALLATION

Prefab infiltrator galleys should be installed according to the manufacturer instructions. Modify access ports and observation ports with stone markers for easier maintenance (optional). Alternative infiltration galleys include plastic 55-gallon drums cut lengthwise, large diameter plastic pipes cut lengthwise, and constructed box troughs; Construct with splash blocks, brick or mesh fabric supports (to keep galleys from sinking into the soil), and removable lids, if possible. Cover the galley with soil at least 9" from the bottom of the galley. Locate similarly to tree watering moat for tree irrigation (and away from tree trunks to prevent root rot.)

### MAINTENANCE

Check access ports (if available) for any clogging material and remove as necessary.

## J - DRIP SYSTEM

SUSTAINABILITY: 🌱🌍  
 COMPLEXITY: ✖✖✖  
 MATERIALS COST: \$\$\$

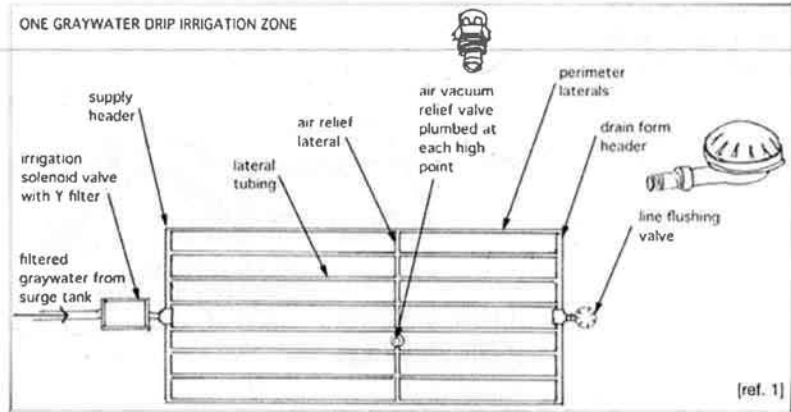

### TECHNOLOGY HIGHLIGHT

- Best suited for lawns, clay soils, and sloped sites
- Works best with filtered pumped surge tank
- Standard (prescribed) technology for graywater

A subsurface drip irrigation system is complex and also has the greatest potential for system failure. The drip system requires a well-maintained filter and a properly sized pumping system to prevent clogging. Further details on required equipment and materials are given in the plumbing code. Drip irrigation systems require at least 11 psi operating pressure, and generally include filters, tubing, valves, drip emitters, and controllers. Despite costs and maintenance, drip systems are highly efficient at irrigation, spreading the graywater over the largest possible area with the greatest control.

### EXAMPLE OF DESIGN CALCULATIONS

Total graywater flow (4-bedroom house) at	200	gallons per day (gpd)
Sandy loam soil (see Percolation Rate Table) at	1.22	gpd per square foot
Required total area (i.e., 200 x 1.22)	244	square feet (sf)
Emitter spacing, using 14" spacing in all directions	1.36	square feet per emitter
Minimum number of emitters (i.e., 244 ÷ 1.36)	180	emitters (spacing at 14" in all directions)

Note: Further drip system design is required to ensure that the pump cycling meets the graywater flow rate.

### INSTALLATION



Follow manufacturers instructions for installation of subsurface drip system equipment, including pre-filters, filters, pumps, drip tubing, and emitters. Pre-filters are an initial filter required to catch most of the lint, hair and particles found in graywater. This filter should be easily accessible for cleaning and replacement. They are commonly located at the inlet pipe in the surge tank. The surface area of the filter should be at least 2 square feet. Material can be PVC, polyethylene, woven mesh bag or paper canister filter.

Pump options available include a sump pump, a centrifugal pump or submersible high head effluent pump. Use pressure regulators to maintain the pressure below 25 psi, where most fittings must be kept to prevent damage. Multiple drip system zones are useful to reduce the pump size and provide better operations. Zoned assemblies have a limited number of running feet to maintain the necessary pressure. Stagger drip lines between 12-14" apart so that emitters alternate from row to row. Use manual ball valves or actuated diverter valves to help distribute the flow.

### MAINTENANCE

Check and clean all filters routinely. Flush system with clean water or slightly acidic solution several times a year at the beginning of each watering season. Check flushing valve periodically for sediments. Flush the Y-filter monthly. Check tubing for rodents, digging and other abrasion damage where surfaced tubing is visible.

## J - DRIP SYSTEM WITH PRESSURIZED SAND FILTER OPTION

SUSTAINABILITY:   
 COMPLEXITY:   
 MATERIALS COST: \$\$\$\$

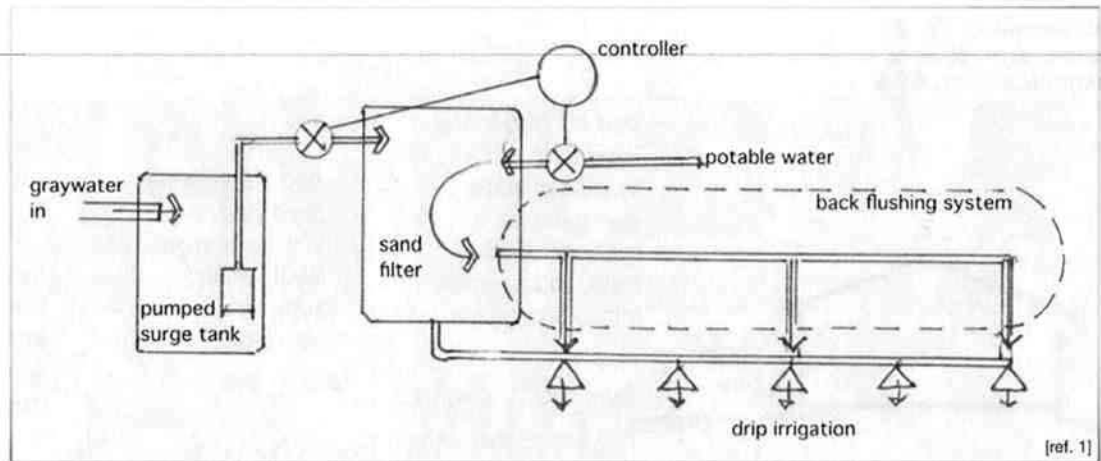

### TECHNOLOGY HIGHLIGHT

- Best suited for lawns, clay soils, and sloped sites
- Automated system with minimal maintenance or owner intervention
- Developed proprietary system with high rate of operational success

A subsurface drip irrigation system with pressurized sand filtration and automatic backflushing may be one of the best approaches for challenging projects. Drip systems with pressurized sand filtration require little maintenance compared to regular filter cleaning in surge tanks. The high degree of filtration (similar to swimming pool filtration) provides longer life of pumping equipment, drip lines, and emitters. Although relatively expensive and complex, this system achieves efficient irrigation with low maintenance.

### EXAMPLE OF DESIGN CALCULATIONS

Total graywater flow (4-bedroom house) at	200	gallons per day (gpd)
Sandy loam soil (see Percolation Rate Table) at	1.22	gpd per square foot
Required total area (i.e., 200 x 1.22)	244	square feet (sf)
Emitter spacing, using 14" spacing in all directions	1.36	square feet per emitter
Minimum number of emitters (i.e., 244 ÷ 1.36)	180	emitters (spacing at 14" in all directions)

Note: Further drip system design is required to ensure that the pump cycling meets the graywater flow rate.

### INSTALLATION & MAINTENANCE

The drip irrigation system with pressurized sand filtration is similar to the basic drip system, using a automatic sand filter vessel under pressure, automated backflushing with potable water, and special emitter cones (instead of in-line emitters). Follow the manufacturer instructions (provided by ReWater Systems). Anticipated maintenance includes checking yearly and, as needed, replacing the sand filter media.

## K - REED BEDS

SUSTAINABILITY: 🌱🌱  
COMPLEXITY: ✖✖✖  
MATERIALS COST: \$\$\$

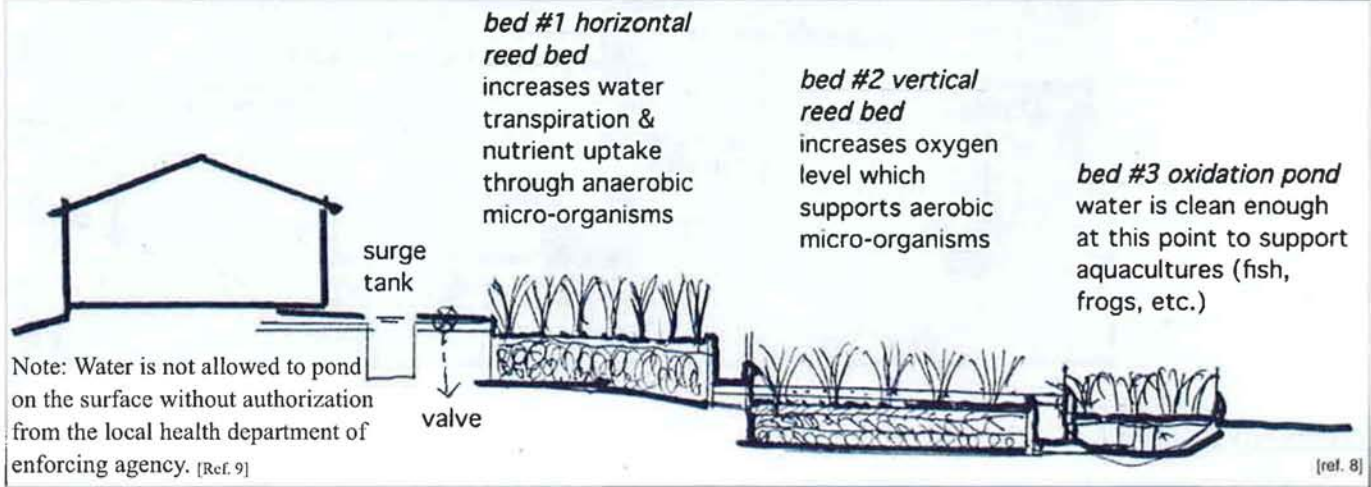

### TECHNOLOGY HIGHLIGHT

- Best suited for large areas with slow percolation rates
- Provides graywater treatment mimicking natural ecological systems
- Allows for better controlled plant growth and possible cultivation

Reed Beds, also known as constructed wetlands, are man made, engineered, marsh like area designed and constructed to treat wastewater. Wetlands are cost-effective, ecological systems, and simple to both install and operate. Reed bed systems are best when soil percolation is very low, space is limited and there is a need to treat large volumes of water. Reed beds provide a home for bacteria, fungus and microbes that digest effluent while deterring flow and retaining suspended solids. Reed beds can be designed as either horizontal or vertical. Horizontal reed beds allow water to enter one side of the bed and flow slowly across and through bed until reaching outlet on opposite side, which then flows into another bed or percolates into the soil.

Reed beds do not have much popularity in this country, thus partnerships and communication with the building department will be helpful. Vertical reed beds allow water to be evenly dispersed along the top of the soil profile. The water slowly percolates through a sandy, rock soil profile until it exits from below or simply percolates into the soil.

Reed beds provide an ecologically based filtration of wastewater while providing higher biodiversity and beauty. Reed beds when mature host various species of plants, homes to butterflies, dragonflies and other important species. Plants can be harvested for textile and building purposes. In dry areas reed beds provide a contrast to otherwise arid lands.

### INSTALLATION

Reed bed construction requires further research for proper design. Plant native species, such as members of the Cyperaceae, Junaceae and Typhaceae families. Aquatic plant species should also be selected based on the following criteria: rapid and relatively constant growth rate, ease of propagation, capacity of absorption of pollutants, ease of harvesting, potential for usefulness of harvested material, high oxygen transport ability, tolerance to adverse climate conditions and resistance to pests and disease. Do not plant invasive species.

Reed beds require a combination of vertical and horizontal reed beds. Horizontal beds increase water transpiration and nutrient, nitrogen and phosphorous, uptake through anaerobic micro organisms. Vertical reed beds increase the presence of oxygen which host aerobic micro organisms. All reed beds should have overflow zones for storm water conditions. After passing through the beds, install a pond supporting aqua-cultures for fish, frogs, and other ecology.

## K - REED BEDS

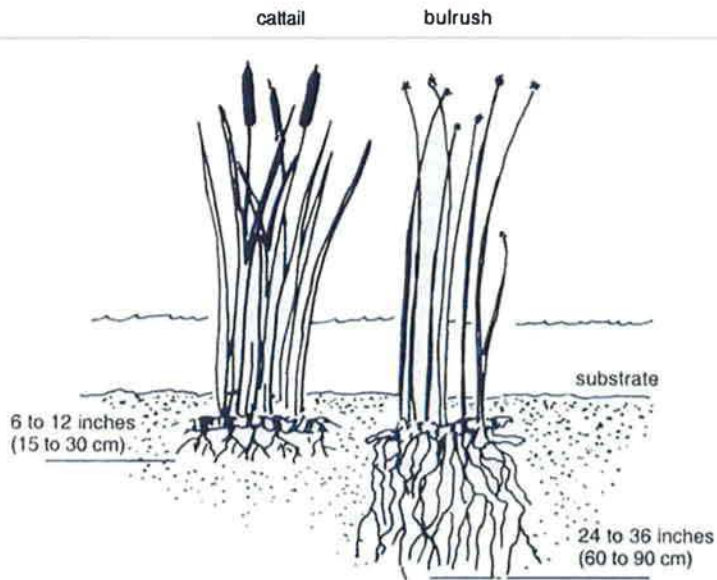

Typical rooting depth - cattail and bulrush (ref. 8)

Note: Water is not allowed to pond on the surface without authorization from the local health department of enforcing agency. [Ref. 9]

bed depth:  
12" for cattails  
24" for reeds  
30" for bulrushes

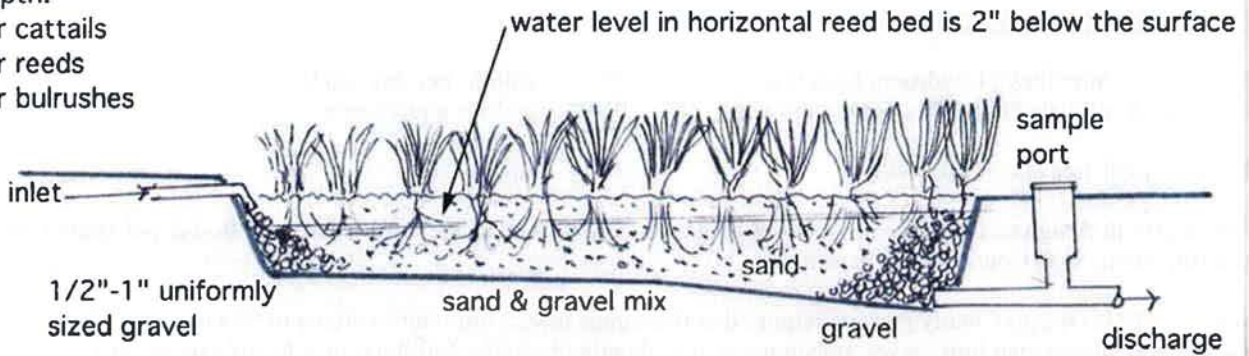

**HORIZONTAL REED BED**

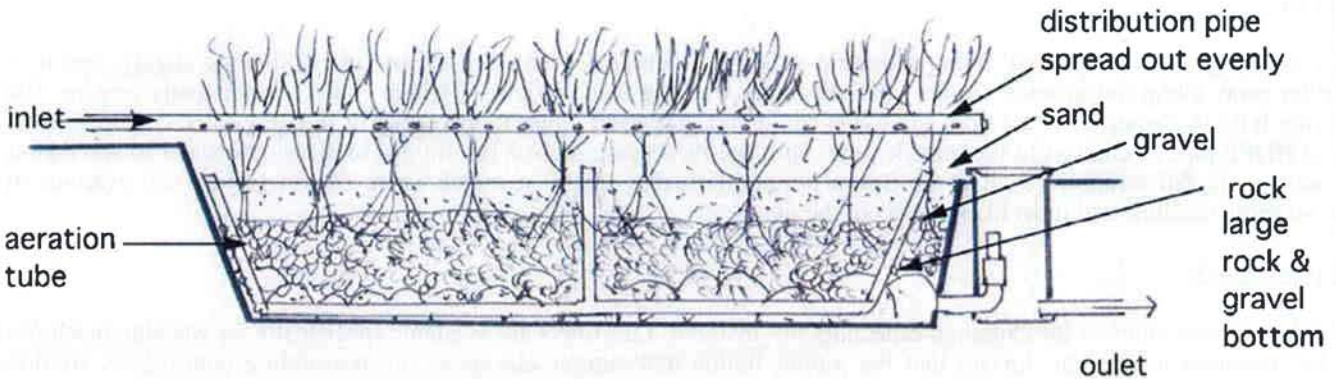

**VERTICAL REED BED**

## L - WASHING MACHINE SUMP

SUSTAINABILITY: ♻️  
 COMPLEXITY: ✖️  
 MATERIALS COST: \$

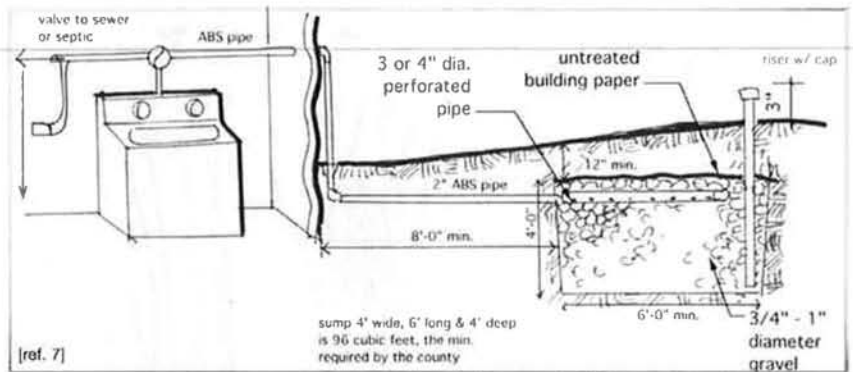

### TECHNOLOGY HIGHLIGHT

- Best suited for all projects, especially remodels and existing construction with slab foundations
- Minimal material and equipment saves on costs
- Basic system design allows for easy installation for most owners

The washing machine sump, also known as a drumless laundry system, is a simple design suitable for all houses with a standard washing machine. San Luis Obispo County permits this system as an alternative to a full dual-plumbed system. Most washing machines are located on exterior walls with access already. Alternative designs may include adaptability to various distribution and irrigation options, such as the flower pot emitter. Be careful to ensure that the pressurized surge capacity is included in design.

### EXAMPLE OF DESIGN CALCULATIONS

Washing machine flow (4-bedroom house) at	75	gallons per day (gpd)
Sandy loam soil (see Percolation Rate Table) at	0.40	gpd per square foot
Required total area (i.e., 75 x 0.40)	30	square feet

Continue with design calculations for selected irrigation option, such as the mini-leachfield, flower pot emitter, mulched watering moat, SLO County sump permit, etc.

Note: San Luis Obispo County permits require that the sumps have a minimum volume of 96 cubic feet. For more information, please visit [http://www.slocounty.ca.gov/planning/building/Building\\_details\\_info/septic.htm](http://www.slocounty.ca.gov/planning/building/Building_details_info/septic.htm)

### INSTALLATION

Material List: 1" brass three-way, 1" PVC pipe and fittings, check valve or "auto vent" used for air gap, swing check valve (if yard is higher than washer), 1" HDPE (black polyethylene plastic) tubing and barbed fittings, and 1" and 1/2" ball valves

The washing machine's internal pump pressurizes the graywater, so system can irrigate plants that are slightly uphill or further away along flat ground. Do not over stress the washing machine pump, which could require costly repairs. The washer hose is connected to a 3-way valve that can divert graywater either to the sewer or the graywater system. Use 1" rigid HDPE pipe to connect to the outside pipe. Split the flow using barbed Tee fittings to allow graywater to spread out to several freefall locations, such as the flower pot emitters, tree moats, or mulch basin. Drip irrigation will overburden the washing machine and most likely burn out the pump.

### MAINTENANCE

Check irrigation emitters for clogging, especially lint material. Lint filters are available specifically for washing machines if lint becomes a problem. Ensure that the piping friction and emitter elevations are not adding unnecessary friction resistance. Every 50 feet of run adds about as much resistance as 10" vertically. For example, a system that sends water through 100 feet of 1" pipe that ends up 12" lower in elevation than the lid is equivalent to pumping 8" above the lid of the washer (20" - 12" = 8").

## M - IN HOUSE USE OF GRAYWATER

SUSTAINABILITY: 🌱🌱🌱  
COMPLEXITY: ✖✖✖  
MATERIALS COST: \$\$\$

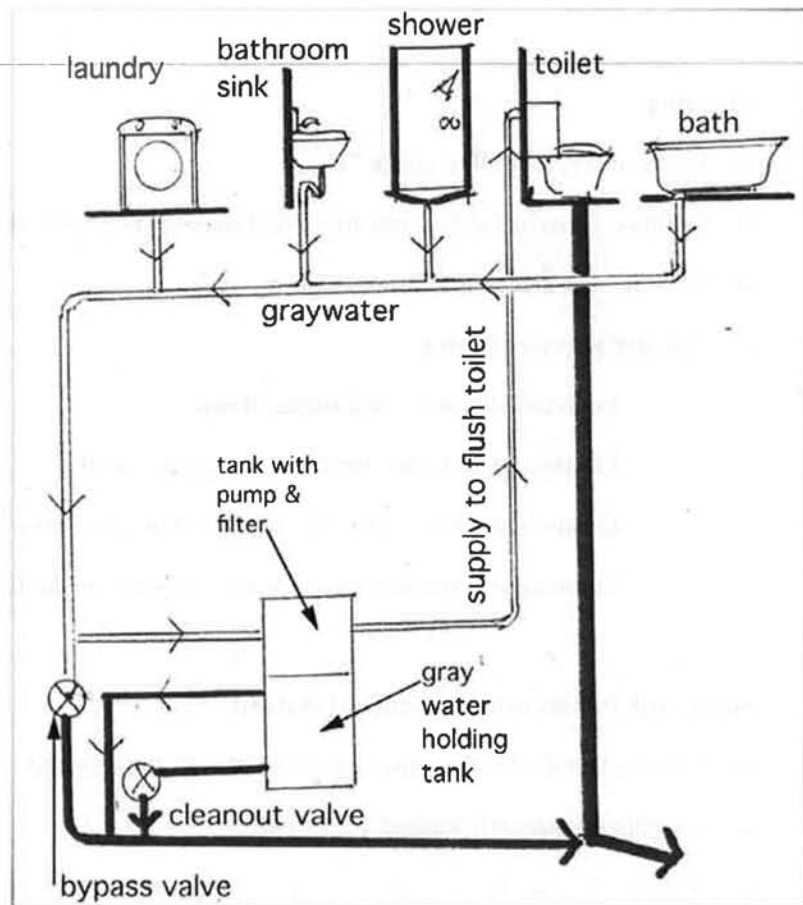

### TECHNOLOGY HIGHLIGHT

- Paired with irrigation reuse, indoor reuse systems can significantly reduce potable water use
- Mainly used for toilet flushing
- Proprietary systems are readily available and easy to install

Indoor reuse of graywater systems are primarily designed to treat and reuse graywater for toilet flushing. Some systems collect all the graywater (such as in a dual-plumbed house), provide treatment at a central location, and redistribute the treated stream to all the toilets. Other systems provide a direct connection from the adjacent sink and either treat and temporarily store the graywater for later flushing or allow the graywater water to be fill up the toilet tank immediately prior to flushing. Providing finer filtration coupled with chemical, UV or ozone disinfection allows longer storage time with graywater for toilet reuse. While most indoor reuse have been for commercial projects, residential systems are becoming more popular. [Ref. 9]

Most systems for indoor reuse are complex and expensive, compared to the basic systems used for irrigation, but may have greater environmental impact. Highly treated graywater that meets a certain purification standard in Canada, for example, is allowed for some non-potable uses, such as showers and swimming pools. Units are available for single family, shared central system located at co-housing or apartments.

### DESIGN, INSTALLATION & MAINTENANCE

Design, installation and maintenance of indoor reuse systems vary by manufacturer. Most systems are purchased through a vendor and installed by a professional licensed plumber. Some systems requires a minimum storage tank, where similar installation requirements with a surge tank may apply. Maintenance may require filter cleaning, handling of chemicals, and checking for clogging. For example, the Brac system consists of a pump, filter, and holding tank. The Pontos AquaCycle system includes aeration, disinfection, and filtration as well.

## GRAYWATER CHECKLIST

### **Planning**

- Estimate graywater flow (page 7)
- Estimate graywater absorption area based on soil type or percolation test results (page 8)
- Estimate distribution area for absorption
- Plot plan to scale showing
  - Lot lines, structures, and slopes of surfaces
  - Location of drainage channels, supply lines, wells
  - Location of sewage disposal system if applicable, plus 100% expansion area
  - Location of graywater system consistent with standards on page 8

### **Surge tank (unless using a branched system)**

- Anchored on dry level compacted soil or on a 3" concrete slab
- Capacity permanently marked on the tank
- "Graywater system – irrigation – danger unsafe water" permanently marked on tank
- Drain & overflow permanently connected to sewer or tank system
- Test surge tank to ensure it is water tight when filled

### **Utilization system of your choice**

- Insure that installation conforms to the plot plan
- Develop a maintenance manual and operating log



## S U M M A R Y

The demand for potable water is increasing and at the same time, climate change is making the consistency of water supplies less predictable. The effect is an increase in demand for imported water from distant sources which is associated with energy intensive and ecologically disruptive processes. The alternative to importing water usually means increased pressure on the local aquifer resulting in aquifer depletion.

This challenging situation forces us to produce and use water carefully. Reduce, reuse and recycle are concepts applied to consumer products; water should be thought of as one of these products, most importantly, it is the one product we must consume to survive. Graywater utilization is an important part of this effort to reduce, reuse and recycle water. Healthy and sustainable communities of the future will use graywater for all non-potable water uses such as irrigation and toilet flushing. Innovators today include REEF, well known for their contribution to the surfing industry, REEF's global headquarters in Carlsbad, CA, uses reclaimed water for irrigation and graywater for toilet flushing. Despite the fact that REEF doesn't own their building, they were able to integrate appropriate technologies yielding cost savings of \$200 per month on utility bills and lots of water saved for the future! [5]

In 2008, 20% of the electricity consumed in California was used to move and pump water. On-site harvesting and treatment of water can greatly reduce the amount of electricity used for this purpose. Graywater is but one appropriate technology that will enable us to meet the resource demands of today.

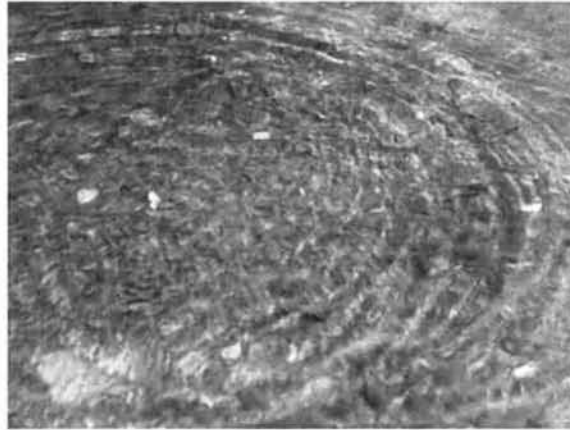

## R E F E R E N C E S

1. City of Malibu, Ca - Graywater Handbooks  
<http://www.ci.malibu.ca.us/index.cfm?fuseaction=detailgroup&navid=274&cid=2949>
2. Creating an Oasis with Graywater. Art Ludwig, Oasis Design, 2007.
3. Rainwater Harvesting for Drylands and Beyond. Brad Lancaster, Rainsource Press, 2008.  
[www.harvestingrainwater.com](http://www.harvestingrainwater.com)
4. 2009 California Plumbing Code- Appendix G
5. Carlsbad Magazine March/ April 2009
6. Carmichael Environmental Design/ Build
7. San Luis Obispo County Public Works Department
8. Constructed Wetlands in the Sustainable Landscape. Craig Campbell & Michael Ogden, Wiley & Sons, 1999.
9. *Proposed Express Terms - Emergency CPC (Title 24, Chapter 16A, Part I)- Graywater Standards*. Housing and Housing and Community Development (HCD). July 1, 2009.

When looking for appropriate detergents, read the following information regarding the contents.

### **Is Biodegradable Better?**

The word biodegradable means that a complex chemical is broken down into simpler components through biological action. Do not be confused by the word biodegradable, which is often used to imply environmentally safe. Harmful chemicals as well as beneficial ones may be biodegradable.

### **A Note About Chlorides**

Although chlorine in bleach and detergents is generally expended in the washing process, some may be left in the graywater that reaches plants. Chlorine should not be used in the garden because it may substitute for similar nutrients, blocking normal metabolic processes. The addition of chlorine to water used for irrigation should be kept to a minimum. Choose your detergents and clothes-washing products keeping in mind that it is better for your plants and soils to have a low alkalinity, boron, conductivity, and sodium content in the water. Personal preference may affect your choice of products since higher levels of these constituents may add to their cleansing ability.

### **Alkalinity**

Alkalinity refers to the relative amounts of alkaline chemicals in a solution. Sodium, potassium, and calcium are alkaline chemicals; they often are combined with carbonates, sulfates, or chlorides. Plants do not tolerate high concentrations of alkali salts.

### **Boron**

Boron is considered a plant micro-nutrient required in only very, very small amounts. Most soils provide adequate amounts of this chemical. Concentrations only slightly higher than those considered beneficial can cause severe injury or death to plants!

### **Conductivity**

Conductivity is a simple measure of the amount of dissolved chemicals in a solution. These chemicals can be beneficial or harmful. The higher the conductivity, the more dissolved salts and minerals are present. In general, the higher the concentration of dissolved salts and minerals in the water, the greater the potential for adverse affects on the environment and plant health.

### **Sodium**

Sodium can act as a plant poison by reducing the plants ability to take up water from the soil. Too much sodium can destroy the structure of clay soils, making them slick and greasy by removing air spaces and thus preventing good drainage. Once a clay soil is damaged by sodium, it can be very difficult to restore it to a viable condition.

### **Phosphate**

Phosphate is a plant food and is added to soil as a fertilizer. Soils in the San Luis Obispo area are typically low in phosphates; thus, there may be some benefit to plants if phosphate is present in graywater. However, this may be inaccurate since many forms of phosphate are not readily usable by plants and soils.

### **Some recommended products are:**

Alfa Kleen  
Bold  
Oasis  
Bio Pac  
Cheer Free  
Ecocover  
Shaklee Basic L  
Sun Ultra  
White King  
Yes

## A P P E N D I X 2 - PLANTS FOR GRAYWATER SYSTEMS

### Plant List - some recommended species by hydrozone:

#### Wetland Type—reeds, rushes, & sedges

Carex sp.—Sedge species—C. tumilicola, C. spissa, C. Praegracilis, etc.  
Juncus sp.—Rush species—J. patens, J. effusus  
Equisetum sp.—Horsetail species—E. hyemale (plant in container to keep from spreading)  
Canna sp.—Canna species—Hybrid colors (plant in container to keep from spreading)  
\*Chondropetalum elephantium—Cape Rush

#### Upland Type—herbs, shrubs, & trees

Arbutus 'Marina'—Strawberry Madrone Tree  
Cercis occidentalis—Western Redbud  
Myrica californica—California Wax Myrtle  
Rhamnus californica—Coffeeberry  
Heteromeles arbutifolia—Toyon  
\*Rosmarianus officinalis—Rosemary  
Artiplex sp.—Salt Bush species  
Arctostaphylos sp.—Manzanita species  
Ceanothus sp.—California Lilac species  
Salvia sp.—Sage species—S. spathacea, S. 'Pt. Sal', S. elegans  
Penstemon sp.—Penstemon species—P. heterophyllus, P. digitalis  
Achillea sp.—Yarrow species  
\*Lavandula sp.—Lavender species  
\*Fragaria chiloensis—Beach Strawberry

#### Grasses—used in both planting groups

Mulhenbergia rigens—Deergrass  
Festuca sp.—Fescue species—Blue Fescue, California Fescue  
Calamagrostis sp.—Reed Grass species—C. 'Karl Foerster', C. 'Overdam'  
Seslaria sp.—Moor Grass species—S. caerulea, S. autumnalis

**Note:** more common edible plants can be used as long as no edible parts touch the actual graywater flow. The foods produced above ground from plants rooted in graywater are just as fit to eat as plants grown in drinking quality water. Do not drink graywater!

\* Plants with an asterisk beside them are not native plants to California, but are climate appropriate species for San Luis Obispo County.

## GLOSSARY OF TERMS

**ADAPTER:** Any plumbing or drip irrigation part which connects one size pipe or part to another. Often used to refer to the female fitting, whether glued or threaded, which joins different parts together.

**ACTUATOR:** A 24V DC motorized valve, used to automatically control valves. Unlike a solenoid, this valve's opening and closing is powered by the motor, not the pressure in the pipe. Because it works without any water pressure in the pipes, it is the most practical valve for many graywater systems.

**AEROBIC SOIL:** A well drained soil with sufficient pore space to allow plenty of air circulation. The pore space is usually dependent upon the texture (sand is most open) and a reasonable amount of organic matter and humus.

**ANIONIC SURFACTANTS:** A cleaning agent, most commonly some form of sodium salt. Usually found in high sudsing detergents (see sodium chloride).

**BALL VALVE:** A valve which has a globe shaped rotating interior. The solid globe has a circular tunnel through it. When the handle of the valve is rotated, the solid portion of the ball cuts off the flow of water. Another rotation lines up the tunnel and water flows through the valve. Ball valves are often found at the discharge port of quality y-filters. Because ball-valves shear off any contaminants and because they don't easily wear out like gate valves, they are the preferred valve for graywater systems.

**BEACHFRONT AREAS:** Areas with a sand profile versus a soil profile.

**CENTRIFUGAL PUMP:** A pump installed outside the surge tank, not submersed in the graywater. The centrifugal pump along with a diaphragm pressure tank should be housed in or under a weatherproof structure.

**CHECK-VALVE:** A backflow preventer which stops any water siphoning back toward the house. Often not legal as the only backflow preventer in potable-water drip system. Must be coupled with some form of atmospheric vacuum breaker.

**DRIP:** A style or technology of irrigation where a tiny trickle of water is slowly applied to the soil.

**DRIP HOSE ADAPTER:** The first fitting after the main assembly of a drip irrigation system. Almost always an FHT (female hose thread) swivel X drip hose adapter. The female hose threads of the swivel go on to the male hose threads of a hose-bib or a transition nipple. The swivel action makes it easy to quickly add or remove this fitting. The other side of the adapter is either a slip (glue), or compression, depending on the system.

**DRIP LINE:** A length of solid drip irrigation hose or in-line emitter tubing.

**DRIPLINE:** The width of a tree's or shrub's foliage, where water would drip off the edge of the canopy. Not an indicator of the width of the root system as roots grow from one half to three times wider than the dripline.

**DUAL PLUMBING:** A permanent separate set of pipes for all the graywater sources in the home.

**ELBOW:** A fitting which allows drip hose or pipe to make 90 degree turn.

**EMITTER:** The little gizmos attached to or built in to solid drip irrigation hose which control the flow of water to the soil. There are many name brands that basically fall into four generic styles or technologies: single diaphragm, double diaphragm, tortuous (or complex) path, or simple orifice.

**END CAP:** The fitting added at the end of a lateral to make it easy to open the tubing for draining or flushing. Has a female hose thread cap with a washer which threads on to the male hose thread fitting. The other end will be either a compression, insert or other opening, depending on the system you use.

**EVAPOTRANSPIRATION (ET):** The loss of water from a plant or crop via transpiration (exhaling) by foliage and evaporation from the plant's and soil's surface. The ET rate is influenced by humidity, rainfall, slope aspect, wind speed, temperature, plant care and soil.

**FIGURE EIGHT END CLOSURE:** A simple end closure which involves threading the end of the drip hose through one side of the figure eight, bending over the end of the end of the drip hose and securing the bent end inside the other half of the figure eight.

**FILTER:** A device with a screen (cheap, poor quality models have plastic screens) which is used to trap any particulates, dirt, or scum before it can enter the drainfield or clog the drip emitters. An essential component of all graywater drip systems.

**FHT:** Plumbing shorthand for a female iron pipe thread.

**FLAPPER CHECK VALVE:** A valve that prevents any water from siphoning back into the surge tank.

**GFI:** A ground fault interrupt outlet. All sump pumps must be plugged into a GFI outlet.

**HEAD:** A pump's head is the gross difference in elevation which it pumps. As a safety factor, the head for a graywater system is determined by adding the total changes, both up and down, in the elevation from the surge tank to the point of disposal. To this figure add at least 15% more feet of the total head.

**HOSE-BIB:** Another name for a garden faucet. The standard gizmo on the pipe sticking out of the house's exterior wall or on top of a metal water pipe in the yard and onto which the garden hose is attached.

## GLOSSARY OF TERMS

**HOSE SHUT-OFF VALVE:** A small ball-valve which can be added at the end of a hose to control water without having to run back to the hose bib. With a few extra parts, this valve can be spliced into any drip hose and allow the gardener to exclude water from portions of a system. Often used to rotate graywater to different zones as needed.

**IN-LINE EMITTER HOSE:** A more recent and effective type of drip irrigation hose where the emitters are manufactured inside the hose at regular intervals. The pre-spaced emitters use a tortuous path technology for water regulation without clogging. Water can be distributed at 1/2, 1, and 2 gal/hr. rates at many separate intervals ranging from 12-72 inches.

**INSERT FITTING:** These fittings have male-shaped parts with barbed exteriors which insert inside the drip irrigation hose. As the water pressure increases, the fitting is more likely to fail because the swelling drip hose can bloat away from the barbed posts. Must use a ring clamp to secure the hose against too much pressure.

**J-STAKE:** A landscape pin used to secure drip irrigation hose, landscape netting and 12v DC wiring. Made like the upside version of the letter 'J', not as sturdy as the best U-stakes.

**LABRYINTH:** A complex, tortuous path inside certain emitters. The labyrinth of passages keeps any sediment in the water in suspension to pass out the emitter's orifice. All in-line emitter tubing uses some form of labyrinth to allow for a relatively large emitter orifice and to keep the emitter from clogging.

**LATERAL:** A lateral is a water-bearing pipe or drip hose which originates as an offshoot of a main supply pipe. Laterals are usually attached to the supply header via a tee.

**MAIN ASSEMBLY:** The collection of parts at the beginning of a graywater system which filters the graywater system to the drip emitters and regulates the water pressure to keep the drip system intact. Composed of a filter and pressure regulator plus the miscellaneous parts needed to connect everything together.

**MAIN SWITCHING VALVE:** A main valve is required to allow the homeowner to alternate between the graywater system and the septic tank or sewer. Use the main valve when the ground is saturated with rainwater, when someone is ill with an infectious disease or the occupants don't want to use the graywater irrigation system. The main valve, whether manual or electro-mechanical, is best plumbed near the surge tank.

**MESH:** Most drip irrigation filters are rated by mesh size. The larger the mesh number, the better the filtration because smaller particles can be trapped. Many metal screen filters are either: 60 mesh (254 microns or .01 inches), 100 mesh (152 microns or .006 inches), 140 mesh (104 microns or .004 inches) or 250 mesh (61 microns or .0024 inches). Graywater systems should use a 200 mesh or better filter.

**MICRON:** A common measurement for irrigation parts. The bigger the micron number, the bigger the opening. A single

micron equals one-millionth of a meter. It takes 254 microns to equal .01 inches, which is a 60 mesh screen. Most graywater systems should have a 75 micron or better filter.

**MIPT:** Plumbing shorthand for a male iron pipe thread.

**NIPPLE:** Comes in plastic and iron versions with male iron pipe threads on each end. Plumbing nipples range in size from 3/4 inches to 48 inches. Used to join two female iron pipe threads together.

**OVERFLOW PORT (AUTOMATIC):** An overflow pipe near the top of the tank dumps graywater to the sewer or septic tank in case something clogs the surge tank or the sump pump fails.

**PATHOGENS:** Disease causing organisms. To become infected, an individual must be exposed to a large enough dosage and be vulnerable to the pathogen. Most pathogens can reside out of the body of a host, in the soil, but each disease has a different life span in the soil.

**PERCOLATION TEST:** A test to determine the ability of the soil to accept graywater. The test is only required at the request of the City Health Officer. Percolation tests can be useful but they may not reflect long term acceptance rates.

**PHYTOPHTHORA:** Genus of various species of fungal diseases which attack the upper portion of the roots to destroy the bark's active layers of transport. Often called crown rot.

**POROUS HOSE:** Unlike an emitter, where the water dribbles out at select points; the water in porous drip hose oozes out through the entire surface area of the hose's walls. The genre of drip hose only works well with chlorinated city water because it's so prone to getting clogged by sediment and becoming sealed off internally due to the build-up of various types of algae slimes. Not recommended at all with graywater, no matter how well filtered.

**POTABLE WATER:** Fresh drinking water, city or pure well water.

**PRESSURE COMPENSATING EMITTER:** A special type of emitter engineered so that the flow rate stays the same regardless of the length of the line (up to a point) and any change in elevation. Required when irrigating landscapes with a total elevation change of 20 feet or more.

**PRE-FILTER:** Usually a basket with a mesh bag which catches most of the offending lint, hair and particulates before entering the surge tank. Its filtering surface area should be at least 2 square feet so that it does not clog quickly. The bigger the pre-filter, the better. Must be used with a graywater drip irrigation system.

**PRESSURE REGULATOR:** A gizmo which reduces the water pressure in a graywater drip irrigation to 25 psi or lower to protect the subsequent drip irrigation fittings. Must be installed in every main assembly.

## GLOSSARY OF TERMS

**PSI:** Pounds per square inch, the unit of measure for water pressure. Typical home water pressure is 40-80 psi. Drip irrigation systems generally operate at 11-25 psi.

**PVC:** A type of semi-rigid plastic that is made from polyvinyl chloride which is often used for garden plumbing. Some of the more common grades of this pipe (from the sturdiest to the weakest walls) are Schedule 80, Schedule 40, Class 200 and Class 120, which resist bursting up to, respectively, 800, 400, 200 and 120 psi.

**SALINE WATER:** Irrigation or ground water which is high in salt (sodium chloride). While saline water is useful in many medical applications, it is not healthy for many plants. Graywater can be particularly saline due to the salts in many detergents, especially powdered detergents.

**SCH:** Shorthand for 'schedule'. Used to denote the type or grade of PVC pipe and fittings.

**SLIP:** A PVC fitting with an opening which requires glue, as opposed to threads with pipe dope, to 'weld' the two parts together. Usually the end of the rigid PVC irrigation pipe and the fitting are moistened with PVC glue and the pipe is slipped into the wet round opening of the waiting fitting.

**SOLENOID:** An electric valve used to control drip irrigation systems. The wires to the solenoid usually carry 24 volts of AC power. The irrigation controller has a transformer to step down the house current. It is dependent on the static line pressure of the water supply to assist in the opening and closing of the valve, therefore they often can't be used with a graywater system unless the system is fully pressurized at all times.

**SPAGHETTI TUBING:** A tiny or slender type of polyethylene tubing which can be used to distribute water to emitters or plants. Comes in 1/4 and 1/8 inch diameters. Because of this tubing's propensity to twist around itself, it will make a tangled mess in the landscape. Can be controlled when used in container plantings.

**SUB-SYSTEM:** A branched system of drip irrigation laterals originating from a main supply line or header. Unlike a single lateral, a sub-system, also called a sub-main, has several subordinate lines all connected by tees in a pattern similar to the lines on a sheet of music.

**SUBMERSIBLE HIGH-HEAD EFFLUENT PUMP:** A 4 inch diameter submersible turbine pump made of stainless steel and high quality thermoplastics specifically for pumping wastewater effluent. Develops higher pressures than sump pumps.

**SUMP PUMP:** A pump designed to be submerged in water, to automatically turn on when the water reaches a predetermined level and to pump the water a certain maximum height and distance at a specific rate in gpm of gph. Installed in the surge tank.

**SUPPLY HEADER:** The solid plastic pipe, solid drip hose or in-line drip irrigation hose which supplies one or more laterals.

**SURFACE:** Refers to the top of a thick permanent mulch covering the soil or the top of an un-mulched soil. Graywater must not daylight on the surface.

**SWIVEL:** The rotating fitting that can be screwed onto another fitting. Usually refers to female hose threads which are threaded onto the end of a hose, hose-bibs or drip irrigation parts. Usually requires a rubber gasket in the swivel to prevent leaks.

**TEE:** A fitting which joins a lateral line (solid PVC pipe, in-line emitter tubing or solid drip hose) to another water supply line.

**THREE WAY SWING DIVERTER VALVE:** A spa type swing gate valve which comes in manual form or with a 24V DC actuator for automatic control. Used to divert graywater flow from one zone to another zone.

**TIMER:** A battery powered controller which controls one irrigation line. Attaches to the hose-bib and controls the flow of water to a hose or drip irrigation system.

**TORTUOUS PATH EMITTERS:** Drip irrigation emitters with a complex, tortuous or labyrinth path within the emitter which allows larger particles to flow through the emitter without clogging. Best emitter for use with graywater and one of the more recent developments in drip technology.

**TRANSITION NIPPLE:** A plastic or metal fitting with a male hose thread and a male iron pipe thread used to connect conventional garden plumbing to drip irrigation fittings.

**TWO-WAY SWING DIVERTER VALVE:** A spa type swing gate valve which comes in manual form or with a 24V DC actuator for automatic control. Turns graywater flow on and off.

**U-STAKE:** A landscape pin used to secure drip irrigation hoses, landscape netting and 12V DC wiring. Shaped like an inverted 'U', sturdier than the J-stakes.

**UNION:** Related to a coupling, a union is a plumbing part which, after unthreading the locking ring, separates into two pieces and allows you to take a portion of any irrigation system (providing there is a union on each end of the section) out for repairs without having to cut the pipe. The use of unions allows for the quick reinstallation of the repaired section without having to re-glue with extra fittings.

**WET SPOT:** The wet spot in drip irrigation has both depth and breadth, the extent of which is dependent upon the rate of the dribble (in gph), the duration of the trickle (in hours), the soil type, the slope of the land and the climate.

**Y-FILTER:** The best type of filter for a graywater drip irrigation system Easily identified by the filter chamber which is integrated into the filter at an obtuse angle. The best y-filters have a metal-screen filter within the filter chamber to make it easy to flush out the screen.

TO: COMMITTEE MEMBERS  
FROM: DON SPAGNOLO   
DATE: AUGUST 6, 2010

**AGENDA ITEMS**  
**3**  
**AUGUST 9, 2010**

UPDATE: CONSERVETRACK WATER CONSERVATION SOFTWARE

**ITEMS**

Discuss ConserveTrack water conservation software.

**BACKGROUND**

ConserveTrack water conservation software has been undergoing modifications and fine-tuning to enable the software to best suit the District's needs. As more is learned about the program, the number of possible uses continues to increase.

**RECOMMENDATION**

Discuss ConserveTrack, make recommendations, and continue to periodically update progress with the software program.

**ATTACHMENTS**

*Water Consumption: DUN0016.*  
*Comparing Consumption, BLV0001, 2005-2007.*

## Water Consumption: DUN0016

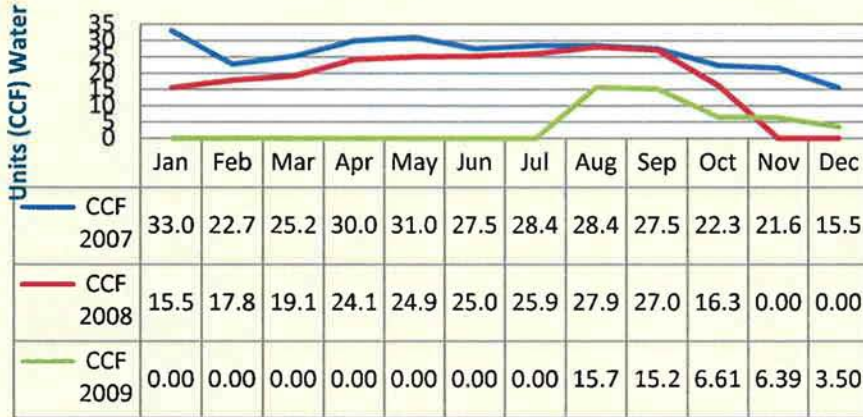

Month	CCF 2007	CCF 2008	CCF 2009
Jan	33.00	15.50	0.00
Feb	22.78	17.88	0.00
Mar	25.22	19.12	0.00
Apr	30.00	24.10	0.00
May	31.00	24.90	0.00
Jun	27.54	25.08	0.00
Jul	28.46	25.92	0.00
Aug	28.46	27.95	15.75
Sep	27.54	27.05	15.25
Oct	22.36	16.32	6.61
Nov	21.64	0.00	6.39
Dec	15.50	0.00	3.50
<b>TOTAL:</b>	<b>313.50</b>	<b>223.82</b>	<b>47.50</b>



### Comparing Consumption for BLV001 (APN-091411006) , Years 2005 to 2010

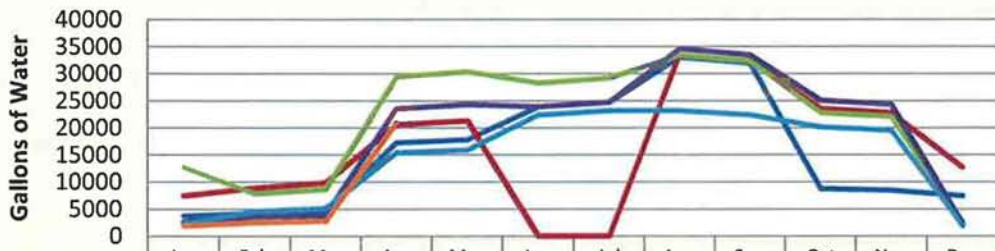

	Jan	Feb	Mar	Apr	May	Jun	Jul	Aug	Sep	Oct	Nov	Dec
— Yr2005	3740	4260	4716	17290	17866	23911	24709	33071	32005	8743	8461	7480
— Yr2006	7480	8875	9825	20601	21287	0	0	33452	32372	23568	22808	12716
— Yr2007	12716	7810	8646	29430	30410	28326	29270	33452	32372	22808	22072	2618
— Yr2008	2618	3615	3865	23544	24328	23911	24709	34592	33476	25089	24279	2244
— Yr2009	2244	4615	5109	15450	15966	22440	23188	23188	22440	20147	19497	1870
— Yr2010	1870	2485	2751	20969								

### COMPARING CONSUMPTION FOR BLV0001 (APN 091411006), YRS 2005-2010

	Yr2005	Yr2006	Yr2007	Yr2008	Yr2009	Yr2010
Jan	3740	7480	12716	2618	2244	1870
Feb	4260	8875	7810	3615	4615	2485
Mar	4716	9825	8646	3865	5109	2751
Apr	17290	20601	29430	23544	15450	20969
May	17866	21287	30410	24328	15966	
Jun	23911	0	28326	23911	22440	
Jul	24709	0	29270	24709	23188	
Aug	33071	33452	33452	34592	23188	
Sep	32005	32372	32372	33476	22440	
Oct	8743	23568	22808	25089	20147	
Nov	8461	22808	22072	24279	19497	
Dec	7480	12716	2618	2244	1870	
<b>Total</b>						
<b>Gallons</b>	186252	192984	259930	226270	176154	
<b>Total</b>						
<b>CCF/Units</b>	249.0	258.0	347.5	302.5	235.5	

TO: COMMITTEE MEMBERS  
FROM: DON SPAGNOLO   
DATE: AUGUST 6, 2010

**AGENDA ITEMS**  
**4**  
**AUGUST 9, 2010**

**UPDATE: STATE LEGISLATION PERTINENT TO NCSD**

**ITEMS**

Six California State Legislature bills, pertinent to the District, passed and chaptered in 2009.

**BACKGROUND**

Periodic review of six chaptered bills to monitor for changes, issues, and related news. No changes or news issues since the bills were chaptered.

- A. SB407 (Water-efficient plumbing requirements).
- B. AB 474 (Allows a public agency to enter into a contractual agreement with homeowners for a loan from the agency to finance permanent water-efficiency changes to their property).
- C. AB 1061 (Supports the Model Water Efficient Landscape Ordinance (MWELo) legislation by forbidding a homeowners' association, city, or other common interest development from requiring landscapes which are in conflict with the MWELo).
- D. AB 1366 (Authorizing local agencies providing wastewater treatment services to control salinity inputs from residential self-regenerating water softeners).
- E. SB6X7 (Groundwater monitoring program).
- F. SB7X7 (Defines specifics of requirements and documentation for the "20x2020" program; includes requirements for agriculture).

**RECOMMENDATION**

Continue periodic updates on California State Legislature bills and laws relative to pertinent bills passed and chaptered in 2009.

**ATTACHMENTS**

None.

TO: COMMITTEE MEMBERS  
FROM: DON SPAGNOLO   
DATE: AUGUST 6, 2010

**AGENDA ITEMS**  
**5**  
**AUGUST 9, 2010**

DISCUSS WATER CONSERVATION PROGRAM UPDATES

**ITEMS**

Discuss progress of elements of the Water Conservation Program.

**BACKGROUND**

The District's Water Conservation Program has several elements. Updates can be provided, as needed, to the Committee.

**RECOMMENDATION**

Discuss Water Conservation Program. Make recommendations as needed.

**ATTACHMENTS**

Item 5 (1-3): *Planting Plan* for replacement of hedging plants along the north boundary of the District office landscape.

T:\BOARD MATTERS\BOARD MEETINGS\BOARD LETTER\2009\COMMITTEES\WATER CONSERVATION COMMITTEE\08-09-2010 MEETING\08-09-2010\ITEM5.DOC

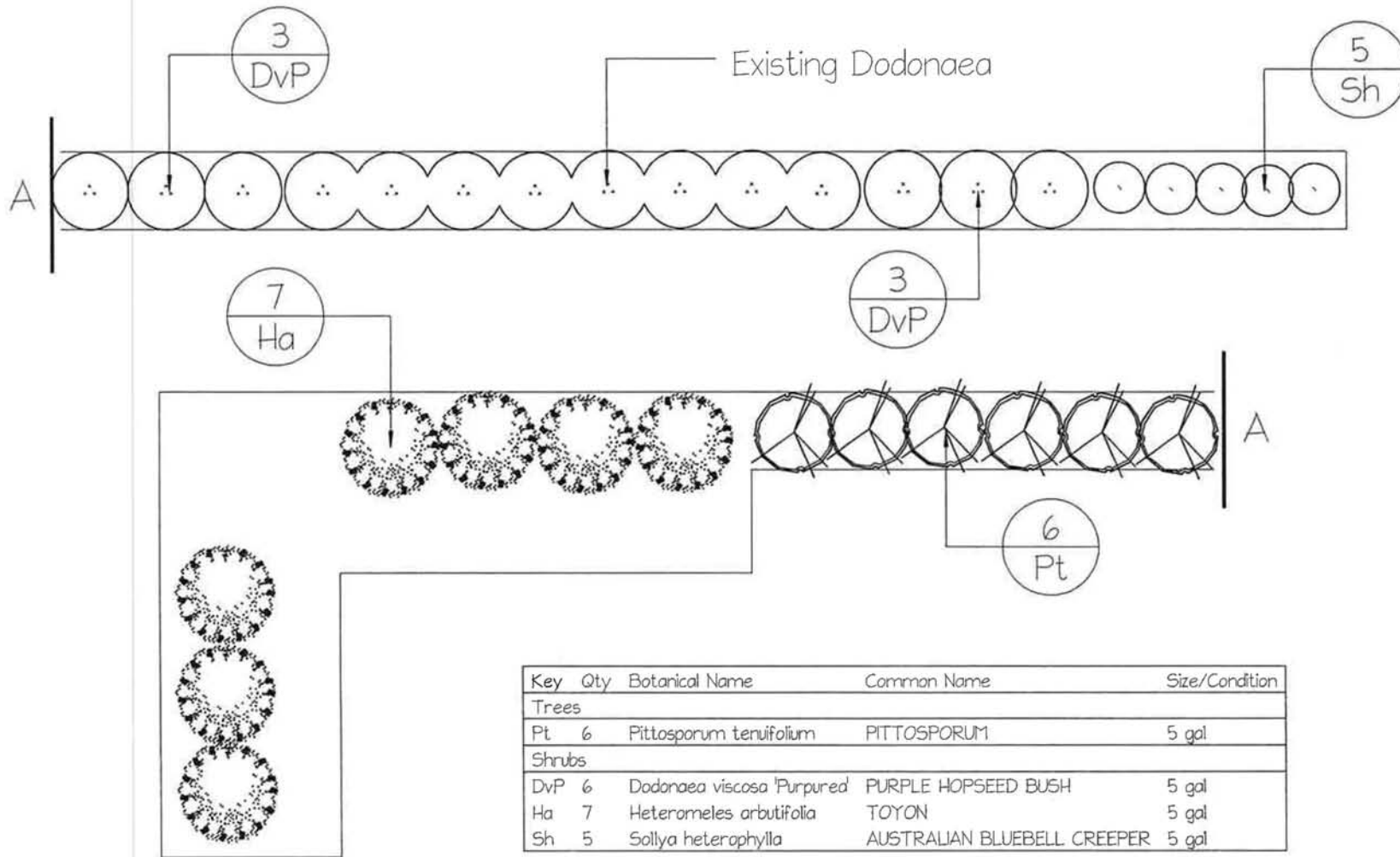

PROJECT INFO  
Nipomo CSD Parking Lot  
Nipomo, CA

PLANTING PLAN

DATE August 5, 2010

SCALE 1" = 8'-0"





*Dodonea viscosa* "Purple Hopseed Bush"



*Sollya heterophylla* "Australian Bluebell"



*Hetermeles arbutifolia* "Toyon"



*Garrya elliptica* "Silk Tassel Bush/Tree"

TO: COMMITTEE MEMBERS

FROM: DON SPAGNOLO



DATE: AUGUST 6, 2010

**AGENDA ITEMS**

**6**

**AUGUST 9, 2010**

**SET DATE AND TIME OF SUBSEQUENT MEETING**

**ITEMS**

Set date and time of subsequent Water Conservation Committee meeting.

**BACKGROUND**

Water Conservation Committee Meeting scheduling.

**RECOMMENDATION**

Schedule meeting.

**ATTACHMENTS**

None.

T:\BOARD MATTERS\BOARD MEETINGS\BOARD LETTER\2009\COMMITTEES\WATER CONSERVATION COMMITTEE\08-09-2010 MEETING\08-09-2010\ITEM6.DOC