

TO: MICHAEL LEBRUN *MSL*  
INTERIM GENERAL MANAGER

FROM: PETER SEVCIK *P.S.*  
DISTRICT ENGINEER

DATE: MAY 5, 2011

**AGENDA ITEM**  
**E-1**  
**MAY 11, 2011**

**ADOPT REVISIONS TO STANDARD SPECIFICATIONS  
FOR WATER AND SEWER SYSTEM IMPROVEMENTS**

**ITEM**

Consider adoption of revisions to Standard Specifications for Water and Sewer System Improvements [ADOPT RESOLUTION].

**BACKGROUND**

In March 2008, your Honorable Board adopted a comprehensive a re-write of the District's Standard Specifications. Several minor issues have arisen during the last several years that are not addressed clearly enough in the current Standard Specifications. In addition, staff found several changes that needed to be made based on:

- Minor inconsistencies in the District's standards
- Inconsistencies between the District's standards and San Luis Obispo County standards
- Revised California Water Works Standards
- Revised American Water Works Standards
- Cal Fire Residential Sprinkler requirements

Attached is a draft update of the Standard Specifications. Also attached is a Draft Resolution, which would rescind the old Standard Specifications and adopt the new Standard Specifications.

**FISCAL IMPACT**

Budgeted staff time and consultant time was used to prepare the update.

**RECOMMENDATION**

Staff recommends that your Honorable Board adopt the attached Resolution.

**ATTACHMENTS**

- Standard Specifications Dated May 11, 2011
- Draft Resolution 2011-XXXX Adopting Revised Standard Specifications

# **STANDARD SPECIFICATIONS FOR WATER AND SEWER SYSTEM IMPROVEMENTS**

## **Nipomo Community Services District**

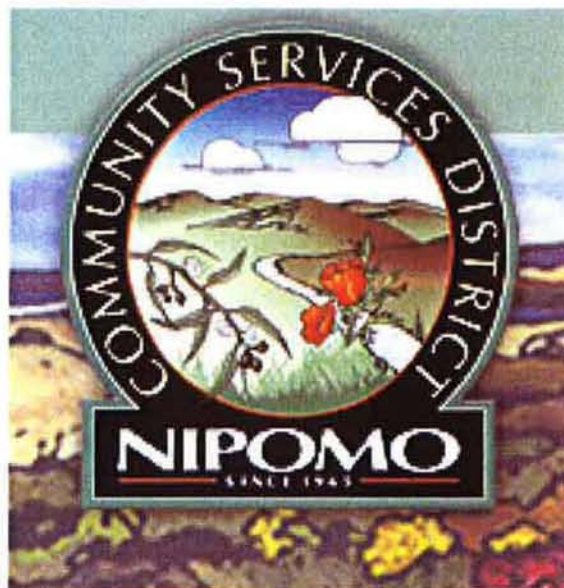

## **Revised May 2011**

# STANDARD SPECIFICATIONS FOR WATER AND SEWER SYSTEM IMPROVEMENTS

## Nipomo Community Services District

**Adopted by the Board of Directors:**

Resolution No. 2011-XXXX  
May 11, 2011

**Approved:**



Michael S. LeBrun  
Interim General Manager



**Recommended for Approval:**

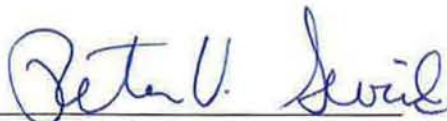

Peter V. Sevcik  
District Engineer



# Master Table of Contents

---

General Conditions & Forms .....	Page 1
Water & Sewer System Design Criteria.....	Page 13
Technical Specifications.....	Page 21
Standard Drawings.....	Page 72
Forms.....	Appendix A
Water Main Separation Requirements .....	Appendix B
Water Demand Rates and Peaking Factors .....	Appendix C
Sewer Flow Rates and Peaking Factors .....	Appendix D



# General Conditions

---

# Table of Contents

## General Conditions

<b>SECTION 1</b>	<b>DEFINITIONS, TERMS, AND ABBREVIATIONS.....</b>	<b>3</b>
1-1	DEFINITIONS .....	3
1-2	TERMS.....	4
1-3	ABBREVIATIONS.....	4
1-4	APPLICABILITY.....	5
<b>SECTION 2</b>	<b>PLAN PREPARATION AND EASEMENTS .....</b>	<b>5</b>
2-1	PRELIMINARY INVESTIGATION.....	5
2-2	PLAN PREPARATION.....	5
2-3	RECORD DRAWINGS.....	5
2-4	EASEMENTS .....	6
2-5	SECURITY (BONDING).....	6
<b>SECTION 3</b>	<b>CONSTRUCTION AND INSPECTION .....</b>	<b>7</b>
3-1	GENERAL.....	7
3-2	GOVERNING SPECIFICATIONS .....	7
3-3	EXCAVATION PLANS FOR WORKER PROTECTION.....	7
3-4	NOTICE TO PROCEED.....	8
3-5	CONNECTION TO EXISTING FACILITIES .....	8
3-6	NOTICE OF BEGINNING CONSTRUCTION .....	8
3-7	OTHER PERMITS.....	8
3-8	CONSTRUCTION WATER .....	8
3-9	INSPECTION BY THE DISTRICT .....	8
3-10	INSPECTION BY THE OWNER'S ENGINEER.....	9
<b>SECTION 4</b>	<b>CONTROL OF MATERIAL.....</b>	<b>9</b>
4-1	QUALITY OF MATERIALS.....	9
4-2	DEFECTIVE MATERIALS .....	9
4-3	STORAGE OF MATERIALS .....	9
<b>SECTION 5</b>	<b>LEGAL RELATIONS AND RESPONSIBILITIES .....</b>	<b>10</b>
5-1	OBSERVING LAWS AND ORDINANCES.....	10
5-2	PERMITS AND LICENSES .....	10
5-3	INVENTIONS, PATENTS AND COPYRIGHTS .....	10
5-4	PUBLIC CONVENIENCE AND SAFETY.....	10
5-5	RESPONSIBILITY FOR LOSS, DAMAGE OR INJURIES .....	11
5-6	OWNER'S RESPONSIBILITY FOR THE PROJECT .....	11
5-7	PRESERVATION OF PROPERTY.....	11
5-8	SAFETY .....	12
<b>SECTION 6</b>	<b>FINAL ACCEPTANCE OF THE PROJECT BY THE DISTRICT .....</b>	<b>12</b>
6-1	FINAL INSPECTION .....	12
6-2	CERTIFICATION OF THE WORK BY THE OWNER'S ENGINEER.....	12
6-3	WARRANTY .....	12

## GENERAL CONDITIONS

### SECTION 1 DEFINITIONS, TERMS, AND ABBREVIATIONS

#### 1-1 DEFINITIONS

Whenever the following terms or abbreviations occur in these specifications, the meaning shall be interpreted as follows:

**ACCEPTANCE** – That formal action by the Board accepting the Project as completed by the General Manager.

**AWWA Standard** – The latest version of the standard adopted by the American Water Works Association.

**BOARD OF DIRECTORS OR BOARD** – The Board of Directors of the Nipomo Community Services District.

**CONTRACT** – The agreement executed between the Owner and the District covering the water, sewer, and/or other system improvements to be constructed and to become a part of the District's facilities.

**CONTRACTOR** – The person, firm or corporation constructing the water, sewer, and/or other system improvements for the Owner, or the District.

**DAYS** – When used to designate a period of time, shall be in reference to consecutive calendar days.

**DISTRICT** – Nipomo Community Services District, San Luis Obispo County, California. Where the word "District" is used in a sense requiring action, such as, approving, inspecting, make a decision, etc., the "GENERAL MANAGER" shall be understood as the person having the authority to take the required action.

**DISTRICT ENGINEER** – The Engineer employed by the District to oversee design and construction of improvements.

**DISTRICT INSPECTOR** – The Inspector employed by the District to perform inspection during construction of the work undertaken by the Owner.

**GENERAL MANAGER** – The Manager of Nipomo Community Services District, the Manager's authorized representative, or other such person as may be designated by the District.

**IMPROVEMENTS OR WORK** – Facilities to be constructed by the Owner and dedicated to the District including water, sewer and other facilities; sometimes referred to as, the project, or the facilities.

**LABORATORY** – The laboratory approved by the District to test materials and work involved in the Contract.

**LEGAL ADDRESS OF OWNER** – The address shown as the Owner's in Article IX of the Contract as the place to which all notices, letters or other communications to the OWNER shall be mailed or delivered.

**NOTICE TO PROCEED** – Authorization by the District in writing allowing the Owner to begin work on the specified project.

**OWNER'S ENGINEER** – Any person or persons, firm, partnership or corporation legally authorized and licensed to practice Civil Engineering in the State of California, who prepares or submits improvement plans and specifications on behalf of the Owner. The Owner's Engineer shall also be responsible for in-

specification and certification of the work. The Owner's Engineer is sometimes referred to as the Project Engineer.

**OWNER'S INSPECTOR** – The Inspector employed by the Owner's Engineer and/or Owner to assure the improvements are constructed in accordance with the District Standards and the approved plans and specifications.

**PLANS** – The Owner's Engineer's plans, profiles, typical cross-sections, working drawings, detail drawings and supplemental drawings, or exact reproduction thereof, approved by the District, which show the locations, character, dimensions and details of the work to be done.

**PROJECT** – The improvements to be constructed pursuant to the Contract.

**RULES AND REGULATIONS** – Nipomo Community Services District General Resolutions and Ordinances adopted by the District and as amended from time to time.

**SPECIFICATIONS** – The directions, provisions and requirements of the District, pertaining to the method and manner of performing the work shown on the Plans. The Specifications include these Standard Specifications for Water and Sewer Improvements.

**STATE SPECIFICATIONS** – The Standard Specifications, State of California, Department of Transportation, latest edition.

**SUBCONTRACTOR** – A person, firm or corporation supplying labor, or labor and materials for the Project as a part of the Construction Contractor's obligation to the Owner.

**SURETY** – The party or parties who guarantee the completion of the Project or a portion of the Project, by bonds, and whose signatures are attached to the bond.

## **1-2 TERMS**

Whenever in the Specifications or upon the Plans the words directed, required, permitted, ordered, designated, prescribed or terms of like import are used, it shall be understood that the requirements, permission, order, designations, or prescription of the District is intended. Similarly, the terms approved, acceptable, satisfactory, or equal, or terms of like import, shall mean approved by, acceptable to or satisfactory to the District, unless otherwise expressly stated. The word "provide" shall be understood to mean furnish and install.

## **1-3 ABBREVIATIONS**

Wherever the following abbreviations are used, they shall have the meanings indicated:

ACI	American Concrete Institute
ASTM	American Society for Testing and Materials
AWWA	American Water Works Association
NASSCO	National Association of Sewer Service Companies
PACP	NASSCO's Pipeline Assessment and Certification Program

## **1-4 APPLICABILITY**

In those cases when, in the opinion of the District, circumstances require the design and construction of any water and/or sewer system improvements not adequately covered by these specifications, the District may set different design criteria, require use of other materials, and/or special construction techniques.

## **SECTION 2 PLAN PREPARATION AND EASEMENTS**

### **2-1 PRELIMINARY INVESTIGATION**

The Owner shall meet with the District at the earliest possible date to determine whether the property to be developed is within the District boundaries. At that time, the availability of existing water and/or sewer lines can also be reviewed. In some areas, a preliminary feasibility investigation and report may be necessary to establish that the District can serve the proposed development. All costs for such an investigation and report shall be borne solely by the Owner. Advance deposits in amounts to be determined by the District may be required.

### **2-2 PLAN PREPARATION**

The Plans must be prepared under the direct supervision of a registered civil engineer licensed to practice in the State of California. The Plans will be prepared in the latest version of AutoCAD and 4 sets on bond paper (24" x 36") shall be submitted for each review. The density of the grid on profiles (plan and profile drawings are required by the District) shall be such that the Plans shall be easily interpreted. The minimum scale shall be 1-inch equals 50 feet, with a plan to profile scale ratio of 5 to 1. Elevations shall be shown using the North American Vertical Datum of 1988 (NAVD 88) for vertical control. Any deviation from these scale requirements shall be approved by the District. The Plans shall have sufficient detail so that it can be easily determined that there will be adequate cover over pipelines and services and that where water system improvements cross other improvements, such as sewer, storm drains, etc., there will be no conflicts. Elevations for all improvements including hydrants, valve boxes, meter boxes, blow-offs, air/vacuum release valves, and manhole covers shall be shown on the plans.

All plans that propose improvements to the District Water facilities shall contain the District's Standard Water Notes (Standard Drawing W-1). All plans that propose improvements to the District Sewer facilities shall contain the District's Standard Sewer Notes (Standard Drawing S-1).

All non-standard details shall be shown on the plans. The following note is required to be shown on the plans, when standard details are shown:

THE WORK SHALL BE PERFORMED IN COMPLETE CONFORMANCE WITH THE CURRENT NCSD STANDARD SPECIFICATIONS FOR WATER AND SEWER SYSTEM IMPROVEMENTS. THE OMIS-SION OF ANY CURRENT STANDARD DETAIL DOES NOT RELIEVE THE CONTRACTOR FROM THIS REQUIREMENT.

### **2-3 RECORD DRAWINGS**

During construction of the improvements, the Owner's Engineer shall note District Approved deviations from the Plans on a set of the Plans specifically set aside for this purpose at the Project site. Any changes shall be made on the originals of the Plans with a suitable note on each sheet stating that the originals are the "Record Drawings". The record drawings shall be filed with and become the property of the District prior to Acceptance by the District of the Project. Record Drawings shall be submitted in a reproducible state on mylar sheets and in AutoCAD electronic format.



(NOTE: Two sets of "original" record drawings will be required in many cases; one set for the County and one set for the District. A CD copy shall also be provided to the District.)

**2-4 EASEMENTS**

Easements shall be avoided where a reasonable alternate solution is available as determined by the District. If an easement(s) or other right of way document is required for construction and/or maintenance of water and/or sewer improvements, the minimum width shall be 20 feet unless otherwise agreed to in writing by the District. However, there may be instances where easements of a greater width are required as determined by the District. Easements shall be granted and executed prior to District approval of the plans. The form of the grant of easement, or other right of way document to be used shall be approved by the District. The District Board shall accept the easement before it is recorded. Easements and Rights of Way shall be shown on the Plans.

**2-5 SECURITY (BONDING)**

**Security required.** Security (also referred to as "bonding") must be posted with most subdivision projects, to ensure completion of the public improvements that are required as conditions of approval. Following approval of the improvement plans, the District will review an Engineer's Estimate of the cost of construction that is to be secured. Please note that the cost estimate must be based on unit costs that would be experienced if the District were to claim the bonds and construct the improvements under public agency contracting rules. Unit costs shall be at least those shown in the current edition of the San Luis Obispo County Approved Unit Costs for Bonding Purposes table adjusted by the current Caltrans Price Index.

Once the District has approved the estimate of construction cost, the following factors must be added:

Construction cost	Contingency	Inflation	Administrative costs
<%75,000	10%	10%	40%
\$75,000 - \$200,000	10%	10%	30%
>\$200,000	10%	10%	20%

(Construction cost) + (Contingency) + (Inflation) + (Administrative costs) = **Bonding Amount**

**Items to be secured.** There are three different items to be secured during the bonding period:

Performance = 100% of the bonding amount. Once all the required public improvements have been accepted and a Guarantee Bond posted, the Performance Bond will be exonerated. Note that acceptance includes the completion of the improvements and the preparation of "as-built" plans, submittal of required reports, submittal of offer of dedication and the engineer's certification.

Payment and Materials = 50% of the bonding amount. The Payment and Materials Bond will be held for 90 days after acceptance of the improvements.

Guarantee = 10% of the bonding amount. The Guarantee Bond will be held for one year from date of completion and acceptance of improvements.

Types of security. The types of security accepted by Nipomo Community Services District are listed below. Note that all forms of security must be made payable to the Nipomo Community Services District.

Cash. Submit 100% of the bonding amount. A certified check may also be submitted in this amount. Because we pay you interest, a Taxpayer Identification Number is required with cash bonds. You will need to fill out an IRS form W-9 and return it to the District with your check. The form may be obtained at: <http://www.irs.gov/pub/irs-pdf/fw9.pdf>

Certificate of Deposit. Submit three separate certificates – 1 @ 50%, 1 @ 40%, 1 @ 10% of the bonding amount.

Letters of Credit. Submit three separate letters of credit – 1@ 100%, 1@ 50%, 1 @ 10% of the bonding amount. The Guarantee letter of credit (10%) may be submitted at the time of acceptance of improvements. Important - any Letters of Credit with expiration dates need to include an automatic extension and notice provision.

Surety Bonds. Submit two separate bonds – 1 @ 100%, 1 @ 50% of the bonding amount. The Performance bond (100%) will be reduced to 10%, to become the Guarantee bond, at the time of acceptance of improvements..

### **SECTION 3 CONSTRUCTION AND INSPECTION**

#### **3-1 GENERAL**

The Owner may be required to enter a Plan Check and Inspection Agreement and provide a deposit. Improvements shall be constructed to the ends of all streets in the subdivision. The Owner and/or Contractor shall provide all transportation, materials, equipment, labor and supplies to complete excavation, back-fill, street repairing and other work incidental to the construction of the Project

#### **3-2 GOVERNING SPECIFICATIONS**

All improvements to be dedicated to the District shall be constructed in accordance with the Standard Specifications and the Rules and Regulations of the District. The Rules and Regulations, as adopted from time to time, are hereby made a part of these specifications.

#### **3-3 EXCAVATION PLANS FOR WORKER PROTECTION**

The Owner shall submit to the District, in advance of excavation, a detailed plan showing the design of shoring, bracing, sloping, or other provisions to be made for worker protection from the hazard of caving ground during the excavation of any trench or trenches 5 feet or more in depth. The plan shall be prepared by a registered civil or structural engineer. As a part of the plan, a note shall be included certifying that the plan complies with the CAL/OSHA Construction Safety Orders, or that the registered civil or structural engineer certifies that the plan is not less effective than the shoring, bracing, sloping, or other provisions of the Safety Orders.

The detailed plan showing the design of shoring, etc., shall include surcharge loads for nearby embankments and structures, for spoil banks, and for construction equipment and other construction loadings. The plan shall indicate for all trench conditions the minimum horizontal distances from the side of the trench at its top to the near side of the surcharge loads.

Nothing contained in this article shall be construed as relieving the Owner of the full responsibility for providing shoring, bracing, sloping, or other provisions which are adequate for worker protection.

### **3-4 NOTICE TO PROCEED**

The Owner shall not commence construction until the Notice to Proceed is issued by the District. The Notice to Proceed shall not be issued until after approval by the District of the Plans and Specifications, bond and insurance forms, grant of easement(s), if any, and until after payment of the initial deposit of estimated capacity fees, if any, and the Inspection Fee Deposit.

### **3-5 CONNECTION TO EXISTING FACILITIES**

No connection shall be made to existing facilities of the District without prior approval and inspection by representatives of the District.

### **3-6 NOTICE OF BEGINNING CONSTRUCTION**

Notice shall be given to the District at least seven working days in advance of commencement of work, and a preconstruction meeting shall be scheduled at that time. Prior to commencing work, the Owner shall hold a pre-construction meeting. At a minimum, the Owner, Owner's Engineer, District Inspector, Contractor, County Inspector, and other utilities affected by the work shall attend. Prior to any excavation, the Owner shall notify all owners of existing utilities and facilities in the proposed project area, and Underground Service Alert.

### **3-7 OTHER PERMITS**

Prior to commencing construction the Owner shall secure all permits, including an encroachment permit, and all licenses, pay all charges and fees, and give all notices as necessary and required for the Project by other agencies having jurisdiction. These shall be made available to the District upon demand.

### **3-8 CONSTRUCTION WATER**

Water used for construction, testing and dust control shall be arranged for and furnished by the Owner and/or Contractor at the expense of the Owner and/or Contractor. The Owner shall comply with all regulations of the District relative to connection to fire hydrants or standpipes and secure prior written permission from the District if water from a District owned source is to be used.

### **3-9 INSPECTION BY THE DISTRICT**

All work shall be subject to inspection by the District. Owner or Owner's representative shall provide the District with a minimum of 72-hours notice prior to backfill. When requested by the District the improvements shall be left open and uncovered until the installation is inspected by the District. District inspections will occur during normal working hours. Normal working hours for the purposes of inspection are between the hours of 8:00 a.m. and 4:30 p.m. of each day except Saturdays, Sundays and District holidays.

The District shall at all times have access to the work during construction and shall be furnished with every reasonable facility for ascertaining full knowledge respecting the progress, workmanship and character of materials used and employed in the work.

The inspection of the work by District shall not relieve the Owner, the Owner's Engineer, and/or Owner's Contractor of any obligations to construct and inspect the Improvements as prescribed by the District's Specifications and Agreements. Defective work shall be made good, and unsuitable materials may be rejected notwithstanding the fact that such defective work and unsuitable materials have been previously

overlooked by the District. The installation and inspection of unsuitable improvements shall not be construed as acceptance and modification to these specifications.

The Owner shall bear the costs of District inspections.

### **3-10 Inspection by the OWNER'S Engineer**

The Owner's Engineer shall have the responsibility for performing regular inspection during the construction of all work. The Owner's Engineer shall be responsible for inspecting the work on a regular basis, and shall be present for testing of improvements. The Owner's Engineer shall be responsible for compaction testing and inspection of trench bedding and backfill. Results of compaction testing shall be made available to the District. Additional inspections may be required as determined by the District.

All Improvements, including pipe fittings, which are to be backfilled shall be inspected by the Owner's Engineer prior to backfilling, and the Owner and/or Owner's Contractor shall give due notice in advance of backfilling to the District so that the District Inspector may have opportunity to inspect the Improvements in accordance with Section 3-9.

The Owner's Engineer shall certify that the improvements have been constructed in accordance with the approved plans and specifications. Any deviations from the plans shall be pre-approved by the District Engineer in writing prior to installation of the improvements. Any work installed which is not in accordance with the approved plans shall be deemed defective and will be subject to rejection.

## **SECTION 4 CONTROL OF MATERIAL**

### **4-1 QUALITY OF MATERIALS**

All equipment, materials and supplies to be incorporated in the Project shall be new unless otherwise specified and shall conform to the requirements stated in the Plans and Specifications approved by the District.

### **4-2 DEFECTIVE MATERIALS**

All materials not conforming to the requirements of the approved Plans and Specifications shall be considered as defective and all such materials, whether in place or not, shall be rejected and shall be removed immediately from the site of the work unless otherwise permitted in writing by the District. No rejected material, the defects of which have been subsequently corrected, shall be used until approved in writing by the District. Upon failure on the part of the Owner to comply with any order of the District made under the provisions of this article, the District shall have authority to remove and replace defective material at the expense of the Owner and/or Contractor.

### **4-3 STORAGE OF MATERIALS**

All materials for use in the Project shall be stored by the Owner and/or Contractor in such a manner as to prevent damage from exposure to the elements, admixture of foreign materials, or from any other cause. The Owner and/or Contractor shall be fully responsible for any damage incurred to the materials for the Project while being stored, including damage resulting from storing of material in public right-of-way and District acquired easements. The Owner and/or Contractor shall also be fully responsible for the preservation of public and private property while storing materials for the Project.

## **SECTION 5    LEGAL RELATIONS AND RESPONSIBILITIES**

### **5-1    OBSERVING LAWS AND ORDINANCES**

The Owner and/or Contractor shall keep themselves fully informed of all laws, ordinances and regulations which in any manner affect those engaged or employed in the work or the materials used in the Project or which in any way affect the conduct of the work and of all such orders and decrees of bodies or tribunals having any jurisdiction or authority over same.

The Owner and/or Contractor shall at all times observe and comply with and shall cause all of the Owner's agents, employees, Contractor, subcontractors, and suppliers to observe and comply with all laws, ordinances, regulations, orders and decrees, and shall hold harmless, indemnify and defend the District, the District's Engineer, and their consultants, and each of their directors, officers, employees and agents from and against all claims, damages, losses, expenses, and other costs, including costs of defense and attorneys' fees, arising out of or resulting from the violation of any such law, ordinance, regulation, order or decree by the Owner, Contractor, employees, agents, subcontractors, or suppliers.

### **5-2    PERMITS AND LICENSES**

The Owner and/or Contractor shall procure all permits and licenses, pay all charges and fees, and give all notices necessary and incidental to the due and lawful prosecution of the work.

### **5-3    INVENTIONS, PATENTS AND COPYRIGHTS**

The Owner shall pay all royalties and assume all costs arising from the use of any invention, design, process, materials, equipment, product or device which is the subject of patent rights or copyrights.

The Owner and/or Contractor shall hold harmless, indemnify and defend the District, the District's Engineer, and their consultants, and each of their directors, officers, employees and agents from and against all claims, damages, losses, expenses and other costs, including costs of defense and attorney's fees, arising out of any infringement of patent rights or copyrights incident to the use in the performance of the work or resulting from the incorporation in the Project of any invention, design, process, materials, equipment, product or device and shall defend all such claims in connection with any alleged infringement of such rights.

### **5-4    PUBLIC CONVENIENCE AND SAFETY**

The Owner and/or Contractor shall so perform construction as to offer the least possible obstruction and inconvenience to the public, and the Contractor shall have under construction no greater length or amount of work than can be prosecuted properly with due regard to the rights of the public.

Convenient access to driveways, houses and buildings along the line of work shall be maintained and temporary crossings shall be provided and maintained in good condition. Not more than one crossing or intersecting street or road shall be closed at any one time.

The Owner and/or Contractor shall provide and maintain such fences, barriers, directional signs, lights and flagmen as are necessary to give adequate warning to the public at all times of any dangerous conditions to be encountered as a result of the construction work and to give directions to the public.

All construction shall be performed in compliance with the standards as established by the Occupational Health and Safety Act (OSHA) and appropriate State of California regulation.



All work in the County right-of-way shall comply with the San Luis Obispo County Public Improvement Standards for Traffic Control.

The Owner shall also bear the cost of traffic regulations lawfully exacted by the Federal Government, the State of California, or County or during the time of performing work affecting the property of said Government, State, or County.

#### **5-5 RESPONSIBILITY FOR LOSS, DAMAGE OR INJURIES**

The Owner and/or Contractor shall be responsible for all claims, demands, or liability from any cause arising out of or resulting from or in connection with the performance of the work, excepting only those as may be caused solely and exclusively by the fault or negligence of the District, the District's Engineer, or their consultants, or their directors, officers, employees and agents. Such responsibility shall extend to claims, demands, or liability for loss, damage or injuries occurring after completion of the Project as well as during the progress of the work.

#### **5-6 OWNER'S RESPONSIBILITY FOR THE PROJECT**

Until acceptance of the project, the Owner shall have the responsible charge and care of the Project and of the materials to be used therein (including materials which have been furnished by the District) and shall bear the risk of injury, loss or damage to any part thereof by the action of the elements or from any other cause, whether arising from the execution or from the non-execution of the Project.

The Owner shall rebuild, repair, restore and make good all injuries, losses or damages to any portion of the Project or the materials occasioned by any cause before its completion and acceptance and shall bear the expense thereof. Where necessary to protect the Project or materials from damage, the Owner shall bear the expense of providing suitable drainage and erecting such temporary structures as are necessary to protect the Project or materials from damage. The suspension of the work or the granting of an extension of time from any cause whatever shall not relieve the Owner of responsibility for the work and materials as herein specified.

#### **5-7 PRESERVATION OF PROPERTY**

The Owner shall exercise due care to avoid injury to existing improvements or facilities, utilities, adjacent property, and trees and shrubbery that are not to be removed.

All trees, shrubbery and landscaping that are not to be removed, and pole lines, fences, signs, survey markers and monuments, buildings and structures, conduits, pipelines under or above ground, sewer and waterlines, all highway or street facilities, and any other improvements or facilities within or adjacent to the Project shall be protected from injury or damage, and the Owner shall provide and install suitable safeguards to protect such objects from injury or damage, and the Contractor shall provide and install suitable safeguards to protect such objects from injury or damage. If such objects are injured or damaged by reason of the Owner's operation, they shall be replaced or restored at the Owner's expense to a condition as good as required by the Plans and Specifications if any such objects are a part of the work being performed.

The fact that any such pipe or other underground facility is not shown on the Plans shall not relieve the Owner of responsibility under this article.

In addition to any requirements imposed by law, the Owner shall shore up, brace, underpin and protect as may be necessary, all foundations and other parts of all existing structures adjacent to and adjoining the site of the work which are in any way affected by the excavations or other operations connected with the performance of the work. Whenever any notice is required to be given by the Owner to any adjacent or

adjoining landowner or other party before commencement of any work, such notice shall be given the Owner.

#### **5-8 SAFETY**

The Owner and/or Contractor shall be solely and completely responsible for conditions of the jobsite, including safety of all persons and property during performance of the work, and the Owner and the Contractor shall fully comply with all state, federal and other laws, rules, regulations and orders relating to safety of the public and workers.

The right of the District to conduct construction review or observation of the work will not include review or observation of the adequacy of the Owner's and/or Contractor's safety measures in, on or near the construction site.

### **SECTION 6 FINAL ACCEPTANCE OF THE PROJECT BY THE DISTRICT**

#### **6-1 FINAL INSPECTION**

Final Inspection shall be conducted in the presence of the District upon reasonable notice.

#### **6-2 CERTIFICATION OF THE WORK BY THE OWNER'S ENGINEER**

The work shall be subject to final inspection and testing under the supervision and in the presence of Owner's Engineer. If, in the Owner's Engineer's judgment, the work has been duly inspected during construction and has satisfactorily passes final inspection and testing and is ready for acceptance the Owner's Engineer shall certify the same to the Board on a form approved by the District.

#### **6-3 WARRANTY**

All work shall be warranted by Owner against defective workmanship and materials for a period of 1 year from the date the work is accepted by the District. Owner, at Owner's expense shall replace or repair any such defective work in a manner satisfactory to the Owner's Engineer and the District,

# **Water & Sewer System Design Criteria**

---

## **WATER SYSTEM DESIGN CRITERIA**

### **CONFORMANCE WITH APPLICABLE STANDARDS**

All work shall be performed in accordance with the Nipomo CSD Standards and Specifications for Water and Sewer System Improvements, the California Waterworks Standards, and the latest amended Standards of the American Water Works Association (AWWA), hereinafter referred to as District Standards, Waterworks Standards, and AWWA Standards. In case of conflict between the District Standards, Waterworks Standards, or AWWA Standards, the more restrictive Standard shall apply.

### **WATER DEMANDS**

The water systems shall be designed to meet the Average Day Demand (ADD), Maximum Day Demand (MDD), and Peak Hour Demand (PHD) estimated using the information provided in Appendix C. Water velocities in mains shall not exceed 5 feet per second under all system demand conditions, including fire flow demand during peak hour demand.

#### Fire Flow

The California Department of Forestry and Fire Protection (Cal Fire)/ San Luis Obispo County Fire Department shall determine the fire flow requirements.

### **PIPELINE SYSTEM DESIGN CRITERIA**

The water distribution system shall be designed to satisfy the requirements of the California Waterworks Standards (Title 22 California Code of Regulations, Division 4 Environmental Health, Chapter 16, Sections 64551 et seq.). The distribution system shall be able to provide a minimum operating pressure in the water main at the user service line connection throughout the distribution system of not less than 20 pounds per square inch at all times, and not less than 40 pounds per square inch at all times excluding fire flow.

Design of PVC pressurized water pipelines shall take into consideration the maximum anticipated working pressure, maximum anticipated occasional surge pressure, and recurring surge pressures, as defined in AWWA C900. In all cases the maximum anticipated working pressure cannot exceed the pipe's pressure class times the temperature coefficient, occasional surge pressure capacity cannot exceed the short-term pressure rating times the temperature coefficient, and recurring surge pressure capacity cannot exceed the pipe's pressure class times the temperature coefficient.

For PVC pipelines, the type of pipe embedment should be selected so as to prevent a vertical cross-section long-term ring deflection of more than 7.5 percent as estimated using the design information provided in AWWA Manual M23.

The minimum pipe size for water mains shall be 8-inches in diameter. All line sizing shall be based on maximum day demand plus fire flow demand or peak hour demand, whichever is greater. Pipeline pressure losses will be calculated using the Hazen-Williams formula with  $C=130$ .

Minimum cover over the top of pipe shall be three feet below finish grade. The District may require more than this minimum cover if, in the opinion of the District, three feet is insufficient.

As a general rule, there shall be three valves on tees and four valves on crosses. On long blocks, intermediate valves should be installed so that not more than 500 feet of line will have to be shut off at any one time. Valves shall be joined to fittings by flanges. When water mains are in easements outside traveled streets, a valve shall be located at each end of the easement. The final determination of the number of valves and their locations shall be approved by the District.

Combination air and vacuum release valves shall be installed at all high points in a line and in areas of potential negative pressure. The inlet to each valve shall be provided with a gate valve or corporation stop to provide a positive closure between the main pipeline and the air and vacuum release valve. The air and vacuum release valve vent shall be installed above ground in such a manner as to preclude backflow (see Standard Detail W-15), and shall be installed outside of the "clear zone" as defined in SLO County Standards for Public Works Improvements.

All dead ends on new mains shall be closed with plugs or caps that are suitably restrained to prevent blowing off under test pressure. If a blowoff valve precedes the plug or cap, it too shall be restrained against blowing off. All dead ends shall be equipped with suitable blowoff or venting devices.

Dead-end water mains can present a public-health hazard. California Waterworks Standards require the construction of blow-offs on dead-end mains, and also require periodic flushing of dead-end mains, thereby increasing system operating costs. Therefore, the District requires that water system improvements shall have at least two connections to waterlines in different streets to form a looped water system. Non-looped systems will be permitted only with the written permission of the District.

Water pipelines shall be constructed of PVC pipe or, with the District's approval, ductile iron pipe. Fittings shall be ductile iron conforming to AWWA C-100 and cement mortar lined per AWWA C-104.

The water distribution system shall not use any chemical, material, lubricant, or product in the production, treatment or distribution of drinking water that will result in its contact with the drinking water including process media (carbon, sand), protective materials (coatings, linings, liners), joining and sealing materials (solvent cements, welding materials, gaskets, lubricating oils), pipes and related products (pipes, tanks, fittings), and mechanical devices used in treatment/transmission/distribution systems (valves, chlorinators, separation membranes) that has not been tested and certified as meeting the specifications of NSF International/American National Standard Institute (NSF/ANSI) 61-2005 / Addendum 1.0-2005 (Drinking Water System Components—Health Effects), which is hereby incorporated by reference. This requirement shall be met under testing conducted by a product certification organization accredited for this purpose by the American National Standards Institute.

One water service per parcel shall be provided and except for connections serving a single-family residence, a separate service connection with backflow prevention device shall be provided to each parcel of property for landscape irrigation per District Ordinance.

## **FIRE HYDRANTS**

Hydrants shall conform to AWWA C-503 (wet barrel) with frangible section near ground, with two 2-1/2-inch and one 4-inch national standard threaded connections, and be painted safety yellow. Fire hydrants shall be James Jones 4060C or AVK Series 2490. Bury for hydrant shall conform to AWWA standard specifications C-503, height shall be 36-inches. Bury to be coated with coal tar enamel or coal tar epoxy (see Standard Detail W-6). Cal Fire has final approval on fire hydrant installations, Owner to coordinate with Cal Fire.

The system shall be provided with valves and hydrants so that no point on any lot at the street right-of-way shall be more than one and one-half times the maximum hydrant spacing from a working hydrant as a result of any single break or shutdown for repairs, except where impractical as determined by Cal Fire.

A hydrant shall be placed at each intersection except where this would provide excessive hydrant coverage as determined by Cal Fire. Fire hydrant spacing shall be computed separately for each side of roadways with a right-of-way greater than 60 feet.

In locations where no curb is installed, hydrants shall be installed outside of the "clear zone" as defined in SLO County Standards for Public Works Improvements.

Bollards shall be installed where considered necessary by Cal Fire to protect fire hydrants. Fire hydrant bollards/barricades shall not obstruct the outlets and shall be consistent with Standard Detail W-6.



## **CONNECTION TO FIRE SPRINKLER SYSTEMS**

Except as provided below, any connection between a building's fire sprinkler system and the District's mains shall be via a dedicated fire sprinkler connection (one per parcel) and shall be protected from backflow in accordance with the District Standards (refer to Technical Specification for Connections to Domestic Water Systems).

Any connection between a residential single-family or residential-duplex fire sprinkler system shall be via a fire sprinkler connection installed immediately downstream of the meter, shall be protected from backflow in accordance with the District Standards (refer to Technical Specification for Water Services for Combined Residential and Fire Sprinkler Systems), shall conform to the requirements of, and shall be approved by, San Luis Obispo County and Cal Fire.

## **SEPARATION BETWEEN WATER SYSTEM COMPONENTS AND OTHER UTILITIES**

Fire hydrants, meter boxes, and blowoffs shall be located no closer than 5 feet from any beginning of curb return, driveway, or other utility.

## **SEPARATION OF WATER MAINS AND SANITARY SEWERS**

All crossings of water mains and sanitary sewers shall conform to the separation requirements of the California Waterworks Standards. (Section 64572, Title 22 CCR, included in these standards in Appendix B.) If an exemption from these separation requirements is needed, the designer should coordinate the request for exemption with the District.

## **SAMPLING STATIONS**

Sampling stations may be required. The number and location of sampling stations shall be as directed by the District. Coordinate the location of the sampling station(s) with the District prior to approval of construction plans.

## **POTABLE WATER BOOSTER STATIONS AND WELLS**

Design requirements for potable water booster stations and wells will vary from project to project depending on the size and nature of the facilities. All facilities shall be equipped and capable of interfacing with the District's existing SCADA system. Final requirements for the SCADA system shall be determined in coordination with the District during the design phase. Typical minimum requirements are listed below:

1. Inlet/suction pressure and/or well level
2. Flow Rate
3. Pump Status (on/off/hand)
4. Alarms: seal failure, high temp, phase, circuit trip, high pressure, low pressure, lag pump call
5. Run time in hours for each pump
6. Amperage draw
7. Magnetic flow meter with a flow totalizer and rate of flow in gallons per minute.

Projects that anticipate the need for these facilities should initiate discussions with the District early in the design phase to determine the requirements for each project individually.

## **SEWER SYSTEM**

### **DESIGN CRITERIA**

#### **ACCEPTABLE FLOWS**

The District shall accept flows from the following plumbing fixtures, unless unusual circumstances prevent the District from doing so:

Toilets, urinals, bidets, sinks for domestic faucets, showers, bathtubs, connections for dishwashers, drinking fountains, domestic washing machines and garbage disposals.

Flows which are not acceptable to the District are flows other than sewage, and include, but are not limited to, any and all liquid or processing, commercial, or institutional operation of whatever nature. Plumbing fixtures or sources hereafter set forth shall not be discharged into the District's sewer system without specific written permission from the General Manager. District Ordinances list additional prohibited waste flows.

All piping from commercial and industrial processing to the sewers.

All floor or stall drains, other than domestic showers.

Swimming pools, ponds, etc., which empty into the sewer system.

Establishments included under the above requirements include, but are not limited to:

Gas stations, car washes, garages, laundromats, etc.

Restaurants, hotels, motels, shopping areas, breweries, and microbreweries

The District may require traps, interceptors, pretreatment or other devices on all outlets which may discharge grease, oil, sand or waste material of any kind of a composition or quality deemed harmful by the District per District Ordinance.

#### **PIPELINE SYSTEM DESIGN**

Design flows shall be based on the information in Appendix D.

Pipeline design shall be based on peak flows and on Manning's formula. Use a coefficient of "n" = 0.011 for plastic pipe and "n" = 0.013 for all other pipe.

Design peak flows in pipelines 12 inches in diameter and smaller shall be limited to an approximate liquid depth to pipe diameter ratio of 0.50.

Whenever a change in the size of the pipe, or an angle of 20 degrees or greater in alignment occurs, the flowline of the pipe flowing into the manhole shall be a minimum of 0.17 foot above the flowline of the pipe flowing from the manhole, or an amount necessary to match the inside crowns of the pipe, whichever is greater.

Minimum pipeline diameter shall be 8 inches.

Minimum pipeline grades:

Pipe Diameter (inch)	Minimum Slope (ft/ft)
8	0.0035
10	0.0025
12	0.0020
15	0.0015
18	0.0012
21	0.0010

As a general rule, sewers shall run in a straight line between manholes. All sewer alignments shall be approved by the District. Minimum pipeline grades are discouraged and must be preapproved in writing by the District and will only be approved in the District Engineer's discretion upon a finding of physical site constraints.

Minimum depth from finish street grade to top of sewer main pipe shall be six (6) feet. All sanitary sewers and appurtenant structures shall be a minimum of five (5) feet from the roadway center line. In no case shall a sanitary sewer line be located closer than two (2) feet from an existing or proposed gutter lip.

The entire sanitary system shall be located as mentioned above and shall be designed to clear all other existing or proposed utilities by a minimum of twelve (12) inches. Special structures, such as pump stations and pressure lines, etc. shall be subject to the approval of the District.

Sewer manholes are required at:

- Changes of direction of sewers.
- Changes in slope of sewers.
- Junctions of sewers.
- Junction of sewer and lateral if lateral is same size as sewer.
- Termination of sewer with a run greater than 100-ft.
- Change of pipe size in sewers.
- Other locations specified by the District.
- Maximum manhole spacing shall be 400 feet.

Whenever the vertical distance between the inverts of sewer line connections of a manhole exceeds thirty (30) inches, a standard Drop Manhole shall be constructed with the District's Approval. Drop manholes are discouraged and must be preapproved in writing by the District and will only be approved in the District Engineer's discretion upon a finding of physical site constraints.

Allowable head losses in manholes:

Straight run through manholes based on 0.20 foot loss.

Whenever a change in the size of the pipe, or an angle of 20 degrees or greater in alignment occurs, the flowline of the pipe flowing into the manhole shall be a minimum of 0.17 foot above

the flowline of the pipe flowing from the manhole, or an amount necessary to match the inside crowns of the pipe, whichever is greater.

No change of flow direction within a manhole shall exceed 90 degrees.

The invert elevation(s) at the projection of the inside wall of the manhole "IN" and the direction(s), N, S, E, or W, and invert elevation "OUT" and the direction shall be shown on the plans. Should a pipeline be joining a sewer of larger diameter, the smaller pipe shall have its crown elevation equal to or higher than the crown elevation of the larger sewer.

Manholes shall have the flow direction of the inlet(s) and outlet inscribed into their concrete collars.

There will be no shared sewer laterals; all connections to the sewer system shall be separate and independent per District Ordinance.

Connection of laterals to the sewer main at a manhole is only allowed when (a) the manhole is a terminal manhole at the end of a cul-de-sac, (b) no more than three (3) laterals are installed, (c) all of the laterals are installed to the property line(s), and (d) cleanouts are installed on the unconnected laterals at the property line(s).

### **WATER AND SEWER MAIN SEPARATION REQUIREMENTS**

All crossings of water mains and sanitary sewers shall conform to the requirements of the California Waterworks Standards. (Section 64572, Title 22 CCR, included in these standards in Appendix B.)

### **SEWAGE LIFT STATIONS**

If the Project Engineer determines, and the District agrees, that a lift station is required for a project, the lift station shall meet the following minimum design criteria, and shall be subject to preapproval by the District. The District discourages construction of new sewage lift stations. Lift stations will only be allowed under certain specific circumstances. The items discussed in this section and depicted in the drawing are minimum requirements; the District may have additional requirements depending on the specific application.

Each lift station shall be located outside of roadway right-of-ways. Each lift station shall be located on a separate lot dedicated to the District for this purpose.

Each pump shall be a submersible raw sewage pump designed to operate in a wet well under submerged conditions and shall be of the non-clog, single-suction, centrifugal type and shall be suitable for pumping unscreened raw sewage. The District standard raw sewage pump shall be manufactured by ITT Flygt, or approved equivalent.

Capacity: Pumps shall be capable of delivering the average daily flow in an efficient and economical manner. The pump(s) should be designed to operate between 70% and 120% of the best efficiency point. The lift station shall be capable of delivering the peak hour demand with redundancy.

Motors: The electric motor shall be of a high efficiency design and shall be non-overloading throughout the pump operating range.

Level Sensing: The lift station shall be controlled by a submersible level transducer Wika LS 10 level transmitter with Level Guard or equivalent. High and low water level back up shall be provided by float US Filter B100 or equivalent.

Monitoring: The lift station shall be equipped and capable of interfacing with the District's existing SCADA system, and shall monitor at a minimum the following items:

1. Wet Well Level
2. Flow Rate
3. Pump Status (on/off/hand)
4. Alarms: seal failure, high temp, phase, circuit trip, high water level, low water level, lag pump call
5. Run time in hours for each pump
6. Amperage draw
7. Magnetic flow meter with a flow totalizer and rate of flow in gallons per minute.



# Technical Specifications

---

# Table of Contents

---

## Technical Specifications

TECHNICAL SPECIFICATIONS FOR INSPECTION OF WORK.....	23
TECHNICAL SPECIFICATIONS FOR EARTHWORK.....	24
TECHNICAL SPECIFICATIONS FOR DUCTILE IRON WATER PIPE .....	32
TECHNICAL SPECIFICATIONS FOR POLYVINYL CHLORIDE WATER PIPE .....	35
TECHNICAL SPECIFICATIONS FOR RESILIENT SEAT GATE VALVES .....	38
TECHNICAL SPECIFICATIONS FOR PLASTIC FILM WRAP OF VALVES, FLANGES AND OTHER FITTINGS .....	40
TECHNICAL SPECIFICATIONS FOR WATER SERVICES .....	42
TECHNICAL SPECIFICATIONS FOR WATER SERVICES FOR COMBINED RESIDENTIAL AND FIRE SPRINKLER SYSTEMS.....	44
TECHNICAL SPECIFICATIONS FOR CONNECTIONS TO DOMESTIC WATER SYSTEM .....	46
TECHNICAL SPECIFICATIONS FOR TESTING AND DISINFECTION OF WATER PIPE .....	48
TECHNICAL SPECIFICATIONS FOR POLYVINYL CHLORIDE SEWER PIPE AND FITTINGS.....	51
TECHNICAL SPECIFICATIONS FOR CONNECTIONS TO EXISTING SEWER PIPE .....	54
TECHNICAL SPECIFICATIONS FOR SEWER LATERALS .....	55
TECHNICAL SPECIFICATIONS FOR CHEMICAL-RESISTANT COATINGS FOR MANHOLES .....	57
TECHNICAL SPECIFICATIONS FOR TESTING OF PVC SEWER PIPE .....	59
TECHNICAL SPECIFICATIONS FOR TRAFFIC REGULATION .....	65
TECHNICAL SPECIFICATIONS FOR CONCRETE CONSTRUCTION.....	67
TECHNICAL SPECIFICATIONS FOR REMOVAL AND RESURFACING OF STREET PAVEMENT AND SURFACES.....	68
TECHNICAL SPECIFICATIONS FOR USE OF COMPLETED FACILITIES .....	70
TECHNICAL SPECIFICATIONS FOR CLEAN-UP .....	71

**TECHNICAL SPECIFICATIONS  
FOR  
INSPECTION OF WORK**

All work shall be subject to inspection per Sections 3-9 and 3-10 of the General Conditions and the General Conditions as a whole.

The District and Owner's Engineer shall at all times have access to the work during construction and shall be furnished with every reasonable facility for ascertaining full knowledge respecting the progress, workmanship and character of materials used and employed in the work.

The Owner shall submit a schedule to the District and Owner's Engineer outlining the proposed construction operation including the hours of work. If any changes in the project schedule or hours of work are made, the Owner shall give at least two working days written notice to the District and Owner's Engineer so that proper inspection may be provided.

The inspection of the work shall not relieve the Owner of any of his obligations to complete the work as prescribed by the District Specifications and Approved Plans. Defective work shall be made good and unsuitable materials may be rejected notwithstanding the fact that such defective work and unsuitable materials have been previously overlooked by the District and/or Project Engineer.

The District shall have the authority to suspend the work wholly or in part for such time as it may deem necessary due to the failure to perform any provisions of District Specifications. The work shall be resumed when methods or defective work are corrected as ordered or approved in writing by the District.

--END OF SECTION--

**TECHNICAL SPECIFICATIONS  
FOR  
EARTHWORK**

**A GENERAL DESCRIPTION**

Earthwork shall consist of performing operations necessary to complete all excavation, preparation of subgrade, ditching, structural excavation, trenching, backfill compacting, sloping, trimming the subgrade, and finish grading; as shown on the Plans or contained in the Specifications. The Contractor shall furnish all labor, material, tools and equipment necessary for earthwork operations and perform all incidental work thereto as required.

Earthwork shall include all clearing and grubbing, removal and disposal of paving, removal of water, excavation of all classes of earth and rock regardless of character and subsurface conditions and disposal of all excess excavation.

**A-1 SCOPE OF WORK**

The work includes furnishing all services, labor, materials, equipment, and perform all operations in connection with all earthwork necessary for the construction of the improvements as indicated on the Plans and in the Specifications. Excavation shall include the removal of water and all material of whatever nature and shall include clearing of sites for construction.

**A-2 EARTHWORK IN STATE AND COUNTY RIGHTS-OF-WAY**

Earthwork within the rights-of-way of the State of California, Department of Transportation and the County Public Works Department shall be performed in accordance with requirements and provisions of the permits issued by those agencies for the construction within their respective rights-of-way. Where there is a conflict between the District's Specifications and those of the State or County, the more stringent requirements and provisions shall take precedence.

**A-3 SAFETY PRECAUTIONS**

All excavations shall be performed, protected and supported as required for safety and in the manner set forth in the operating rules, orders and regulations prescribed by the Division of Industrial Safety of the State of California. Barriers shall be placed at each end of all excavations and at such places as may be necessary along excavations to warn all pedestrian and vehicular traffic of such excavations.

**A-4 BRACING EXCAVATIONS**

All excavations shall be properly supported in the manner prescribed by the rules, orders and regulations of the Division of Industrial Safety of the State of California. Excavations shall be so braced, sheeted and supported that they will be safe and the ground alongside the excavation will not slide or settle, and all existing improvements of any kind, either on public or private property, will be fully protected from damage. If any damage does result to

such improvements, the Contractor, at his own expense, shall make the necessary repairs or reconstruction required as directed by the District.

Excavations shall be so braced or sheeted so as to provide conditions under which workmen may work safely and efficiently at all times. The sheetings, shoring and bracing shall be arranged so as to not place any stress on portions of the completed work until the general construction thereof has proceeded far enough to provide ample strength. Any damage to structures occurring through settlements, water or earth pressures, slides, caves or other causes due to failure or lack of sheeting or bracing or improper bracing or through negligence or fault of the Contractor in any other manner, shall be repaired by the Contractor at his own expense.

Where timber sheeting extends below the invert of the pipe, it shall be cut off at the top of the pipe and the upper portion removed without harming the support conditions. This requirement will not be necessary where steel sheeting is used for shoring below the invert of the pipe.

Care shall be exercised in the drawing or removing of sheeting, shoring, bracing and timbering to prevent the caving or collapsing of the excavation faces which are being supported.

**A-5 OPEN EXCAVATIONS AND STOCKPILING**

Open excavations and stockpiling shall be constructed in a manner to prevent water running into excavations. Obstruction of surface drainage shall be avoided and means shall be provided whereby storm and wastewater can flow uninterruptedly in existing or established flowage courses, other surface drains or temporary drains. Material for backfill or for protection of excavation in public roads from surface drainage shall be neatly placed and kept shaped so as to cause the least possible interference with public travel. Free access must be provided to all fire hydrants, water valves, meters, private drives, roads or existing access routes.

**A-6 SAND**

1/2" minus sand is to be used for pipe bedding or pipe zone; it shall be free from foreign materials such as rocks, sticks, vegetation, etc., and shall meet the following gradation:

Sieve Size	Percentage Passing (By Weight)
3/8-inch	100
No. 4	75 – 100
No. 30	12 – 50
No. 100	5 – 20
No. 200	0 - 10

**A-7 AGGREGATE FOR PIPE BEDDING FOUNDATION**

If aggregate is required for pipe bedding foundation, it shall be No. 67 crushed aggregate as defined by ASTM D 448 and shall be free from foreign and organic matter.

Gradation – ASTM D 448 (No. 67)

<b>Sieve Size</b>	<b>Percentage Passing (By Weight)</b>
1 inch	100
3/4-inch	90 – 100
3/8 inch	20 – 55
No. 4	0 – 10
No. 8	0 - 5

If aggregate is required for pipe bedding foundation, a layer of geotextile fabric shall be installed to provide separation between the pipe bedding foundation and surrounding materials. The geotextile material shall be polypropylene, needle-punched, non-woven geotextile, Mirafi S600, Geotex NW-601 or equal.

**A-8 OBSTRUCTIONS**

All underground improvements shall be preserved and protected. Where it is necessary to remove and replace or to relocate such improvements in order to prosecute the work, they shall be removed, maintained in operation, and permanently replaced as directed by the owner of the discovered obstruction or as directed by the District.

**A-9 COMPACTION TESTS**

Compaction tests will be made by the testing laboratory designated by the Owner's Engineer. The number of tests, and their location and depth, shall be determined by the Owner's Engineer after consulting with the District. Relative compaction specified herein shall be a percentage of the maximum dry density as determined by ASTM D1557 (5 layer only). Compaction tests shall be taken in accordance with D-1556 or as approved by the District.

Backfill of excavations within the rights-of-way of County streets and State highways shall be performed in accordance with the requirements and to the satisfaction of the County Public Works Department or the State Division of Highways. Where a conflict exists between the District's requirements and those of either the County or the State, the more stringent requirement shall apply.

The costs of compaction testing shall be borne by the owner.



#### **A-10 CORRECTION OF FAULTY GRADES**

Where excavation is inadvertently carried below subgrade and/or foundation elevations, suitable provision shall be made for adjustment of the subgrade. The subgrade or foundation shall be restored to a condition similar to the condition existing prior to the over-excavation and by means acceptable to the District.

#### **A-11 CLEARING AND GRUBBING**

The Contractor shall perform all required clearing and grubbing and the disposal of all trees, brush, roots and other perishable and objectionable materials.

The ground surface of all areas where material is to be excavated or where embankments, stockpiles, fills or structures are to be placed, shall be cleared of all vegetation and rubbish, and all brush, roots, and tree roots shall be grubbed and removed from such areas. All cleared and grubbed areas shall be maintained free from vegetable growth.

Organic material from clearing and grubbing operations will not be incorporated in pipe backfill.

#### **A-12 BLASTING AND EXPLOSIVES**

Written permission of the District shall be obtained from the General Manager prior to any blasting or use of explosives. Explosives, if used, shall be of such quantity and power and shall be used in such locations so as to minimize opening of seams and disturbing of the material outside the prescribed limits of excavation. As excavation approaches its final limits, the depths of holes for blasting and the quantity of explosives used for each hole shall be reduced so that the underlying or adjacent material will be disturbed or shattered as little as possible.

Extreme care shall be exercised when blasting in the vicinity of existing structures, utilities or construction facilities of others.

All blasting shall be performed in conformance with the provisions of the Construction Safety Orders of the California Department of Industrial Safety, California Administrative Code, Article 5, Title 8.

#### **A-13 DEWATERING**

There shall be provided and maintained at all times during construction ample means and devices with which to promptly remove and properly dispose of all water from any source entering the excavations or other parts of the work. Dewatering shall be accomplished by methods which will ensure a dry excavation and preservation of the final lines and grades of the bottoms of excavations. Said methods may include well points, sump pumps, suitable rock or gravel placed below the required bedding for drainage and pumping purposes, temporary pipelines and other means, all subject to the approval of the District.

Dewatering for structures and pipelines shall commence when groundwater is first encountered and shall be continuous until such times as water can be allowed to rise in accordance with the provisions of this section. No concrete footings or floors shall be laid in water nor shall water be allowed to rise over them until the concrete or mortar has set at least eight hours. Water shall not be allowed to rise unequally against walls for a period of 28 days.

The water from the work shall be disposed of in a suitable manner without damage to adjacent property. No water shall be drained into work built or under construction without prior consent of the District. Water shall be disposed of in such a manner as not to be a menace to the public health.

## **B PIPELINE AND TRENCH EARTHWORK**

### **B-1 GENERAL**

Work in connection with pipeline and trench earthwork shall include but not be limited to any or all of the following described operations: clearing; excavation of all classes and of whatever substance encountered; backfilling; fine grading; preparation for right-of-way; subgrade for pipe and structures; and paving and performing any other similar, incidental, or appurtenant earthwork operation which may be necessary to properly complete the work indicated.

### **B-2 EXCAVATION FOR PIPE TRENCHES**

Trenches for pipelines shall be excavated to the lines and grades shown on the Plans, as provided in the Specifications, and as approved by the District.

### **B-3 TRENCH WIDTH**

The overall trench width shall not be more than 16 inches nor less than 12 inches wider than the largest outside diameter of the pipe to be laid therein, measured at a point 12 inches above the top of the pipe. Excavating and retrenching shall be true to line so that a clear space of not more than 8 inches or less than 6 inches in width is provided on each side of the largest outside diameter of the pipe in place. For the purpose of this article, the largest outside diameter shall be the outside diameter of the bell, on bell and spigot pipe, and outside diameter of coupling for sleeve coupling pipe.

Where the trench width, measured at a point 6 inches above the top of the bell or sleeve of the pipe is wider than the maximum set forth above, the trench area around the pipe shall be reworked to restore a trench condition and provide load factor acceptable to the District. The reworking may result in one or more of the following operations, subject to the approval of the District: (1) Shaping the bottom of the trench to fit the pipe; (2) Placing sand around the pipe and to a point 6 inches above the top of the pipe; (3) Lowering the grade of the pipe until the trench

condition can be met; (4) Installing a concrete cradle for the pipe; and (5) Providing concrete encasement for the pipe to a point 3 inches above the top of the pipe.

#### **B-4 LIMIT OF EXCAVATION**

Trench excavation shall proceed in advance of pipe installation only so far as can be backfilled the same day. Except by special permission of the District, the maximum length of open trench shall not exceed 600 feet in the aggregate at any one location including excavation, construction, pipe laying and backfilling. In addition, at locations where access may be somewhat limited, requiring rerouting of traffic unnecessarily, the District may reduce the maximum length of open trench permitted.

#### **B-5 SUBGRADE FOR PIPE BEDDING**

The trench bottom shall be graded to provide a smooth, firm foundation at every point throughout the length of the pipe to provide a suitable bedding for the pipe.

The trench shall be excavated to the established grade line of the outside bottom of the pipe. The bottom of the trench shall then be scarified to a minimum depth of 6 inches below the bottom of the pipe and uniformly graded to produce a firm but yielding subgrade which will provide uniform support of the pipe along the full length of each section. The bedding material so prepared throughout a minimum depth of 6 inches shall meet the requirements of Section A-6 of these specifications.

If it becomes necessary to excavate below the established grade line in order to remove boulders or other interfering objects, the voids shall be filled with material meeting Section A-6 requirements densified in the manner specified for bedding materials.

Where excavation is in rock, hardpan, shale, or other similar hard and unyielding materials, the trench shall be excavated to a depth at least 6 inches below the established grade line of the outside bottom of the pipe and filled with material as specified in Section A-6 to grade line. The subgrade shall then be completed as previously stated. The material so placed shall be compacted to 90% relative compaction.

When excavation is in soft, unstable or excessively wet material which is unsuitable as a foundation for the pipe, such material shall be removed below the normal trench bottom to a minimum depth of one (1) foot, or as directed by the District and replaced with aggregate (Section A-7) compacted to 95% relative compaction and fully encased in separation geotextile fabric to provide a suitable foundation. The bedding material shall then be completed to the underside of the pipe using material that meets the requirements of Section A-6 of these specifications.

If the trench passes over a previous excavation, such as a sewer, the trench bottom shall be sufficiently compacted to provide support equal to that of the native soil or conform to other regulatory requirements in a manner that will prevent damage to the existing installation.

At each joint in the pipe, the bottom of the trench shall be recessed in such a manner as to relieve the bell of the pipe or the pipe coupling of all load and to ensure continuous bearing along the pipe barrel upon the bedding material.

#### **B-6 TRENCH BACKFILL**

All trenches shall be backfilled after pipe, fittings and appurtenances have been installed. A 2-inch layer of sand shall be placed above pipe, fittings, and appurtenances before backfilling commences. Whenever a relative compaction requirement value is specified, it shall be a percentage of the maximum density as determined hereafter. Optimum moisture content and maximum density shall be determined in accordance with ASTM D 1557 and density of soil in place shall be determined using the methods approved by the District.

All wood and waste material shall be removed from excavation preparatory to backfilling. Backfill material shall be approved in all cases by the District and shall be free of trash, wood, large rock, or other objectionable debris. Backfilling shall include the refilling and compaction of the fill in trenches of excavations up to the subgrade of the street or to the existing ground surface.

#### **B-7 BACKFILL PROCEDURE IN PIPE ZONE**

Subsequent backfill in the pipe zone shall consist of placing material as required in Section A-6 of these specifications simultaneously on each side of the pipe for the full width of the trench and compacting said material to a relative compaction of 90% within the limits of the pipe zone. The pipe zone begins at the bottom of the pipe barrel and extends to a horizontal plane 12 inches above the top of the outside diameter of the pipe.

The pipe shall be carefully bedded during initial pipe zone backfill operations by hand placing and compacting clean imported sand as provided herein, slicing with a shovel and tamping or "walking in" the material under the lower sector of the pipe from the pipe foundation and/or subgrade to the springline of the pipe to produce firm support for the full length of the barrel with full bearing on said bottom segment of the pipe equal to a minimum of 1/2 of the outside diameter of the barrel or 12-inches, whichever is greater.

The pipe bedding, using clean imported sand, shall be compacted by approved methods to a relative compaction of 90%. The pipe bedding backfill shall be brought to optimum moisture content and shall be placed in layers not exceeding 6 inches in thickness and each layer shall be solidly tamped with the proper tools so as not to injure, damage or disturb the pipe. Backfilling shall be carried on simultaneously on each side of the pipe to assure

proper protection of the pipe. Water settling for compaction may be approved by the District in the event the foundation and bedding materials are sufficiently granular and sandy in nature that the required compaction will be obtained.

For water and sewer, three-inch (3") wide polyethylene non-detectable tape marked and color coded per the design standards shall be buried in the trench 12-inches above all pipes and laterals to alert workers to the presence of the pipe and/or tracer wire during future trenching operations. The tape shall be three-inch (3") wide polyethylene, APWA uniform color coded. Above water facilities the tape shall be blue, permanently printed "CAUTION BURIED WATER LINE BELOW." Above sewer facilities, the tape shall be green, permanently printed "CAUTION BURIED SEWER LINE BELOW."

Where the depth is such that the pipe zone extends into the street zone, that portion of the pipe zone within the street zone shall be compacted as set forth in Section B-10 of these specifications.

#### **B-8 PROCEDURE ABOVE PIPE ZONE**

The remaining portion of the trench to within 2-1/2 feet of the finished roadway surface or ground surface, as the case may be, shall be backfilled, compacted and/or consolidated by approved methods to obtain a relative compaction of 95%. Backfilling may be done with native trench side material except that no oil cake, bituminous pavement, recycled concrete, rock or other lumpy material shall be used in the backfill, unless these materials are scattered and do not exceed 3 inches in any dimension. Material of perishable, spongy, or otherwise improper nature shall not be used in backfilling and no material greater than 3 inches in any dimension shall be placed within 1 foot of any pipe, manhole or structure.

#### **B-9 COMPACTION IN OPEN FIELDS**

In open fields, where paving or structures will not be above the excavated area, the remaining portion of the trench to within 2-1/2 feet of the finished ground surface shall be backfilled, compacted and/or consolidated by approved methods to obtain a relative compaction of 95% standard proctor density in accordance with ASTM D698, leaving the top slightly mounded.

#### **B-10 PROCEDURE AT STREET ZONE**

Compaction and backfill material shall meet the requirements of other government agencies in areas where these agencies have jurisdiction. In locations where no other jurisdiction applies, the following District specifications apply.



The top 2-1/2 feet of the trench within roadbed areas shall be compacted in horizontal layers not exceeding 8 inches in thickness, using approved hand, pneumatic or mechanical type tampers to obtain a relative compaction of 95% with a moisture content within 2% of optimum. Flooding and jetting will not be permitted within roadbed areas.

The roadbed area as used herein shall be considered as extending two feet beyond the curbs, gutters or paved shoulders.

From existing street grade to 2-1/2 feet below street grade, the material for backfill may contain stones ranging in size up to 2 inches in diameter in quantity, but not exceeding 20% of the volume, where said coarse materials are well distributed throughout the finer material and the specified compaction can be obtained.

#### **B-11 EXCESS EXCAVATED MATERIAL**

All surplus material not required for backfill shall be disposed of by the Contractor outside the limits of the public rights-of-way and/or easements.

No excavated material shall be deposited on private property, unless written permission is secured by the Owner. Before the District will accept the work as being completed, the Owner shall file a written release signed by all property owners with whom he has entered into agreements for disposal of excess excavated material, absolving the District from any liability connected therewith.

#### **B-12 IMPORTED PIPE BACKFILL MATERIAL**

Whenever the excavated material is not suitable for backfill, as determined by the District, the Contractor shall arrange for and furnish suitable imported material.

### **C STRUCTURES EARTHWORK**

#### **C-1 GENERAL**

Structure excavation shall include the removal of all material of whatever nature necessary for the construction of structures and foundations required.

The sides of excavations for structures where all vertical surfaces are formed shall be sufficient to leave at least 2 feet in the clear as measured from the extreme outside of formwork or structure, as the case may be. Where excavation is inadvertently carried below designated elevations, suitable provision shall be made for adjustment of construction, as directed by the District, to meet requirements incurred by the deeper excavation beneath structures, and overdepth excavation in such locations shall be rectified by backfilling with sand, graded gravel, or

concrete as directed by the District. All overdepth excavations for footings shall be backfilled with Class C concrete, as defined in the Technical Specifications for Concrete Construction.

**C-2 SUBBASE FOR STRUCTURES**

Where indicated on the Plans, a crushed rock subbase shall extend from firm ground undisturbed by the construction operations to the structure base slab for all concrete structures. Any remaining disturbed or loose material shall be removed before the crushed rock subbase is placed. The subbase shall be compacted to the specified compaction, 90% minimum or as approved by the District, by means of a vibratory roller.

**C-3 SUBBASE MATERIALS**

Mineral aggregate shall conform with the following gradation requirements:

Sieve Size	Percent Passing Sieves
3/4-inch	90 – 100
No. 4	40 – 60
No. 30	13 – 23
No. 200	0 – 2

**C-4 BACKFILLING**

After compaction of foundation footings and walls of the structure and of construction below the elevation of the final grade and prior to backfilling, all forms shall be removed, and the excavation shall be cleared of debris. Backfilling shall not be commenced until the structure and excavation involved shall have been inspected and approved by the District. Material for backfilling shall consist of selected excavation material, imported sand, gravel or other material approved by the District and shall be free of trash, lumber or other debris. No material of a perishable or spongy nature and no stone or piece of rock greater than 4 inches in the greatest dimension shall be used in backfilling.

Compaction shall be obtained by means of mechanical tamping. Backfill of excavated material shall be placed in horizontal layers not exceeding 9 inches in thickness and shall have a moisture content within 2% of optimum, such that the required degree of compaction may be obtained. Each layer shall be compacted by hand, mechanical tampers, or other suitable equipment to the specified relative compaction.

Where backfill or fill is against only one side of a concrete structure, no fill shall be placed until the concrete in place has obtained an acceptable seven-day strength based upon a concrete cylinder test, unless otherwise directed by the District.

Particular care shall be exercised when backfilling at the various structures to obtain adequate compaction beneath pipes connected thereto and to avoid injury or displacement of such pipes or projections of the structures.

--END OF SECTION--

**TECHNICAL SPECIFICATIONS  
FOR  
DUCTILE IRON WATER PIPE**

**A PIPE**

**A-1 MATERIAL**

Ductile iron pipe (DIP) used for water distribution systems shall be manufactured in accordance with AWWA C151 and cement mortar lined in conformance with AWWA C104.

**A-2 WALL THICKNESS**

The class of pipe used shall be determined by the procedures outlined in AWWA C150. Minimum internal design pressure shall be 150 psi plus an "anticipated surge pressure" of 100 psi.

**A-3 PIPE END CONFIGURATIONS**

Pipe end configurations (push-on, mechanical joint, restrained or flanged) shall be indicated on the Plans. Mechanical joints and push-on joints shall conform to the requirements of AWWA C111. Flanged joints shall conform to AWWA C115, if flanges are threaded, or to the flanged joint provisions of AWWA C110 if flanges are cast integrally with the pipe. Threaded flanges are to be used only on pipe spools shorter than a standard length of ductile iron pipe (18 feet or 20 feet) needed in special circumstances as shown on the Plans and approved by the District.

**A-4 MARKING**

Each joint of DIP shall be clearly marked with the following information by the pipe manufacturer:

Weight

Class (per AWWA C150) or nominal thickness

Casting period

Manufacturer's mark

Country where cast

Year cast

The letters "DI" or "DUCTILE"

**B FITTINGS**

Fittings shall be manufactured of ductile iron conforming to the requirements of AWWA C110 with a 350 psi pressure rating. All fittings shall be cement-mortar lined in accordance with AWWA C104.

Ductile iron fittings conforming to AWWA C-153 ("compact fittings") may be used where restrained joint fittings and pipe are used to resist thrust instead of concrete thrust blocks, subject to approval by the District. "Compact fittings", if used, shall be cement mortar lined in accordance with AWWA C104.

Fitting ends shall be selected to match the end of the pipe joint, valve, or fitting to which it is to be joined. Requirements for fitting end configurations are outlined in AWWA C110 and C111 (refer to A-3, Pipe End Configurations). Fittings shall be flanged to valves.

Gaskets for mechanical joints shall conform to the requirements of AWWA C111 with duck tips and backs.

Gaskets for flange joints shall be rubber, full-face, bolt holes prepunched, and 1/8-inch thick conforming to the dimensions for flanges in AWWA C110.

## **C      INSTALLATION**

Trenching, bedding of DIP, and backfilling of trenches shall conform to the Standard Specification for Earthwork. Curved alignments are allowable without the need for fittings provided the maximum deflection at a pipe joint does not exceed 5 degrees for pipe equal to or less than 12-inches in diameter or 3 degrees for pipe 14 through 18 inches in diameter (in no case shall deflections at pipe joints exceed manufacturer's recommendations). Deflecting pipe joints is allowable only for push-on or mechanical jointed pipe.

All DIP shall be encased in polyethylene wrap per AWWA C105. Tape for securing the polyethylene wrap shall be 2-inch wide adhesive tape such as Polyken 900 (polyethylene), Scotchwrap 5 (polyvinyl) or equal as approved by the District. (Refer to Technical Specifications for Plastic Film Wrap).

In addition to the tracer wire, non-detectable warning tape shall be placed above the pipe and tracer wire to alert workers to the presence of the pipe and/or tracer wire during future trenching operations. The tape shall be three-inch (3") wide polyethylene, APWA uniform color coded blue, permanently printed "CAUTION BURIED WATER LINE BELOW." The tracer wire and warning tape shall be located as shown on Drawing W-2, or as directed by the District. Tracer wire and/or warning tape shall be replaced if damaged by any subsequent trenching operation.

At times when pipe laying is not in progress, the open end of pipes shall be sealed temporarily to prevent the entry of water, debris, small animals, and similar types of contamination. Such temporary seals shall also be vermin-proof, and secured so as to discourage tampering by children.



#### **D THRUST RESTRAINT**

Thrust restraint for DIP may be provided by the use of concrete thrust blocks or restrained joints. Acceptable joint restraint devices include special joint designs that are standard products of domestic DIP manufacturers. If restrained joints are to be used, the Owner shall submit to the District for review and approval information of the type of joint proposed along with calculations for the number of joints of DIP to be restrained on each side of a fitting or valve. The type of joint and number of joints of DIP to be restrained at each location shall be shown on the Plans.

If concrete thrust blocks are to be used, they shall be called out on the Plans at each point needed. Thrust blocks shall be constructed of concrete containing six sacks of cement per cubic yard and placed between the fitting to be anchored and undisturbed earth. The bearing area against undisturbed earth shall be called out on the Plans at each location a thrust block is required. The concrete shall be placed so that pipe joints and fittings will be accessible for repairs.

#### **E HYDROSTATIC TESTING AND DISINFECTION OF POTABLE WATER LINES**

Installed pipe shall be tested and disinfected in accordance with the Testing and Disinfection of Water Pipe Technical Specification.

--END OF SECTION--

**TECHNICAL SPECIFICATIONS  
FOR  
POLYVINYL CHLORIDE WATER PIPE**

**A PIPE**

**A-1 CLASSIFICATION**

Polyvinyl chloride (PVC) pipe shall be manufactured for use in potable water service and shall conform to Class 235 (minimum) as described in AWWA C900 for pipe up to 12 inches diameter.

The class of pipe used shall be determined by the procedures outlined in AWWA C900 with a working pressure of 150 psi and an occasional surge pressure of 100 psi.

**A-2 SIZE**

This specification covers PVC pipe with nominal diameters not exceeding 12 inches. If larger diameter pipe is required, PVC pipe may be used if approved in writing by the District.

**A-3 JOINTS**

Only elastomeric gasket jointed PVC pipe shall be used. Either the integral bell design or the separate sleeve-type coupling joint may be used. Gaskets shall meet the requirement of AWWA C900. Oil resistant gaskets may be required in some instances by the District. PVC pipe may not be used in areas subject to contamination by petroleum distillates.

**A-4 MARKING**

Each standard length of PVC, pipe and coupling if separate sleeve-type couplings are used, shall be marked at intervals of not more than 5 ft with the nominal diameter, the OD base (cast iron pipe OD base is required), the material code (PVC), the dimension ratio (DR) number, AWWA pressure class (for example, PC 165), test pressure for hydrotested pipe (for example, T330) or if not tested, "NOT HYDROSTATIC PROOF TESTED.", AWWA Standard (i.e., ANSI/AWWA C900), the manufacturer's name or trademark and production run record or lot code, and seal (mark) of the testing agency that verified the suitability of the pipe material for potable water service.

If pipe is stored at a project site, it shall not be stacked higher than four feet and no weight shall be placed on bells or couplings. Stored pipe shall be covered to protect it from ultraviolet light (sun's rays). PVC pipe with noticeable color changes resulting from exposure to ultraviolet light may be rejected at the discretion of the District.

## **A-5 CERTIFICATION FOR POTABLE-WATER SERVICE**

PVC compounds and products shall be tested for chemical extractants and certified as suitable for potable-water service by an accredited testing agency acceptable to District. The basis of certification shall be the requirements specified in NSF/ANSI 61.

## **B FITTINGS**

Fittings shall be manufactured of ductile iron conforming to the requirements of AWWA C110, 350 psi pressure rating. All fittings shall be cement-mortar lined in accordance with AWWA C104.

Ductile iron fittings conforming to AWWA C153 ("compact fittings") may be used where restrained joint fittings and pipe are used to resist thrust instead of concrete thrust blocks, subject to approval by the District. "Compact fittings", if used, shall be cement mortar lined in accordance with AWWA C104.

Fittings shall be rubber ring, hub end, suitable for direct connection to the mating PVC pipe except when connecting to a valve. Valves and fittings shall be flanged together.

Flanges shall conform to the bolt circle and bolt hole dimensions for flanges in AWWA C110. Gaskets for flanged joints shall be full-face, cut from 1/8-inch thick rubber with bolt holes prepunched.

Nuts and bolts for bolting flanged joints shall be standard hexagonal head machine bolts and hexagonal nuts conforming to the requirements of ASTM A307, Grade B. All buried flanged-end fittings shall be bolted with cadmium-plated steel nuts and bolts. All bolts shall be lubricated with graphite and oil. Flanged faces shall be wire brushed and cleaned prior to joining each flange.

All buried fittings and valves shall be wrapped in polyethylene film per the Technical Specifications for Plastic Film Wrap.

## **C INSTALLATION**

Trenching, bedding of PVC pipe, and backfilling of trenches shall conform to the Technical Specification for Earthwork and to AWWA C605.

One acceptable method of embedment is shown in Standard Drawing W-2. The Owner's Engineer shall select appropriate bedding constant ( $K$ ) and soil modulus ( $E'$ ) values and calculate pipe deflection per the design information provided in AWWA Manual M23. The type of pipe embedment shall be selected so as to prevent a vertical cross-section long-term ring deflection of more than 7.5 percent.

Unless a separate sleeve-type coupling jointed pipe is used, the manufacturer of which recommends deflecting pipe at the joints to follow a curved alignment, deviations from a straight pipeline alignment shall be made only by use of cast iron fittings, or pipe couplings with District approval. Bending of PVC pipe will not be permitted. Joining of pipe shall be in accordance with the manufacturer's printed instructions, which shall be furnished to the District. Fittings shall be supported independently of the pipe. Five-foot lengths of pipe shall be used in and out of each fitting and valve and wherever pipe passes through a rigid structure.

Concrete thrust blocks shall be installed at the locations and in accordance with the Plans and shall consist of concrete containing not less than six sacks of portland cement per cubic yard. Concrete thrust blocks shall be placed between the undisturbed ground and the fittings to be anchored. The bearing area against undisturbed soil shall be as shown on the Plans. The concrete shall be so placed that the pipe joints and fittings will be accessible to repairs.

Insulated tracer wire shall be placed immediately above all PVC pipe and service laterals, tracer wire shall be 12-gauge minimum insulated for protection from corrosion. Bring tracer wire up in valve boxes, meter boxes, etc. Coil wire in box with sufficient length to extend two feet above finish grade.

In addition to the tracer wire, non-detectable warning tape shall be placed above the pipe and tracer wire to alert workers to the presence of the pipe and/or tracer wire during future trenching operations. The tape shall be three-inch (3") wide polyethylene, APWA uniform color coded blue, permanently printed "CAUTION BURIED WATER LINE BELOW." The tracer wire and warning tape shall be located as shown on Drawing W-2, or as directed by the District. Tracer wire and/or warning tape shall be replaced if damaged by any subsequent trenching operation.

At times when pipe laying is not in progress, the open end of pipes shall be sealed temporarily to prevent the entry of water, debris, small animals, and similar types of contamination. Such temporary seals shall also be vermin-proof, and secured so as to discourage tampering by children.

#### **D HYDROSTATIC TESTING AND DISINFECTION OF POTABLE WATER LINES**

Installed pipe shall be tested and disinfected in accordance with the Technical Specification for Testing and Disinfection of Water Pipe.

--END OF SECTION--

**TECHNICAL SPECIFICATIONS  
FOR  
RESILIENT SEAT GATE VALVES**

**A GENERAL**

These specifications designate the requirements for the manufacture and installation of resilient seat gate valves.

**B MATERIALS AND WORKMANSHIP**

**B-1 GENERAL**

Resilient seat gate valves shall conform to the requirements of AWWA C-509 and the requirements set forth herein.

Resilient seat gate valves, unless otherwise indicated, shall be the same size as the main in which they are installed and shall be connected to ductile iron fittings by flanges or mechanical joints. All valves shall be non-rising stem, counterclockwise opening. Valves shall have the same type ends as the pipe or fitting on which they are installed. Valves are to have 2-inch-square cast-iron operating nuts. Valves shall be marked with raised lettering cast on the body indicating manufacture and working pressure. Minimum water working pressure to be 200 psig.

Valves shall be iron bodied, bronze mounted, with modified wedge disc or parallel-faced disk with replaceable resilient seats. The bronze stem nut shall be solid bronze conforming to ASTM B-62 (4-6% zinc). The bronze stem shall be cast bronze or forged bronze bar stock containing a maximum of 2% zinc. Valves shall be manufactured by Mueller, Clow or approved equivalent.

**B-2 INTERIOR AND EXTERIOR COATINGS**

The interior of the valve body and wedge shall be coated at the place of manufacture. Surfaces shall be sandblasted in accordance with SSPC-SP-5 (white metal blast cleaning). Interior coating shall consist of two coats of epoxy resin, Keysite 740 or equal, applied to a minimum total dry-film thickness of 10 mils. The exterior of valves shall be coated with epoxy at the place of manufacture.

**B-3 VALVE BOXES**

Valve box assemblies shall conform to the requirements shown on the Standard Detail for Valve Boxes W-7.

**B-4 FLANGED VALVES**

Valves with flanged ends shall be bolted with cadmium plated steel machine bolts and nuts conforming to ASTM A-307, Grade B. All bolt threads shall be lubricated with graphite and oil prior to installation. Flange faces shall be wire brushed and cleaned prior to joining each flange. Gaskets shall be full-face, 1/8-inch neoprene (durometer 60-80) with prepunched bolt holes.



**B-5 MECHANICAL JOINTED VALVES**

Valves with mechanical joint ends shall conform to the requirements of AWWA C111. Gaskets shall conform to AWWA C111 with duck tips and backs.

**B-6 PLASTIC FILM WRAP**

All buried valves and fittings shall be completely encapsulated with a 10-mil wrap of polyethylene film as set forth in the Technical Specifications for Plastic Film Wrap of Valves, Flanges and Other Fittings.

--END OF SECTION--

**TECHNICAL SPECIFICATIONS  
FOR  
PLASTIC FILM WRAP OF VALVES, FLANGES  
AND OTHER FITTINGS**

**A GENERAL**

This specification designates the requirements for the manufacture and installation of polyethylene plastic wrap around all valves, flanges, and other fittings when buried underground.

**B MATERIALS**

The polyethylene film shall be of virgin polyethylene and shall meet the requirements of ASTM D 1248 for Type I, Class A, Grade E-1 and shall have a flow rate not exceeding 0.4 grams/minute per ASTM D 1238.

The polyethylene film shall be 10 mils in thickness. The length shall be sufficient to firmly attach the film to the pipe on either side of the valve, flange or fitting. The following minimum flat sheet widths shall be used for the specified valve sizes:

<b>Nominal Valve or Flange Size (Inches)</b>	<b>Minimum Flat Sheet Width (Inches)</b>
6	24
8	24
10	30
12	36
16 and Larger	48

Tape for securing the polyethylene wrap shall be 2-inch-wide adhesive tape, such as Polyken 900 (polyethylene), Scotchwrap 5 (polyvinyl), or approved equal. The tape shall be such that the adhesive will bond securely to both metal surfaces and polyethylene film.

**C INSTALLATION**

The valves shall be wrapped by passing the flat sheet of film under the valve bottom and bringing the ends up around the body to the stem and securing it in place with 2-inch strips of the plastic adhesive tape. The polyethylene shall be secured around the valve stem in such a manner as to leave the stem free to operate. The film shall be brought completely around the flanges and secured to the pipe with plastic adhesive tape on either side of the valve, flange or fitting.

--END OF SECTION --



**TECHNICAL SPECIFICATIONS  
FOR  
WATER SERVICES**

**A WATER SERVICES**

Water services shall be installed at the location shown on the Plans using the type of materials, valves, and appurtenances as shown on the Standard Details included with these Specifications. The water services shall be terminated at an angle meter stop at the locations shown on the Standard Details.

**B WATER METERS**

Water meters shall be installed by the District (refer to Standard Details W-8 and W-9).

**C METER BOXES**

Concrete meter boxes shall be purchased and installed by the Owner for each meter connection as shown in Standard Details W-8 and W-9.

**D MATERIALS**

Schedule 80 PVC or copper tubing shall be used for all services.

Angle meter stop, corporation stop, and customer valve shall be ball type. Angle meter stops and customer valves shall be lockable. Water service materials are listed below, and are also indicated on the appropriate standard detail. Alternate equivalent materials may only be used with written approval from the District.

**D-1 SERVICE SADDLES**

For AC/DI PIPE

1" – 2" FIP TAP W/BRZ BODY AND BRZ STRAPS

JAMES JONES PART # J979

FORD PART # 202B

For PVC C900 PIPE

1" – 2" FIP TAP W/BRZ BODY AND SS STRAPS

JAMES JONES PART # J969

FORD PART # 202BS

**D-2 CORP STOPS - BALL TYPE**

1"- 2" MIP X CTS COMPRESSION BALL CORP

JAMES JONES PART # J1935

FORD PART #FB1100

1" – 2" MIP X PVC COMPRESSION BALL CORP  
JAMES JONES PART #J1977  
FORD PART # FB1102

**D-3 ANGLE METER STOP - BALL TYPE**

1" CTS X MCN COMPRESSION ANGLE BALL VALVE  
JAMES JONES PART# J1963W  
FORD PART # BA43-W

1-1/2" – 2" CTS COMPRESSION X METER FLG BALL VALVE  
JAMES JONES PART # J1975W  
FORD PART # BFA43-W

1" PVC COMPRESSION X MCN ANGLE BALL VALVE  
JAMES JONES PART #J4211W  
FORD PART # NOT AVAILABLE

1-1/2" – 2" PVC COMPRESSION X METER FLANGE  
JAMES JONES PART # J1979W  
FORD PART # BFA43-W

**D-4 CUSTOMER BALL VALVE**

1" FIP X MCN BALL VALVE W/LEVER HANDLE  
JAMES JONE PART # J1908W  
FORD PART # B13-W

1-1/2" - 2" FIP X METER FLANGE BALL VALVE W/LEVER HANDLE  
JAMES JONES PART # J1913W  
FORD PART # BF13-W

--END OF SECTION--

**TECHNICAL SPECIFICATIONS  
FOR  
WATER SERVICES FOR COMBINED RESIDENTIAL AND FIRE SPRINKLER SYSTEMS**

**A WATER SERVICES**

Water services shall be installed at the location shown on the Plans using the type of materials, valves, and appurtenances as shown on the Standard Details included with these Specifications. The water services shall be terminated at the locations shown on the Standard Details. The service shall terminate at a tee with one outlet plugged for future connection to the fire sprinkler system and the other outlet shall have a locking valve, plugged for future connection to the residential water system.

**B WATER METERS**

Water meter idlers (jumpers) shall be installed at the time the water services are installed. Water meters shall be installed by the District (refer to Standard Details W-8, W-8A, and W-8B).

**C METER BOXES**

Concrete meter boxes shall be purchased and installed by the Owner for each meter connection as shown in Standard Details W-8, W-8A, and W-8B.

**D MATERIALS**

Schedule 80 PVC or copper tubing shall be used for all services.

Angle meter stop, corporation stop, and customer valve shall be ball type. Angle meter stops and customer valves shall be lockable. Water service materials are listed below, and are also indicated on the appropriate standard detail. Alternate equivalent materials may only be used with written approval from the District.

**D-1 SERVICE SADDLES**

For AC/DI PIPE

1" – 2" FIP TAP W/BRZ BODY AND BRZ STRAPS

JAMES JONES PART # J979

FORD PART # 202B

For PVC C900 PIPE

1" – 2" FIP TAP W/BRZ BODY AND SS STRAPS

JAMES JONES PART # J969

FORD PART # 202BS

**D-2 CORP STOPS - BALL TYPE**

1"- 2" MIP X CTS COMPRESSION BALL CORP

JAMES JONES PART # J1935



FORD PART #FB1100

1" – 2" MIP X PVC COMPRESSION BALL CORP  
JAMES JONES PART #J1977  
FORD PART # FB1102

**D-3 ANGLE METER STOP - BALL TYPE**

1" CTS X MCN COMPRESSION ANGLE BALL VALVE  
JAMES JONES PART# J1963W  
FORD PART # BA43-W

1" PVC COMPRESSION X MCN ANGLE BALL VALVE  
JAMES JONES PART #J4211W  
FORD PART # BA63-W

**D-4 CUSTOMER BALL VALVE**

1" FIP X MCN BALL VALVE W/LEVER HANDLE  
JAMES JONE PART # J1900W  
FORD PART # B11-W

--END OF SECTION--

**TECHNICAL SPECIFICATIONS  
FOR  
CONNECTIONS TO DOMESTIC WATER SYSTEM**

**A WATER MAINS**

Whenever the location of existing mains makes it necessary to use a gradual transition on the alignment of the proposed mains, the transition shall be made in the shortest practical distance with the maximum deflection per joint for curves not to exceed 5 degrees if DIP is used. If PVC pipe is used, ductile iron fittings will be required to make the transition. All tie-ins, taps, saddles and connections to existing District mains shall be made in the presence of an authorized District representative.

**B VALVES AND HYDRANTS**

Installation of valves and hydrants to existing mains shall be made by use of tapping sleeves and valves or by cutting in fittings as determined by the District. Tapping sleeves and valves shall be subject to approval by the District. Tapping valves shall be a resilient seat gate valve as specified in the Technical Specifications for Resilient Seat Gate Valves.

**C CROSS-CONNECTION CONTROL REQUIREMENTS**

Cross-connections of any type that permit a backflow condition from any source or system other than that of the District's potable water mains are prohibited. A connection constituting a potential or actual backflow hazard is not permissible unless a backflow device or air gap, which is approved by the California State Department of Health Services and complies with Title 17 of the California State Administrative Code, is installed. Such an installation shall at all times be subject to inspection and regulation by the District and San Luis Obispo County Public Health Department for the purpose of avoiding possibility of backflow.

The District will not provide any water service to any premises or continue to serve water unless the public water supply is protected as required by State and County regulations.

Connection to residential fire sprinkler systems shall require the use of a double check valve backflow device. Use of another type of backflow prevention device will require the approval of the District.

Backflow preventive devices shall be approved by the County and shall be installed by and maintained at the expense of the water user.

The County will test such devices. The owner of the property shall overhaul or replace backflow preventers if they are found defective.

Service of water to any premises may be discontinued by the District if a backflow prevention device required by the County is not installed; if any defect is found in an installed backflow preventative device has been removed or bypassed; or if unprotected cross-connections exist on the premises; and service will not be restored until such conditions or defect are corrected.

Regulations Relating to Cross-Connections, California Administrative Code – Title 17 – Public Health

Manual of Cross-Connection Control Procedures and Practices, State of California, Department of Health Services.

Water users which have multiple water systems shall abide by the requirements specified in Title 17 for marking safe and unsafe water lines, and have a designated water supervisor, if required by the District.

--END OF SECTION--

**TECHNICAL SPECIFICATIONS  
FOR  
TESTING AND DISINFECTION OF WATER PIPE**

**A HYDROSTATIC TESTING**

PVC and Ductile Iron water lines shall be hydrostatic tested and disinfected in conformance with AWWA 605-05 and AWWA C600-05, respectively, and in accordance with the following specifications.

After completion of the pipeline installation, the line shall be tested under a hydrostatic pressure test as at a test pressure noted below, for a period of not less than 4 hours for each section of pipe tested. The pressure shall be maintained by restoring the test pressure whenever it falls 5 psi. At the conclusion of the 4 hours, the test pressure shall be restored and all water used during the tests shall be accurately measured to determine the testing allowance.

The Owner shall provide suitable calibrated tanks for measurement of leakage and shall furnish the necessary bulkheads, piping, calibrated gauges, pumps, power, labor and other means, and shall do everything necessary for filling the pipeline and for obtaining and maintaining the required water pressure.

The testing allowance shall be defined as the quantity of water that must be supplied to the pipe section being tested to maintain a pressure within 5 psi (34 kPa) of the specified hydrostatic test pressure. No installation will be accepted if the quantity of makeup water is greater than that determined by the formula:

$$Q = \frac{LD\sqrt{P}}{148,000}$$

Where:

- $Q$  = quantity of makeup water, in gallons per hour
- $L$  = length of pipe section being tested, in ft
- $D$  = nominal diameter of the pipe, in in.
- $P$  = average test pressure during the hydrostatic test, in pounds per square in. (gauge)

This formula is based on a testing allowance of 10.5 gpd/mi/in. of nominal diameter at a pressure of 150 psi.

<b>Allowable Leakage per 50 Joints for 4 Hour Test Duration</b>					
<b>Test Pressure</b>	<b>Nominal Pipe Diameter, in.</b>				
	<b>4</b>	<b>6</b>	<b>8</b>	<b>10</b>	<b>12</b>

<b>200</b>	1.53	2.29	3.06	3.82	4.59
<b>175</b>	1.43	2.15	2.86	3.58	4.29
<b>150</b>	1.32	1.99	2.65	3.31	3.97

The Owner, at his own expense, shall do all excavating necessary to locate and repair leaks or other defects which may develop under test, including removal of backfill already placed. The Owner shall make all repairs necessary to secure the required water tightness and shall replace excavated material, following which the test shall be repeated until the pipe is found satisfactory.

Regardless of the rate of leakage, all detectable leaks shall be repaired.

**A-1 SPECIAL PROVISIONS FOR HYDROSTATIC TESTING OF PVC WATER MAINS**

After completion of the pipeline installation, the line shall be tested in conformance with AWWA C605-05 and these special provisions.

The hydrostatic test pressure shall not be less than the greater of (a) 1.25 times the maximum anticipated sustained working pressure at the highest point along the test section, or (b) 150 psi, as measured at the low point of the pipeline, unless the pressure exceeds the design pressure limit for any pipe, thrust restraint, valve fitting, or other appurtenance of the test section. In no case shall the test pressure exceed the design pressure limit for any pipe, thrust restraint, valve, fitting, or other appurtenance of the test section.

**A-2 SPECIAL PROVISIONS FOR HYDROSTATIC TESTING OF DUCTILE IRON WATER MAINS**

After completion of the pipeline installation, the line shall be tested in conformance with AWWA C600-05 and these special provisions.

The hydrostatic test pressure shall not be less than the greater of (a) 1.25 times the stated working pressure of the pipeline measured at the highest elevation along the test section, (b) 1.5 times the stated working pressure measured at the lowest elevation of the test section, or (c) 150 psi measured at the low point of the test section. The test pressure shall not exceed the thrust restraint design pressures or 1.5 times the pressure rating of the pipe or joint, whichever is less (as specified by the manufacturer).

**B DISINFECTION OF WATER LINES**

After pressure testing and prior to acceptance of the work, newly installed water mains, or water mains that have been taken out of service for maintenance or repair, including all valves, fittings, hydrants and other accessories, shall be disinfected and sampled for bacteriological quality in accordance with American Water Works Association

Standard C651, which is hereby incorporated by reference. Disinfection shall be accomplished using the Continuous-Feed Method of AWWA C651. The Tablet Method and Slug Method will not be allowed.

Chlorine residual shall be determined in accordance with the method specified in the Appendix to AWWA C651 with amounts of chlorine sufficient to produce a dosage of 40-50 mg/L free chlorine and a residual of not less than 10 mg/L free chlorine after 24 hours. The Contractor shall provide and keep chlorine residual testing and indicating apparatus available on the site during the disinfection period.

During the chlorination process, all valves and accessories shall be operated. After chlorination, the water shall be flushed from the line at its extremities until the replacement water tests are equal, chemically and bacteriologically, to those of the permanent supply.

It shall be the Owner's responsibility to determine the method of disposal, treatment (if any), obtain permission from the applicable agency, and comply with all federal, state, county, and local regulations regarding treatment and disposal of the chlorinated water.

The Owner shall retain a qualified laboratory to perform a bacteriological test. Such a test shall meet the California Department of Health Services requirements for domestic water purposes prior to acceptance by the District for integration and use in the system. The cost of the test(s) shall be born by the Owner.

After final flushing and before the new water main is connected to the distribution system, two consecutive sets of acceptable samples, taken at least 24 hr apart, shall be collected from the new main. At least one set of samples shall be collected from every 1,200 ft (366 m) of the new water main, plus one set from the end of the line and at least one set from each branch. Samples from new mains shall be negative for coliform bacteria prior to the new main(s) being placed into service.

The new water main shall be kept physically disconnected from the active distribution system until satisfactory completion of the bacteriological test.

--END OF SECTION--



**TECHNICAL SPECIFICATIONS  
FOR  
POLYVINYL CHLORIDE SEWER PIPE AND FITTINGS**

**A                   GENERAL**

Polyvinyl chloride PVC pipe may be used on residential tract sewers and residential house laterals only to sizes not exceeding 12 inches in diameter. Coordinate with District for larger pipe requirements.

**B                   MATERIALS**

PVC pipe, fittings, couplings, and joints shall conform to the requirements of ASTM D-3034, SDR 35, and shall have gasketed joints.

**B-1   IDENTIFICATION MARKS**

All pipe, fittings, and couplings shall be clearly marked at an interval not to exceed 5 feet as follows:

- (1)   Nominal pipe diameter.
- (2)   PVC cell classification.
- (3)   Company, plant, shift, ASTM, SDR, and date designation.
- (4)   Service designation or legend.

For fittings and couplings, the SDR designation is not required.

**B-2   CELL CLASSIFICATION**

Pipe shall be made of PVC plastic having a cell classification of 12454-B, 12454-C, or 13364-B as defined in ASTM D 1784. The fittings shall be made of PVC plastic having a cell classification of 12454-B, 12454-C, or 13343-C per ASTM D-1784.

**B-3   TEST REQUIREMENTS**

Pipe, fittings, and couplings shall meet the requirements of the section titled "Requirements" of ASTM D-3034. During production of the pipe, the manufacturer shall perform the specified tests for each pipe marking. A certification by the manufacturer indicating compliance with specification requirements shall be delivered with the pipe. The certification shall include the test result data.

**B-4   GASKETS**

Gaskets shall conform to ASTM F-477 and ASTM D-3212. A single rubber gasket shall be installed in each bell end of a joint of pipe or fitting.

## **C FITTINGS**

PVC fittings shall include branches of every type and stoppers. Fittings shall be furnished and installed in conformance with these specifications.

### **C-1 BRANCHES**

Branches shall be securely and completely fastened to the barrel of the fitting in the process of manufacture. Wye branches shall have their axes 45 degrees to the longitudinal axis of the pipe measured from the socket end. All branches shall terminate in sockets, and the barrel for the branch shall be of sufficient length to permit making a proper joint when the lateral pipe is inserted in the branch socket.

The material and quality of PVC fittings and the joints for fittings shall conform to the applicable provisions of these specifications.

Installation of Branches: PVC wyes, tees and other types of branches shall be furnished and installed along with PVC sewer. Wyes shall be installed for all sewer house connections including foreseeable future sewer house connections. The longitudinal barrel of branch fittings to be placed in line and grade with the sewer mains shall be of the same diameter, quality and type as said sewer. Installation, earthwork and bedding for branches shall conform to the applicable provisions set forth for mainline sewer pipe and the Technical Specifications for Sewer Laterals. The branch of wye fittings shall be inclined upward at an angle of 45 degrees from a horizontal line. No wye or tee for sewer laterals shall be placed closer than 5 feet in the downstream side to the centerline of any structure.

Where sewer laterals are not constructed, the wye or tee branch socket shall be plugged.

All joints for stoppers shall be adequate to withstand the internal pressure of the leakage and/or infiltration test; however, joints shall be made in such a manner that they may be removed without injury to the socket.

## **D INSTALLATION**

The bedding and pipe zone material for PVC sewer pipe shall be placed from 12-inches below the bottom to 12-inches over the top of the pipe and shall be pipe bedding aggregate conforming to the requirements of the Technical Specifications for Earthwork and the Standard Details.

Trench bedding and backfill shall be placed in the same manner as described for water mains, including use of tracer wire and warning tape, except as follows: The non-detectable warning tape shall be three-inch (3") wide polyethylene, APWA uniform color coded green, permanently printed "CAUTION BURIED SEWER LINE BELOW."

All installation of PVC pipe shall be in conformance with ASTM D-2321 (latest edition). During the months of April thru October, PVC pipe exposed to the sun prior to laying shall be shaded from direct sun for at least thirty (30) minutes before connection is made to manholes. Allowance shall also be made for the movement of pipe at house branch locations.

Any pipe which does not comply with the Specifications, is out of round, and has been rejected by the District, shall be removed from the jobsite and disposed of by the Owner.

#### **D-1 LAYING PVC PLASTIC PIPE**

Trenches shall be kept free of water during the laying operation. All pipe shall be laid without break, upgrade from structure to structure, with the bell ends of the pipe upgrade. Pipe shall be laid to the line and grade given so as to form a close concentric joint with the adjoining pipe and prevent sudden offsets of the flow line. The interior of the sewer pipe shall be cleaned of all dirt and superfluous materials of all description as the work progresses.

#### **D-2 JOINING SYSTEMS**

All pipes shall have a home mark on the spigot end to indicate proper penetration when the joint is made. The socket and spigot configurations for the fittings and couplings shall be compatible to those used for the pipe. Pipe shall be joined with elastomeric gasketed joints manufactured with a socket configuration which will preclude improper installation of the gasket and will ensure the gasket remains in place during the joining operation.

Joining of pipe shall be in accordance with the manufacturer's printed instructions, which shall be furnished to the District. The spigot end shall be inserted to the proper depth of the socket as indicated by the home mark.

#### **D-3 SHORT JOINTS AT MANHOLES AND STRUCTURES**

A 2-foot joint of PVC shall be placed at inlets and outlets to each manhole or structure to be constructed.

--END OF SECTION--

**TECHNICAL SPECIFICATIONS  
FOR  
CONNECTIONS TO EXISTING SEWER PIPE**

**A      TEMPORARY HANDLING OF SEWAGE**

Certain work in connection with tying into existing sewers and manholes may require the temporary handling of sewage either by temporary bypass lines, pumping, bulkheading at low flows, or other means to be approved by the District. Sewage so diverted shall be handled in a manner so as not to create a public nuisance or health hazard. The Owner shall be responsible for any costs related to making these connections.

**B      REMODELING EXISTING MANHOLES**

Where an existing manhole base has to be reworked, provisions shall be made to keep pieces of concrete and debris out of the sewer. Where new flow-through channels have to be cut, they shall be cut so that the resulting section is smooth and conforms to the intended shape. Deviation from form and grade shall not be greater than 1/4-inch. Where holes are required in existing manhole walls for new or revamped connections, the Owner will be required to use coring-type equipment if, in the opinion of the District, the Contractor's method of making holes will result in excessive damage to existing manholes. The size of the hole shall have a maximum dimension of 4-inches larger than the outside diameter of the pipe. The annular space shall be filled with dry-pack mortar.

**C      DATUM VERIFICATION**

The District uses the North American Vertical Datum of 1988 (NAVD 88) for vertical control. The Owner shall be responsible for verifying all existing elevations when making tie-ins regardless of data provided by the District.

--END OF SECTION--

**TECHNICAL SPECIFICATIONS  
FOR  
SEWER LATERALS**

**A GENERAL**

These specifications designate the requirements for furnishing and installation of sewer laterals.

Sewer laterals shall be constructed of the type and size and at the locations required and as approved by the District and in conformance with these specifications. The term "sewer lateral" is used in these specifications and on the plans to designate a branch sewer laid from a sanitary sewer main to a point on a street or public right-of-way or easement boundary from which sewer service to an individual building unit can be obtained through proper sewer extension by the property owner and shall be constructed according to the form, dimensions and details shown on the Standard Details.

**B MATERIALS AND WORKMANSHIP**

**B-1 MATERIALS**

Sewer laterals shall be of the same material as the main sewer line.

**B-2 SIZE OF PIPE**

Sewer laterals shall be not less than 4 inches internal diameter. Actual size of building sewers larger than 4 inches shall be determined by fixture unit requirements as per the current edition of the Uniform Plumbing Code.

**B-3 DEPTH OF PIPE**

Sewer laterals shall be placed at such depth to give a minimum of 48-inches of cover to the top of the bell at the property line or to edge of the easement. The minimum distance between the gutter flowline and the top of the sewer lateral shall be 3 feet.

**C INSTALLATION - SEWER LATERALS**

Sewer laterals and sanitary "wye" or "tee" branch fittings shall be of the diameter and of the form required and as approved by the District.

Each branch fitting shall have its barrel diameter equal to the diameter of the sanitary sewer main and the spur (or branch) diameter as necessary for connection to the sewer lateral. The spur pipe of branch fittings shall be inclined at an angle of 45 degrees from a horizontal line and shall be supported with compacted clean sand, crushed rock or other material approved by the District in accordance with the Standard Details. All branch fittings that are to be left unconnected shall be plugged with a stopper equal in diameter to the outside of the pipe barrel and affixed securely in place. The stopper shall be of the same material used for the laterals.

Sewer laterals shall join to branch fittings at the sanitary sewer main as set forth above by eighth bends. All sewer laterals shall be plugged with a stopper in the socket at the last joint of said sewer laterals which shall be securely jointed and shall lie approximately at the public right-of-way boundary and/or property line.

Insulated tracer wire shall be placed above all sewer laterals, tracer wire shall be 12-gauge minimum. Bring tracer wire up in valve boxes, meter boxes, etc. Coil wire in box with sufficient length to extend two feet above finish grade.

**C-1 LOCATION OF SEWER LATERALS**

The location of each sewer lateral shall be marked at its upper end by chiseling a letter "S" 1-1/2-inches high on the top of the curb. If the terminal point of the sewer lateral is more than 8 feet beyond the curb line or curb improvements do not exist, the Contractor or Owner shall furnish and install a wood stake at the end of the sewer lateral in conformance with the Standard Details.

**C-2 FITTING AT END OF SEWER LATERALS**

Branch fittings shall be installed at the end of sewer laterals and unconnected ends shall be plugged with stoppers as provided herein.

--END OF SECTION--



**TECHNICAL SPECIFICATIONS  
FOR  
CHEMICAL-RESISTANT COATINGS FOR MANHOLES**

**A GENERAL**

This section includes materials and installation of a chemical-resistant coating for new concrete manholes.

**B MATERIALS**

All manholes, wet wells, and/or other concrete appurtenance subject to corrosion from gas, vapors, or chemicals associated with raw sewage, shall be coated with one of the systems listed below.

**B-1 TYPE "B" COATING: POLYURETHANE**

Coating system shall be a two-component, minimum 100% solids, polyurethane, with primer. Characteristics shall be as follows:

Tensile Strength on Concrete: 2,500 psi (minimum) per ASTM D 412.

Flexibility: No effect bending 0.50 mm plate with 30-mil coating over 1/8-inch mandrel per ASTM D 1737 or no effect bending 180° over 1-inch mandrel with 15-mil coating per ASTM D 522.

Elongation: 50% (minimum) recoverable, per ASTM D 412.

Surface Hardness: 60 minimum, Shore "D" per ASTM D 2240.

Abrasion Resistance: Weight loss of 80 mg (maximum) on Taber abraser, CS-17 wheel, 1,000 grams, 1,000 cycles per ASTM D 4060.

**B-1A PRODUCT**

Product shall be Sancon 100 as manufactured by Sancon Engineering Inc.; Polibrid 670-S primer with 705 topcoat as manufactured by Polibrid Coatings, Inc. (Carboline); or equivalent.

**B-1B THICKNESS**

Apply prime coat and finish coats to give a total dry coating thickness of at least 125 mils.

**B-2 EPOXY COATING**

Coating system shall be a two part high build epoxy system composed of 100% solids epoxy resin, formulated for spray application. Product shall be installed according to manufacturer recommendations by experienced, trained technicians. Characteristics shall be as follows:

Tensile Strength: 6,000-psi per ASTM D 638

Flexural Strength: 10,000-psi per ASTM D 790

Compressive Strength: 10,000-psi per ASTM D 695

Tensile Elongation @ Break: 4.5%

Hardness: 80 minimum, Shore "D" pr ASTM D 2240

**B-2A PRODUCT**

Product shall be S-301 Epoxy Spray System as manufactured by Warren Environmental; Enviroline 222 as manufactured by Enviroline Group; or equivalent.

**B-2B THICKNESS**

Apply coating(s) to give a total dry coating thickness of at least 80 mils.

**C SURFACE PREPARATION AND APPLICATION**

The coating shall not be applied to the frame and cover, but shall extend up the grade rings (as required) and terminate at the junction with the frame and manhole concrete.

Surface preparation and application shall be per manufacturer's recommendations.

**D TESTING**

The Contractor, in the presence of the District, shall inspect each coat of primer and finish coating in accordance with ASTM D 4787 to determine integrity. Each coating application will be checked and deficiencies marked. After observing specified recoat time, apply additional coating materials over areas having any holidays or pinholes. After correction of deficiencies, the Contractor shall reinspect those areas to determine the acceptability of the additional coating. Each coating application must be to the satisfaction of the District prior to succeeding coating applications.

**E WARRANTY**

In accordance with Section 6-3 of the General Conditions, the Owner shall warranty the work for a period of five (5) years from the date the work was accepted by the District. The District will inspect the condition of the coating(s) prior to the end of the warranty period with an emphasis on the condition of the coating(s) at the crown of the pipe and the top of the manhole. Evidence of corrosion or abrasion of the coating, or other evidence of wear will result in the Owner repairing the work at no cost to the District.

The name and contact information for the sewer manhole coating applicator shall be permanently marked on the interior of the manhole, just inside the manhole cover.

--END OF SECTION--

**TECHNICAL SPECIFICATIONS  
FOR  
TESTING OF PVC SEWER PIPE**

**A TEST FOR DAMAGED OR DEFECTIVE PLASTIC SEWER PIPE IN PLACE**

Prior to the acceptance of any sewer line by the District, the contractor shall clean all lines with a Wayne-type sewer cleaning ball. Any stoppage, sand, dirt or foreign matter shall be removed from the lines. All cleaning and testing of sewer lines shall take place after all construction work is completed, up to but not including, the paving.

Following the permanent placement and densification of backfill and prior to the placing of permanent pavement, all main line pipe shall be cleaned to the District's satisfaction and then mandrelled to measure for obstructions (deflections, joint offsets, and lateral pipe intrusions). A rigid mandrel shall be pulled through the pipe by hand. The mandrel shall have a cross section equivalent to a circle having a diameter of at least 95% of the average inside diameter for PVC pipe. The minimum length of the circular portion of the mandrel shall be equal to the nominal diameter of the pipe.

Obstructions encountered by the mandrel shall be corrected by the Owner.

All material, equipment, and labor to perform the test shall be provided by the Owner and/or Contractor.

**B TEST FOR LEAKAGE AND INFILTRATION**

It is the intent of these specifications that the completed sewer pipes of all types, along with manholes and other appurtenances, shall be watertight.

Following the permanent placement and densification of backfill and prior to the placing of permanent pavement, each section of sewer between two successive manholes shall be tested for leakage and/or, at the option of the District, for infiltration. Where groundwater is encountered, the infiltration test shall be made.

Even though a section may have previously passed the leakage or infiltration test, each section of sewer shall be tested subsequent to the last backfill compacting operation in connection therewith, wherein, in the opinion of the District or Owner's Engineer, heavy compaction equipment used in any of the operations may have damaged or affected the required watertight integrity of the pipe, structure and appurtenances. The Owner or his Contractor shall furnish all material required for the tests and bear all costs in connection therewith. Tests shall be made in the presence of the Owner's Engineer.

If the leakage and/or infiltration rate, as shown by the tests specified herein, is greater than the amount specified, the pipe joints shall be repaired or, if necessary, the pipe shall be removed and relaid at the Owner's expense.

The sewer will not be considered acceptable until the leakage and/or infiltration rate, as determined by test, is less than the allowable.

Prior to testing, all service laterals shall be installed and shall be tested simultaneously.

## **B-1 LEAKAGE TEST**

The Owner may, at his option, air test or water test for leakage, except where the difference in elevation between the invert of the upper structure and the invert of the lower structure is more than 12 feet. In this instance, the air test shall be made.

Water Test Procedure: Each section of sanitary sewer between two successive structures shall be tested by closing the lower end of the sewer to be tested and the inlet sewer of the upper structure with plugs or stoppers and filling the pipe and structure with water to a point 5 feet above the invert of the open sewer in the upper structure or to a height of 12 feet above the invert of the sewer in the lower structure, whichever gives the least hydrostatic pressure on the lower structure.

The total leakage shall be the decrease in volume of water in the upper structure. The leakage shall not exceed 1.6 gallons per 100 feet per 4 hour test per inch diameter of sewer pipe being tested. The length of house connections shall not be used in computing the length of sewer main being tested.

If the leakage, as shown by the test, is greater than allowed, the pipe shall be overhauled and, if necessary, replaced and relaid until the joints and pipe shall hold satisfactory under this test. All tests must be completed before the street or trench is resurfaced, unless otherwise determined by the District. The Owner or his Contractor shall furnish all labor and materials for making the tests required at his own expense.

Air Test Procedure: Each section of sewer between two successive manholes shall be tested by plugging all pipe outlets with suitable test plugs. Air shall be slowly added until the internal pressure is raised to 4.0 pounds per square inch gage (psig). The compressor used to add air to the pipe shall have a blowoff valve set at 5 psig to ensure that at no time the internal pressure in the pipe exceeds 5 psig. The internal pressure of 4 psig shall be maintained for at least two minutes to allow the air temperature to stabilize, after which the air supply shall be disconnected and the pressure allowed to decrease to 3.5 psig. The time required for the internal air pressure to drop from 3.5 psig to 3.0 psig shall be measured and the results compared with the values calculated using the following formula:

$T = KL$ , Where T = time in seconds,

L = distance between successive manholes in feet, and

K = appropriate value from the following table (see table on next page).

<b>Pipe Diameter (inches)</b>	<b>Minimum Time (min:sec)</b>	<b>Length for Minimum Time</b>	<b>K Value</b>
8	3:47	298	0.760
10	4:43	239	1.19
12	5:40	199	1.71
14	6:27	180	2.15
16	7:29	160	2.81
18	8:30	133	3.85
20	9:59	100	5.99
24	10:34	100	6.34

If the pressure drop from 3.5 psig to 3.0 psig occurs in less time than the calculated values, the pipe shall be overhauled and, if necessary, replaced and relaid until the joints and pipe shall hold satisfactorily under this test.

**B-2 TEST FOR INFILTRATION**

If, in the construction of a section of the sewer between structures, groundwater is encountered, the end of the sewer at the upper structure shall be closed sufficiently to prevent the entrance of water and pumping of groundwater shall be discontinued for at least three days after which the section shall be tested for infiltration. The infiltration shall not exceed 1.6 gallons per 100 feet per 4 hour test per inch diameter of main line sewer being tested and does not include the length of house laterals entering that section. Where any infiltration in excess of this amount is discovered before completion and acceptance of the sewer, the sewer shall be immediately uncovered and the amount of infiltration reduced to a quantity within the specified amount of infiltration, before the sewer is accepted, at the expense of the Owner. Where any individual infiltration leaks are observed before completion and acceptance of the sewer, the sewer shall be immediately uncovered and the individual infiltration leaks shall be stopped, before the sewer is accepted, at the expense of the Owner. The Owner shall furnish all labor and materials for making the tests required at his own expense. All tests must be completed before street or trench is resurfaced, unless otherwise determined by the District.

**C TESTS FOR ALIGNMENT AND GRADE, AND DAMAGED OR DEFECTIVE PIPE IN PLACE**

After the pipe has been installed, backfilled to existing grade, tested for leakage and/or infiltration, manholes raised to grade and resurfaced, and prior to the placing of permanent pavement, the pipe shall be "balled" and

inspected with a closed circuited television system to test for alignment, grade, damaged or defective pipe in place, or any other type of faulty installation.

C-1. Perform balling from manhole to manhole with a sewer scrubbing ball of type and size to be approved by District in the presence of the Owner's Engineer and in conformance with General Condition 3-9 and 3-10. Should balling indicate any faulty installation of the pipe, repairs or replacements shall be made at the Owner's expense.

C-2. Closed circuited television (CCTV) inspection shall be performed to determine if the sanitary sewer was installed in accordance with District requirements. The inspection will be done one manhole section at a time and the flow in the section being inspected will be suitably controlled as specified in Technical Specifications for Connections to Existing Sewer Pipe. All CCTV inspections shall be performed in accordance with PACP Standards, unless specific exemptions from PACP Standards are obtained in advance from the District.

The television camera used for the inspection shall be one specifically designed and constructed for such inspection. Lighting for the camera shall be suitable to allow a clear picture of the entire periphery of the pipe. The camera shall be operative in 100% humidity conditions. The camera, television monitor, and other components of the video system shall be capable of producing picture quality to the satisfaction of the District.

The inspection video shall be in color and have a continuous graphic display of date, time, and footage in 0.1 foot increments. The system to be utilized on the project shall be approved by the District. The Contractor shall televise the pipeline during optimum low-flow level conditions as pre-approved by the District.

The camera shall be moved through the line in the direction of flow unless access restrictions require the use of a reverse setup, and shall be moved at a moderate rate, stopping when necessary to permit proper documentation of the sewer's condition. In no case will the television camera be pulled at a speed greater than 30 feet per minute. Manual winches, power winches, TV cable, and powered rewinds or other devices that do not obstruct the camera view or interfere with proper documentation of the sewer conditions shall be used to move the camera through the sewer line.

When manually operated winches are used to pull the television camera through the line, telephones or other suitable means of communication shall be set up between the two manholes of the section being inspected to insure good communications between members of the crew.

The importance of accurate distance measurements is emphasized. Measurement for location of defects shall be above ground by means of a meter device. Marking on the cable, or the like, which would require interpolation for depth of manhole, will not be allowed. Accuracy of the distance meter shall be checked by use of a walking meter,



roll-a-tape, or other suitable device, and the accuracy shall be satisfactory to the District. Unless otherwise approved by the District, distance measurements shall begin at the centerline of the upstream manhole.

Documentation of the television results shall include video disks, written reports, and a database file, as follows:

Post-construction video inspection disks shall be submitted to the District and shall become the District's property. All video inspection equipment utilized shall produce both single images with annotations (JPEG) and streaming video formatted files (MPEG) playable on a computer with Microsoft Windows® Media Player. Digital files shall be delivered to the District on either new, blank, high quality CD or DVD disks. An individual digital video file shall be recorded for each sewer segment. Each file shall be identified by its own unique video file name. Each video disk may contain as many video files as the disk permits. The disk shall also contain the individual written inspection report for each inspected sewer line on the disk in digital "PDF" format.

Each video disk submitted shall be accompanied with written inspection reports. The written reports shall include, but are not necessary limited to:

- Video File Name;
- Time and date of the inspection;
- Upstream manhole number;
- Downstream manhole number;
- Sewer size;
- Footage to the nearest 0.1 foot;
- Direction of televised inspection;
- Location of service connections (laterals) by feet from beginning manhole;
- Location of significant features such as grade breaks, pipe breaks, offset joints, cracking, change in pipe material, standing water, etc.;
- Each significant feature noted shall be evaluated and coded according to PACP standards.
- Include footage and description of beginning/ending of inspection.

One disk shall also contain all the inspection data for the project stored in standard Database Format (ACCESS) and all data fields shall conform to NASSCO standards. The database shall contain information that can be used to link each database entry to its related video (MPEG) and still image (JPEG) files.

If deficiencies are observed, the Owner will make the required corrections and re-video the pipeline prior to acceptance of the sewer system.

**D FINAL VIDEO INSPECTION**

Video inspection as described above shall also be performed after all installation has been completed, including backfilling, compacting, finished pavement and cleanup, and after all testing, balling, mandreling and flushing has been completed. If deficiencies are observed, the Owner will make the required corrections and re-video the pipeline prior to acceptance of the sewer system.

--End of Section--

**TECHNICAL SPECIFICATIONS  
FOR  
TRAFFIC REGULATION**

**A GENERAL**

This section describes procedures for traffic regulation and temporary steel plate bridging during construction in public streets and highways.

**A-1 STANDARD SPECIFICATIONS**

Wherever reference is made to the State Specifications and Plans, such reference shall mean the latest edition of the State of California, Business and Transportation Agency, Department of Transportation Standard Specifications and Plans, latest edition.

**B VEHICULAR TRAFFIC**

The Contractor shall provide safe and continuous passage for pedestrian and vehicular traffic at all times.

**B-1 TRAFFIC CONTROL PLAN**

The Contractor shall submit, not less than 14 working days prior to start of construction operations, a traffic control plan to San Luis Obispo County or California Department of Transportation for approval. Preparation of any additional traffic control plans or detail that may be required during the course of the work shall be the Owner's or Contractor's responsibility. No work shall begin involving or requiring alternate traffic control until a traffic control plan is approved by the appropriate authority.

**B-2 TRAFFIC CONTROL DEVICES AND SIGNS**

Furnish, construct, maintain, and remove detours, road closures, traffic signal equipment, lights, signs, barricades, fences, K-rail, flares, solar-powered flashing arrow signs, miscellaneous traffic devices, flagmen, drainage facilities, paving, and such other items and services as are necessary to adequately safeguard the public from hazard and inconvenience. All such work shall comply with the ordinances, directives, and regulations of authorities with jurisdiction over the public roads in which the construction takes place and over which detoured traffic is routed by the Contractor. After devices have been installed, the Contractor shall, at his own expense, maintain and keep them in good repair and working order until no longer required. The Contractor shall also pay the cost of replacing such devices that are lost or damaged, to such an extent as to require replacement, regardless of the cause of such loss or damage.

### **B-3 PLACEMENT OF TRAFFIC CONTROL DEVICES AND SIGNS**

The placement of construction signing, striping, barricades, and other traffic control devices used for handling traffic and public convenience shall conform to the latest edition of the State of California, Department of Transportation, "Manual of Traffic Controls for Construction and Maintenance Work Zones".

### **C TEMPORARY STEEL PLATE BRIDGING, WITH A NONSKID SURFACE**

When backfilling operations of an excavation in the traveled way, whether transverse or longitudinal, cannot be properly completed within a workday, provide steel plate bridging with a nonskid surface and shoring to preserve unobstructed traffic flow.

#### **C-1 PLATE DESIGN**

Design steel plate bridging for HS20-44 truck loading per Caltrans Bridge Design Specifications Manual. The Contractor may use standard steel plate with known coefficient of friction equal or exceeding 0.35.

### **D VEHICULAR TRAFFIC CONTROL**

Accomplish construction in phases by detouring traffic from its normal patterns along the route in approximately 1/2-mile intervals between major cross streets to form the construction zone. Restore traffic to normal patterns in each phase before proceeding to the next phase.

### **E PEDESTRIAN TRAFFIC CONTROL**

Maintain and delineate a minimum of one 4-foot-wide pedestrian walkway along each public street at all times during construction. Maintain existing pedestrian accesses at intersections at all times. When existing crosswalks are blocked by construction activity, install signs directing pedestrian traffic to the nearest alternative crosswalk.

### **F ACCESS TO ADJACENT PROPERTIES**

Maintain reasonable access from public streets to adjacent properties at all times during construction. Prior to restricting normal access from public streets to adjacent properties, notify each property owner or responsible person, informing him of the nature of the access restriction, the approximate duration of the restriction, and the best alternate access route for that particular property.

--END OF SECTION--

**TECHNICAL SPECIFICATIONS  
FOR  
CONCRETE CONSTRUCTION**

**A GENERAL**

These specifications designate the requirements for furnishing and installation of concrete.

**B CONCRETE**

**B-1 CLASS A**

Class A concrete shall contain not less than six sacks of Portland cement per cubic yard and have a minimum compressive strength of 3,000 psi in 28 days.

**B-2 CLASS B**

Class B concrete shall contain not less than five sacks of Portland cement per cubic yard and have a minimum compressive strength of 2,500 psi in 28 days.

**C REINFORCING**

Where reinforced concrete is required, reinforcing steel conforming to the applicable provisions of the State Specifications shall be furnished and installed.

--END OF SECTION--

**TECHNICAL SPECIFICATIONS  
FOR  
REMOVAL AND RESURFACING OF  
STREET PAVEMENT AND SURFACES**

**A GENERAL**

Street pavement and surfaces shall be removed and replaced in all areas of construction in conformance with details shown on the Plans and as specified herein. Resurfacing of existing pavement and surfaces damaged or removed in connection with the construction of improvements shall conform to the provisions of permits issued by the state, county, or other agency for the work within the rights-of-way of the respective agency.

**B EARTHWORK**

All earthwork shall conform to the provisions of the Technical Specifications for Earthwork of these Specifications.

**C PAVEMENT REMOVAL**

**C-1 GENERAL**

Street pavement or existing road surfacing shall be removed within the limits of all construction excavations prior to proceeding with excavation operations of any nature. Surplus material shall be removed as provided in the Technical Specifications for Earthwork. Prior to removal of existing surfacing, pavement cuts shall be made as shown on the Plans and/or specified herein. All pavement cuts shall be neat and straight along both sides of the trench and parallel to the alignment of the pipe to provide an unfractured and level pavement joint for bonding existing surfacing with pavement replacement. Where large irregular surfaces are removed, such trimming or cutting as hereinafter provided shall be parallel with roadway centerline or at right angles to the same. All cut edges shall provide clean, solid, vertical faces free from all loose material.

**C-2 PORTLAND CEMENT CONCRETE SURFACES**

Concrete pavement, including cross-gutters, curbs and gutters, sidewalks, driveways and concrete surfaces of whatever nature, shall be saw cut to minimum depth of 1-1/2 inches prior to removal in accordance with details shown on the Plans or as specified herein. Said saw cut shall be made at a point approximately 1 foot beyond the edge of the trench and/or excavation. The saw cut shall be made after backfilling, and the additional concrete pavement shall be removed and disposed of by the Contractor prior to resurfacing.

**C-3 ASPHALT CONCRETE PAVEMENT**

Streets and alleys surfaced with asphalt concrete pavement shall be initially cut by means of pneumatic pavement cutters or other approved equipment at the limits of the trench and/or excavation prior to removal of surfacing. After backfilling the excavation, asphalt concrete pavement shall be saw cut to a minimum depth of 4 inches at a point not less than 9 inches outside the limits of excavation or the previous pavement cut (made by pneumatic tools),

which ever limits are the greater. The additional surfacing so cut shall be removed and disposed of by the Contractor prior to resurfacing.

#### **C-4 ROAD MIXED SURFACING**

Streets and alleys surfaced with road mixed surfacing shall be cut at the limits of the trench and/or excavation prior to removal of existing surfacing. Cuts may be made with pneumatic tools or other approved equipment. The extra trimming width made by saw cuts prior to resurfacing asphalt concrete pavement will not be required.

#### **D RESURFACING**

In all streets or alleys in which the surface is removed, broken or damaged by equipment or in which the ground has caved in or settled due to the installation of the improvements, the surface shall be restored to the original grade and crown section. Where the street has been improved with roadway surface, base course, curb, sidewalk or gutter, trenches or damaged sections shall be restored with the type of improvement conforming to that which existed prior to the work. Prior to resurfacing, the existing surfacing shall be removed as provided above. All broken and jagged edges of the trench shall be straight. If during the initial removal of the existing pavement a method of removal was used which disturbed the adjoining pavement or if during general construction the adjacent pavement was disturbed, then this adjoining pavement must also be removed and replaced. Disturbed or undermined cement treated base shall be removed and replaced with its equivalent aggregate base, and asphalt concrete paving above the cement treated base shall be sawed in a straight line and replaced in kind.

All work shall match the appearance of the existing improvements and finished pavement shall not deviate from existing grade by more than 1/8 inch in 10 feet and shall be free from ruts, depressions, and irregularities. Asphaltic paint binder shall be applied to the vertical faces of all asphaltic concrete pavement against which the pavement replacement materials are to be placed. The completed surface, when ready for acceptance, shall be thoroughly compacted, true to grade and cross section and shall be free from ruts, depressions, and irregularities. Where the trench line is approximately parallel with the traveled way, the pavement shall be brought to the final grade with a Barber-Green paving machine or approved equivalent. The resulting edge of contact between the new and existing pavement on each side shall parallel the existing trench and be a straight and neat join line. New pavement shall not lap over existing pavement.

In the event that it is necessary to construct a temporary patch, the materials used shall be approved by the agency having jurisdiction. A permanent patch shall be constructed as soon as practical.

#### **E TEMPORARY RESURFACING**

In the event that it is necessary to construct a temporary patch, the materials used shall be approved by the agency having jurisdiction. A permanent patch shall be constructed as soon as practical.

--End of Section--



**TECHNICAL SPECIFICATIONS  
FOR  
USE OF COMPLETED FACILITIES**

The District shall have the right upon ten (10) days written notice to the Owner and his Surety to take possession of and use any completed or partially completed portion of the work notwithstanding that the time for completing the entire work may not have expired, but such taking possession and use and assumption of maintenance of any portion of the work shall not be deemed an acceptance of any work. It is the intent of this section to provide for the District placing into operation portions of the facilities as the work progresses.

When any section of the improvements has been completed in all respects, except for trench resurfacing, the District may so notify the Owner and his Surety in writing as provided herein. After such notice has been given, the District shall have the right to place such section of the facility into service and to operate same. The Owner will be relieved of the duty of maintaining and protecting said portion of the work except for any resurfacing, if required. When resurfacing is not required, the Owner shall be relieved of the responsibility and duty of maintaining and protecting portions of the roadway only after receiving written notice from the District.

However, nothing in this section shall be construed as relieving the Owner of the full responsibility for making good defective work or materials as specified in the General Conditions.

--END OF SECTION--

**TECHNICAL SPECIFICATIONS  
FOR  
CLEAN-UP**

During the progress of the work, the work area shall be kept free of any accumulation of rubbish and debris. Upon completion of the work and before Acceptance of the completed facility by the District, all unused materials, rubbish, concrete forms, surplus excavated material and other materials or equipment shall be removed from the work area.

If during the progress of the work any improvements, such as, fences, lawns, shrubs or other vegetation, whether on private or public property are damaged, they shall be restored to a condition equivalent to that which existed before work started before acceptance of the completed facilities by the District.

**A SEWER MAIN CLEANING**

Prior to the acceptance of any sewer line by the District, the contractor shall clean all lines with a Wayne-type sewer cleaning ball. Any stoppage, dirt or foreign matter shall be removed from the lines. All cleaning and testing of sewer lines shall take place after all construction work is completed, up to but not including, the paving. The system will be inspected after paving is completed and any damage to the system during paving and cleanup will be corrected before approval.

**B WATER MAIN CLEANING**

Prior to the acceptance of any water line by the District, the contractor shall flush, disinfect, and test the water line. Flushing, disinfecting, and testing of water lines shall take place after all construction work is completed, up to but not including, the paving. The system will be inspected after final paving is completed and any damage to the system during final paving and cleanup will be corrected before approval.

--END OF SECTION--

# Standard Drawings

---

# Table of Contents

## Standard Drawings

---

<b>STANDARD WATER NOTES .....</b>	<b>W-1</b>
<b>WATER PIPE BEDDING BACKFILL DETAILS.....</b>	<b>W-2</b>
<b>VALVE BOX ASSEMBLY .....</b>	<b>W-3</b>
<b>TYPICAL THRUST BLOCK DETAILS.....</b>	<b>W-4</b>
<b>STANDARD ANCHOR BLOCK DETAIL .....</b>	<b>W-5</b>
<b>FIRE HYDRANT ASSEMBLY .....</b>	<b>W-6</b>
<b>BOLLARD/BARRICADES.....</b>	<b>W-7</b>
<b>¾" &amp; 1" STANDARD WATER SERVICES .....</b>	<b>W-8</b>
<b>1" WATER SERVICE LINE AND 1 " METER IN SINGLE METER BOX FOR RESIDENCES WITH FIRE SPRINKLERS.....</b>	<b>W-8A</b>
<b>1" WATER SERVICE LINE AND 1 " METER IN DUAL METER BOXES FOR RESIDENCES WITH FIRE SPRINKLERS.....</b>	<b>W-8B</b>
<b>1-1/2" &amp; 2" STANDARD WATER SERVICES .....</b>	<b>W-9</b>
<b>STANDARD LARGE DIAMETER WATER METER.....</b>	<b>W-10</b>
<b>4" MANIFOLD WATER SERVICE .....</b>	<b>W-11</b>
<b>DOUBLE CHECK DETECTOR BACKFLOW PREVENTOR 4" THRU 12" .....</b>	<b>W-12</b>
<b>DOUBLE CHECK DETECTOR BACKFLOW PREVENTOR LESS THAN 4" .....</b>	<b>W-12A</b>
<b>REDUCED PRESSURE PRINCIPLE BACKFLOW PREVENTOR 4" THRU 12" .....</b>	<b>W-13</b>
<b>REDUCED PRESSURE PRINCIPLE BACKFLOW PREVENTOR LESS THAN 4" .....</b>	<b>W-13A</b>
<b>BLOWOFF ASSEMBLY .....</b>	<b>W-14</b>
<b>COMBINATION AIR RELEASE VALVE ASSEMBLY .....</b>	<b>W-15</b>
<b>SAMPLE STATION .....</b>	<b>W-16</b>

<b>STANDARD SEWER NOTES .....</b>	<b>S-1</b>
<b>SEWER PIPE BEDDING AND BACKFILL DETAILS.....</b>	<b>S-2</b>
<b>48" AND 60" I.D. STANDARD MANHOLE.....</b>	<b>S-3</b>
<b>MANHOLE FRAME AND COVER.....</b>	<b>S-4</b>
<b>MANHOLE – DROP INLET .....</b>	<b>S-5</b>
<b>TYPICAL SEWER LATERAL .....</b>	<b>S-6</b>
<b>TYPICAL HOUSE CONNECTION.....</b>	<b>S-7</b>
<b>INLINE CLEANOUT .....</b>	<b>S-8</b>
<b>END OF LINE CLEANOUT .....</b>	<b>S-9</b>
<b>SEWER LATERAL CHIMNEY.....</b>	<b>S-10</b>
<b>TYPICAL DUPLEX SEWAGE LIFT STATION.....</b>	<b>S-11</b>

**WATER NOTES**

1. THE WATER FACILITIES TO BE DEDICATED TO THE NCSD (DISTRICT) SHALL BE CONSTRUCTED IN ACCORDANCE WITH THE CURRENT NCSD STANDARD SPECIFICATIONS FOR WATER AND SEWER SYSTEM IMPROVEMENTS. THE OMISSION OF ANY CURRENT STANDARD DETAIL DOES NOT RELIEVE THE CONTRACTOR FROM THIS REQUIREMENT.
2. THE DISTRICT SHALL BE NOTIFIED AT LEAST SEVEN (7) WORKING DAYS PRIOR TO START OF CONSTRUCTION. TELEPHONE (805) 939-1133. CONSTRUCTION WILL NOT TAKE PLACE ON WEEKENDS UNLESS SPECIFICALLY APPROVED BY DISTRICT. A PRECONSTRUCTION MEETING IS REQUIRED IN ACCORDANCE WITH DISTRICT STANDARDS GENERAL CONDITIONS SECTION 3.6.
3. THE CONSTRUCTION PLANS MUST BE APPROVED BY THE DISTRICT PRIOR TO THE START OF ANY WATER FACILITIES CONSTRUCTION. TWO (2) SETS OF APPROVED PLANS SHALL BE FURNISHED TO THE DISTRICT. PRIOR TO DISTRICT APPROVAL, THE PLANS MUST BE SIGNED BY A CALIFORNIA REGISTERED CIVIL ENGINEER. ALL UTILITIES SHALL APPROVE PLANS PRIOR TO NCSD.
4. ALL PIPE, FITTINGS, MATERIALS, AND INSTALLATION SHALL CONFORM TO THE LATEST EDITIONS OF THE AWWA SPECIFICATIONS.
5. PRIOR TO ACCEPTANCE OF THE WATER FACILITIES, ALL NECESSARY EASEMENT DOCUMENTS SHALL BE PROPERLY EXECUTED AND FURNISHED TO THE DISTRICT FOR BOARD APPROVAL PRIOR TO RECORDING.
6. WATER MAINS SHALL BE INSTALLED 5-FEET FROM THE FACE OF CURB UNLESS OTHERWISE INDICATED ON THE PLANS.
7. ALL WATER SERVICES SHALL BE METERED. DISTRICT EMPLOYEES WILL INSTALL METERS.
8. CONTRACTORS WILL COORDINATE ALL TIE-INS OF NEW WATER MAINS TO EXISTING WATER MAINS WITH THE DISTRICT TO MINIMIZE SERVICE INTERRUPTIONS. PROVIDE AT LEAST 2 WORKING DAYS NOTICE PRIOR TO CONSTRUCTION.
9. THE WATER SYSTEM, INCLUDING LATERALS, SHALL BE HYDROSTATICALLY TESTED PRIOR TO PLACING STREET PAVEMENT.
10. VALVES SHALL BE FLANGE CONNECTED TO FITTINGS WHEN LOCATED ADJACENT TO FITTINGS.
11. WATER LINES SHALL HAVE A MINIMUM COVER OF 36 INCHES.
12. FITTINGS SHALL BE FLANGED OR MECHANICAL JOINTS.
13. CONTRACTOR SHALL ADJUST VALVE BOXES, FIRE HYDRANT BREAK-OFF FLANGES, METER BOXES, ETC. TO SUBDIVISION FINISH GRADES AFTER CURBS AND GUTTERS, SIDEWALKS, AND STREETS HAVE BEEN CONSTRUCTED AT NO COST TO DISTRICT.
14. WHERE FIRE HYDRANTS ARE INSTALLED OR UP GRADED, THE CONTRACTOR SHALL INSTALL REFLECTORIZED, RAISED PAVEMENT MARKERS (STIMSONITE HYDRANT MARKERS), ALSO COMMONLY CALLED "BLUE DOTS". A TWO PART EPOXY ADHESIVE SHALL BE USED TO INSTALL THE MARKERS. ONE MARKER SHALL BE INSTALLED PERPENDICULARLY OPPOSITE EACH FIRE HYDRANT, APPROXIMATELY 6-INCHES OFFSET FROM THE CENTERLINE OF THE STREET ON THE HYDRANT SIDE OF THE STREET.
15. SERVICES THAT DO NOT COME STRAIGHT OFF THE MAIN ARE TO HAVE TAPE MARKED "CAUTION WATER LINE BELOW". TAPE TO BE INSTALLED 15-INCHES ABOVE THE SERVICE.
16. FIRE HYDRANTS, METER BOXES AND BLOWOFFS SHALL BE LOCATED NO CLOSER THAN 5-FEET FROM BEGINNING OF CURB RETURN, DRIVEWAY OR ANY OTHER UTILITY.
17. DURING CONSTRUCTION OF THE IMPROVEMENTS, THE OWNER'S ENGINEER SHALL NOTE DEVIATIONS FROM THE PLANS ON A SET OF PLANS SPECIFICALLY SET ASIDE FOR THIS PURPOSE. ANY CHANGES SHALL BE MADE ON THE ORIGINALS OF THE PLANS WITH A SUITABLE NOTE ON EACH SHEET STATING THAT THE ORIGINALS ARE THE "RECORD DRAWINGS".
18. UPON COMPLETION OF CONSTRUCTION, ONE COMPLETE SET OF RECORD DRAWINGS, ORIGINAL PLOTS ON MYLAR, ALONG WITH ELECTRONIC (AUTOCAD DWG.) FILES SHALL BE FURNISHED TO THE DISTRICT.
19. WORK SHALL BE DONE IN ACCORDANCE WITH THE APPROPRIATE ENCROACHMENT PERMITS.
20. DISINFECT PIPELINES PER DISTRICT STANDARDS - DO NOT USE TABLETS.

		<b>NIPOMO COMMUNITY SERVICES DISTRICT</b>	
		<b>STANDARD WATER NOTES</b>	
2010	MODIFY NOTE #1		
DATE	REVISION	DATE DRAWN MARCH 2008	SHEET NO. <b>W-1</b>

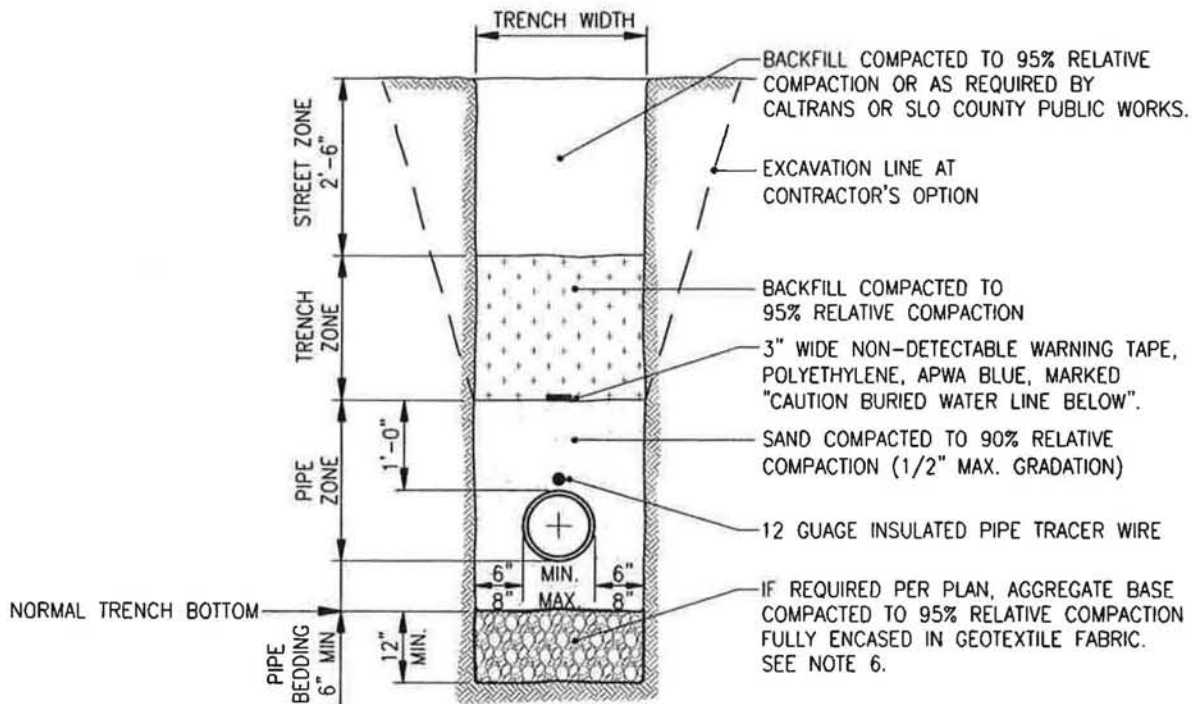

**NOTES:**

1. SAND SHALL BE PER STANDARD SPECIFICATIONS FOR EARTHWORK.
2. SEE STANDARD SPECIFICATIONS FOR EARTHWORK IF TRENCH WIDTH EXCEEDS THE MAXIMUM SHOWN ON THIS DRAWING.
3. STREET ZONE TO BE COMPACTED TO 95% RELATIVE COMPACTION PER (ASTM D-1557, 5 LAYER). SEE TECHNICAL SPECIFICATIONS FOR EARTHWORK.
4. SEE STREET IMPROVEMENT PLANS (IF APPLICABLE) FOR PAVING REQUIREMENTS.
5. MINIMUM COVER OVER ALL DISTRIBUTION MAINS TO BE 3'-0" AS MEASURED FROM THE FINISHED GRADE.
6. IF REQUIRED DUE TO UNSUITABLE SUBGRADE MATERIAL, PLACE AT LEAST 12" OF NO. 67 CRUSHED AGGREGATE COMPACTED TO 95% RELATIVE COMPACTION FULLY ENCASED IN POLYPROPYLENE, NEEDLE-PUNCHED, NON-WOVEN GEOTEXTILE FABIC, MIRAFI S600, GEOTEX NW-601 OR EQUAL.

		<b>NIPOMO COMMUNITY SERVICES DISTRICT</b>	
		<b>WATER PIPE BEDDING AND BACKFILL DETAILS</b>	
03/11	REVISE BACKFILL REQUIREMENTS	DATE DRAWN	SHEET NO.
DATE	REVISION	MARCH 2008	<b>W-2</b>



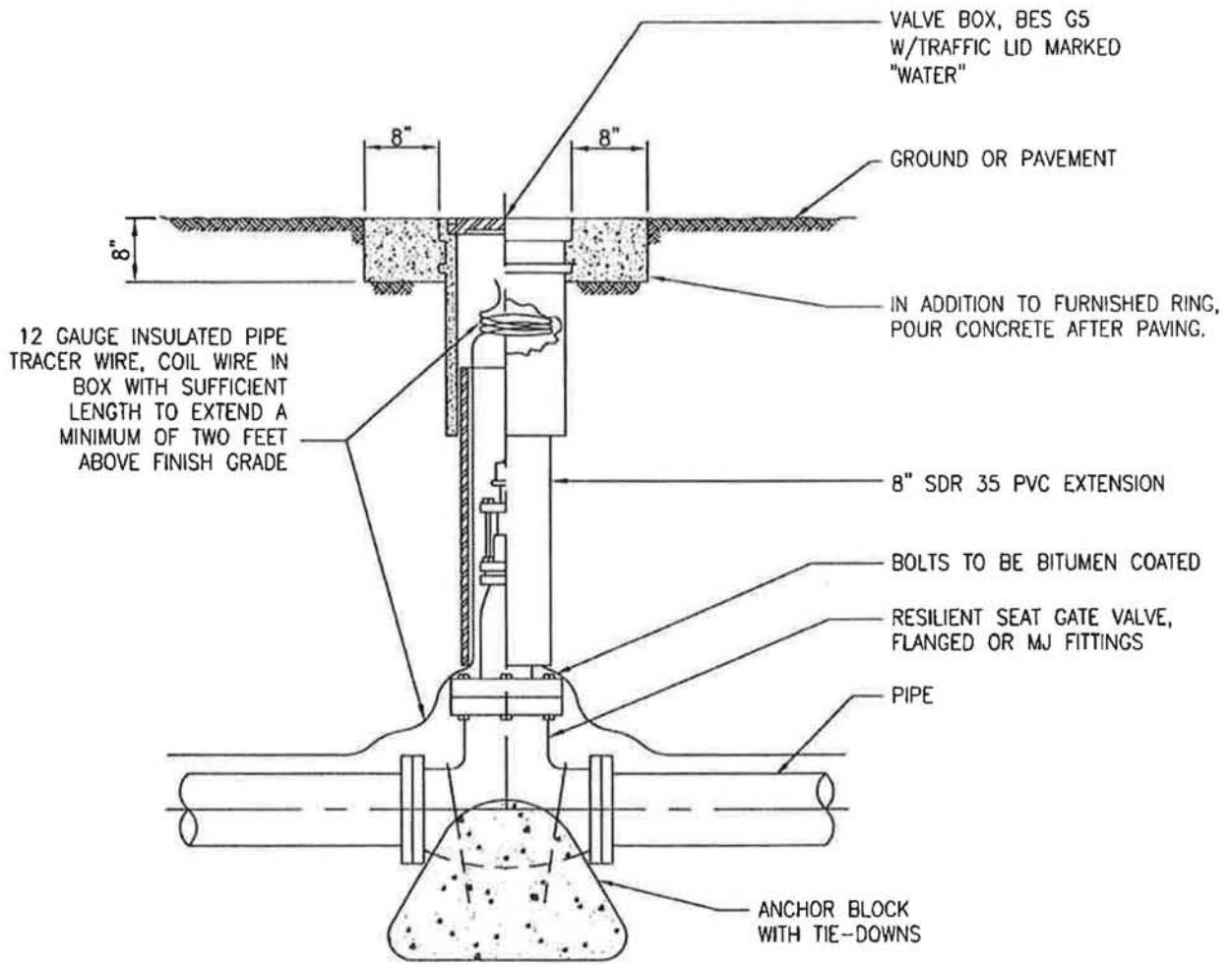

SECTION - ELEVATION

NOTE:  
WHEN VALVE BOX IS USED FOR  
SEWER APPURTENANCE, THE LID  
SHALL BE MARKED "SEWER".

		NIPOMO COMMUNITY SERVICES DISTRICT	
		VALVE BOX ASSEMBLY	
DATE	REVISION	DATE DRAWN MARCH 2008	SHEET NO. W-3

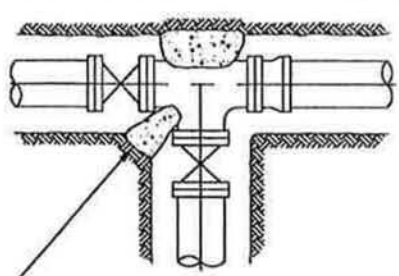

CONDITION 1  
(OUTLET OR FIRE HYDRANT)

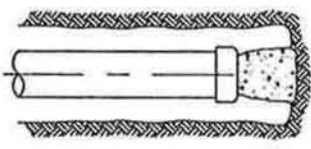

CONDITION 4  
(END CAP)

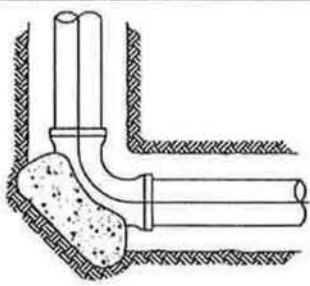

CONDITION 2  
(ANGLE = 90°)

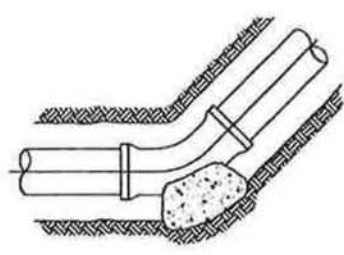

CONDITION 3  
(ANGLE = 45°)

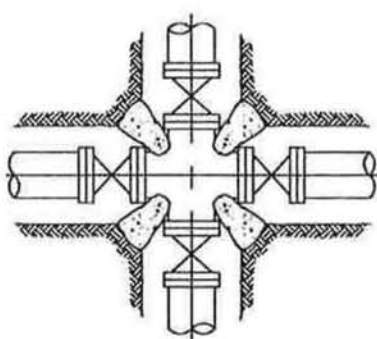

CONDITION 5  
(MAINLINE CROSS)

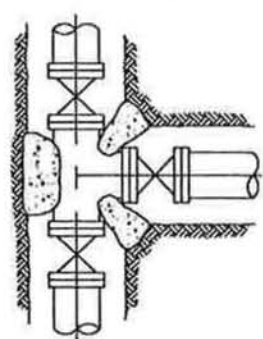

CONDITION 6  
(MAINLINE TEE)

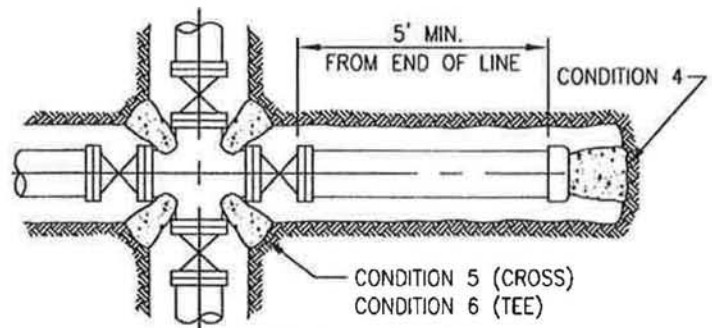

CROSS OR TEE AT END OF LINE

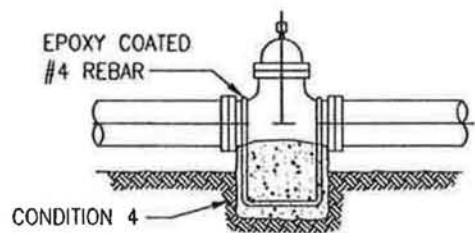

ANCHOR FOR IN LINE VALVES

THRUST BLOCK BEARING AREA IN SQ. FT.						
PIPE SIZE	CONDITION					
	1	2	3	4	5	6
6"	5.0	7.0	4.0	5.0	3.5 EACH	3.5 EACH
8"	8.5	12.0	6.5	8.5	6.0 EACH	6.0 EACH
10"	13.0	18.5	10.0	13.0	9.0 EACH	9.0 EACH
12"	18.5	26.0	14.0	18.5	13.0 EACH	13.0 EACH

BASED ON 1500 P.S.F., 200 P.S.I. TEST PROCEDURE

NOTES:

1. SIZE THRUST BLOCK ACCORDING TO THE LARGEST OUTLET DIAMETER ON TEE OR CROSS.
2. ALL THRUST BLOCK BEARING FACES SHALL BE POURED AGAINST UNDISTURBED SOIL OR APPROVED COMPACTED MATERIAL.
3. SEE SPECIFICATIONS FOR CONCRETE REQUIREMENTS.

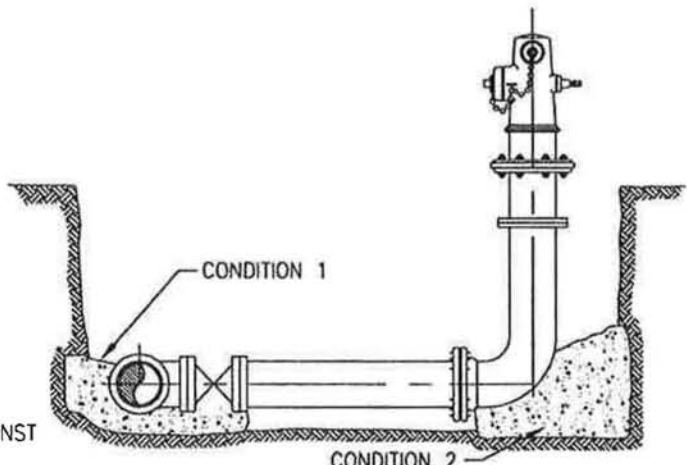

FIRE HYDRANT

		<b>NIPOMO COMMUNITY SERVICES DISTRICT</b>	
		<b>TYPICAL THRUST BLOCK DETAILS</b>	
DATE	REVISION	DATE DRAWN MARCH 2008	SHEET NO. W-4

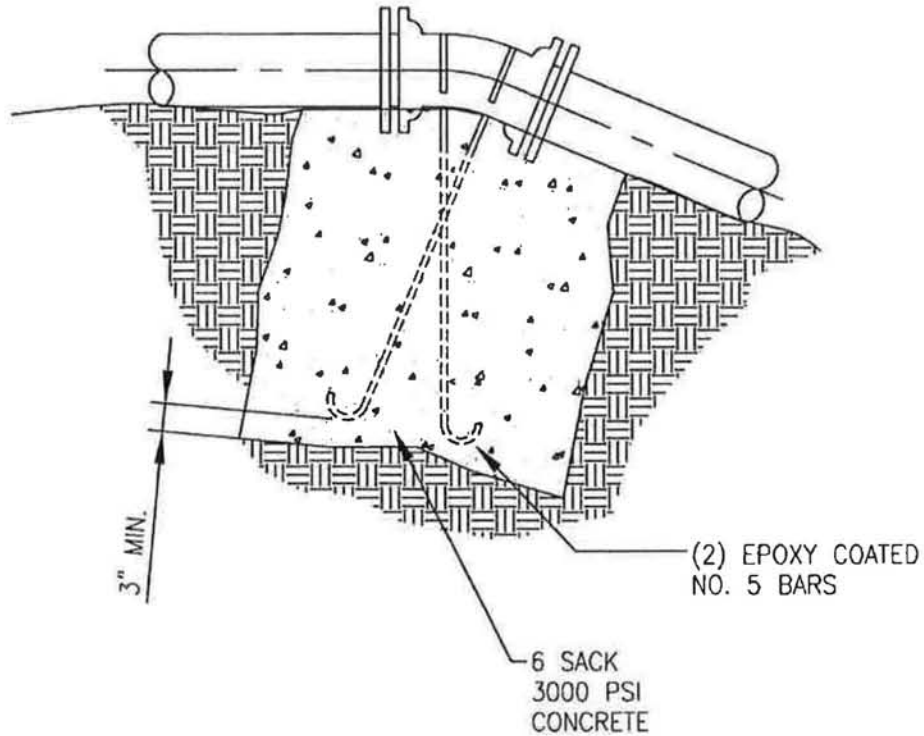

GENERAL NOTES:

1. CONCRETE BLOCK SHOULD BE APPROXIMATELY EQUAL IN ALL DIMENSIONS.
2. ALL BOLTED FLANGED ITEMS SHALL HAVE 30 MIL PLASTIC WRAP AND TAPED COVERING BOLTS AND FITTINGS.

CONCRETE VOLUME			
SIZE	11-1\4' BEND	22-1\2' BEND	45' BEND
12"	1 YD	3 YDS	6 YDS
10"	1 YD	2 YDS	4 YDS
8"	0.5 YD	1 YD	2 YDS

		NIPOMO COMMUNITY SERVICES DISTRICT	
		STANDARD ANCHOR BLOCK DETAIL	
DATE	REVISION	DATE DRAWN MARCH 2008	SHEET NO. W-5

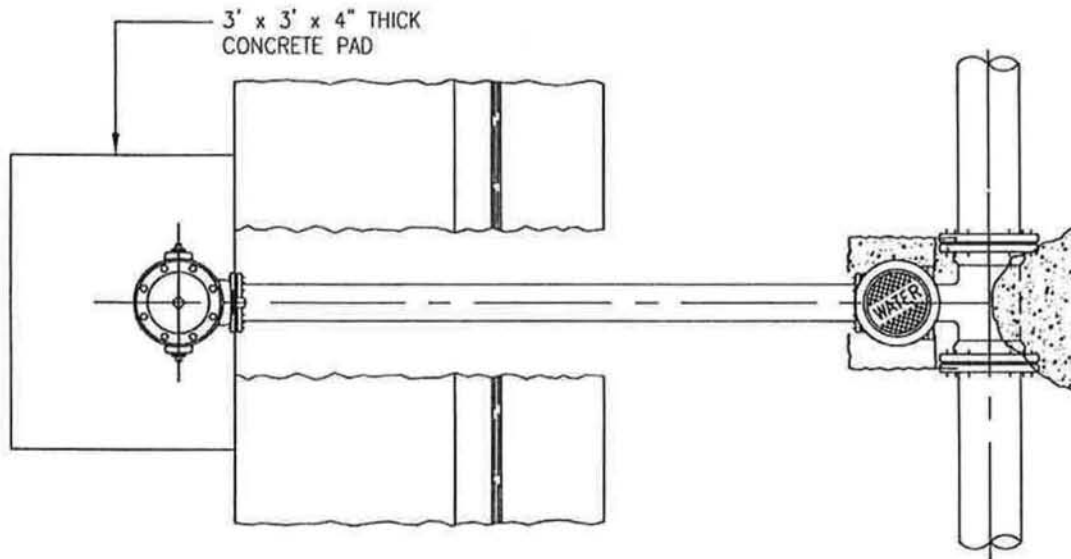

PLAN

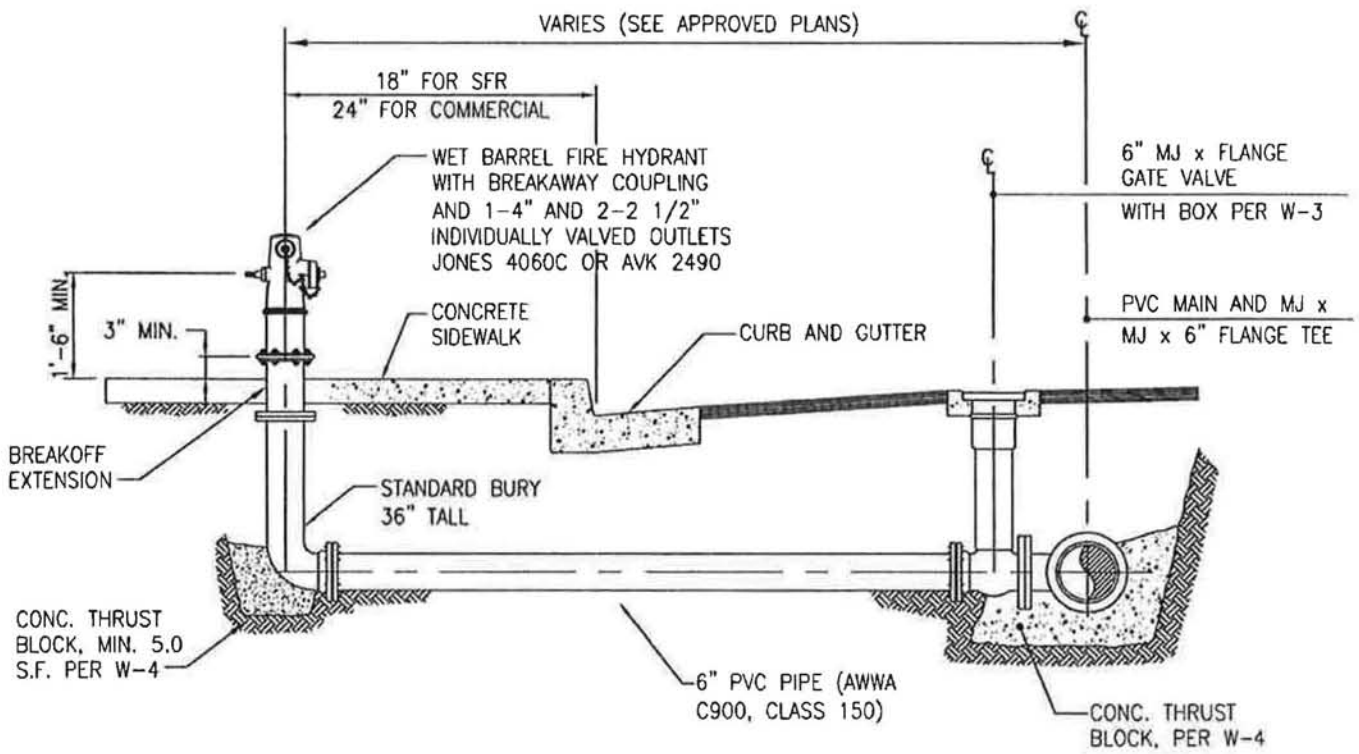

ELEVATION

		NIPOMO COMMUNITY SERVICES DISTRICT	
		FIRE HYDRANT ASSEMBLY	
DATE	REVISION	DATE DRAWN MARCH 2008	SHEET NO. W-6

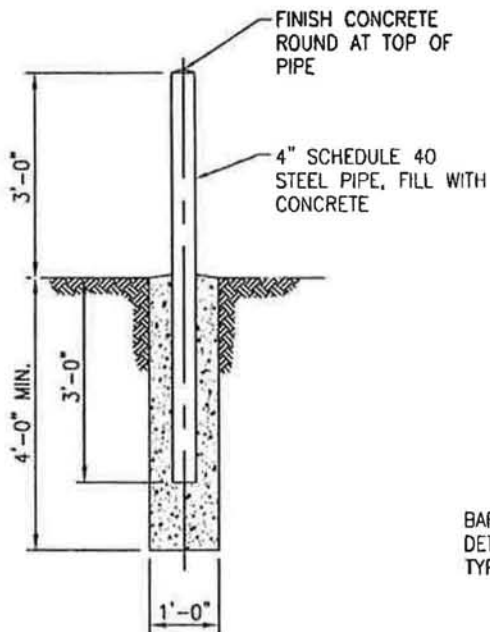

BOLLARD/BARRICADE  
DETAIL

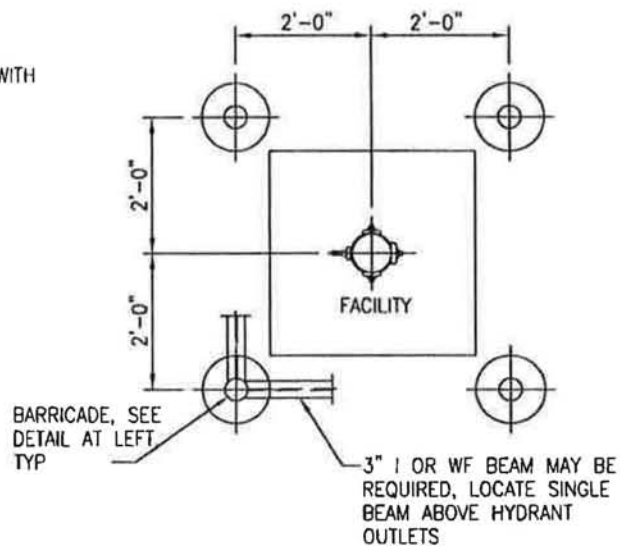

BOLLARD/BARRICADE  
PLAN

NOTES:

1. EXACT LOCATION OF BARRICADES MAY BE CHANGED BY THE DISTRICT IN THE FIELD.
2. SEE APPROVED PLANS FOR NUMBER OF BARRICADES TO BE USED AND FOR BRACES, IF REQUIRED.
3. THE EXTERIOR OF THE ABOVE GROUND PORTION OF THE BARRICADE SHALL BE PAINTED WITH TWO COATS OF DEVOE BAR-RUST 233H EPOXY COATING AND TWO COATS OF DEVOE NO. 379 DEVTHANE (MEDIUM YELLOW).
4. FOR SAFETY, BARRICADES SHALL NOT BE INSTALLED INSIDE THE CLEAR ZONE OF A ROADWAY AS DEFINED BY CALTRANS.

		NIPOMO COMMUNITY SERVICES DISTRICT	
		BOLLARD/BARRICADES	
DATE	REVISION	DATE DRAWN MARCH 2008	SHEET NO. W-7

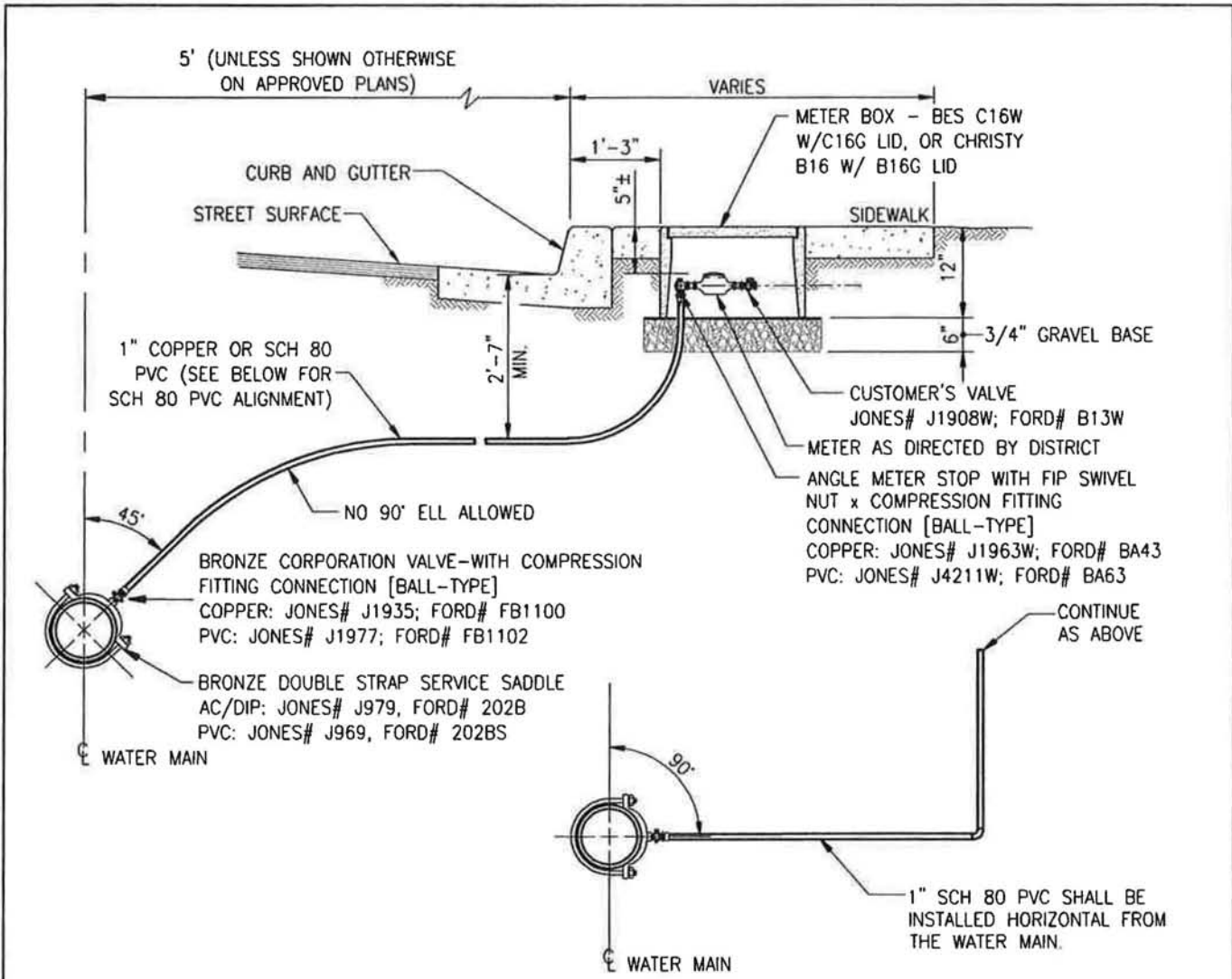

**GENERAL NOTES:**

1. SIZE OF THE SERVICE MUST BE APPROVED BY THE DISTRICT, MINIMUM SHALL BE 1-INCH SERVICE.
2. THE WATER SERVICE SHALL EXTEND PERPENDICULAR TO THE CENTERLINE OF THE STREET FROM THE WATER MAIN TO THE METER STOP.
3. METER BOXES SHALL BE CONSTRUCTED IMMEDIATELY BEHIND THE SIDEWALK WHERE SIDEWALKS ARE ADJACENT TO CURB.
4. IF METER BOX IS LOCATED ON A SLOPE NEXT TO A CURB OR SIDEWALK, A PROTECTIVE RETAINING WALL SHALL BE CONSTRUCTED.
5. CORPORATION VALVE TAP SHALL HAVE A SERVICE SADDLE AND SHALL BE MADE AS SPECIFIED BY THE PIPE MANUFACTURER'S INSTALLATION GUIDE. ALL DRY TAPS SHALL BE MADE WITH MACHINE WITH GUIDE OR PILOT FOR TAP. (DIRECT TAPS WILL NOT BE ALLOWED)
6. PROVIDE 12 GAUGE INSULATED TRACER WIRE ALONG EACH SERVICE OF SUFFICIENT LENGTH TO EXTEND INTO METER BOX AND A MINIMUM OF 24-INCHES ABOVE FINISH GRADE. COIL NEATLY INSIDE BOX.
7. SERVICE FOR PARCELS 10,000 SF OR LESS REQUIRE A 3/4" x 1" REDUCING ANGLE STOP OR A REDUCING FITTING.

		<b>NIPOMO COMMUNITY SERVICES DISTRICT</b>	
		<b>3/4" &amp; 1" STANDARD WATER SERVICES</b>	
03/11	ADD MODEL NUMBERS		
DATE	REVISION	DATE DRAWN MARCH 2008	SHEET NO. <b>W-8</b>

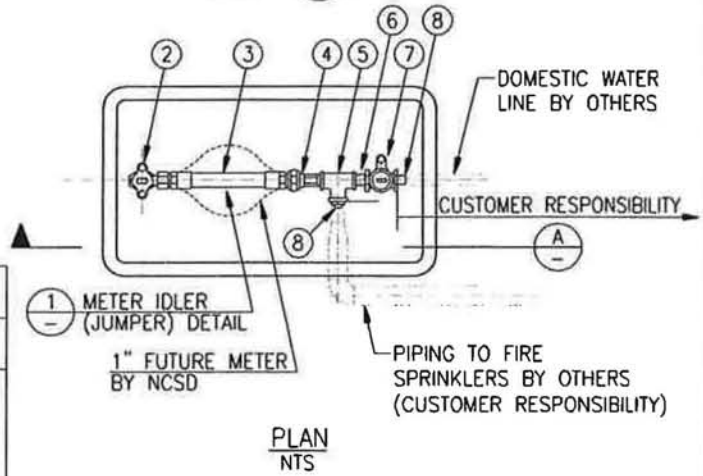
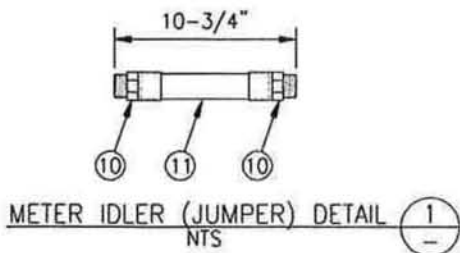
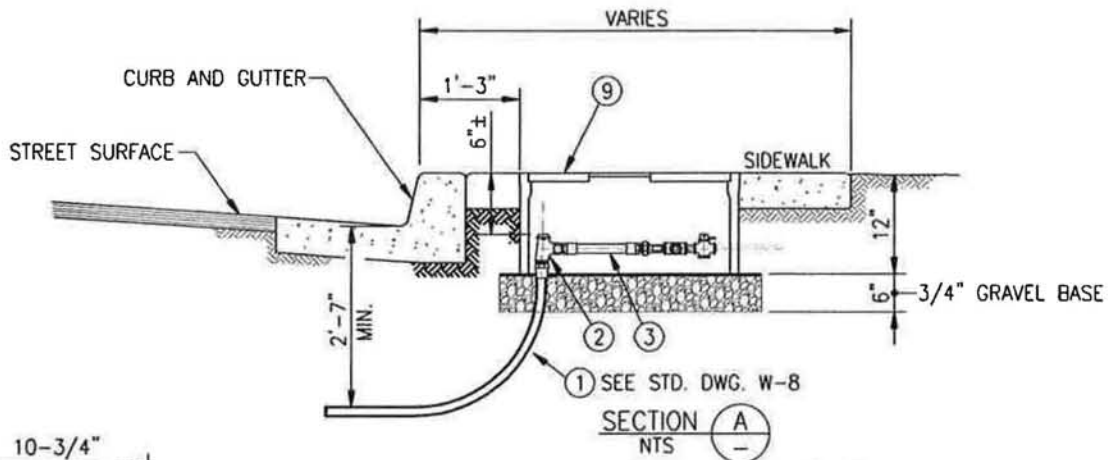

ITEM	DESCRIPTION
1.	1" COPPER OR SCH 80 PVC SERVICE LINE.
2.	ANGLE METER STOP WITH LOCK WINGS AND FIP SWIVEL NUT x COMPRESSION FITTING CONNECTION [BALL-TYPE]. COPPER: FORD #BA43, JONES #J1963W; PVC: FORD #BA63, JONES #J4211W.
3.	1-1/4" PVC IDLER (JUMPER). SEE METER IDLER (JUMPER) DETAIL ABOVE.
4.	1" x 2-5/8" STRAIGHT METER COUPLING WITH 1" MIP.
5.	1" BRASS TEE.
6.	1" CLOSE BRASS NIPPLE.
7.	CUSTOMER'S VALVE: (F.I.P. x F.I.P.) BALL VALVE CURB STOP WITH LOCK WING. JONES #J1900W; FORD #B11W.
8.	1" BRASS PLUG (2).
9.	METER BOX: BES C36 METER BOX WITH C36G LID OR CHRISTY B36 WITH FL36GUC107 LID.
10.	1-1/4" SLIP x MIP PVC ADAPTER.
11.	1-1/4" SCHEDULE 40 PVC PIPE.

**GENERAL NOTES:**

1. SEE STANDARD DRAWING W-8 FOR METER AND SERVICE LINE LOCATION AND CLEARANCE REQUIREMENTS.
2. ALL ITEMS LISTED TO BE INSTALLED BY WATER MAIN CONTRACTOR.
3. ANY SEALS OR LOCKS PLACED ON A CLOSED ANGLE METER STOP OR CURB STOP SHALL NOT BE REMOVED EXCEPT BY NCS.
4. METER BOXES SHALL BE INSTALLED ON COMPACTED MATERIAL.
5. IDLER (JUMPER) SHALL BE INSTALLED WITH TWO METER WASHERS.
6. METER BOX SHALL BE LOCATED SUCH THAT CENTER OF READING LID OPENING IS DIRECTLY ABOVE CENTER OF METER IDLER.

DATE	REVISION

**NIPOMO  
COMMUNITY SERVICES DISTRICT  
1" SERVICE LINE AND 1" METER IN SINGLE METER  
BOX FOR RESIDENCES WITH FIRE SPRINKLERS**

DATE DRAWN  
MARCH 2011

SHEET NO.  
**W-8A**



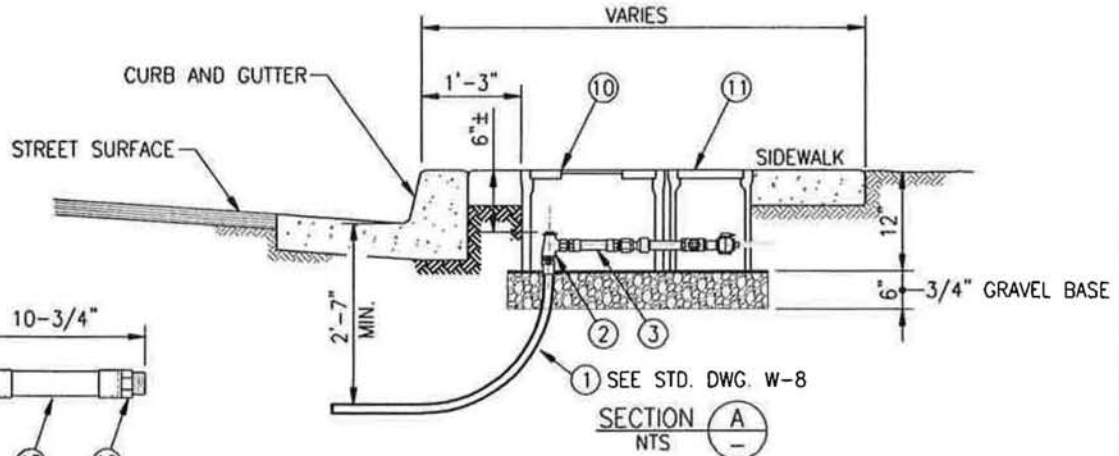

METER IDLER (JUMPER) DETAIL (1) NTS

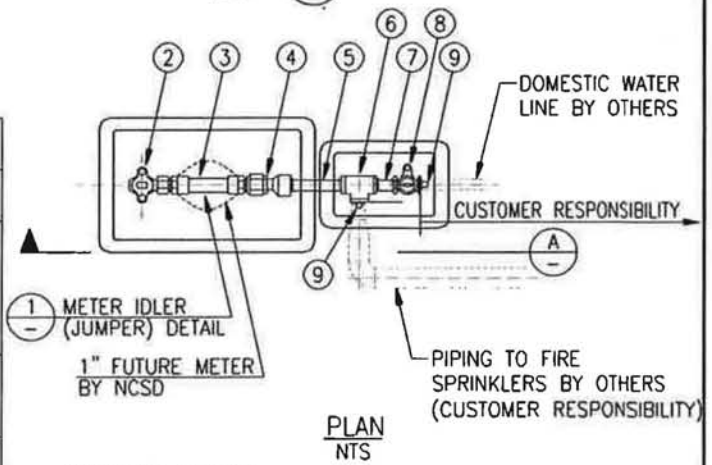

(1) METER IDLER (JUMPER) DETAIL NTS

PLAN NTS

ITEM	DESCRIPTION
1.	1" COPPER OR SCH 80 PVC SERVICE LINE.
2.	ANGLE METER STOP WITH LOCK WINGS AND FIP SWIVEL NUT x COMPRESSION FITTING CONNECTION [BALL-TYPE]. COPPER: FORD #BA43, JONES #J1963W; PVC: FORD #BA63, JONES #J4211W.
3.	1-1/4" PVC IDLER (JUMPER). SEE METER IDLER (JUMPER) DETAIL ABOVE.
4.	1" x 2-5/8" STRAIGHT METER COUPLING WITH 1" FEMALE IRON PIPE THREADS (FIPT).
5.	1" x 12" BRASS NIPPLE.
6.	1" BRASS TEE.
7.	1" x 3" BRASS NIPPLE.
8.	CUSTOMER'S VALVE: (F.I.P. x F.I.P.) BALL VALVE CURB STOP WITH LOCK WING. FORD #B11W; JONES #J1900W.
9.	1" BRASS PLUG (2).
10.	METER BOX: BES C16W METER BOX WITH C16G LID OR CHRISTY B16 METER BOX WITH B16G LID.
11.	METER BOX: BES C9W METER BOX WITH C9D LID OR CHRISTY B9 METER BOX WITH B9D LID.
12.	1-1/4" SLIP x MIP PVC ADAPTER.
13.	1-1/4" SCHEDULE 40 PVC PIPE.

**GENERAL NOTES:**

- FOR RETROFIT INSTALLATIONS OR AS APPROVED BY DISTRICT ENGINEER.
- SEE STANDARD DRAWING W-8 FOR METER AND SERVICE LINE LOCATION AND CLEARANCE REQUIREMENTS.
- ALL ITEMS LISTED TO BE INSTALLED BY WATER MAIN CONTRACTOR.
- ANY SEALS OR LOCKS PLACED ON A CLOSED ANGLE METER STOP OR CURB STOP SHALL NOT BE REMOVED EXCEPT BY NCSO.
- METER BOXES SHALL BE INSTALLED ON COMPACTED MATERIAL.
- IDLER (JUMPER) SHALL BE INSTALLED WITH TWO METER WASHERS.
- METER BOX SHALL BE LOCATED SUCH THAT CENTER OF READING LID OPENING IS DIRECTLY ABOVE CENTER OF METER IDLER.

		<b>NIPOMO COMMUNITY SERVICES DISTRICT</b>	
		<b>1" SERVICE LINE AND 1" METER IN DUAL METER BOX FOR RESIDENCES WITH FIRE SPRINKLERS</b>	
DATE	REVISION	DATE DRAWN MARCH 2011	SHEET NO. <b>W-8B</b>

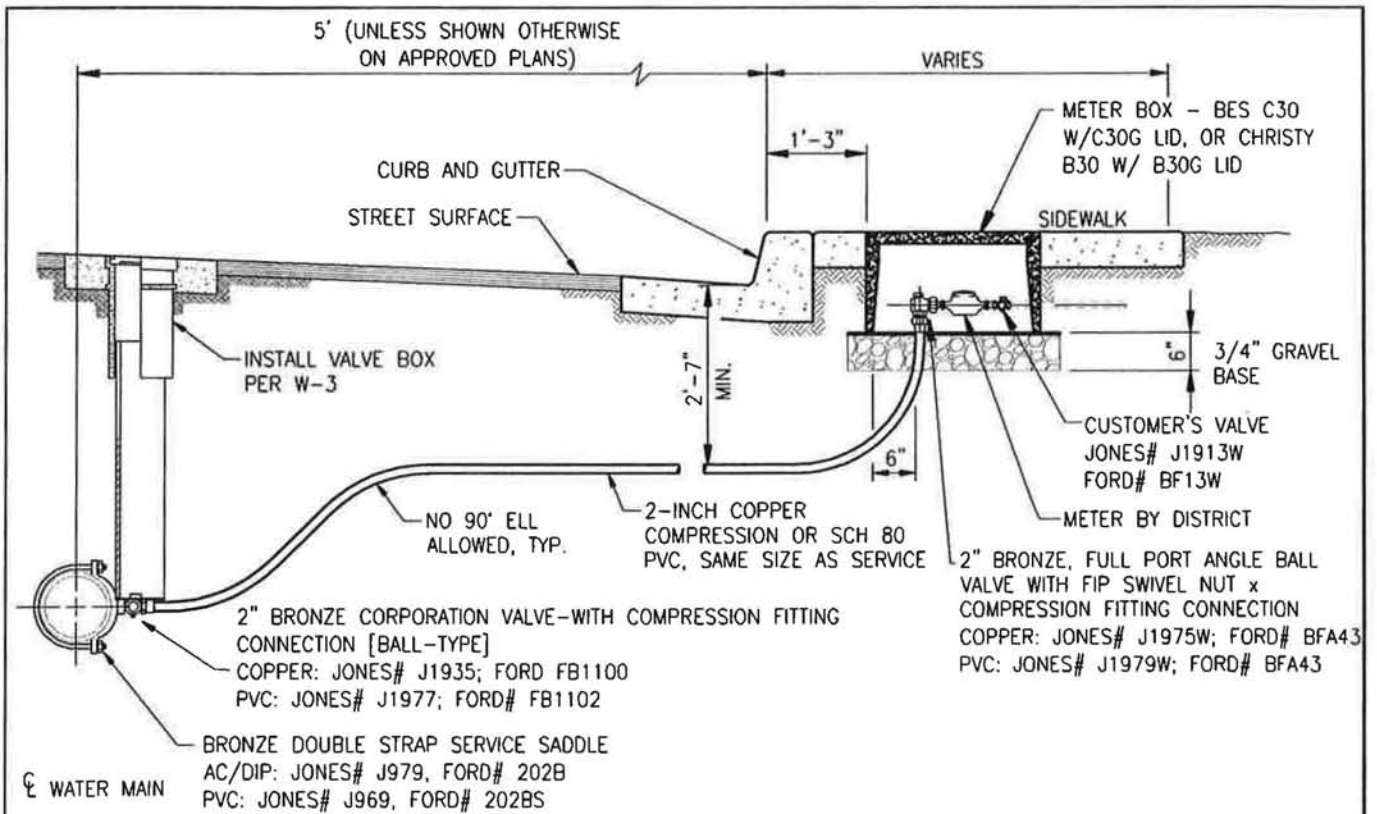

**GENERAL NOTES:**

1. IF METER BOX IS LOCATED ON A SLOPE NEXT TO A CURB, OR SIDEWALK, A PROTECTIVE RETAINING WALL SHALL BE CONSTRUCTED.
2. CORPORATION VALVE TAP SHALL BE MADE AS SPECIFIED BY THE PIPE MANUFACTURER'S INSTALLATION GUIDE. ALL DRY TAPS SHALL BE MADE WITH MACHINE WITH GUIDE OR PILOT FOR TAP.
3. SIZE OF THE SERVICE MUST BE APPROVED BY THE DISTRICT.
4. THE WATER SERVICE SHALL EXTEND PERPENDICULAR TO THE CENTERLINE OF THE STREET FROM THE WATER MAIN TO THE METER STOP.
5. CORPORATION VALVE TAP SHALL HAVE A SERVICE SADDLE AND SHALL BE MADE AS SPECIFIED BY THE PIPE MANUFACTURER'S INSTALLATION GUIDE. ALL DRY TAPS SHALL BE MADE BY MACHINE WITH GUIDE OR PILOT FOR TAP. (DIRECT TAPS WILL NOT BE ALLOWED)
6. PROVIDE 12 GAUGE INSULATED TRACER WIRE ALONG EACH SERVICE OF SUFFICIENT LENGTH TO EXTEND INTO METER BOX AND A MINIMUM OF 24-INCHES ABOVE FINISH GRADE. COIL NEATLY INSIDE BOX.

		<b>NIPOMO COMMUNITY SERVICES DISTRICT</b>	
		<b>1-1/2" &amp; 2" STANDARD WATER SERVICES</b>	
03/11	REVISE MODEL NUMBERS	DATE DRAWN	SHEET NO.
DATE	REVISION	MARCH 2008	<b>W-9</b>

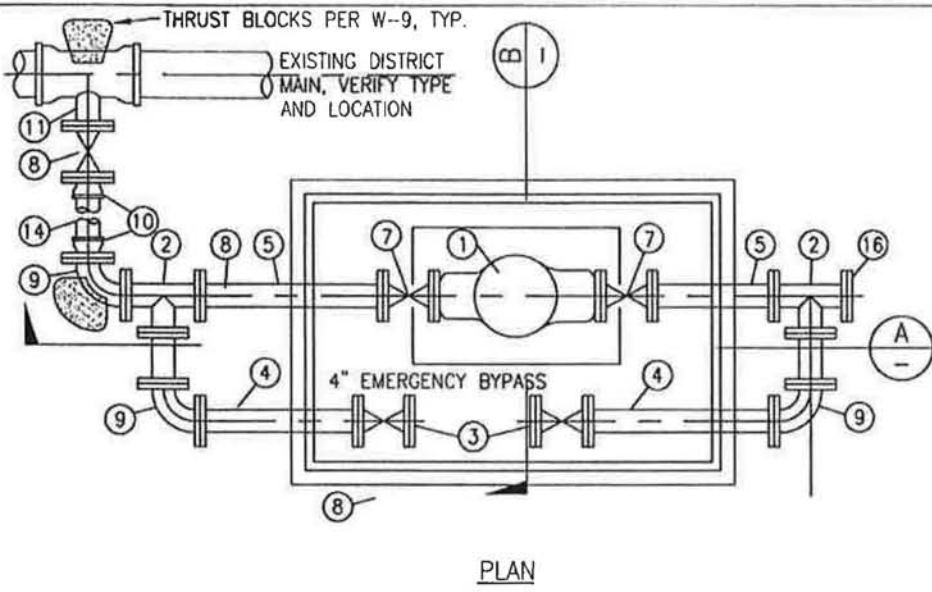

- MATERIAL LIST**
- ① METER AS DETERMINED BY DISTRICT
  - ② DUCTILE IRON PIPE TEE, FLG.x FLG.x FLG.
  - ③ BLIND FLANGE
  - ④ DUCTILE IRON PIPE, FLG.x FLG.
  - ⑤ DUCTILE IRON PIPE, FLG.x FLG.
  - ⑥ PRECAST CONCRETE VAULT, GALVANIZED COVER WITH 7"x 14" READING LID
  - ⑦ FLANGED GATE VALVE W/ HAND WHEEL
  - ⑧ GATE VALVE, FLANGED, WITH VALVE BOX
  - ⑨ DUCTILE IRON PIPE 90° BEND, FLG.x FLG.
  - ⑩ RESTRAINED FLANGE COUPLING ADAPTER
  - ⑪ DUCTILE IRON PIPE TEE WITH FLANGED OUTLET
  - ⑫ CLASS "A" CONCRETE SUPPORTS AS REQUIRED TO SUPPORT THE GATE VALVES AND METER
  - ⑬ CLASS II AGGREGATE BASE
  - ⑭ POLYVINYL CHLORIDE PIPE, (PVC), AWWA C900 OR DUCTILE IRON PIPE
  - ⑮ ADJUSTABLE PIPE SUPPORT, REQUIRED FOR 6" AND 8" ONLY
  - ⑯ BLIND FLANGE

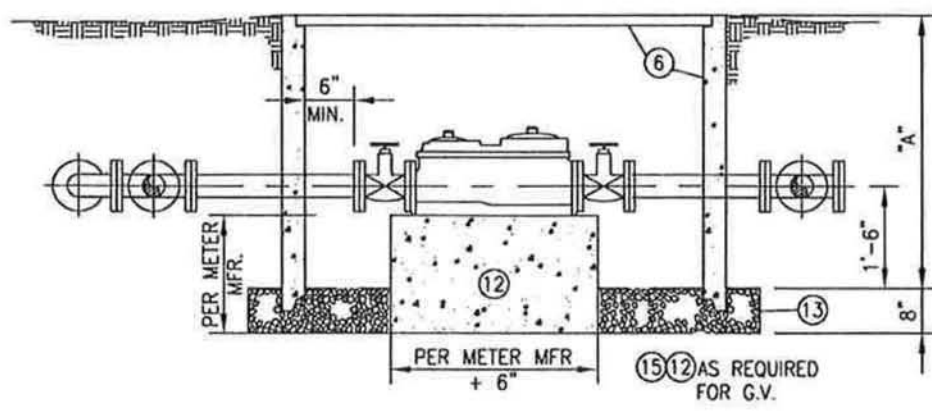

NOTE: 3" METER SHALL HAVE 4" DIAMETER PIPING AND VALVES REDUCED TO 3" AT THE METER.

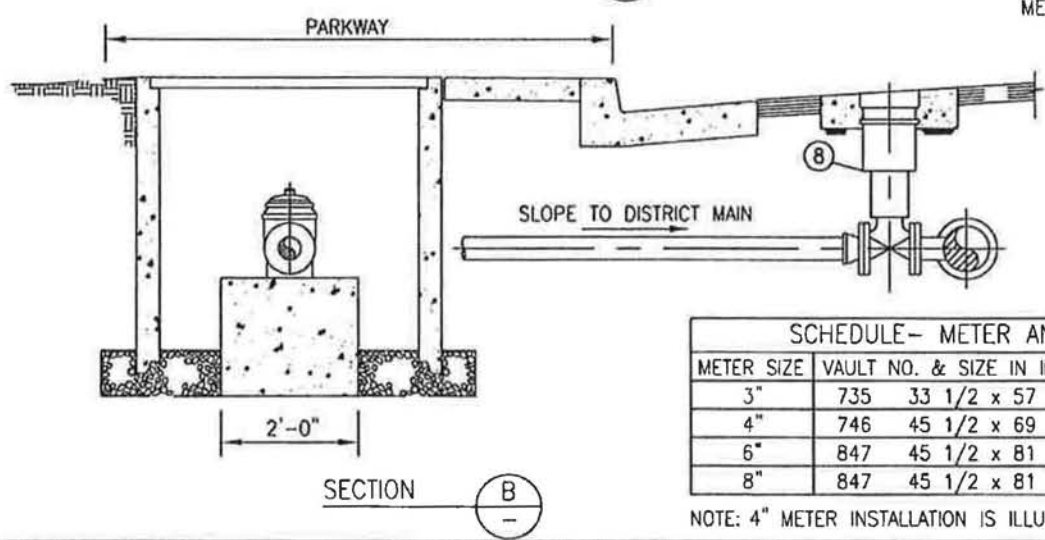

SCHEDULE- METER AND VAULT SIZES			
METER SIZE	VAULT NO. & SIZE IN INCHES	DIMENSION "A"	
3"	735 33 1/2 x 57 1/2	3'-3"±	
4"	746 45 1/2 x 69 1/2	4'-0"±	
6"	847 45 1/2 x 81 1/2	4'-0"±	
8"	847 45 1/2 x 81 1/2	4'-0"±	

NOTE: 4" METER INSTALLATION IS ILLUSTRATED ON THIS SHEET.

<b>NIPOMO COMMUNITY SERVICES DISTRICT</b>		DATE DRAWN MARCH 2008	SHEET NO. W-10
<b>STANDARD LARGE DIAMETER WATER METER</b>			
DATE	REVISION		

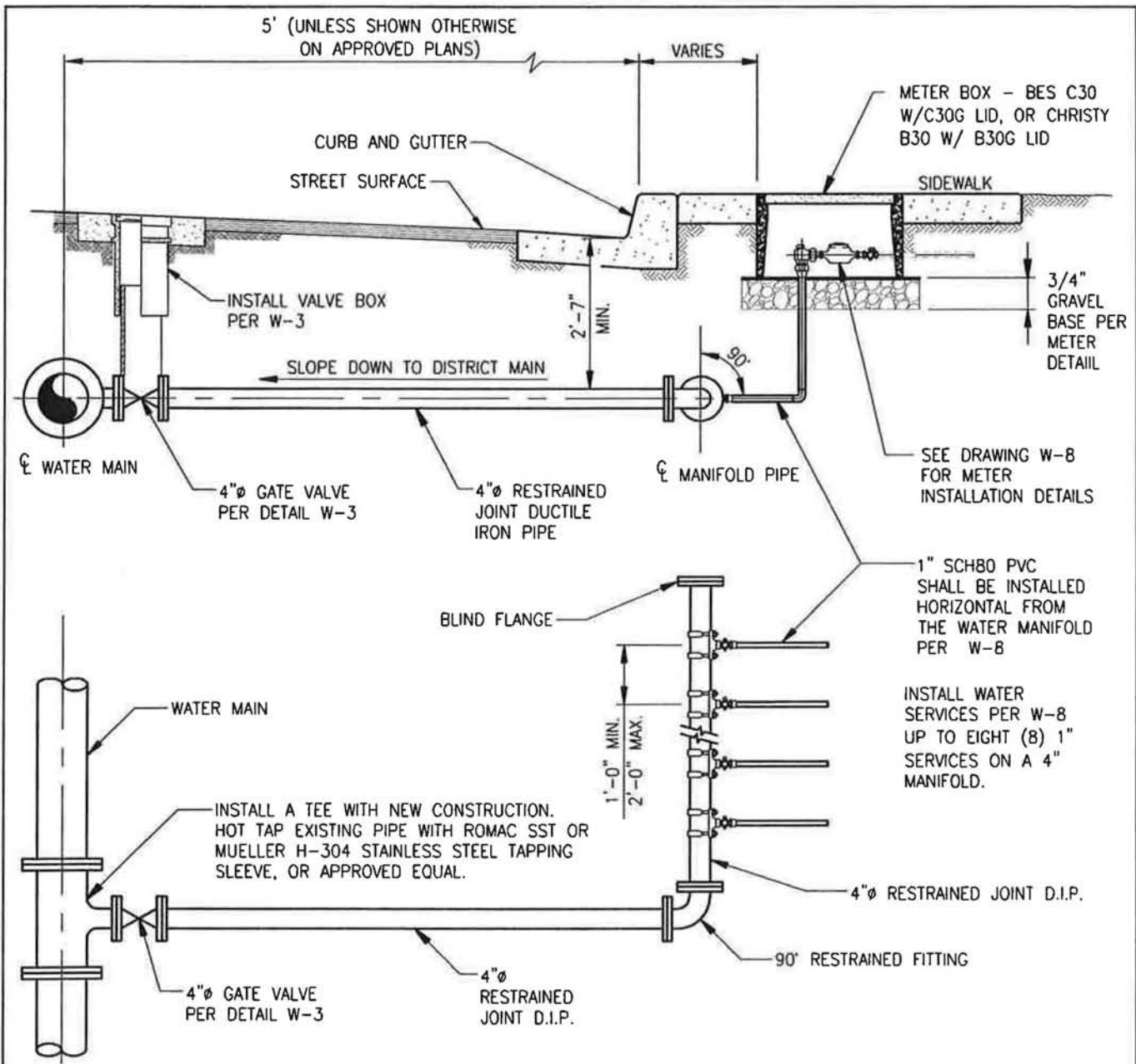

**GENERAL NOTES:**

1. IF METER BOX IS LOCATED ON A SLOPE NEXT TO A CURB, OR SIDEWALK, A PROTECTIVE RETAINING WALL SHALL BE CONSTRUCTED.
2. SIZE OF THE SERVICE MUST BE APPROVED BY THE DISTRICT.
3. THE WATER MAINFOLD SHALL EXTEND PERPENDICULAR TO THE CENTERLINE OF THE STREET FROM THE WATER MAIN TO THE ELBOW AND SHALL HAVE TAPE MARKED "CAUTION WATER LINE BELOW". TAPE TO BE 15-INCHES ABOVE THE PIPE.
4. PROVIDE 12 GAUGE INSULATED TRACER WIRE ALONG EACH SERVICE OF SUFFICIENT LENGTH TO EXTEND INTO METER BOX AND A MINIMUM OF 24-INCHES ABOVE FINISH GRADE. COIL NEATLY INSIDE BOX.

		<b>NIPOMO COMMUNITY SERVICES DISTRICT</b>	
		<b>4" MANIFOLD WATER SERVICE</b>	
03/11	REVISE TEXT	DATE DRAWN	SHEET NO.
DATE	REVISION	MARCH 2008	<b>W-11</b>

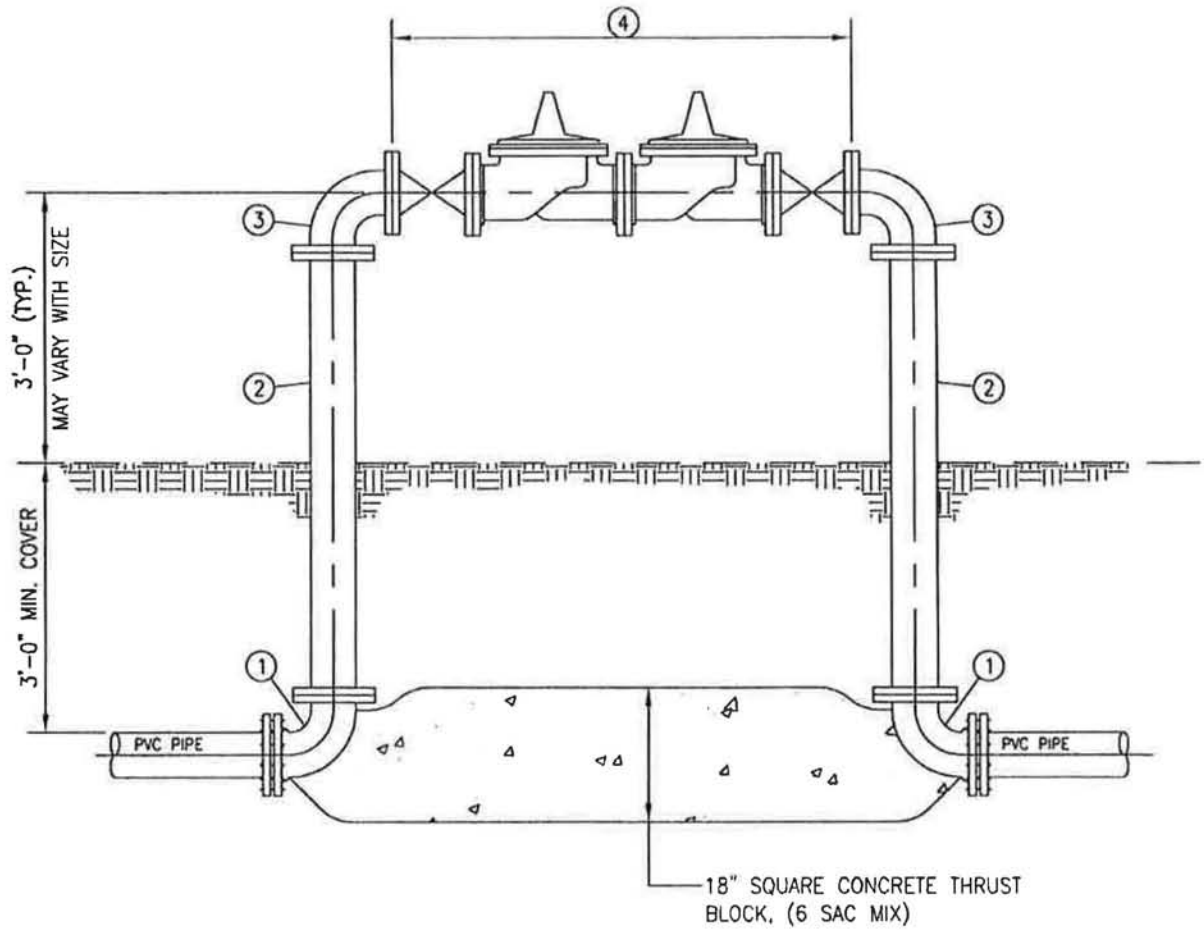

**MATERIAL LIST**

- ① 90° D.I. ELBOW, FLG x MJ
- ② D.I. SPOOL, FLG x FLG, (CLASS 53 MIN)
- ③ 90° D.I. ELBOW, FLG x FLG
- ④ DOUBLE CHECK DETECTOR BACKFLOW PREVENTER AND FLANGED GATE VALVE ASSEMBLY, AMES 3000SS, FEBCO 806YD, WATTS 709 OR EQUAL

**NOTE:**

- 1. DUCTILE IRON PIPE (D.I.P.) AND FITTINGS SHALL BE CEMENT MORTAR LINED PER AWWA C104.
- 2. ALTERNATIVE MATERIAL IS FUSION BONDED EPOXY LINED AND COATED STEEL PIPE AND FITTINGS.

		<b>NIPOMO COMMUNITY SERVICES DISTRICT</b>	
		<b>DOUBLE CHECK DETECTOR BACKFLOW PREVENTOR- 4" THRU 12"</b>	
		DATE DRAWN MARCH 2008	SHEET NO. W-12
DATE	REVISION		

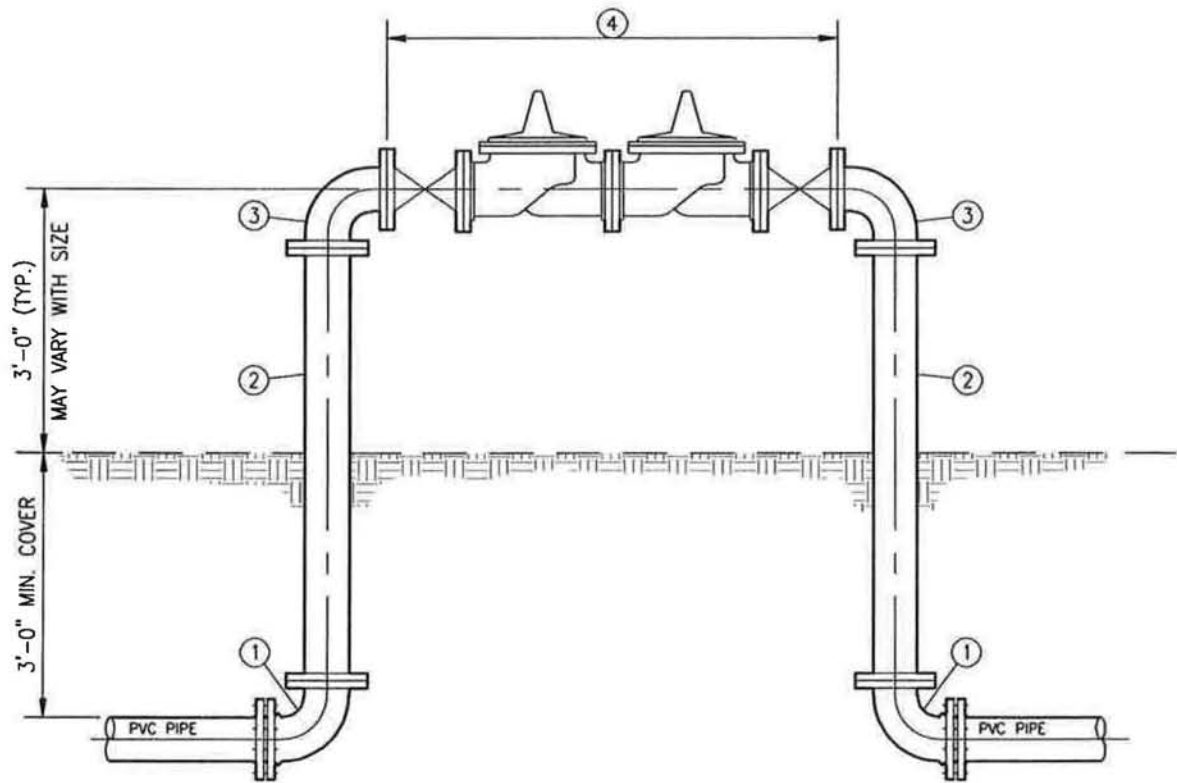

**MATERIAL LIST**

- ① 90° D.I. ELBOW, FLG x MJ
- ② D.I. SPOOL, FLG x FLG, (CLASS 53 MIN)
- ③ 90° D.I. ELBOW, FLG x FLG
- ④ DOUBLE CHECK DETECTOR BACKFLOW PREVENTER AND FLANGED GATE VALVE ASSEMBLY, AMES 3000SS, FEBCO 806YD, WATTS 709 OR EQUAL

**NOTE:**

- 1. DUCTILE IRON PIPE (D.I.P.) AND FITTINGS SHALL BE CEMENT MORTAR LINED PER AWWA C104.
- 2. ALTERNATIVE MATERIAL IS FUSION BONDED EPOXY LINED AND COATED STEEL, COPPER, OR BRASS PIPE AND FITTINGS.
- 3. WHEN SERVICE IS METERED, DOUBLE CHECK PREVENTER, WITHOUT DETECTOR, IS ALLOWED.

		<b>NIPOMO COMMUNITY SERVICES DISTRICT</b>	
		<b>DOUBLE CHECK DETECTOR BACKFLOW PREVENTER- LESS THAN 4"</b>	
DATE	REVISION	DATE DRAWN MARCH 2011	SHEET NO. <b>W-12A</b>

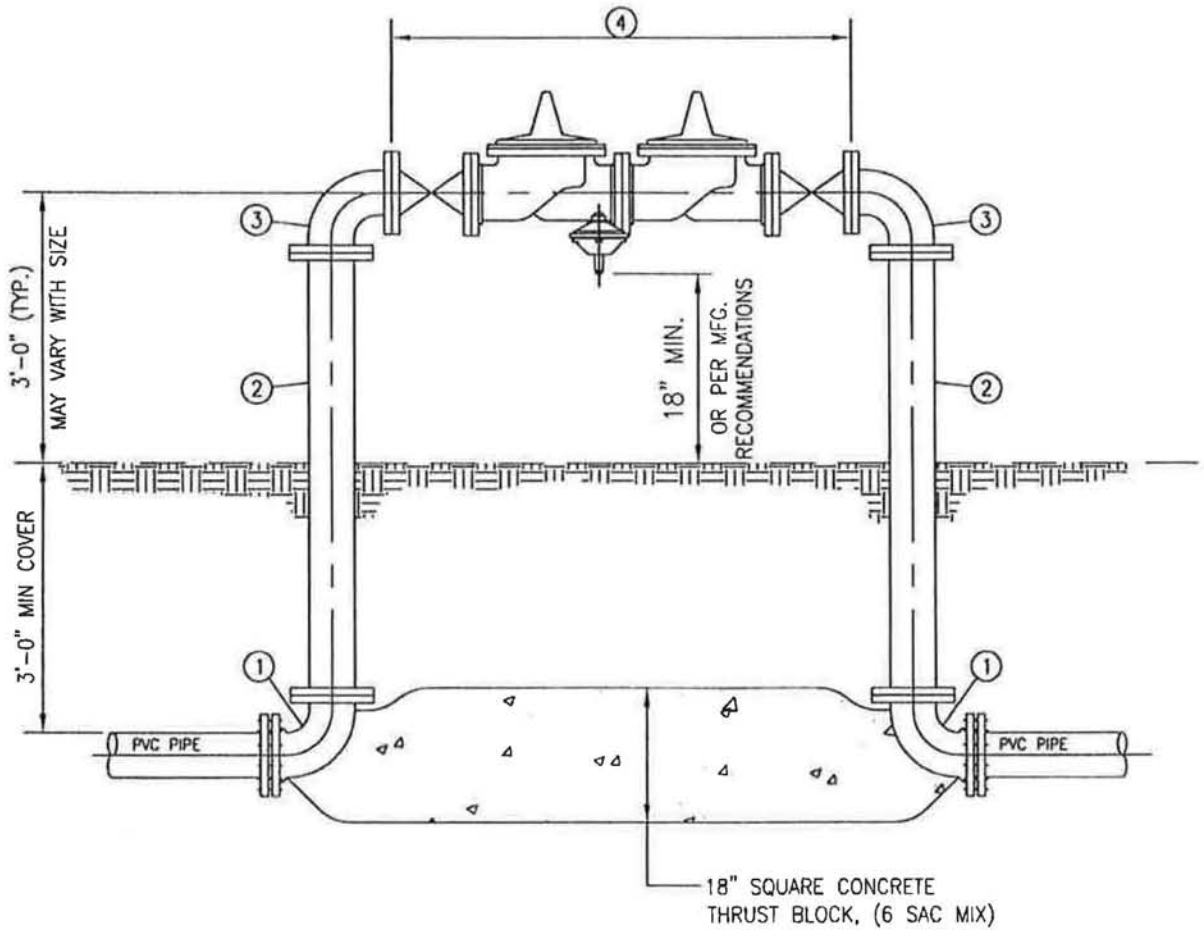

**MATERIAL LIST**

- ① 90° D.I. ELBOW, FLG x MJ
- ② D.I. SPOOL, FLG x FLG, (CLASS 53 MIN)
- ③ 90° D.I. ELBOW, FLG x FLG
- ④ REDUCED PRESSURE PRINCIPLE BACKFLOW PREVENTER AND FLANGED GATE VALVE ASSEMBLY AS MFG BY;  
AMES, MODEL 5000SS,  
CLA-VAL MODEL RP-4  
FEBCO MODEL 826YD,  
WATTS 909, OR EQUIVALENT

**NOTE:**

- 1. DUCTILE IRON PIPE (D.I.P.) AND FITTINGS SHALL BE CEMENT MORTAR LINED PER AWWA C104.
- 2. ALTERNATIVE MATERIAL IS FUSION BONDED EPOXY LINED AND COATED STEEL PIPE AND FITTINGS.

		<b>NIPOMO COMMUNITY SERVICES DISTRICT</b>	
		<b>REDUCED PRESSURE PRINCIPLE BACKFLOW PREVENTER, 4" THRU 12"</b>	
DATE	REVISION	DATE DRAWN MARCH 2008	SHEET NO. W-13



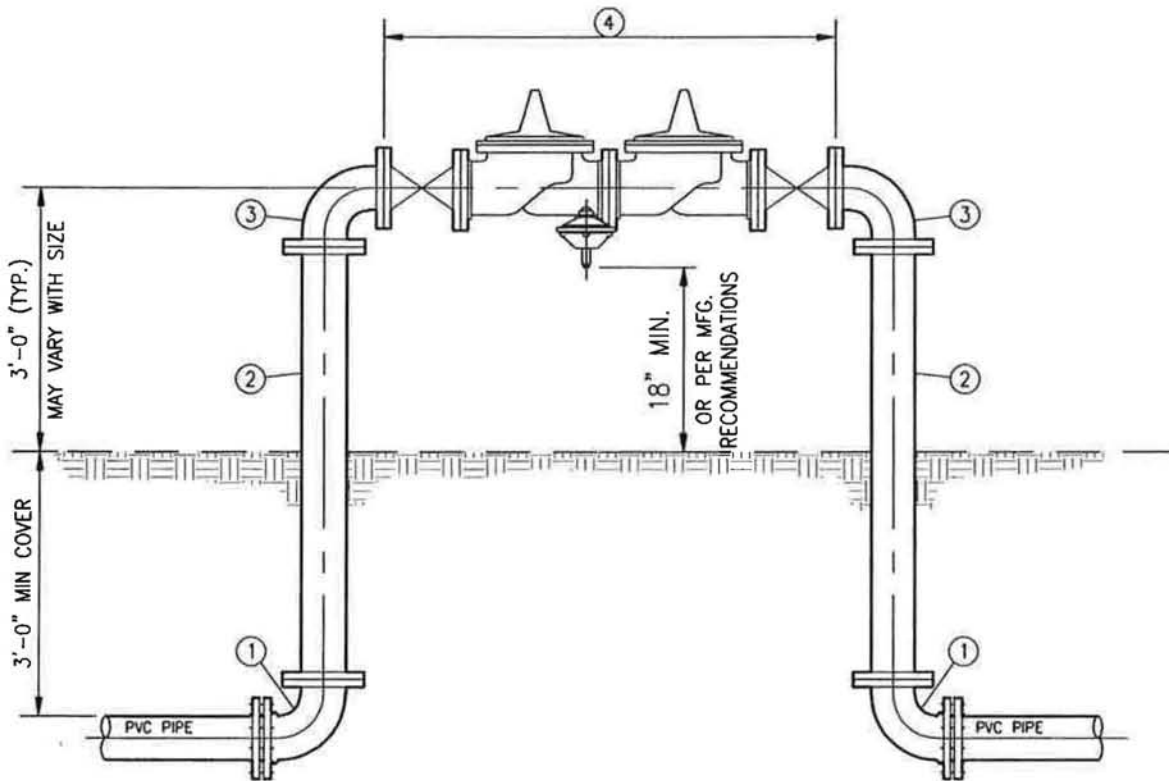

**MATERIAL LIST**

- ① 90° D.I. ELBOW, FLG x MJ
- ② D.I. SPOOL, FLG x FLG, (CLASS 53 MIN)
- ③ 90° D.I. ELBOW, FLG x FLG
- ④ REDUCED PRESSURE PRINCIPLE BACKFLOW PREVENTER AND FLANGED GATE VALVE ASSEMBLY AS MFG BY:  
AMES, MODEL 5000SS,  
CLA-VAL MODEL RP-4  
FEBCO MODEL 826YD,  
WATTS 909, OR EQUIVALENT

**NOTE:**

- 1. DUCTILE IRON PIPE (D.I.P.) AND FITTINGS SHALL BE CEMENT MORTAR LINED PER AWWA C104.
- 2. ALTERNATIVE MATERIAL IS FUSION BONDED EPOXY LINED AND COATED STEEL, COPPER, OR BRASS PIPE AND FITTINGS.

		<b>NIPOMO COMMUNITY SERVICES DISTRICT</b>	
		<b>REDUCED PRESSURE PRINCIPLE BACKFLOW PREVENTER, LESS THAN 4"</b>	
DATE	REVISION	DATE DRAWN MARCH 2011	SHEET NO. <b>W-13A</b>

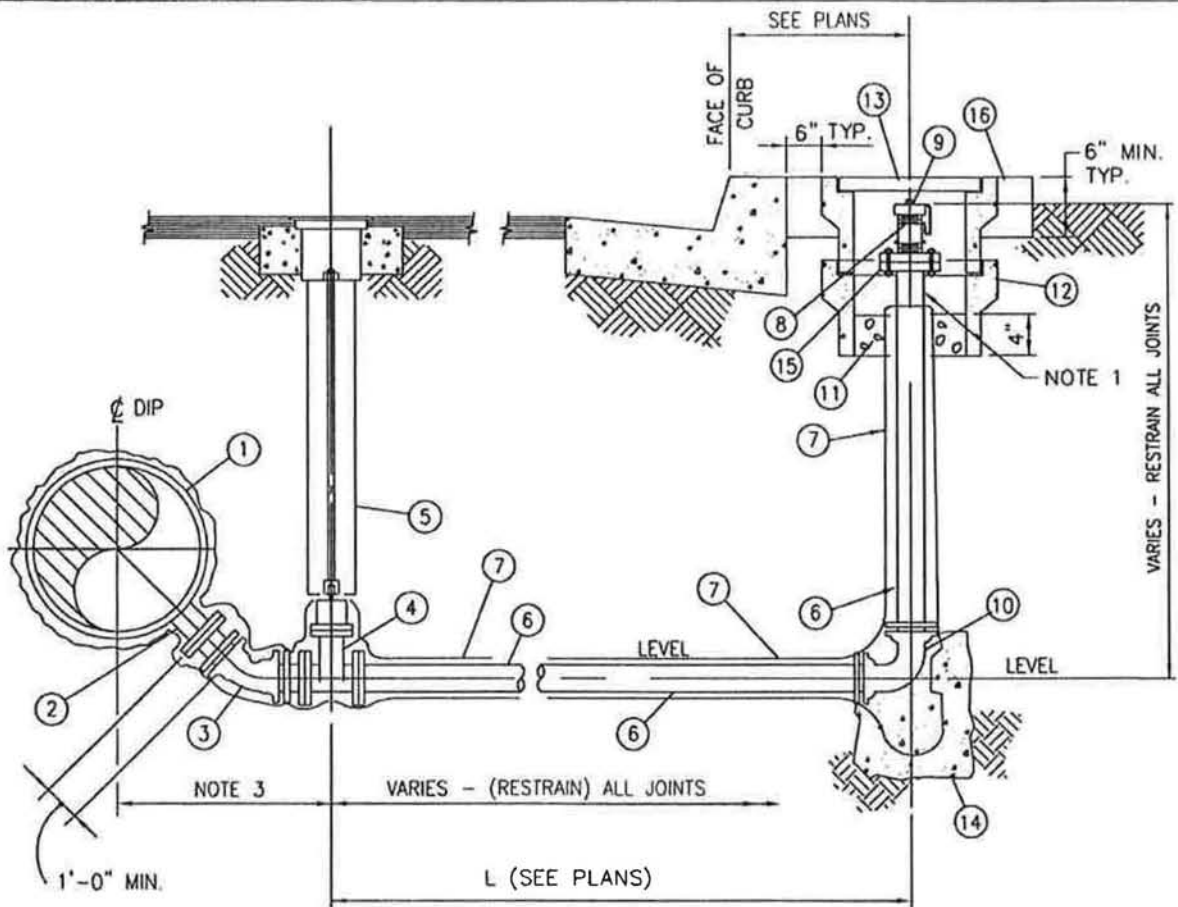

- | ITEM | DESCRIPTION   |
|------|---|
| ①    | WATERMAIN   |
| ②    | FLANGED OUTLET  |
| ③    | DIP MJ 45° ELBOW WITH RESTRAINED JOINTS                             |
| ④    | GATE VALVE, RESILIENT WEDGE   |
| ⑤    | VALVE BOX INSTALLATION FOR BURIED VALVES PER W-3                    |
| ⑥    | 4" CLASS 350 DIP  |
| ⑦    | POLYETHYLENE ENCASING   |
| ⑧    | 2 1/2" BRONZE NIPPLE, REGULAR WALL, IPT x FIRE HOSE THREAD.         |
| ⑨    | PVC PIPE CAP  |
| ⑩    | DIP MJ 90° ELBOW WITH RESTRAINED JOINTS                             |
| ⑪    | 3/4" GRAVEL   |
| ⑫    | H-20 TRAFFIC RATED PRECAST VALVE BOX, CHRISTY G8 OR APPROVED EQUAL. |
| ⑬    | HS-20 TRAFFIC RATED, BOLTED, GALVANIZED STEEL HATCH                 |
| ⑭    | CONCRETE ANCHOR BLOCK, 6 SQ.FT. MIN.                                |
| ⑮    | 4" CLASS 150 FLANGES, TAPPED COMPANION FLANGE TO MATCH ITEM B.      |
| ⑯    | 6" SQ. CONCRETE COLLAR  |

**NOTES:**

1. WATERMANS WITH A DIAMETER GREATER THAN 12" SHALL USE A 6" OUTLET FROM THE MAIN WITH A 6" LATERAL AND VALVE AND A 4" BRONZE NIPPLE.
2. MINIMIZE DISTANCE BETWEEN OUTLET AND VALVE TO CLEAR PIPE BY 6".
3. LENGTH L IS APPROXIMATE HORIZONTAL LENGTH OF BLOWOFF PIPING BETWEEN MAIN PIPE AND BLOWOFF BOX.

		<b>NIPOMO COMMUNITY SERVICES DISTRICT</b>	
		<b>BLOWOFF ASSEMBLY</b>	
DATE	REVISION	DATE DRAWN MARCH 2008	SHEET NO. W-14

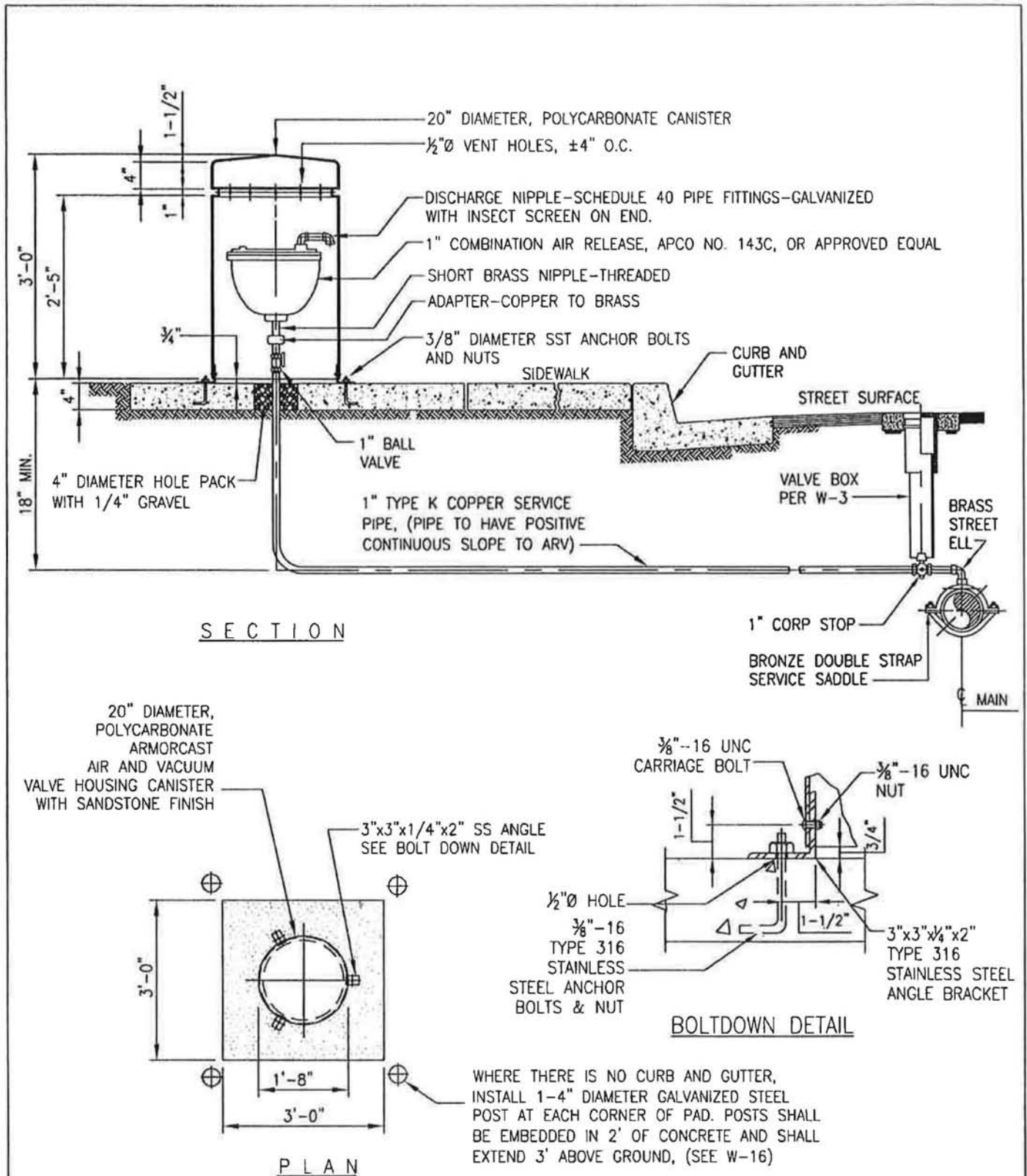

		<b>NIPOMO COMMUNITY SERVICES DISTRICT</b>	
		<b>COMBINATION AIR RELEASE VALVE ASSEMBLY</b>	
DATE	REVISION	DATE DRAWN MARCH 2008	SHEET NO. W-15

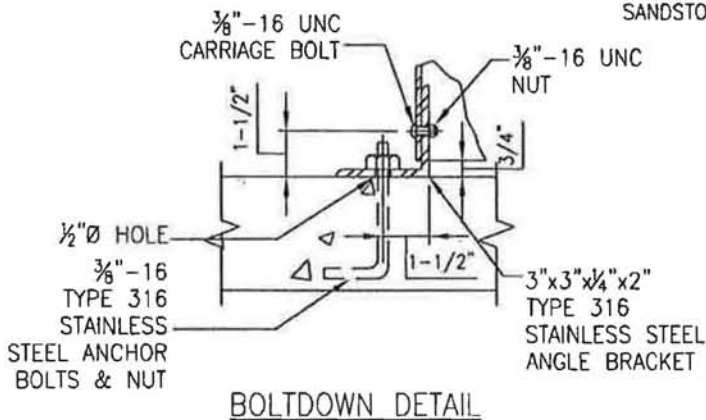
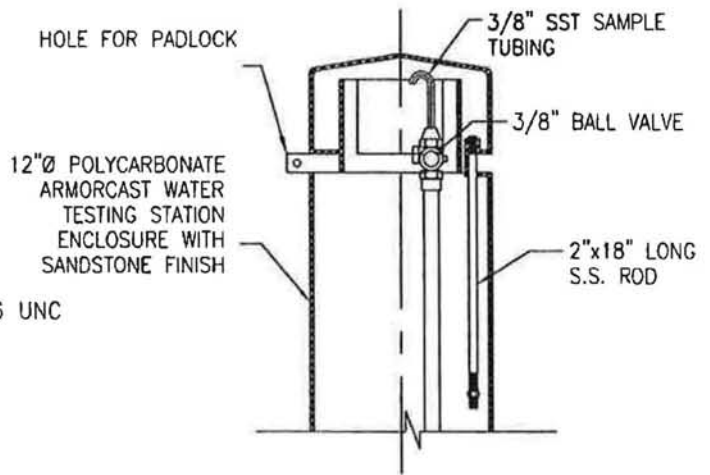
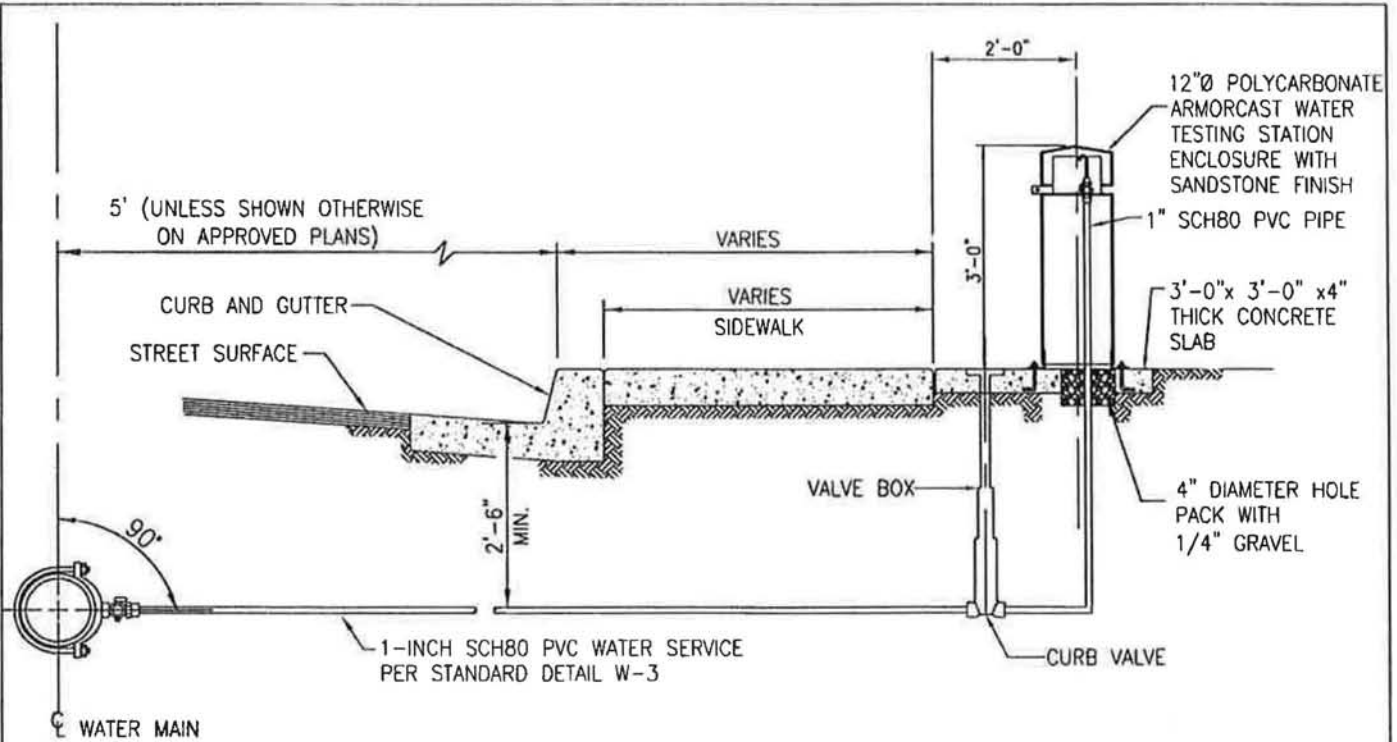

BOLTDOWN DETAIL

		<b>NIPOMO COMMUNITY SERVICES DISTRICT</b>	
		<b>SAMPLE STATION</b>	
DATE	REVISION	DATE DRAWN MARCH 2008	SHEET NO. <b>W-16</b>

**SEWER NOTES**

1. THE SEWER FACILITIES TO BE DEDICATED TO THE NCSD (DISTRICT) SHALL BE CONSTRUCTED IN ACCORDANCE WITH THE CURRENT NCSD STANDARD SPECIFICATIONS FOR WATER AND SEWER IMPROVEMENTS. THE OMISSION OF ANY CURRENT STANDARD DETAIL DOES NOT RELIEVE THE CONTRACTOR FROM THIS REQUIREMENT.
2. THE DISTRICT SHALL BE NOTIFIED AT LEAST SEVEN (7) WORKING DAYS PRIOR TO START OF CONSTRUCTION. TELEPHONE (805) 929-1133. CONSTRUCTION WILL NOT TAKE PLACE ON WEEKENDS UNLESS SPECIFICALLY APPROVED BY THE DISTRICT. A PRECONSTRUCTION MEETING IS REQUIRED IN ACCORDANCE WITH DISTRICT STANDARDS GENERAL CONDITIONS SECTION 3.6.
3. THE CONSTRUCTION PLANS MUST BE APPROVED BY THE DISTRICT PRIOR TO THE START OF ANY SEWER CONSTRUCTION. TWO (2) SETS OF APPROVED PLANS SHALL BE FURNISHED TO THE DISTRICT. PRIOR TO DISTRICT APPROVAL, THE PLANS MUST BE SIGNED BY A CALIFORNIA REGISTERED CIVIL ENGINEER. ALL UTILITIES SHALL APPROVE PLANS PRIOR TO NCSD.
4. PRIOR TO ACCEPTANCE OF THE SEWER FACILITIES, ALL NECESSARY EASEMENT DOCUMENTS SHALL BE PROPERLY EXECUTED AND FURNISHED TO DISTRICT FOR BOARD APPROVAL PRIOR TO RECORDING.
5. PRIOR TO THE ACCEPTANCE OF THE SEWER FACILITIES, ALL PIPING SHALL BE MANDREL INSPECTED, AND TESTED FOR LEAKAGE AND INFILTRATION. ALL PIPING SHALL BE TELEVISION INSPECTED. ALL PIPING SHALL BE CLEANED PER DISTRICT STANDARDS, IN CONFORMANCE WITH THE TECHNICAL SPECIFICATIONS FOR CLEAN-UP.
6. THE MANHOLE FRAME AND COVER AND CONCRETE SUPPORT FOR MANHOLES SHALL BE RAISED AND CONSTRUCTED TO FINISHED PAVED GRADE AFTER PAVING IS COMPLETED. THE RING SECTION SHALL NOT BE MORE THAN 18" FROM THE CONE. THE SEWER SYSTEM SHALL BE CLEANED PRIOR TO ACCEPTANCE.
7. WORK SHALL BE DONE IN ACCORDANCE WITH THE APPROPRIATE ENCROACHMENT PERMITS.
8. THE SEWER SYSTEM, INCLUDING LATERALS, SHALL BE HYDROSTATIC OR AIR TESTED, AFTER ALL UNDERGROUND UTILITIES ARE CONSTRUCTED, AND PRIOR TO PLACING STREET PAVEMENT.
9. EXISTING SEWER LOCATIONS AND FLOWLINE ELEVATIONS SHALL BE VERIFIED BY THE CONTRACTOR BEFORE START OF CONSTRUCTION. THE DISTRICT SHALL BE NOTIFIED IMMEDIATELY OF ANY DISCREPANCIES.
10. UPON COMPLETION OF CONSTRUCTION, ONE COMPLETE SET OF DRAWINGS, ORIGINAL PLOTS ON MYLAR, ALONG WITH ELECTRONIC (AUTOCAD DWG) FILES SHALL BE FURNISHED TO THE DISTRICT.
11. ALL SEWER MANHOLES SHALL BE COATED PER DISTRICT STANDARDS.

		<b>NIPOMO COMMUNITY SERVICES DISTRICT</b>	
		<b>STANDARD SEWER NOTES</b>	
03/11	REVISE TEXT		
DATE	REVISION	DATE DRAWN MARCH 2008	SHEET NO. <b>S-1</b>



LOCATE MH SHAFT OPENING  
OVER DOWNSTREAM SIDE OF MH

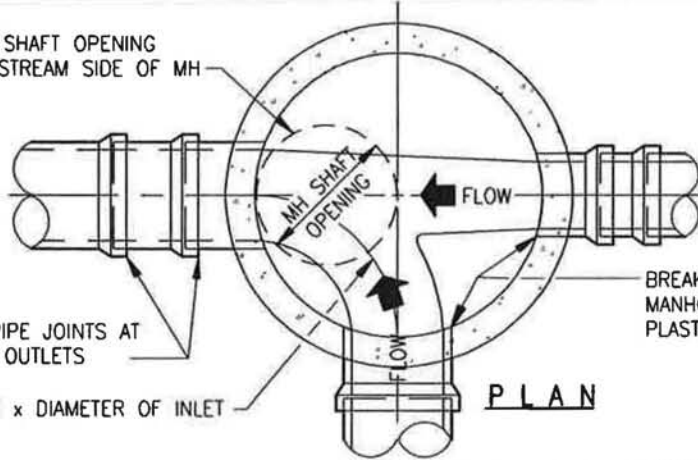

24" LONG PIPE JOINTS AT  
INLETS AND OUTLETS

RADIUS = 2 x DIAMETER OF INLET

BREAK PIPE FLUSH WITH INSIDE OF  
MANHOLE WALL. UNEVEN EDGES SHALL BE  
PLASTERED SMOOTH WITH CEMENT MORTAR.

**PLAN**

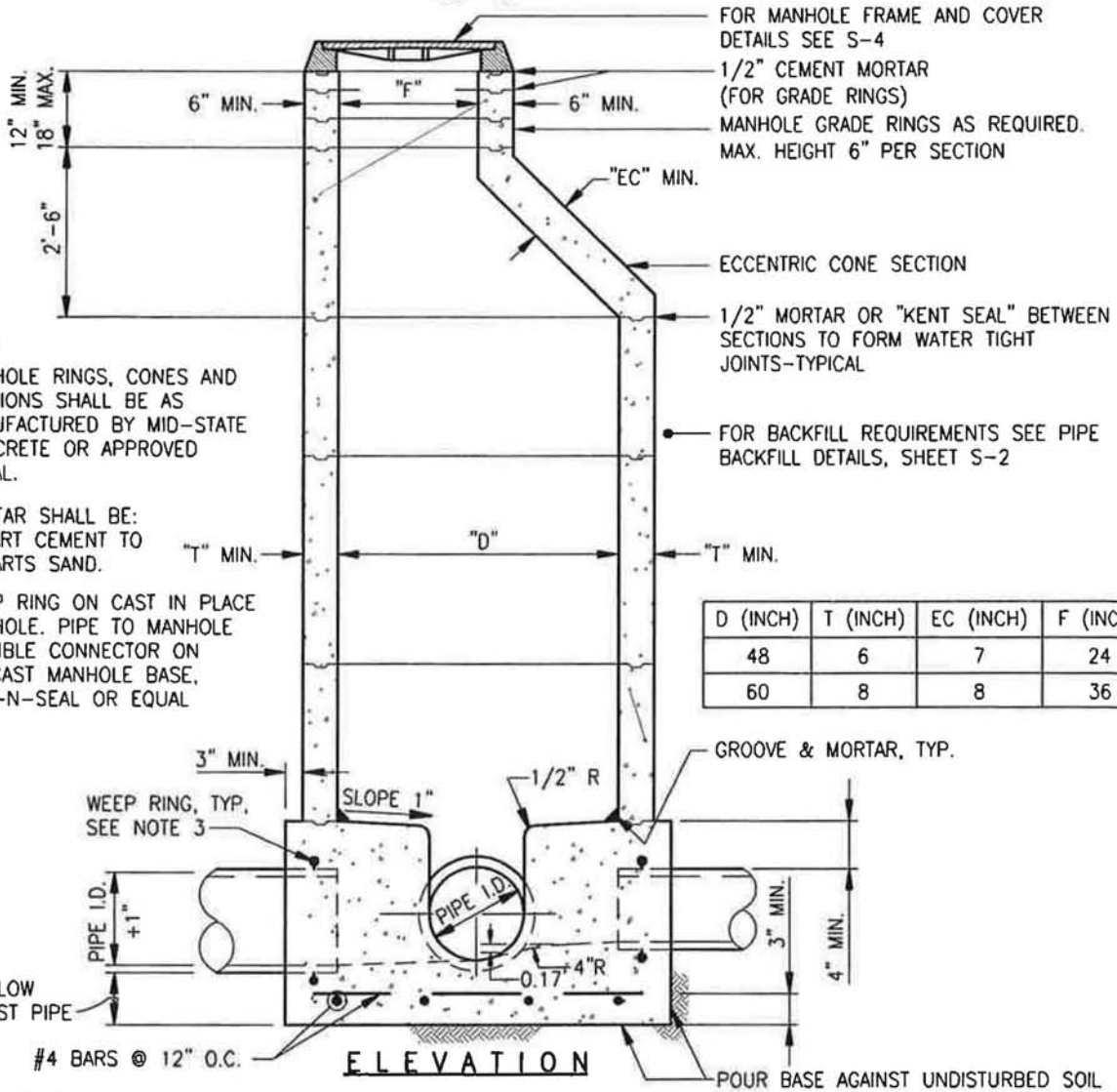

**NOTES:**

1. MANHOLE RINGS, CONES AND SECTIONS SHALL BE AS MANUFACTURED BY MID-STATE CONCRETE OR APPROVED EQUAL.
2. MORTAR SHALL BE: 1 PART CEMENT TO 4 PARTS SAND.
3. WEEP RING ON CAST IN PLACE MANHOLE. PIPE TO MANHOLE FLEXIBLE CONNECTOR ON PRECAST MANHOLE BASE, KOR-N-SEAL OR EQUAL

**ELEVATION**

**NIPOMO  
COMMUNITY SERVICES DISTRICT**

**48" AND 60" I.D. STANDARD MANHOLE**

03/11 REVISE TEXT AND REVERSE BELLS

DATE REVISION

DATE DRAWN  
MARCH 2008

SHEET NO.  
**S-3**



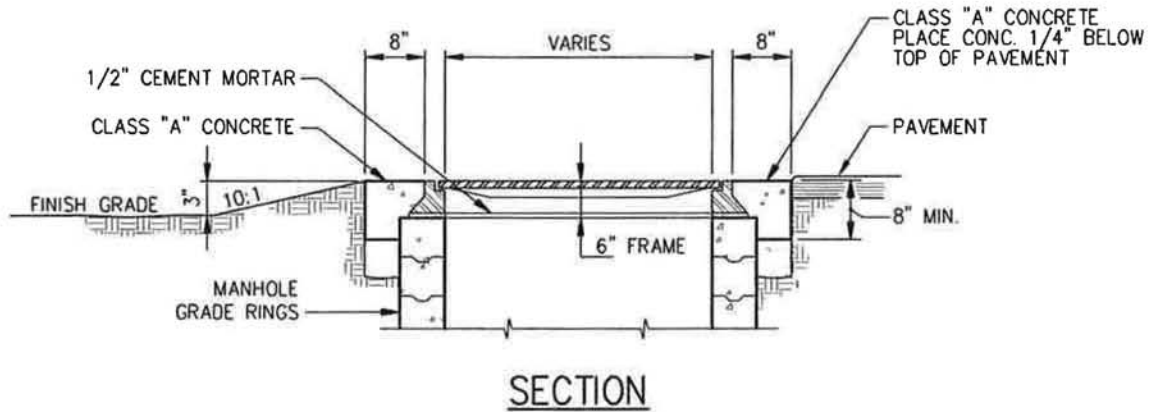
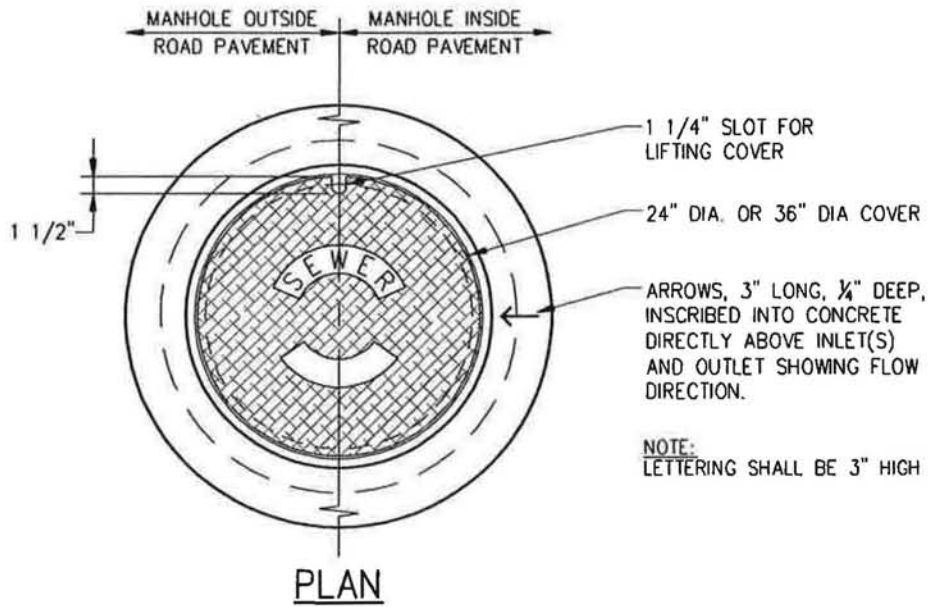

**NOTE:**  
1. MANHOLE FRAME AND COVER TO BE MODEL NO. 1495, 200 LB LID AS MANUFACTURED BY SOUTH BAY FOUNDRY OR EQUAL.

		<b>NIPOMO COMMUNITY SERVICES DISTRICT</b>	
		<b>MANHOLE FRAME AND COVER</b>	
03/11	CONCRETE COLLAR		
DATE	REVISION	DATE DRAWN MARCH 2008	SHEET NO. <b>S-4</b>

**NOTES:**

1. USE DROP TYPE CONNECTION WHERE DEFFERENCE IN ELEV. BETWEEN THE MAIN AND INTERSECTING PIPE > 2.5 ft. WITH DISTRICT APPROVAL
2. EXTEND DROP ENCASEMENT TO SPRING LINE OF INCOMING PIPE.
3. DROP TO BE SAME SIZE AS INCOMING PIPE.
4. SEE S-4 FOR MANHOLE FRAME AND COVER INSTALLATION.
5. IF CLEANOUT LID IS WITHIN TRAVELED WAY USE TRAFIC LID AND CONSTRUCT CLASS "A" CONCRETE COLLAR SEE SHT. W-3.

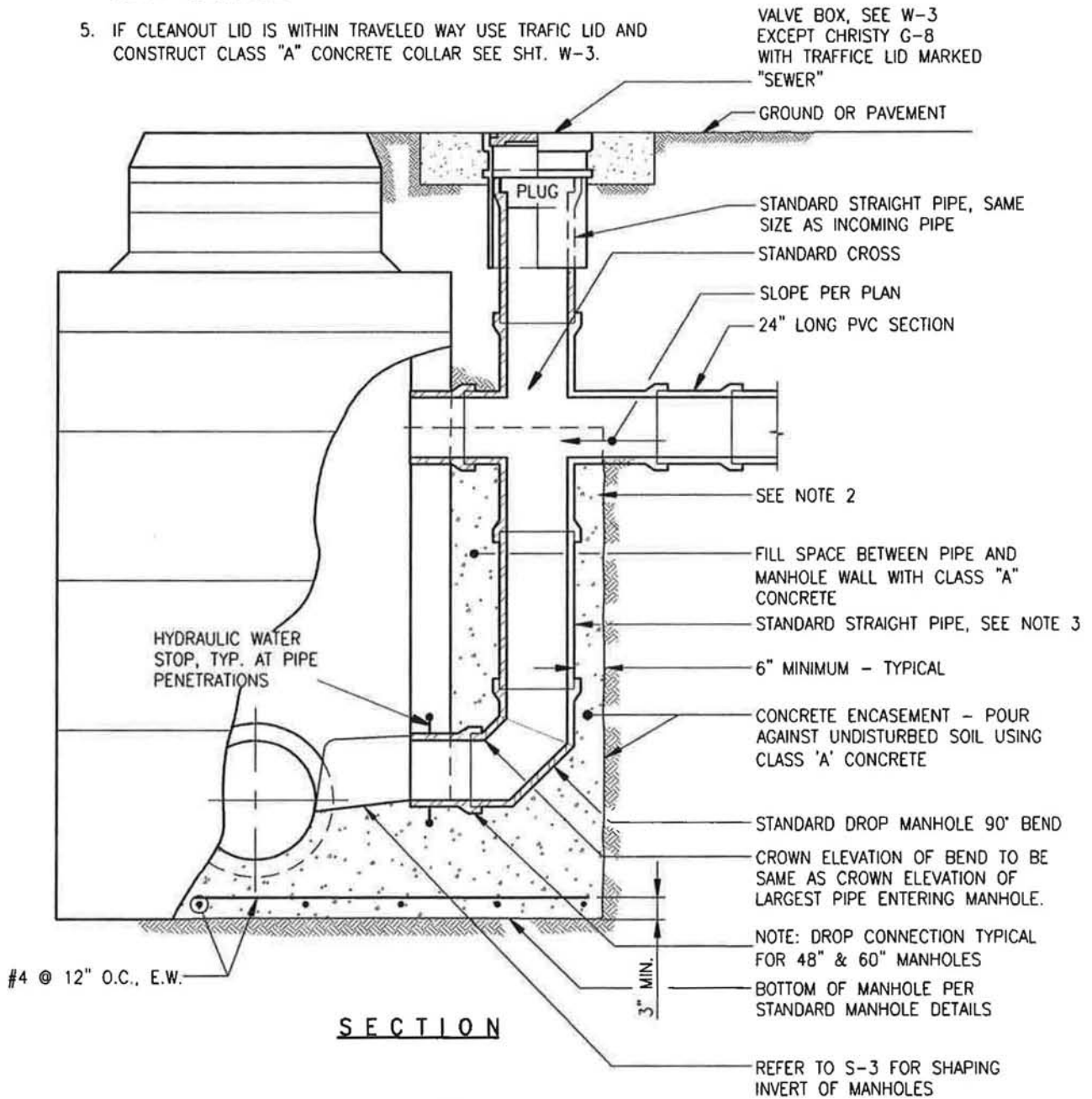

		<b>NIPOMO COMMUNITY SERVICES DISTRICT</b>	
		<b>MANHOLE - DROP INLET</b>	
03/11	REVISE TEXT	DATE DRAWN	SHEET NO.
DATE	REVISION	MARCH 2008	<b>S-5</b>

LOCATE SEWER WITH A 1-1/2" HIGH "S", CHISELED ON TOP OF CURB WHERE LATERAL CROSSES UNDER CURB. WHERE NO CURB EXISTS, OR WHERE LATERAL ENDS 8' OR MORE BACK OF CURB, (SET A 3-FOOT LONG METAL T-POST EXTENDING 2" ABOVE FINISHED GRADE).

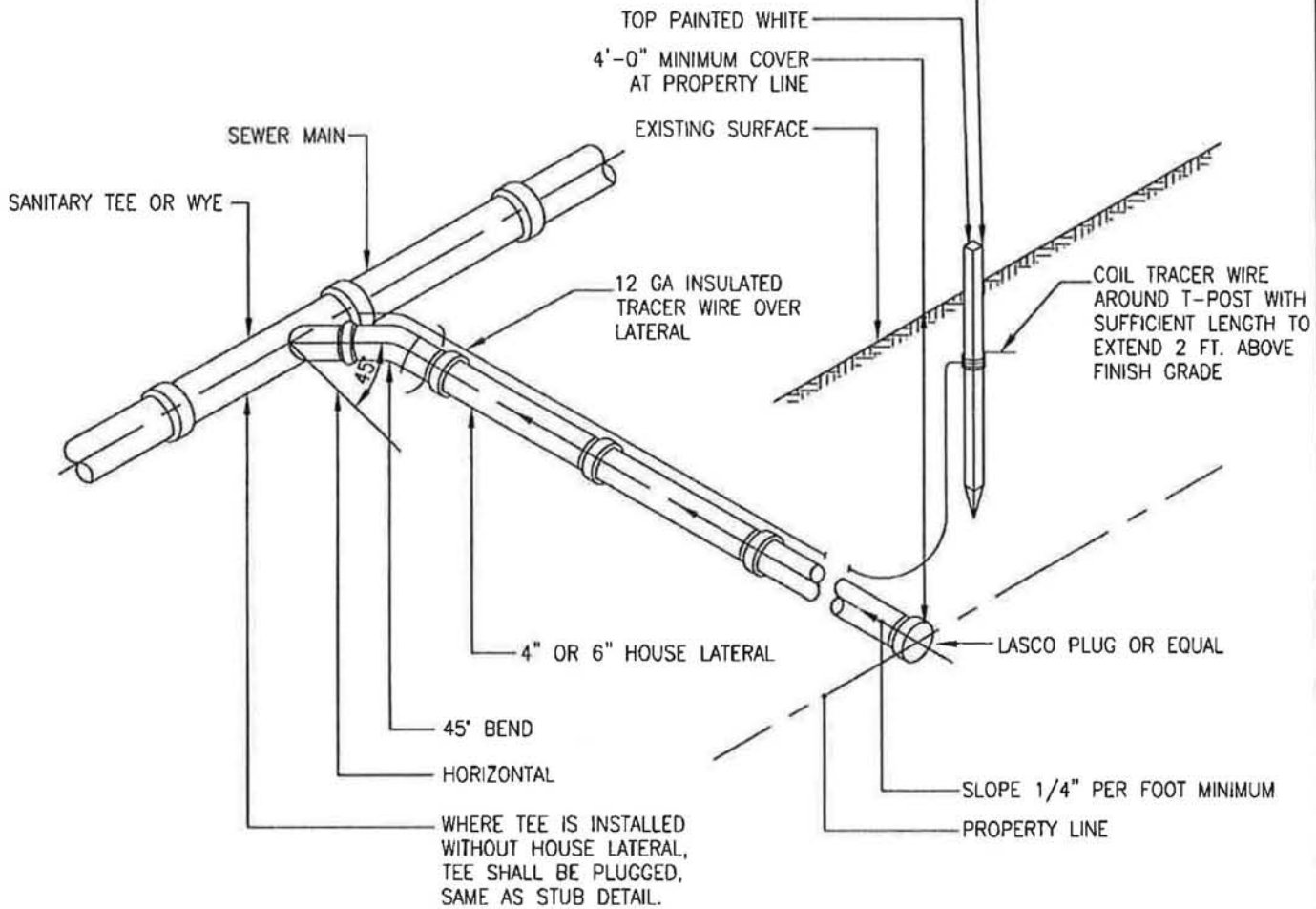

I S O M E T R I C

		NIPOMO COMMUNITY SERVICES DISTRICT	
		TYPICAL SEWER LATERAL	
DATE	REVISION	DATE DRAWN MARCH 2008	SHEET NO. S-6

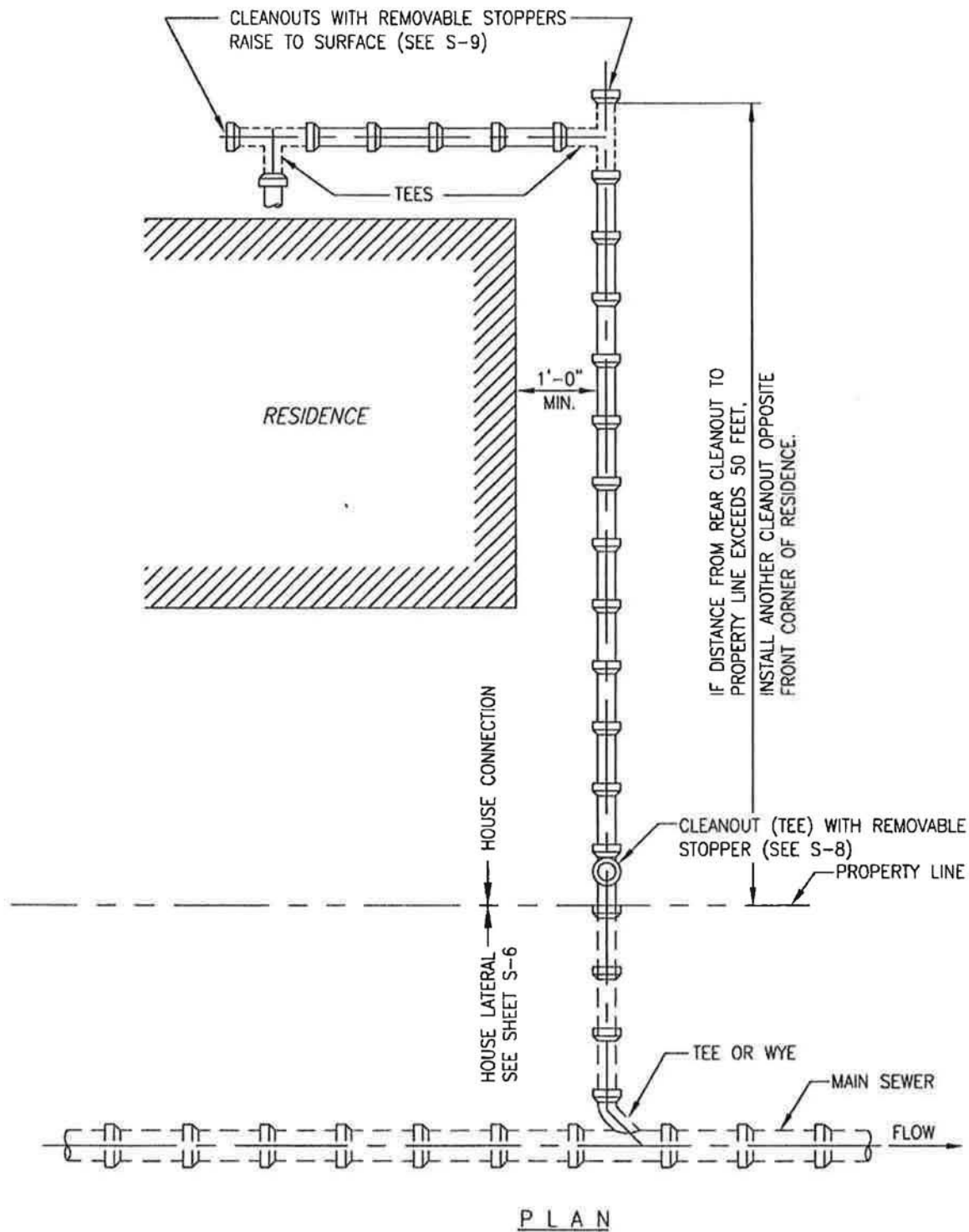

		<b>NIPOMO COMMUNITY SERVICES DISTRICT</b>	
		<b>TYPICAL HOUSE CONNECTION</b>	
<b>DATE</b>	<b>REVISION</b>	<b>DATE DRAWN</b> MARCH 2008	<b>SHEET NO.</b> <b>S-7</b>

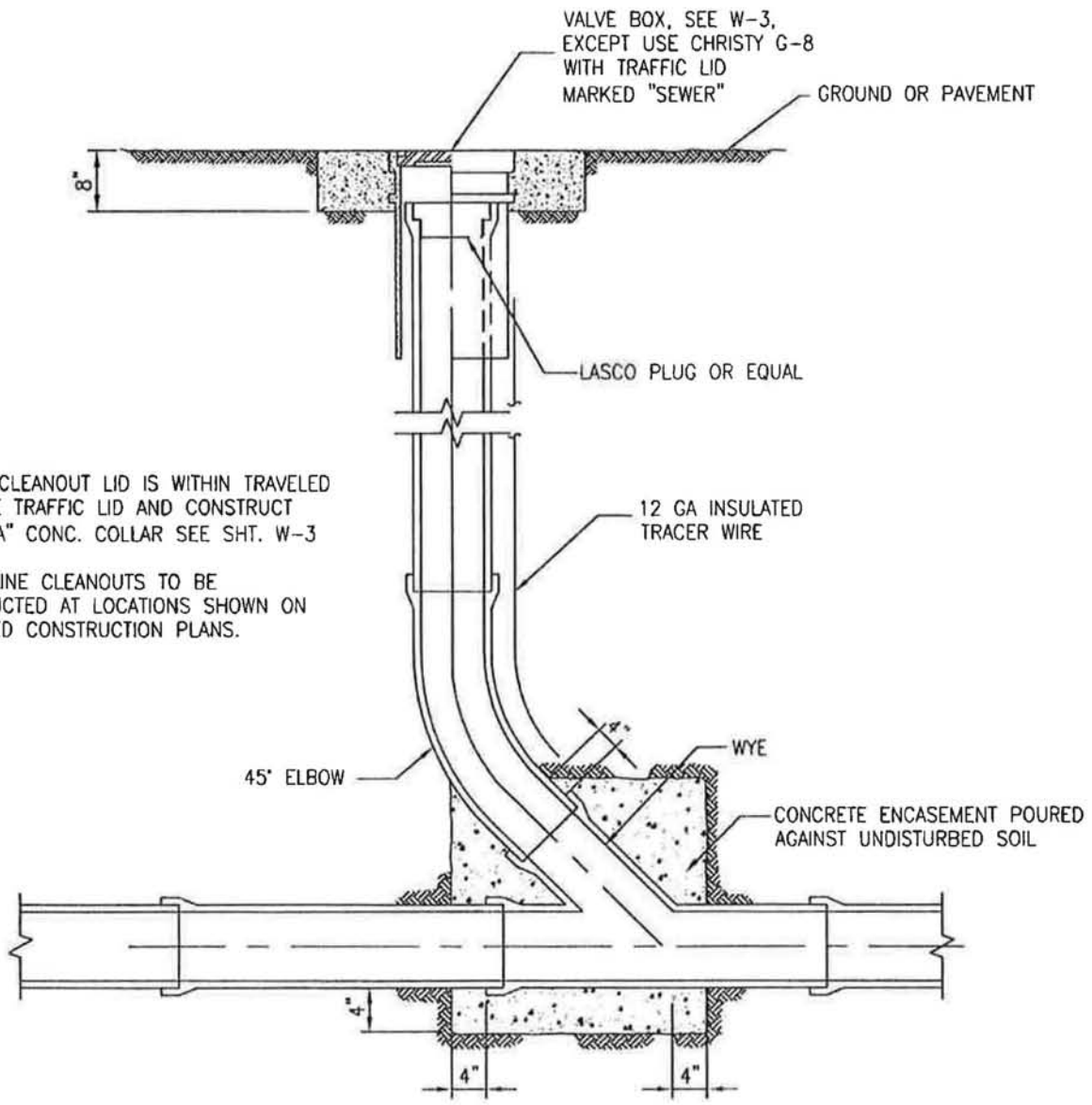

**NOTE:**

1. IF CLEANOUT LID IS WITHIN TRAVELED WAY USE TRAFFIC LID AND CONSTRUCT CLASS "A" CONC. COLLAR SEE SHT. W-3
2. INLINE CLEANOUTS TO BE CONSTRUCTED AT LOCATIONS SHOWN ON APPROVED CONSTRUCTION PLANS.

SECTION

		NIPOMO COMMUNITY SERVICES DISTRICT	
		INLINE CLEANOUT	
DATE	REVISION	DATE DRAWN MARCH 2008	SHEET NO. S-8

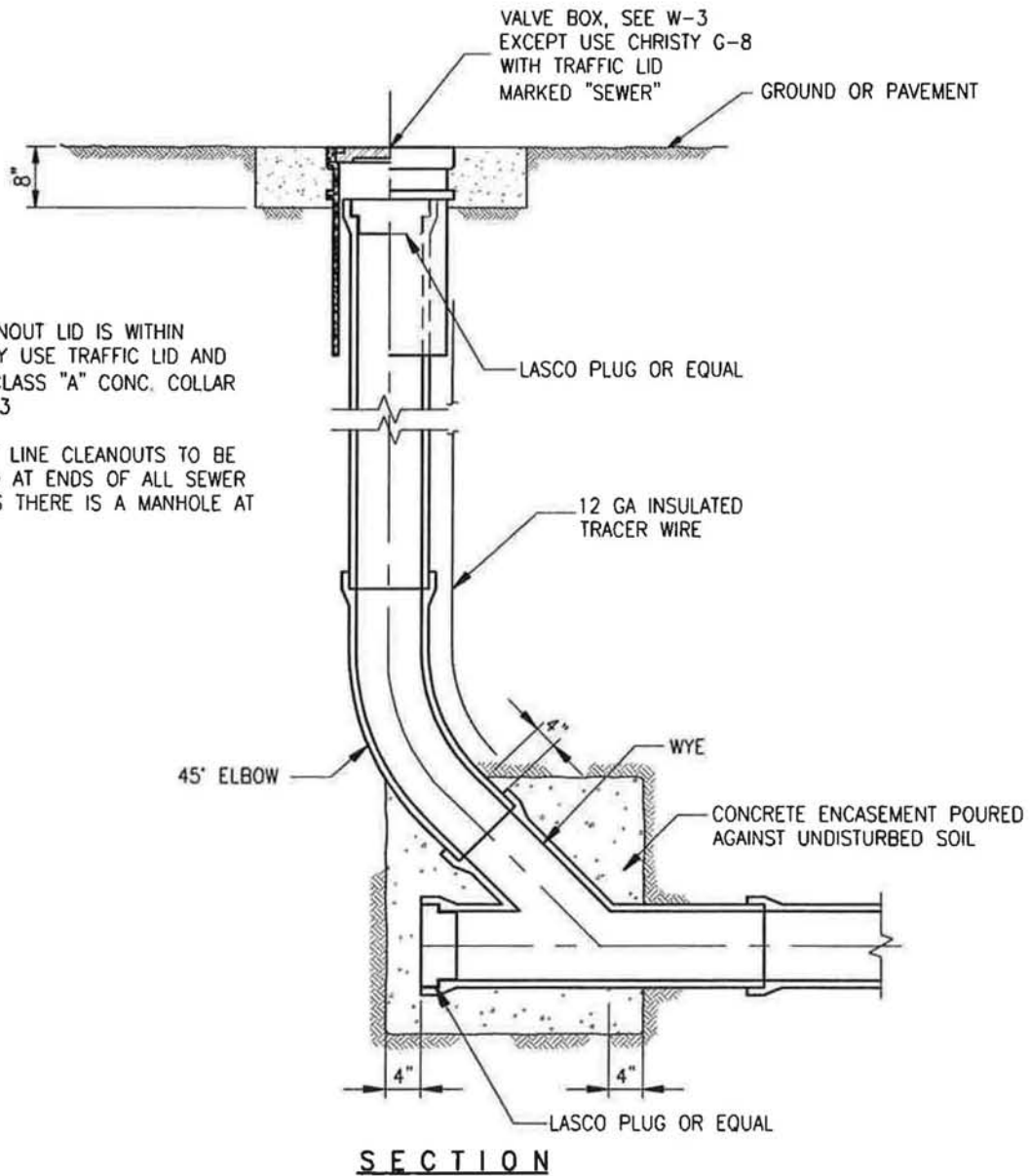

**NOTE:**

1. IF CLEANOUT LID IS WITHIN TRAVELED WAY USE TRAFFIC LID AND CONSTRUCT CLASS "A" CONC. COLLAR SEE SHT. W-3
2. END OF LINE CLEANOUTS TO BE CONSTRUCTED AT ENDS OF ALL SEWER LINES UNLESS THERE IS A MANHOLE AT THE END.

**SECTION**

		<b>NIPOMO COMMUNITY SERVICES DISTRICT</b>	
		<b>END OF LINE CLEANOUT</b>	
2010	ADDED WYE AND PLUG	DATE DRAWN	SHEET NO.
DATE	REVISION	MARCH 2008	<b>S-9</b>

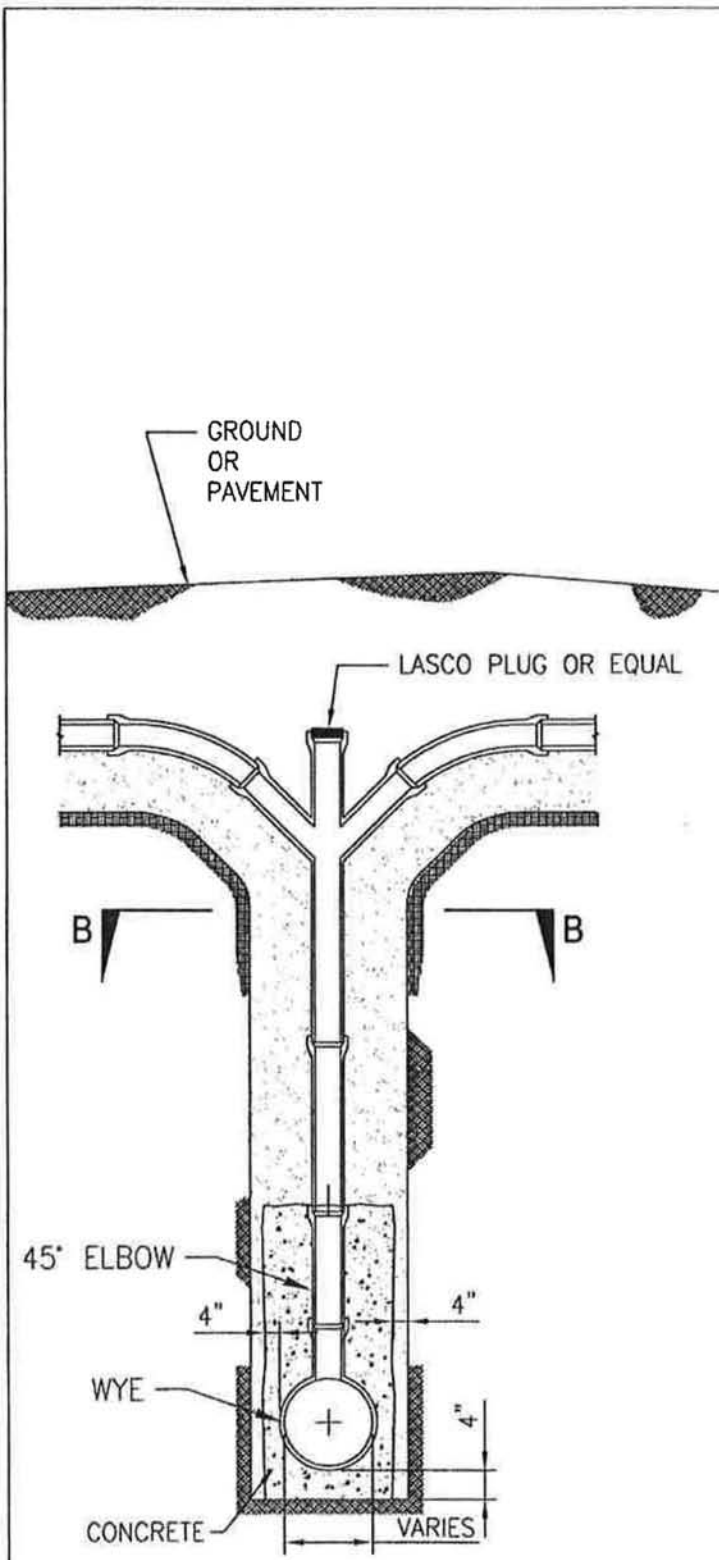

NOTE:  
SEWER LATERAL CHIMNEYS MAY ONLY  
BE USED ON DEEP SEWERS AND ONLY  
WITH THE PERMISSION OF THE DISTRICT.

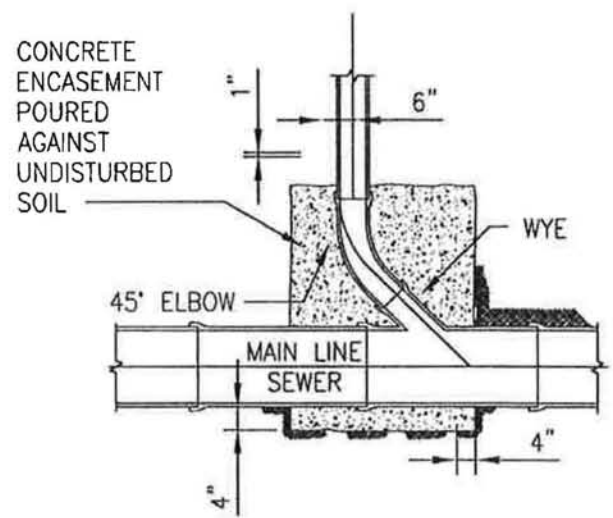

SECTION B-B

		<b>NIPOMO COMMUNITY SERVICES DISTRICT</b>	
		<b>SEWER LATERAL CHIMNEYS</b>	
DATE	REVISION	DATE DRAWN MARCH 2008	SHEET NO. <b>S-10</b>



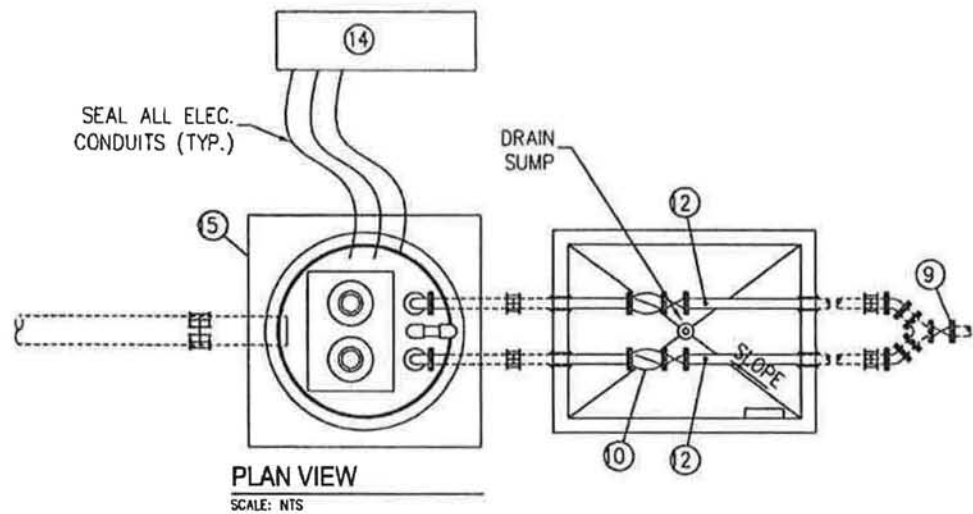

**GENERAL NOTES:**

- A. DEPTH FROM INLET TO FLOOR OF WET WELL SHALL BE 6' MINIMUM. GREATER DEPTH MAY BE REQUIRED DEPENDING ON SPECIFIC PROJECT REQUIREMENTS. WET WELL VOLUME REQUIREMENTS SHALL BE DETERMINED IN COORDINATION WITH THE DISTRICT.
- B. PREPARE BASE AND SUBGRADE FOR VAULT AND WET WELL IN CONFORMANCE WITH RECOMMENDATIONS FROM THE PROJECT SOILS REPORT.
- C. LIFT STATION LEVEL CONTROL TO BE PROVIDED BY SUBMERSIBLE TRANSDUCER WITH FLOAT BACKUP PER DISTRICT STANDARDS.

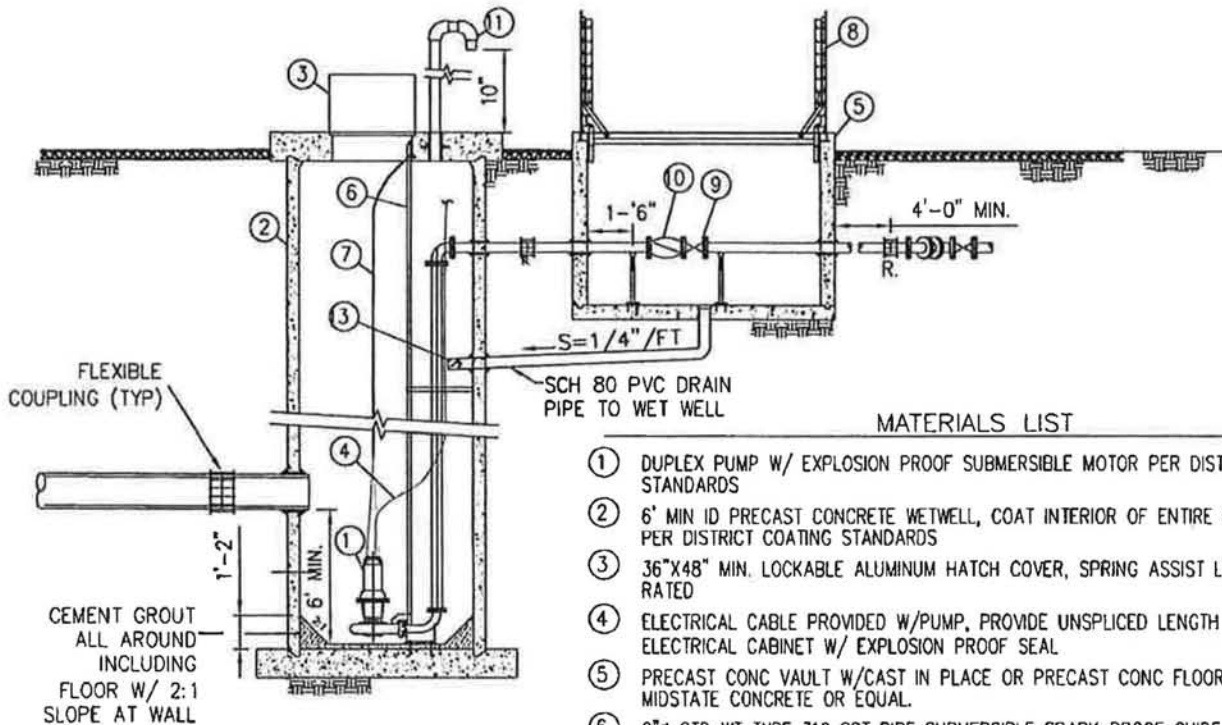

**MATERIALS LIST**

- ① DUPLEX PUMP W/ EXPLOSION PROOF SUBMERSIBLE MOTOR PER DISTRICT STANDARDS
- ② 6' MIN ID PRECAST CONCRETE WETWELL, COAT INTERIOR OF ENTIRE WET WELL PER DISTRICT COATING STANDARDS
- ③ 36"X48" MIN. LOCKABLE ALUMINUM HATCH COVER, SPRING ASSIST LID, H-20 RATED
- ④ ELECTRICAL CABLE PROVIDED W/PUMP, PROVIDE UNSPLICED LENGTH TO ELECTRICAL CABINET W/ EXPLOSION PROOF SEAL
- ⑤ PRECAST CONC VAULT W/CAST IN PLACE OR PRECAST CONC FLOOR AS MFG BY MIDSTATE CONCRETE OR EQUAL
- ⑥ 2"Ø STD WT TYPE 316 SST PIPE SUBMERSIBLE SPARK PROOF GUIDE RAIL SYSTEM COMPLETE W/GUIDE BRACKET
- ⑦ TYPE 3/8" SST LIFTING CHAIN, SIZE PER MFGS RECOMMENDATIONS
- ⑧ 6'x8' MIN. DOUBLE DOOR LOCKABLE ALUMINUM HATCH COVER W/ GASKETED SEAL & SPRING ASSIST LID, RATED H-20, BILCO, HALLIDAY PRODUCTS, OR EQUAL
- ⑨ PINCH VALVE, RED VALVE OR EQUAL
- ⑩ RUBBER FLAP CHECK VALVE, APCO WITH POSITION INDICATOR OR EQUAL FLOW DEVICE
- ⑪ 4"Ø MIN. SCREENED STAINLESS STEEL VENT PIPE
- ⑫ 1" TAP IN CENTER W/1" GALV PIPE NIPPLE AND 1" CAP IN D.I.P.
- ⑬ 4" PVC FLAP VALVE, RUBBER SEATED THREADED 6" FROM WET WELL ID
- ⑭ ELEC/CONTROL/SCADA/TELEMETRY PANELS
- ⑮ 8'-0" SQUARE MIN. CAST-IN-PLACE OR PRECAST CONCRETE SLAB

		<b>NIPOMO COMMUNITY SERVICES DISTRICT</b>	
		<b>TYPICAL DUPLEX SEWAGE LIFT STATION</b>	
		DATE DRAWN MARCH 2008	SHEET NO. S-11
DATE	REVISION		

# Appendix A

## Forms

---

**ENGINEER'S IMPROVEMENT CERTIFICATION FORM**  
**OFFER OF DEDICATION FORM**

**OFFER OF DEDICATION**

TO: NIPOMO COMMUNITY SERVICES DISTRICT  
P O BOX 326  
NIPOMO, CA 93444

The undersigned Owner(s) of \_\_\_\_\_  
(Tract or Project No.)

in the County of San Luis Obispo, hereby offers, and DEDICATES to the Nipomo Community Services District absolute and unencumbered ownership of the water and sewer improvements shown on the improvement plans for Tract/Project No.:

\_\_\_\_\_ approved by Nipomo Community Services District on \_\_\_\_\_.  
(Tract or Project No.) (Date)

(Owner/s)

By: \_\_\_\_\_  
(Name and Title)  
\_\_\_\_\_  
(Print Name)  
\_\_\_\_\_  
(Name and Title)  
\_\_\_\_\_  
(Print Name)  
  
\_\_\_\_\_  
(Date)

[Document requires notarization]

**ENGINEER'S IMPROVEMENT CERTIFICATION**

I, \_\_\_\_\_ R.C.E.No. \_\_\_\_\_, hereby  
certify that:

- A. I have regularly inspected, during construction, the water and sewer improvements ("Improvements") as shown on the Improvement Plans prepared by me and approved by the Nipomo Community Services District ("District") on \_\_\_\_\_, and with those approved changes shown  
(Date)  
on the record drawings prepared by me on \_\_\_\_\_, and  
(Date)  
approved by the District on \_\_\_\_\_.  
(Date)
  
- B. That said Improvements have been constructed at the horizontal and vertical alignment and in substantial conformance with the above referenced Improvement Plans.
  
- C. That said Improvements have been tested and meet District requirements, Standards and Specifications.

\_\_\_\_\_  
Signed

\_\_\_\_\_  
Print Name

Seal:

## **Appendix B**

# **Water Main Separation Requirements**

---

## Appendix B

### Water Main Separation Requirements

#### Water Main Separation Requirements in the California Waterworks Standards, Title 22, Division 4, Chapter 16, CCR.

##### §64572. Water Main Separation.

(a) New water mains and new supply lines shall not be installed in the same trench as, and shall be at least 10 feet horizontally from and one foot vertically above, any parallel pipeline conveying:

- (1) Untreated sewage,
- (2) Primary or secondary treated sewage,
- (3) Disinfected secondary-2.2 recycled water (defined in section 60301.220),
- (4) Disinfected secondary-23 recycled water (defined in section 60301.225), and
- (5) Hazardous fluids such as fuels, industrial wastes, and wastewater sludge.

(b) New water mains and new supply lines shall be installed at least 4 feet horizontally from, and one foot vertically above, any parallel pipeline conveying:

- (1) Disinfected tertiary recycled water (defined in section 60301.230), and
- (2) Storm drainage.

(c) New supply lines conveying raw water to be treated for drinking purposes shall be installed at least 4 feet horizontally from, and one foot vertically below, any water main.

(d) If crossing a pipeline conveying a fluid listed in subsection (a) or (b), a new water main shall be constructed no less than 45-degrees to and at least one foot above that pipeline. No connection joints shall be made in the water main within eight horizontal feet of the fluid pipeline.

(e) The vertical separation specified in subsections (a), (b), and (c) is required only when the horizontal distance between a water main and pipeline is less than ten feet.

(f) New water mains shall not be installed within 100 horizontal feet of the nearest edge of any sanitary landfill, wastewater disposal pond, or hazardous waste disposal site, or within 25 horizontal feet of the nearest edge of any cesspool, septic tank, sewage leach field, seepage pit, underground hazardous material storage tank, or groundwater recharge project site.

(g) The minimum separation distances set forth in this section shall be measured from the nearest outside edge of each pipe barrel.

(h) With Department approval, newly installed water mains may be exempt from the separation distances in this section, except subsection (f), if the newly installed main is:

- (1) less than 1320 linear feet,
- (2) replacing an existing main, installed in the same location, and has a diameter no greater than six inches more than the diameter of the main it is replacing, and
- (3) installed in a manner that minimizes the potential for contamination, including, but not limited to:
  - (A) sleeving the newly installed main, or
  - (B) utilizing upgraded piping material.

## **Appendix C**

# **Water Demand Rates and Peaking Factors**



## Appendix C

### Water Demand Rates and Peaking Factors

The Average Day Demand (ADD), Maximum Day Demand (MDD), and Peak Hour Demand (PHD) for proposed developments shall be estimated using the information provided below:

#### Demand Rates

Land Use Category	ADD per acre (gallons per day per acre)	Annual Demand Factor* (acre-feet per year per acre)
Agriculture	0	0.00
Commercial Retail	1,270	1.42
Commercial Service	310	0.35
Multi-Land Use Category	1,270	1.42
Office and Professional	230	0.26
Open Space	1,050	1.18
Public Facility	530	0.59
Recreation	870	0.98
Rural Lands	90	0.10
Residential Multi-Family	3,350	3.75
Residential Rural	180	0.20
Residential Suburban	870	0.98
Residential Single Family	1,870	2.10
Cañada Ranch Spec. Plan	1,750	1.96
Southland Specific Plan	870	0.98

(\*Source: Demand Database, NCSD 2010 Urban Water Management Plan, Table 13, page 23.)

#### Peaking Factors

Maximum Daily Demand (MDD)	1.70 x ADD
Peak Hourly Demand (PHD)	3.78 x ADD

(Source: Water and Sewer Master Plan Update 2007, page 2, Table ES-1.)

## **Appendix D**

# **Sewer Flow Rates and Peaking Factors**

---

## Appendix D

### Sewer Flow Rates and Peaking Factors

#### Design Sewer Flow Rates - Minimums for Residential Development

Minimum sewer flow rates from residential developments shall be the greater of (a) an average of 3.2 persons per single family residential unit at an average disposal rate of 60 gallons per person per day, or (b) the rates determined using the following table.

**Residential Sewer Flow Rates** (Source: *Water and Sewer Master Plan Update 2007, Technical Memorandum 1 - Water Demand and Sewer Load Projections, page 2, Table ES-2.*)

Land Use Category	Sewer Flow Rate (gallons per day per acre)
Residential Single Family	924
Residential Suburban	330
Residential Multi-Family	2634

#### Design Sewer Flow Rates - Minimums for Non-Residential Development

Minimum sewer flow rates from non-residential developments shall be determined using the following table.

**Non-Residential Sewer Flow Rates** (Source: *Water and Sewer Master Plan Update 2007, Technical Memorandum 1 - Water Demand and Sewer Load Projections, page 2, Table ES-2.*)

Land Use Category	Sewer Flow Rate (gallons per day per acre)
Commercial Retail	1064
Commercial Service	262
Office and Professional	195
Public Facility	442

For land uses not shown in the above table (e.g., commercial and industrial), the District shall determine flows based on the proposed project.

#### Peaking Factors

Peaking factors for sewer design shall be not less than 3.0 and shall be approved by the District.