

TO: BOARD OF DIRECTORS
FROM: MICHAEL S. LEBRUN *MSL*
GENERAL MANAGER
DATE: FEBRUARY 23, 2012

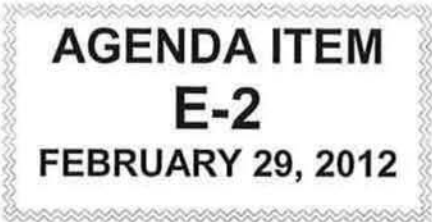

**REVIEW DRAFT ASSESSMENT ENGINEER'S REPORT AND DRAFT
BALLOT FOR SUPPLEMENTAL WATER PROJECT ASSESSMENT
DISTRICT FORMATION**

ITEM

Review draft Assessment Engineers Report and draft Ballot for Supplemental Water Project Assessment District Formation [RECOMMEND REVIEW DRAFT REPORT AND BALLOT, PROVIDE COMMENT, BY MOTION AND ROLL CALL VOTE DIRECT STAFF TO SCHEDULE APPROVAL OF ENGINEER'S REPORT ON MARCH 14, 2012 REGULAR MEETING AGENDA]

BACKGROUND

Pursuant to the provisions of the Municipal Improvement Act of 1913, being Division 12 of the Streets and Highways Code of the State of California (the "Improvement Act"), Part 7.5 of the Special Assessment Investigation, Limitation and Majority Protest Act of 1931, being Division 4 of the Streets and Highways Code of the State of California (the "Investigations Act"), Article XIID of the California Constitution ("Article XIID"), and the Proposition 218 Omnibus Implementation Act, being Article 4.6 of Chapter 4 of Part 1 of Division 2 of the Government Code of the State of California (the "Implementation Act"), and in connection with the financing, acquisition and construction of certain public improvements, together with appurtenances and appurtenant work in connection therewith, Kari E. Wagner, P.E. duly-authorized representative of Wallace Group, a California Corporation, is under contract with the District to develop and submit a report for the special assessment district known and designated as Nipomo Community Services District, Assessment District No. 2012-1 (Nipomo Mesa Supplemental Water Supply Project) Assessment District No. 1 (the "Assessment District").

Ms. Wagner has prepared a draft Engineer's Report supporting the formation of Assessment District No. 2021-1. The draft Report is attached for your Board's review. Ms. Wagner will be present to discuss the draft report and answer questions.

A draft Ballot and Notice for the proposed Assessment District is under-development as well. The draft Ballot is attached for Board review and comment. Bond Counsel drafted a Notice and this document is under review and further development by your Board's Ad Hoc Outreach Committee. The Engineer's Report, Ballot, and Notice are scheduled for review and approval by your Board on March 14, 2012.

FISCAL IMPACT

Staff time and professional consulting services related to supplemental water project development are included in the 2011-2012 budget. These costs are capitalized and included in the project cost and are recoverable following a successful financing vote.

STRATEGIC PLAN

Strategic Plan Goal 1.2 – Secure New Water Supplies

RECOMMENDATION

Staff recommends that your Honorable Board review the draft Report and Ballot, provide comment and staff direction, by motion and roll call vote direct staff to schedule approval of Engineer's Report and Ballot on March 14, 2012 Regular Meeting agenda.

ATTACHMENT

- DRAFT Engineer's Report, Proposed Assessment District No. 2012-1
- Draft Ballot

l:\board matters\board meetings\board letter\2012\120229 draft assessment engineers report.docx

DRAFT
Engineer's Report

For the
Nipomo Community Services District
Assessment District No. 2012-1
(Supplemental Water Project)

State of California



March __, 2012

Prepared by:

Wallace Group
a California Corporation
612 Clarion Court
San Luis Obispo, California 93401

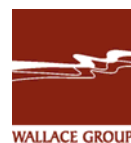

TABLE OF CONTENTS

Board of Directors and Staff Members -ii-

Certificates -iii-

Engineer’s Report 1

Introduction

Part I Preliminary Plans and Specifications 8

Part II Description of District and Improvements..... 9

Part III Estimate of Costs 13

Part IV Assessment Diagram 15

Part V Method of Assessment Apportionment 16

Part VI Assessment and Assessment Roll 36

Part VII Maximum Annual Administrative Assessment..... 36

Appendix A:

**NIPOMO COMMUNITY SERVICES DISTRICT
BOARD OF DIRECTORS**

James Harrison, President
Larry Vierheilig, Vice President
Michael Winn, Director
Ed Eby, Director
Dan A. Gaddis, Director

**NIPOMO COMMUNITY SERVICES DISTRICT
STAFF MEMBERS**

Michael S. LeBrun, P.E., General Manager
Lisa Bognuda, Assistant General Manager
Peter Sevcik, P.E., District Engineer
Jon Seitz, General Counsel

PROFESSIONAL SERVICES

Assessment Engineer
Wallace Group
a California Corporation

Financial Advisor
C.M. De Crinis & Co., Inc.

Bond Counsel
Fulbright & Jaworski, L.L.P.

CERTIFICATES

1. I, the Secretary of the Board of Directors of the Nipomo Community Services District, hereby certify that the enclosed Engineer's Report, together with the Assessment and Assessment Roll, in the amounts set forth in each, and with the Assessment Diagram attached hereto, was filed with me on _____, 2012.

By: _____
Michael S. LeBrun, P.E.,
Secretary of the Board of Directors

2. I, the Secretary of the Board of Directors of the Nipomo Community Services District, hereby certify that the enclosed Engineer's Report, together with the Assessment and the Assessment Diagram thereto attached received preliminary approval by the Board of Directors on _____, 2012, by Resolution No. _____.

By: _____
Michael S. LeBrun, P.E.,
Secretary of the Board of Directors

3. I, the Secretary of the Board of Directors of the Nipomo Community Services District, hereby certify that the enclosed Engineer's Report, together with the Assessment and the Assessment Diagram thereto attached was approved and confirmed by the Board of Directors on _____, 2012, by Resolution No. _____.

By: _____
Michael S. LeBrun, P.E.,
Secretary of the Board of Directors

4. I, the District Engineer of the Nipomo Community Services District, acting as the Superintendent of Streets, hereby certify that the enclosed Engineer's Report, together with the Assessment and the Assessment Diagram thereto attached was recorded in my office on _____, 2012.

By: _____
Peter Sevcik, P.E.,
District Engineer

NIPOMO COMMUNITY SERVICES DISTRICT
COUNTY OF SAN LUIS OBISPO, CALIFORNIA

ENGINEER'S REPORT

PURSUANT TO THE PROVISIONS OF DIVISION 12
OF THE STREETS AND HIGHWAYS CODE FOR THE
NIPOMO COMMUNITY SERVICES DISTRICT
ASSESSMENT DISTRICT NO. 2012-1
(SUPPLEMENTAL WATER PROJECT)

INTRODUCTION

Pursuant to the provisions of the Municipal Improvement Act of 1913, being Division 12 of the Streets and Highways Code of the State of California (the "Improvement Act"), Part 7.5 of the Special Assessment Investigation, Limitation and Majority Protest Act of 1931, being Division 4 of the Streets and Highways Code of the State of California (the "Investigations Act"), Article XIID of the California Constitution ("Article XIID"), and the Proposition 218 Omnibus Implementation Act, being Article 4.6 of Chapter 4 of Part 1 of Division 2 of the Government Code of the State of California (the "Implementation Act"), and in accordance with the Resolution of Intention passed and adopted on [REDACTED], 2012 by the Board of Directors of the Nipomo Community Services District (the "Resolution of Intention") in connection with the financing, acquisition and construction of certain public improvements, together with appurtenances and appurtenant work in connection therewith, Kari E. Wagner, P.E. duly-authorized representative of Wallace Group, a California Corporation, submits herewith the report for the special assessment district known and designated as Nipomo Community Services District, Assessment District No. 2012-1 (Supplemental Water Project) (the "Assessment District"), consisting of six parts as follows:

PART I

The **plans and specifications** for the proposed improvements sufficient to describe the general nature, location and extent of the improvements are as set forth in separate bid packages listed below on file in the Office of the District Engineer and are herewith made a part of this report.

- Bid Package #1 – Santa Maria River Crossing
- Bid Package #2 – Nipomo Area Pipeline Improvements
- Bid Package #3 – Blosser Road Waterline and Flow Meter
- Bid Package #4 – Joshua Road Pump Station and reservoir & Wellhead Chloramination Improvements

The improvements (the "Improvements") to be financed, constructed or acquired by the Assessment District are generally described as follows:

The Improvements, as part of the Supplemental Water Project, benefit each zone, as further provided in the methodology of assessment.

PART II

A **general description** of the improvements, rights-of way, and other property interests, if any, to be acquired is attached hereto and made a part hereof.

PART III

An **estimate of the cost** of the project, proposed improvements and of the cost of land, rights-or-way, and incidental expenses is attached hereto and is made a part hereof.

PART IV

The **assessment diagram** (hereinafter referred to as "Diagram") showing the exterior boundaries of the Assessment District, the exterior boundaries of any zones within the Assessment District and each parcel of land within the Assessment District is attached hereto and is made a part hereof. The location of the properties corresponding to the Assessment Numbers shown on the attached assessment roll can also be found on the Assessment Diagram. There are publicly-owned parcels to be assessed in the Assessment District.

PART V

A **description of the method of assessing costs** to the parcels in the Assessment District along with a list of parcels in the Assessment District and the assessments apportioned to those parcels (see Part VI) is attached hereto and made a part hereof.

PART VI

The **proposed assessment** of a portion of the costs and expenses of the proposed improvements in proportion to the estimated special benefits to be received by properties within each zone of the Assessment District, respectively, from said improvements, is set forth upon the **assessment roll** filed herewith and made a part hereof (the "Assessment Roll").

The Assessment Roll also includes the "Assessor APN" for each parcel which is the Assessor's Parcel Number corresponding to each property within the Assessment District as recorded in the San Luis Obispo County Assessor's Office.

Pursuant to the provisions of law and the Resolution of Intention, the costs and expenses of the have been assessed upon each of the parcels of land benefitted in direct proportion and relation to the estimated special benefits to be received by each of the parcels.

PART VII

A **proposed maximum annual assessment** upon each parcel to pay costs incurred by the Nipomo Community Services District resulting from the administration and collection of assessments and/or administration and registration of bonds and other funds.

DRAFT

PROPOSED ASSESSMENT

WHEREAS, on [REDACTED], 2012, the Board of Directors of the Nipomo Community Services District, California, pursuant to the provisions of the Improvement Act, Article XIIID and the Implementation Act, adopted its Resolution of Intention for the construction of the public improvements more particularly therein described;

WHEREAS, said Resolution directed the undersigned to make and file a report presenting a general description of any works and appliances already installed and any other property necessary or convenient for the operation of the improvements, preliminary plans for the proposed construction, preliminary estimate of costs, maps and general descriptions of lands to be acquired, and diagram, including zones, therein and assessment of and upon the subdivisions of land within the assessment district, to which Resolution and the description of said proposed improvements therein contained reference is hereby made for further particulars;

NOW, THEREFORE, the undersigned, by virtue of the power vested in me under the Improvement Act, Article XIIID and the Implementation Act and the order of the Board of Directors of the Nipomo Community Services District, hereby make the following assessment to cover the portion of the estimated costs of said acquisitions, work and improvements and the costs and expenses incidental thereto to be paid by the Assessment District.

The amount to be paid for said acquisitions, work and improvements, and the expenses incidental thereto, has been determined by the District assessment engineer of work for The Nipomo Mesa Supplemental Water Project and is summarized in the table, "Nipomo Mesa Supplemental Water Project Estimate of Costs".

**NIPOMO MESA SUPPLEMENTAL WATER PROJECT
 ESTIMATE OF COSTS**

Construction	
Construction	\$15,876,900
Construction Contingency (15%)	\$2,381,535
Total Construction	\$18,258,435
Engineering, Design and Incidental Costs	
Right of Way/Property Acquisition	\$360,000
Design Engineering	\$2,274,055
Contingency	\$688,233
Construction Management/Inspection	\$2,821,274
EIR Preparation	\$275,000
Total Design Costs	\$6,418,562
District Planning & Formation Costs	
Legal, Bond & Financial Costs	\$672,125
Engineering, Planning & Administration	\$912,000
Total District Formation Costs	\$1,584,125
Financing Costs & Reserves	
Capitalized Interest – 1 Year	\$1,460,393
Underwriter's Discount -1.5%	\$322,125
Bond Reserve Fund	\$1,719,674
Total Financing Costs & Reserve	\$3,502,192
TOTAL ALL COSTS	\$29,763,314
Contributions	
Dept. of Water Resources Contribution (Grant)	\$2,300,000
NCSD Contribution ¹	\$6,000,000
Total Contributions	\$8,300,000
TOTAL ASSESSMENT AMOUNT	\$21,463,314

¹ Contribution from capital charges accumulated by NCSD and allocated to Developed Property within Zone A.

And I do hereby assess and apportion said portion of said total amount of the cost and expenses of said project including acquisitions, work and improvements upon the zones, several lots, pieces or parcels or portions of lots or subdivisions of land liable therefore and benefited thereby, and hereinafter number to correspond with the numbers upon the attached Diagram, upon each, severally and respectively, in accordance with the special benefits to be received by such parcels, respectively, from the acquisitions and improvements, and more particularly set forth in the list hereto attached and by reference made a part hereof.

As required by the Improvement Act, Article XIID and the Implementation Act, an Assessment Diagram is hereto attached showing the Assessment District and also the boundaries of the respective Zones and parcels of land within said Zones of the Assessment District as the same existed at the time of the passage of the Resolution of Intention, each of which parcels having been given a separate number upon the Diagram.

Said assessment is made upon the parcels of land within the Assessment District and the Zones therein in proportion to the estimated special benefits to be received by said parcels, respectively, from said improvement. The Diagram and assessment numbers appearing herein are the diagram numbers appearing on the Diagram, to which reference is hereby made for a more particular description of said property.

Each parcel of land assessed is described within the Assessment Roll by reference to its assessor's parcel number as shown on the Assessor's Maps of the County of San Luis Obispo (the "County") for the fiscal year 2011-12 and includes all of such parcels excepting those portions thereof within existing public roads. For a more particular description of said property, reference is hereby made to the deeds and maps on file and on record in the office of the County Recorder of said County.

Notice is hereby given that serial bonds or term bonds or other financing instruments, to represent unpaid assessments and bear interest at the rate of not to exceed twelve percent (12%) per annum, or such higher rate of interest as may be authorized by applicable law at the time of sale of such bonds, will be issued hereunder in the manner provided by Division 10 of the Streets and Highways Code, the Improvement Bond Act of 1915 (the "1915 Act", and together with the Improvement Act, the Investigations Act, Article XIID and the Implementation Act, are collectively referred to herein as "Assessment Law"), and the last installment of such bonds shall mature not to exceed thirty (30) years from the second day of September next succeeding twelve (12) months from their date.

SPECIAL ASSESSMENT INVESTIGATION

Under the Resolution of Intention, the requirements of the Investigations Act shall be satisfied with Part 7.5 of the Investigations Act, for which the following is presented:

1. The total amount of the principal sum of the special assessments proposed to be assessed for the financing, construction and acquisition of the Nipomo Mesa Supplemental Water Project in the current proceedings is:

\$21,463,314

2. The total amount, as near as may be determined, of the total principal sum of all unpaid special assessments and special assessments requires or proposed to be levied under any completed or pending assessment proceedings, other than that contemplated in the instant proceedings, which would require an investigation and report under this division against the total area proposed to be assessed is: \$ [REDACTED].
3. The total true value, as near as may be determined, of the parcels of land and improvements which are proposed to be assessed is \$ [REDACTED]. Total true value may be estimated as the full cash value of the parcels as shown upon the last equalized assessment roll of the County.
4. The total value to lien ratio is approximately [REDACTED] to 1.00.

Based on the above, the undersigned does certify that the total amount of the principal sum of all unpaid special assessments levied against the parcels proposed to be assessed, plus the principal amount of the special assessment proposed to be levied in the instant proceedings, do not exceed one-half of the total truevalue of the parcels proposed to be assessed for the Assessment District.

The undersigned respectively submits the enclosed report as directed by the Board of Directors of the Nipomo Community Services District.

Dated this _____ day of _____, 20_____.

Kari E. Wagner, P.E.
RCE No. 66026, Expires 06-30-12
Wallace Group, a California Corporation

PART I

PRELIMINARY PLANS AND SPECIFICATIONS

The plans and specifications for the improvements for this Assessment District are voluminous and are not bound in this Engineer's Report. Reference is hereby made to the body of evidence and summary cost information contained within the preliminary design plans for the Nipomo Mesa Supplemental Water Project as four separate bid packages, which are as follows:

- Bid Package #1 – Santa Maria River Crossing
- Bid Package #2 – Nipomo Area Pipeline Improvements
- Bid Package #3 – Blosser Road Waterline and Flow Meter
- Bid Package #4 – Joshua Road Pump Station and reservoir & Wellhead Chloramination Improvements

Each set prepared by AECOM, previously referenced and incorporated as if attached to and part a part of this Engineer's Report, is on file in the Office of the District Engineer of the Nipomo Community Services District where they are available for inspection.

PART II

PROJECT DESCRIPTION

Background

The Santa Maria Valley Groundwater Basin has been the subject of ongoing litigation since July 1997. Collectively called the Santa Maria Groundwater Litigation (Santa Maria Valley Water Conservation District vs. City of Santa Maria, et al. Case No. 770214), over 1,000 parties were involved with competing claims to pump groundwater from within the boundary of the Santa Maria Valley Groundwater Basin.

On June 30, 2005, the Court entered a Stipulated Judgment ("Stipulation") in the case. The Stipulation divides the Santa Maria Valley Groundwater Basin into three separate management sub-areas (the Northern Cities Management Area, the Nipomo Mesa Management Area (NMMA), and the Santa Maria Valley Management Area). The Stipulation contains specific provisions with regard to rights to use groundwater, development of groundwater monitoring programs, and development of plans and programs to respond to Potentially Severe and Severe Water Shortage Conditions.

The Technical Group (TG) was formed pursuant to a requirement contained in the Stipulation. Sections IV D (All Management Areas) and Section VI (C) (Nipomo Mesa Management Area) contained in the Stipulation were independently adopted by the Court in the Judgment After Trial (herein "Judgment"). The Judgment is dated January 25, 2008 and was entered and served on all parties on February 7, 2008.

The provisions in the Stipulation regarding supplemental water provide in relevant part:

"The NCSD agrees to purchase and transmit to the NMMA a minimum of 2,500 acre-feet of Nipomo Supplemental Water each Year. However, the NMMA Technical Group may require NCSD in any given Year to purchase and transmit to the NMMA an amount in excess of 2,500 acre-feet and up to the maximum amount of Nipomo Supplemental Water which the NCSD is entitled to receive under the MOU if the Technical Group concludes that such an amount is necessary to protect or sustain Groundwater supplies in the NMMA. The NMMA Technical Group also may periodically reduce the required amount of Nipomo Supplemental Water used in the NMMA so long as it finds that groundwater supplies in the NMMA are not endangered in any way or to any degree whatsoever by such a reduction".

"Once the Nipomo Supplemental Water is capable of being delivered, those certain Stipulating Parties listed below shall purchase the following portions of the Nipomo Supplemental Water Yearly:

Nipomo Community Services District - 66.68%
Woodlands Mutual Water Company - 16.66%
Golden State Water Company² - 8.33%
Rural Water Company - 8.33%”

The final Judgment entered on January 24, 2008, states: “The court approves the Stipulation, orders the Stipulating Parties only to comply with each and every term thereof, and incorporates the same herein as though set forth on full.”

The NCSD developed the Supplemental Water Project to bring supplemental water to the above referenced Stipulating Parties within the NMMA. The Supplemental Water Project involves the construction of approximately five miles of new water main to transport up to 3,000 AF of new water from the City of Santa Maria to the Nipomo Community Services District and the other Stipulating Parties. In summary, the Judgment mandates the financing, construction and acquisition of the Supplemental Water Project and has apportioned among the Stipulating Parties the allocation of the costs and benefits of the financing, construction and acquisition of the Supplemental Water Project. Therefore, the parcels within the boundaries of each Stipulating Party will be treated as a separate zone with the Assessment District and the special benefits afforded to each parcel therein as determined by the Assessment Engineer in conjunction with the determination established by the Judgment.

Project Description

The Nipomo Mesa Supplemental Water Project consists of over 27,000 linear feet (LF) of pipeline, a 0.5 million gallon (MG) storage tank, a 2,000 gallon per minute (gpm) pump station, and chloramination systems at the pump station and at four existing Nipomo Community Services District production wells, as well as the related back-up power, controls, power supply and instrumentation. The Supplemental Water Project is an integrated approach to the mandate of the Judgment and is to be viewed as a single project benefitting the zones in the manner allocation described in the Judgment. The Supplemental Water Project shall be constructed, owned and operated by the Nipomo Community Services District. The Nipomo Community Services District completed the Concept Design in April 2009 (Nipomo Waterline Intertie Project, Concept Design Report, AECOM). The report is available for viewing at the Nipomo Community Services District office and for download on the Nipomo Community Services District's website.

² The proceedings reference Golden State Water Company in its previous name, Southern California Water Company.

Transmission Pipeline

The waterline design begins at the north end of the City of Santa Maria water distribution system at the intersection of Blosser Road and West Taylor Street with a new 18-inch waterline (24-inch bid option available). The waterline runs north along Blosser Road to Atlantic Place and transitions to a 24-inch waterline to cross underneath the Santa Maria River levee. The 24-inch line will be installed underneath the levee and will cross under the Santa Maria River utilizing horizontal directional drilling technology, ending atop the Nipomo Mesa. From the end of the horizontal directional drill, a 24-inch pipeline will be installed via open trench construction to the reservoir.

Reservoir

On the Nipomo Mesa, the 24-inch pipeline will connect to a 500,000-gallon, pre-stressed concrete reservoir. The reservoir will be partially buried to assist the delivery of water via City of Santa Maria system pressures (without pumping). The primary reason for a partially buried tank is to eliminate the need for a pump station in Santa Maria. However, a secondary benefit to the partially buried tank design is that it will reduce visual impacts. The partially buried tank is designed with the bottom of the tank at approximately 22 feet below grade. Approximately 3 to 6 feet of tank wall will be visible above grade. "Native" colors will be selected for the tank color.

Booster Pump Station

The booster pump station consists of three vertical turbine pumps and associated controls. The pumps will draw water from the reservoir and deliver it at flows ranging from 600 gallons per minute (gpm) to up to 2,000 gpm. A 24-inch pipeline will be installed to connect the pump station to an existing 12-inch waterline. Water will be pumped along Orchard Road (in the existing 12-inch waterline) and branch into new dedicated pipelines that connect to the main Nipomo Community Services District system in several locations.

NCSD System Pipeline Improvements

Dedicated 12-inch waterlines will be installed to deliver water to the system's back-bone transmission mains in order to protect smaller existing waterlines and users from high pressures. These dedicated mains will be in five areas: 1) along Orchard Road, from Southland Street to Grande Street; 2) along Southland Street, from Orchard Road to Frontage Road; 3) along Frontage Road from Southland Street to Grande Street; 4) from Grande Street, northeast underneath Highway 101 to Darby Lane, continuing on Darby Lane to South Oakglen Avenue; and 5) along South Oakglen Avenue from Darby Lane to Tefft Street. The dedicated mains will connect to the existing system at Orchard Road and Grande Street, Frontage Road and Grande Street, and South Oakglen Avenue and Tefft Street.

Pressure Reducing Valve Stations

Pressure-reducing-valve (PRV) stations will protect downstream users from high pressures required for the supplemental water delivery. Five PRV stations will be installed around the Nipomo Community Services District's system. One will be placed on Santa Maria Vista Way near the connection to the existing 12-inch waterline, lowering pressure for the Maria Vista Development. Three stations will be placed strategically to create a separate pressure zone in the southwest region of the Nipomo Community Services District's system (on Grande Street, on Orchard Road, and on Oakglen Avenue). The fifth PRV station will be installed on Southland Street between the dedicated main and an existing waterline to allow high flows into the new pressure zone during an emergency (low pressure) situation.

Chloramination Disinfection Conversion

The project includes conversion of four production wells from chlorination to chloramination systems and a booster chloramination system at the pump station. The Preliminary Engineering Memorandum (Boyle/AECOM, May 2008) contains a detailed discussion of the project's disinfection options and water quality issues, and recommends the conversion to match the disinfection process of the supplemental water.

The Nipomo Community Services District will install chloramination equipment at Sundale, Eureka, Via Concha, and Blacklake #4 wells. Production records indicate that these four wells, along with the Bevington or Knollwood Well (if a chloramination system is installed in the future) should produce sufficient water to meet the year 2007 maximum daily demand of 3,152 gpm (4.5 MGD). Other wells could be on standby until such time as they were needed, or they could be operated periodically, using a portable chloramination system.

Land and Easements

To complete the Project it is estimated that [REDACTED] acres property will need to be acquired for [REDACTED]. The cost of the property acquisition as well as the costs of preparing the plats and legal description are necessary for the Project and are included in the cost estimate.

Incidental Expenses

Incidental expenses proposed to be included as part of the assessment include costs related to, but not limited to, planning, design engineering, construction engineering, right-of-way engineering, assessment engineering, bond counsel, financial advising, construction management, construction administration, environmental mitigation, soils testing, bond issuance, capitalized interest and contingencies. The expenses are incidental and necessary to accomplish the works of improvement.

PART III

ESTIMATE OF COSTS

An estimate of the cost of the proposed improvements for the Nipomo Mesa Supplemental Water Project and of the cost of lands, rights-of-way, and incidental expenses is shown in the table below "Nipomo Mesa Supplemental Water Project Estimate of Costs". The estimated cost is based on the 90% plan set and engineer's opinion of probable cost prepared by AECOM in December 2011 and additional input from Nipomo Community Services District Staff on incidental expenses also provided in December 2011.

The Nipomo Community Services District has received a grant from the State Water Board in the amount of \$2,300,000 to offset the cost of the Project and as a contribution for general benefit should any be determined to exist. Additionally, within Zone A, developed properties have been charged a facility fee which Nipomo Community Services District shall contribute to the cost of the Project for the specific benefit and allocation to such properties within Zone A.

The annual operation, maintenance and replacement cost will not be funded by the proposed Assessment District. Instead, the Nipomo Community Services District will fund such costs from rates and charges and the revenue derived from the sale of supplemental water to water purveyors within the Assessment District.

**NIPOMO MESA SUPPLEMENTAL WATER PROJECT
 ESTIMATE OF COSTS**

Construction	
Construction	\$15,876,900
Construction Contingency (15%)	\$2,381,535
Total Construction	\$18,258,435
Engineering, Design and Incidental Costs	
Right of Way/Property Acquisition	\$360,000
Design Engineering	\$2,274,055
Contingency	\$688,233
Construction Management/Inspection	\$2,821,274
EIR Preparation	\$275,000
Total Design Costs	\$6,418,562
District Planning & Formation Costs	
Legal, Bond & Financial Costs	\$672,125
Engineering, Planning & Administration	\$912,000
Total District Formation Costs	\$1,584,125
Financing Costs & Reserves	
Capitalized Interest – 1 Year	\$1,460,393
Underwriter's Discount -1.5%	\$322,125
Bond Reserve Fund	\$1,719,674
Total Financing Costs & Reserve	\$3,502,192
TOTAL ALL COSTS	\$29,763,314
Contributions	
Dept. of Water Resources Contribution (Grant)	\$2,300,000
NCSD Contribution ³	\$6,000,000
Total Contributions	\$8,300,000
TOTAL ASSESSMENT AMOUNT	\$21,463,314

³ Contribution from capital charges accumulated by NCSD and allocated to Developed Property within Zone A.

PART IV

ASSESSMENT DIAGRAM

The Assessment District is divided into four (4) separate zones, each zone corresponding to the boundaries or service areas of the following water purveyors: Nipomo Community Services District – Zone A, Golden State Water Company – Zone B, Rural Water Company – Zone C, and Woodlands Mutual Water Company – Zone D. The boundaries of the proposed Assessment District, including the zones, are as established by the Board of Directors of the Nipomo Community Services District with its Resolution of Intention adopted on ____, 2012, and are incorporated herein by reference.

The lines and dimensions of each lot or parcel within each Zone within the Assessment District are those lines and dimensions shown on the maps of the Assessor of the County of San Luis Obispo for the year when this Engineer's Report was prepared, and are incorporated by reference herein and made part of this Engineer's Report. The Diagram for the Assessment District is shown in a separately bound document which is on file with the Secretary of the Board; said material being too bulky to be bound with this Engineer's Report. The Proposed Boundary/Diagram are shown in a reduced scale format as Exhibit "A".

The Proposed Boundary Map was recorded on _____, 2012 in Book _____, Pages _____, Recording Number _____, in the office of the County Recorder of the County San Luis Obispo, State of California.

The Diagram was recorded on _____, 2012 in Book _____, Pages _____, Recording Number _____, in the office of the County Recorder of the County San Luis Obispo, State of California.

PART V

METHOD OF ASSESSMENT APPORTIONMENT

A. BACKGROUND

The law requires that assessments imposed pursuant to Assessment law be based on the special benefit properties receive from the works of improvement. However, the law does not specify the method or formula that should be used to apportion the assessments in assessment district proceedings. In addition, Article XIID requires that only special benefits are assessable, that no assessment may exceed the proportional special benefit conferred on the parcel assessed, and that publicly-owned parcels shall not be exempt from the assessment unless clear and convincing evidence demonstrates that such publicly-owned parcels receive no special benefits from the improvements for which the improvements are imposed. Special Benefit is a particular and distinct benefit over and above general benefits conferred on real property located in the Assessment District or to the public at-large. General enhancement of property does not constitute special benefit.

It is necessary to identify the special benefit that the works of improvement will render to the properties within each Zone within the Assessment District. It is also necessary that the properties receive a special and direct benefit as distinguished from benefit to the general public.

The Assessment Engineer is appointed for the purpose of analyzing the facts and determining the method or formula for apportionment of the assessment obligation to the benefited properties. For these proceedings, Nipomo Community Services District retained the firm of The Wallace Group as the Assessment Engineer.

The Assessment Engineer makes his or her recommendation for the method of apportionment of the improvement at the public hearing. The final authority and action rests with the Board of Directors after hearing all testimony and evidence presented at the public hearing and the tabulation of the assessment ballots. Upon conclusion of the public hearing, the board of Directors must make the final action in determining that the assessment has been made in direct proportion to the special benefit received. Ballot tabulation will then be completed, and if a majority protest, weighted by assessment amount, do not protest the assessment, then the Board of Directors may establish the Assessment District.

GENERAL BENEFIT

The Project may convey public general benefit or special benefit beyond the properties within the Assessment District or to exempt properties within the Assessment District. All properties outside of the boundaries of the Assessment District or those exempt with the Assessment District are subject, however, to Ordinance No. 3090 of the County of San Luis Obispo, which requires parcels within the Nipomo Mesa Water Conservation Area with general plan amendments or land divisions to off-set their impact and need for supplemental water by paying a supplemental water development fee that will increase, not supplant the existing supplemental water provided by the Project. Any general benefit of lessening the threat of seawater intrusion into the fresh water supply or special benefit to properties not covered by Ordinance No. 3090,

has been quantified to be much less than the contribution provided by the State water grant in the amount of \$2,300,000.

SPECIAL BENEFIT

In making the special benefit analysis, it was necessary to first identify the special and general benefits that the work of improvements render to the properties within the Assessment District and to determine that the zones, and the properties within the zones, receive a direct and special benefit distinguished from that of the general public. The special benefit for each zone has been measured in the quantity of the supplemental water available. The special benefit to each property within the zone, as a result of the construction of the work of improvements, is the ability of each property to have reliable sources of fresh water and available supplemental water and so that the threat of seawater intrusion from over-pumping the current fresh water supply is avoided.

The properties within the Assessment District are only parcels that will receive a special benefit from the work of improvements. The work of improvements provide special benefit for each property within the Zones which are part of a service area to a water purveyor and are subject to or benefit by the availability of the supplemental water provided by the work of improvements. The improvements are for the use and benefit of the properties within the Assessment District only and will not serve or directly benefit the general public. Additionally, the improvements have been sized for the benefit of the properties within the Assessment District and does not contain additional capacity which would allow other areas to use the improvements without an additional cost and addition to the improvements.

GENERAL DESCRIPTION OF METHOD

All properties that stand to benefit from the construction of the Nipomo Mesa Supplemental Water Project, public or private, vacant or occupied, subdivided or un-subdivided, have been assessed a portion of the project costs. The benefits to an individual parcel are based on its service location, zoning, size, use of the property, whether it is currently developed, and its development potential. First, the proposed Assessment District is broken into four zones based on the boundaries of each water purveyor's water system boundary or service area: Nipomo Community Services District (NCSD) – Zone A, Golden State Water Company (GSWC) – Zone B, Rural Water Company (RWC) – Zone C, and Woodlands Mutual Water Company (WMWC) – Zone D. Each zone has a different share in the total project costs based on their percentage established in the Stipulation noted in Part III of this Engineer's Report, which apportionment and rationale has been reviewed by the Assessment Engineer and in which the Assessment Engineer concurs. Apportionment of the costs of the Project for each zone is based on the percentage of the projected quantity of available water due to the construction of the Project for such zone in relationship to the other zones' quantity of available water and constitutes the special benefit for such zone. The following Table, "Nipomo Mesa Supplemental Water Project Apportioned Project Costs", provides a breakdown of the share for Zone and their financial share of the proposed project.

**Nipomo Mesa Supplemental Water Project
 Apportioned Project Costs**

Zone	Percentage of Share¹ (%)	Water Supply² (acre-ft)	Additional Water Supply Requested (acre-ft)	Equivalent Percentage Based on 3,000 acre-ft³ (%)	Project Cost (\$)
Zone A	66.68%	1,667	500	72.23%	13,186,314
Zone B	8.33%	208	0	6.94%	2,086,047
Zone C	8.33%	208	0	6.94%	2,086,047
Zone D	16.66%	417	0	13.88%	4,104,906
Total	100.00%	2,500	500	100.00%	21,463,314

¹ Percentage based on stipulation agreement for 2,500 acre-feet of water.

² The amount of water supply for each zone based on a percentage of 2,500 acre-ft.

³ The equivalent percentage for each zone based on 3,000 acre-feet of water. This percentage will be used to calculate distributed cost to each zone.

Once a cost estimate and special benefit has been determined for a zone, then the further special benefit for each parcel is determined based on several factors for the parcel including its zoning, size, use of the property, whether it is currently developed, and its development potential. Although there are four (4) zones included in the same Assessment District, the governing codes and ordinances to determine the development potential, and thereby the method of assessment is different for each zone. The methods used for determining development potential for this Assessment District are as follows:

Development Potential Determination

To determine the number of potential lots for each vacant or underdeveloped property, reference was made to the Land Use Element and Land Use Ordinance provided by the San Luis Obispo Planning and Building Department. The South County Area Plan is the part of the County's Land Use Plan covering the Nipomo area. Various "Planning Areas" as designated in the Land Use Element are associated with particular minimum lot sizes within each group. Each are described in more detail below for each water purveyor's boundary.

ZONE A

There are 4,589 parcels within Zone A. The parcels are governed by the following current land use policies as of the date of this report:

- San Luis Obispo County Land Use Ordinance Title 22
- South County Planning Area Standards Chapter 22.112
- Black Lake Specific Plan
- Resource Management System Policies

The development potential for the parcels within Zone A are based on the evaluation of the assumptions and thresholds of water use and availability identified in a report prepared by Wallace Group for Nipomo Community Service District on April 15, 2009 and is provided in Appendix **1**. The following are various ordinances and assumptions used to determine development potential for all parcels within Zone A:

- Residential single family (RSF) parcels 12,000 square foot (sf) in size are potentially allowed by ordinance to subdivide to 6,000 sf lots. For parcels less than or equal to 2.0 acres, if a residential unit is existing, it was assumed that the parcel would not subdivide and was only assessed based on its existing use. For parcels greater than 2.0 acres, the parcel was assessed for its full development potential, based on its ability to subdivide.
- Residential single family lots of less than 6,000 sf do not have secondary dwelling unit capability.
- Residential parcels less than 2.0 acres on septic systems do not have secondary dwelling unit capability.
- Black Lake residential parcels do not have secondary dwelling unit capability, regardless of parcel size.
- Residential Multi-Family (RMF) parcels do not have secondary dwelling unit capability, regardless of parcel size.
- Minimum lot size for an existing legally created lot to establish a single family residence is 1,750 sf.
- Minimum newly created lot size in Agriculture (AG) zoning is 20 acres.
- Minimum newly created lot size in Residential Rural (RR) zone is 5 acres.
- Minimum newly created lot size in Residential Suburban (RS) is 1 acre.
- Minimum newly created lot size in RSF is 6,000 sf, except where density is dictated by the Area Plan standards or where limited by wastewater service.
- Development potential for parcels with split zoning will be evaluated per Section 22.02.020.D, and/or in consult with County of San Luis Obispo staff.

Zone B

There are **1,488** parcels within Zone B. The parcels are governed by the following current land use policies as of the date of this report:

- San Luis Obispo County Land Use Ordinance Title 22
- South County Planning Area Standards Chapter 22.112
- Resource Management System Policies

The development potential for the parcels within Zone B are based on the evaluation of the assumptions and thresholds of water use and availability identified in a report prepared by Wallace Group for Nipomo Community Service District on April 15, 2009 and is provided in Appendix [redacted] and described above under the Development Potential for Nipomo Community Services District. The following are additional assumptions made specifically for Zone B parcels:

- All lots outside of Specific Plan areas are assumed to be on septic systems for density purposes, with exceptions as noted. Regardless of zoning and lot size, for properties on septic, a secondary unit requires 2 acres minimum. Where properties are on community sewer, the secondary unit is allowed on each existing lot over 6,000 square feet, or on any potential lot that could be created by subdivision at the required minimum lot size.
- Minimum newly created parcel in Rural Lands (RL) is 20 acres.

Zone C

There are 1,073 parcels within Zone C. Zone C includes Cypress Ridge, a master planned community governed by the Cypress Ridge Specific Plan. Zone C also includes parcels outside of Cypress Ridge. The parcels are governed by the following current land use policies as of the date of this report:

- San Luis Obispo County Land Use Ordinance Title 22
- South County Planning Area Standards Chapter 22.112
- Resource Management System Policies

The development potential for the parcels within Zone C are based on the evaluation of the assumptions and thresholds of water use and availability identified in a report prepared by Wallace Group for Nipomo Community Service District on August 19, 2009 and is provided in Appendix [redacted]. The following are some assumptions made specifically for Zone C parcels:

- Cypress Ridge has sewer service; all parcels outside of Cypress Ridge are assumed to be on septic.
- Residential parcels less than 2.0 acres on septic systems do not have secondary dwelling unit capability.
- The resort site has an existing golf club and restaurant. There is an approved Vesting Tentative Tract Map for a new hotel condo resort with restaurant which includes 7 residential lots at Brant and Tattler. These lots are being graded for residential sale, and will not be part of the resort.
- The resort will be redesigned to fit the smaller area. The allowed resort uses are:
 - Hotel up to 103 units
 - 14,000 sf footprint for hotel registration & lobby, restaurant (200-seat max), pro shop.
- The Cypress Village Center allows for a sports facility (swim & tennis center), a community resource (common building) center, and limited office/retail services. The sports center has yet not been constructed.
- Development potential for all parcels, excluding parcels within the Cypress Ridge Specific Plan, is based on the assumptions and thresholds identified for Nipomo Community Services District, stated above.

Zone D

Zone D is allowed a maximum of 1,320 dwelling units, inclusive of secondary units per the Woodlands Specific Plan. Not all primary units are built, but Phase 1 lots are "assumed built". Secondary units are allowed on lots over 6,000 sf. within the maximum limit of 1,320 dwelling units total for the entire planned community.

For Zone D's Commercial Mixed Use (at the Village Center) which is vacant, the maximum floor area allowed under the Specific Plan for all Commercial Retail (CR) lots is provided. The Mixed Use allows up to 80 units per the Specific Plan. Per the Conditional Use Permit, the Village Center will have 20 units. The Assessment District will assume 20 units will be constructed.

The use of the Business Park is authorized to be converted with a Specific Plan Amendment to retail or residential uses. If residential is proposed, it still cannot exceed the 1,320 dwelling units maximum.

For Zone D Commercial Services (CS) zoned lots (all of which are vacant), the Floor Area Ratio (FAR) maximum of 0.35 was used to calculate the maximum development per lot. It turns out that the FAR per each of the 19 lots totals 284,000, considerably less than the overall allowed maximum of 350,000 sf, leaving some potential commercial floor area on the table in Phase II.

The various open space lots are identified within the spreadsheet as follows:

Easement Open Space:

- Easements providing access to the golf course are "access easements"
- Easements acting as open space buffers between development are "buffer lots"
- Buffer easements along the perimeter are identified as "buffer & trail"
- Pocket park lots are called "park open space"
- The Butterfly habitat is "habitat open space"

APN 091-500-016 includes all of Phase 2A and 2B.

BENEFIT UNIT DETERMINATION

Each property that stands to obtain a special benefit from the Nipomo Mesa Supplemental Water Project has been assigned a "benefit unit", or share in the overall cost of the project or special benefit derived from the project. The cost for a benefit unit will be different for each Zone as each Zone has a different share in the project. Within each Zone, special benefits are proportional to the special benefits received by the individual parcel in relation to the special benefits received by the other parcels in the Zone, based on the quantity and availability of water due to the Nipomo Mesa Supplemental Water Project, its zoning designation, use, size and/or current or potential development use. Within the Assessment District, there are various land uses such as single family residences, multiple family residences, commercial retail property, open space, etc. The method of assigning benefit units to each of these land uses is different for each area and is described in more detail as follows.

Zone A

The Basis of Assessment for Zone A is summarized in "Zone A Basis of Assessment" table. A full description of each group in this table is as follows:

Group 1: Residential with One Unit

This group includes all residential properties, including Land Use Categories Residential Single Family, Residential Multi-Family, Residential Rural, Residential Suburban, and Rural Lands with only one unit. The following parameters were used to determine benefit unit assignments:

- Developed parcels less than or equal 2.0 acres – Parcels were only assessed for their existing use and were not assessed for their full development potential if capable of subdividing or adding an additional granny unit.
- Developed parcels greater than 2.0 acres – Parcels were assessed for their existing development in addition to the parcels full development potential.
- Vacant parcels (any size) – Vacant parcels were assessed for their full development potential.

Group 2: Residential with Two Units

This group includes all residential properties, including Land Use Categories Residential Single Family, Residential Rural, Residential Suburban, and Rural Lands with a second unit. The following parameters were used to determine benefit unit assignments:

- The first unit is assessed per Group 1.
- Developed parcels with 2 units – Parcels less than or equal to 1.0 acre with a second unit are not assessed for the secondary unit. Parcels greater than 1.0 acres with a second unit are assessed 0.3 benefit units for the second unit in addition to the assessment for the first unit.
- Vacant parcels less than or equal 2.0 acres – If a parcel is provided sewer service, the parcel was identified to be capable of having a secondary unit potential, but the benefit unit was not increased for this potential. If parcel is on septic, parcel is unable to have a secondary dwelling unit.
- Vacant parcels greater than 2.0 acres – Parcels greater than 2 acres were assessed for a secondary unit if allowed by its land use category.

Group 3: Residential with Three or More Units

This group includes all residential properties, including Land Use Categories Residential Single Family, Residential Rural, Residential Suburban, and Rural Lands with three or more units. This does not include apartments, condominiums, multi-plex, mobile homes or sub-dividable parcels. The following parameters were used to determine benefit unit assignments:

- The first unit is assessed per Group 1.
- The second unit is assessed per Group 2.
- Developed parcels with 3 or more units – Parcels of all size will be assessed 0.7 benefit units each additional unit beyond two units.
- Developed parcels greater than 2.0 acres – If a parcel is greater than 2.0 acres and is sub-dividable, the parcel is assessed for full development potential per Group 1 and Group 2.

Zone A
Basis of Assessment

Group	Sub Group	Land Use Category	Description	Parcel Sizes Included (acres)	Basis of Assessment
1	A	Residential with 1 unit (RSF, RMF, RR, RS, RL)	All residential parcels with one unit	<= to 0.35	1.00 Equivalent Benefit Unit
	B			>0.35 & <= 0.65	1.60 benefit units
	C			>0.65	2.00 benefit units
2	A	Residential with 2 units	Second Unit on a residential property	<=1.00	0.00 benefit units
	B			>1.00	0.30 benefit unit for second unit
3	A	Residential with 3 or More units	Residential properties with greater than two units (Does not include subdividable RSF parcels)	All Parcel Sizes	0.70 benefit unit for each additional unit beyond two units
4	A	Residential Multi-Family (RMF)	Multi-family units w/ no land (i.e. condos, apartments, mobile homes)	All Parcel Sizes	0.70 benefit units per unit
5	A	Commercial (CS, OP, CR)	Commercial Services, Office Professional, Commercial Retail	<= to 0.35	1.00 benefit unit
	B			>0.35 & <= 0.65	1.60 benefit units
	C			>0.65 & <= 2.00	3.00 benefit units
	D			>2.00	6.00 benefit units
6	A	Mini Storage	Storage units with physical storage structures	All Parcel Sizes	0.50 benefit units
7	A	School	School	<= to 0.35	1.00 benefit unit
	B			>0.35 & <= 0.65	1.60 benefit units
	C			>0.65 & <= 2.00	3.00 benefit units
	D			>2.00	3.00 benefit units plus 1.0 benefit unit for every acre above 2.0 acres
8	A	Public Mtg	Includes churches, public meeting halls, excluding schools	<= to 0.35	1.00 benefit unit
	B			>0.35 & <= 0.65	1.60 benefit units
	C			>0.65 & <= 2.00	2.00 benefit units
	D			>2.00	1.00 benefit units per acre
9	A	Recreational	Parks, Fields, etc	All Parcel Sizes	1.00 benefit units per acre
10	A	Government	Government (i.e. Fire Station, Police, etc)	<= to 0.35	1.00 benefit unit
	B			>0.35 & <= 0.65	1.60 benefit units
	C			>0.65 & <= 2.00	3.00 benefit units
	D			>2.00	3.00 benefit units plus 1.00 benefit unit for every acre above 2.00 acres
11	A	Public Facilities w/ No Irrigation	Public Facilities with no irrigation (i.e. wells, tanks, lift stations)	All Parcel Sizes	0.00 benefit units
12	A	Public Facilities w/ Irrigation	Public Facilities with irrigation	All Parcel Sizes	1.00 benefit units per acre
13	A	Open Space w/ No Irrigation	Open Space w/ no irrigation (i.e. medians, parking lots, etc)	All Parcel Sizes	0.00 benefit units
14	A	Open Space w/ Irrigation	Open Space w/ existing irrigation	All Parcel Sizes	1.00 benefit units per acre
15	A	WWTP	Wastewater Treatment Plant	All Parcel Sizes	1.00 benefit unit
16	A	Agriculture	Agriculture parcels using NCSD water	All Parcel Sizes	1.00 benefit units per acre
17	A	Hotel	Hotel or Bed & Breakfast	All Parcel Sizes	0.40 benefit units per room
18	A	Exempted Parcels	Parcels with their own water source	All Parcel Sizes	0.00 benefit units

Group 4: Residential Multi-Family

This group includes all residential multi-family properties with no attributable land (less than 6,000 sq ft lot size), designated as condominiums, apartments, multi-plex, or mobile homes. The following parameters were used to determine benefit unit assignments:

- Each unit is assessed 0.7 benefit units.
- Developed parcels less than or equal 2.0 acres - Parcels were only assessed for their existing use and were not assessed for their full development potential.
- Developed parcels greater than 2.0 acres – Parcels were assessed for their existing development in addition to the parcels full development potential.
- Vacant parcels (any size) – Vacant parcels were assessed for their full development potential.

Group 5: Commercial

This group includes all commercial properties, including Land Use Categories Commercial Services, Office Professional, and Commercial Retail. The following parameters were used to determine benefit unit assignments:

- Developed parcels less than or equal 2.0 acres – Parcels were only assessed for their existing use and were not assessed for their full development potential.
- Developed parcels greater than 2.0 acres – Parcels were assessed for their existing development in addition to the parcels full development potential.
- Vacant parcels (any size) – Vacant parcels were assessed for their full development potential. Full development potential for commercial zoned parcels that allow for residential multi-family development were assessed according to Group 4.

Group 6: Mini Storage

This group includes all parcels identified by their land use as a mini storage. All mini storage parcels are assigned 0.5 benefit units.

Group 7: School

This group includes all parcels identified by their land use as a school. Benefit unit assignments are based on parcel size.

Group 8: Public Meeting

This group includes all parcels that have facilities for public meetings, including churches and public meeting halls, but excluding schools (See Group 7). Benefit unit assignments are based on parcel size.

Group 9: Recreational

This group includes all recreational facilities that are irrigated and/or have public use facilities. Benefit unit assignments are based on parcel size.

Group 10: Government

This group includes all public facilities, including the Fire Station, Police Station, District Office, etc., that use water for inside use and/or outside irrigation. Benefit unit assignments are based on parcel size.

Group 11: Public Facilities with No Irrigation

This group includes all public facilities that do not use water on-site. These parcels include private or public well sites, tank sites, and lift stations. All parcels within this group are assigned zero benefit units.

Group 12: Public Facilities with Irrigation

This group includes all public facilities that do use water on-site. Benefit unit assignment is based on parcel size.

Group 13: Open Space with No Irrigation

This group includes all designated open space parcels with no irrigation. These parcels include hardscaped medians, parking lots, areas with dense oak trees, etc. All parcels within this group are assigned zero benefit units.

Group 14: Open Space with Irrigation

This group includes all designated open space parcels with irrigation. Benefit unit assignment is based on parcel size.

Group 15: Wastewater Treatment Plant

This group includes all public facilities designated for a wastewater treatment plant. These parcels are assigned 1.0 benefit unit regardless of parcel size.

Group 16: Agriculture

This group includes all agriculture parcels that are currently served by Nipomo Community Services District within Zone A. Benefit unit assignment is based on parcel size.

Group 17: Hotel

This group includes all parcels designated for a hotel or bed & breakfast. Benefit unit assignment is based on the number of rooms within the hotel or bed & breakfast.

Group 18: Exempted Parcels

Parcels located within Zone A, but have their own well and underlying appropriative water rights are assigned zero benefit units.

Based on this analysis, there are **5,962.87** benefit units assigned to existing development and **931.41** benefit units assigned to future development (un-developed).

Zone B

The Basis of Assessment for Zone B is summarized in "Zone B Basis of Assessment" table. A full description of each group in this table is as follows:

Zone B
Basis of Assessment

Group	Sub Group	Land Use Category	Description	Parcel Sizes Included (acres)	Basis of Assessment
1	A	Residential with 1 unit (RSF, RMF, RR, RS, RL)	All residential parcels with one unit	</= to 0.35	1.00 Equivalent Benefit Unit
	B			>0.35 & </= 0.65	1.60 benefit units
	C			>0.65	2.00 benefit units
2	A	Residential with 2 units	Second Unit on a residential property	</=1.00	0.00 benefit units
	B			>1.00	0.30 benefit unit for second unit
3	A	Residential with 3 or More units	Residential properties with greater than two units (Does not include subdividable RSF parcels)	All Parcel Sizes	0.70 benefit unit for each additional unit beyond two units
4	A	Residential Multi-Family (RMF)	Multi-family units w/ no land (i.e. condos, apartments, mobile homes)	All Parcel Sizes	0.70 benefit units per unit
5	A	Commercial (CS, OP, CR)	Commercial Services, Office Professional, Commercial Retail	</= to 0.35	1.00 benefit unit
	B			>0.35 & </= 0.65	1.60 benefit units
	C			>0.65 & </= 2.00	3.00 benefit units
	D			>2.00	6.00 benefit units
6	A	Agriculture	Agriculture parcels using GSWC water	All Parcel Sizes	1.00 benefit units per acre
7	A	School	School	</= to 0.35	1.00 benefit unit
	B			>0.35 & </= 0.65	1.60 benefit units
	C			>0.65 & </= 2.00	3.00 benefit units
	D			>2.00	3.00 benefit units plus 1.00 benefit unit for every acre above 2.00 acres
8	A	Government	Government (i.e. Fire Station, Police, etc)	</= to 0.35	1.00 benefit unit
	B			>0.35 & </= 0.65	1.60 benefit units
	C			>0.65 & </= 2.00	3.00 benefit units
	D			>2.00	3.00 benefit units plus 1.00 benefit unit for every acre above 2.00 acres
9	A	Public Facilities w/ No Irrigation	Public Facilities with no irrigation (i.e. wells, tanks, lift stations)	All Parcel Sizes	0.00 benefit units
10	A	Open Space w/ No Irrigation	Open Space w/ no irrigation (i.e. medians, parking lots, etc)	All Parcel Sizes	0.00 benefit units
11	A	Open Space w/ Irrigation	Open Space w/ existing irrigation	All Parcel Sizes	1.00 benefit units per acre
12	A	Exempted Parcels	Parcels with their own water source	All Parcel Sizes	0.00 benefit units

Group 1: Residential with One Unit

This group includes all residential properties, including Land Use Categories Residential Single Family, Residential Multi-Family, Residential Rural, Residential Suburban, and Rural Lands with only one unit. The following parameters were used to determine benefit unit assignments:

- Developed parcels less than or equal 2.0 acres – Parcels were only assessed for their existing use and were not assessed for their full development potential if capable of subdividing or adding an additional granny unit.
- Developed parcels greater than 2.0 acres – Parcels were assessed for their existing development in addition to the parcels full development potential.
- Vacant parcels (any size) – Vacant parcels were assessed for their full development potential.

Group 2: Residential with Two Units

This group includes all residential properties, including Land Use Categories Residential Single Family, Residential Rural, Residential Suburban, and Rural Lands with a second unit. The following parameters were used to determine benefit unit assignments:

- The first unit is assessed per Group 1.
- Developed parcels with 2 units – Parcels less than or equal to 1.0 acre with a second unit are not assessed for the secondary unit. Parcels greater than 1.0 acres with a second unit are assessed 0.3 benefit units for the second unit in addition to the assessment for the first unit.
- Vacant parcels less than or equal 2.0 acres – If a parcel is provided sewer service, the parcel was identified to be capable of having a secondary unit potential, but the benefit unit was not increased for this potential. If parcel is on septic, parcel is unable to have a secondary dwelling unit.
- Vacant parcels greater than 2.0 acres – Parcels greater than 2 acres were assessed for a secondary unit if allowed by its land use category.

Group 3: Residential with Three or More Units

This group includes all residential properties, including Land Use Categories Residential Single Family, Residential Rural, Residential Suburban, and Rural Lands with three or more units. This does not include apartments, condominiums, multi-plex, mobile homes or sub-dividable parcels. The following parameters were used to determine benefit unit assignments:

- The first unit is assessed per Group 1.
- The second unit is assessed per Group 2.
- Developed parcels with 3 or more units – Parcels of all size will be assessed 0.7 benefit units each additional unit beyond two units.
- Developed parcels greater than 2.0 acres – If a parcel is greater than 2.0 acres and is sub-dividable, the parcel is assessed for full development potential per Group 1 and Group 2.

Group 4: Residential Multi-Family

This group includes all residential multi-family properties with no attributable land (less than 6,000 sq ft lot size), designated as condominiums, apartments, multi-plex, or mobile homes. The following parameters were used to determine benefit unit assignments:

- Each unit is assessed 0.7 benefit units.
- Developed parcels less than or equal 2.0 acres - Parcels were only assessed for their existing use and were not assessed for their full development potential.
- Developed parcels greater than 2.0 acres – Parcels were assessed for their existing development in addition to the parcels full development potential.
- Vacant parcels (any size) – Vacant parcels were assessed for their full development potential.

Group 5: Commercial

This group includes all commercial properties, including Land Use Categories Commercial Services, Office Professional, and Commercial Retail. The following parameters were used to determine benefit unit assignments:

- Developed parcels less than or equal 2.0 acres – Parcels were only assessed for their existing use and were not assessed for their full development potential.
- Developed parcels greater than 2.0 acres – Parcels were assessed for their existing development in addition to the parcels full development potential.
- Vacant parcels (any size) – Vacant parcels were assessed for their full development potential. Full development potential for commercial zoned parcels that allow for residential multi-family development were assessed according to Group 4.

Group 6: Agriculture

This group includes all agriculture parcels that are currently served by Golden State Water Company within Zone B. Benefit unit assignment is based on parcel size.

Group 7: School

This group includes all parcels identified by their land use as a school. Benefit unit assignments are based on parcel size.

Group 8: Government

This group includes all public facilities, including the Fire Station, Police Station, District Office, etc., that use water for inside use or outside irrigation. Benefit unit assignments are based on parcel size.

Group 9: Public Facilities with No Irrigation

This group includes all public facilities that do not use water on-site. These parcels include private or public well sites, tank sites, and lift stations. All parcels within this group are assigned zero benefit units.

Group 10: Open Space with No Irrigation

This group includes all designated open space parcels with no irrigation. These parcels include hardscaped medians, parking lots, areas with dense oak trees, etc. All parcels within this group are assigned zero benefit units.

Group 11: Open Space with Irrigation

This group includes all designated open space parcels with irrigation. Benefit unit assignments are based on parcel size.

Group 12: Exempted Parcels

Parcels located within Zone B, but have their own well and underlying appropriative water rights are assigned zero benefit units.

Based on this analysis, there are 2,364.6 benefit units assigned to existing development and 125.25 benefit units assigned to future development (un-developed).

Zone C

The Basis of Assessment for Zone C summarized in “Zone C Basis of Assessment” table. A full description of each group in this table is as follows:

Group 1: Residential with One Unit

This group includes all residential properties, including Land Use Categories Residential Single Family, Residential Multi-Family, Residential Rural, Residential Suburban, and Rural Lands with only one unit. The following parameters were used to determine benefit unit assignments:

- Developed parcels less than or equal 2.0 acres – Parcels were only assessed for their existing use and were not assessed for their full development potential if capable of subdividing or adding an additional granny unit.
- Developed parcels greater than 2.0 acres – Parcels were assessed for their existing development in addition to the parcels full development potential.
- Vacant parcels (any size) – Vacant parcels were assessed for their full development potential.

Group 2: Residential with Two Units

This group includes all residential properties, including Land Use Categories Residential Single Family, Residential Rural, Residential Suburban, and Rural Lands with a second unit. The following parameters were used to determine benefit unit assignments:

- The first unit is assessed per Group 1.
- Developed parcels with 2 units – Parcels less than or equal to 1.0 acre with a second unit are not assessed for the secondary unit. Parcels greater than 1.0 acres with a second unit are assessed 0.3 benefit units for the second unit in addition to the assessment for the first unit.
- Vacant parcels less than or equal 2.0 acres – If a parcel is provided sewer service, the parcel was identified to be capable of having a secondary unit potential, but the benefit unit was not increased for this potential. If parcel is on septic, parcel is unable to have a secondary dwelling unit.
- Vacant parcels greater than 2.0 acres – Parcels greater than 2 acres were assessed for a secondary unit if allowed by its land use category.

Zone C
Basis of Assessment

Group	Sub Group	Land Use Category	Description	Parcel Sizes Included (acres)	Basis of Assessment	
1	A	Residential with 1 unit (RSF, RMF, RR, RS, RL)	All residential parcels with one unit	<= to 0.35	1.00 Equivalent Benefit Unit	
	B					1.60 benefit units
	C					2.00 benefit units
2	A	Residential with 2 units	Second Unit on a residential property	<=1.00	0.00 benefit units	
	B					0.30 benefit unit for second unit
3	A	Commercial (CS, OP, CR)	Commercial Services, Office Professional, Commercial Retail	<= to 0.35	1.0 benefit unit	
	B					1.60 benefit units
	C					3.00 benefit units
	D					6.00 benefit units
4	A	Hotel	Hotel or Bed & Breakfast	All Parcel Sizes	0.40 benefit units per room	
	B					1.00 benefit unit
5	A	School	School	<= to 0.35	1.60 benefit units	
	B					1.60 benefit units
	C					3.00 benefit units
	D					3.00 benefit units plus 1.0 benefit unit for every acre above 2.0 acres
6	A	Recreational	Parks, Fields, etc	All Parcel Sizes	1.00 benefit units per acre	
7	A	Public Facilities w/ No Irrigation	Public Facilities with no irrigation (i.e. wells, tanks, lift stations)	All Parcel Sizes	0.00 benefit units	
	A					1.00 benefit units per acre
8	A	Public Facilities w/ Irrigation	Public Facilities with irrigation	All Parcel Sizes	1.00 benefit units per acre	
9	A	Open Space w/ No Irrigation	Open Space w/ no irrigation (i.e. medians, parking lots, etc)	All Parcel Sizes	0.00 benefit units	
10	A	Open Space w/ Irrigation	Open Space w/ existing irrigation	All Parcel Sizes	1.00 benefit units per acre	
11	A	WWTP	Wastewater Treatment Plant	All Parcel Sizes	1.00 benefit unit	
12	A	Exempted Parces	Parcels with their own water source	All Parcel Sizes	0.00 benefit units	
13	A	Agriculture	Agriculture parcels using RWC water	All Parcel Sizes	1.00 benefit units per acre	

Group 3: Commercial

This group includes all commercial properties, including Land Use Categories Commercial Services, Office Professional, and Commercial Retail. The following parameters were used to determine benefit unit assignments:

- Developed parcels less than or equal 2.0 acres – Parcels were only assessed for their existing use and were not assessed for their full development potential.
- Developed parcels greater than 2.0 acres – Parcels were assessed for their existing development in addition to the parcels full development potential.
- Vacant parcels (any size) – Vacant parcels were assessed for their full development potential. Full development potential for commercial zoned parcels that allow for residential multi-family development were assessed according to Zone A Group 4.

Group 4: Hotel

This group includes all parcels designated for a hotel or bed & breakfast. Benefit unit assignment is based on the number of rooms within the hotel or bed & breakfast.

Group 5: School

This group includes all parcels identified by their land use as a school. Benefit unit assignments are based on parcel size.

Group 6: Recreational

This group includes all recreational facilities that are irrigated and/or have public facilities. Benefit unit assignments are based on parcel size.

Group 7: Public Facilities with No Irrigation

This group includes all public facilities that do not use water on-site. These parcels include private or public well sites, tank sites, and lift stations. All parcels within this group are assigned zero benefit units.

Group 8: Public Facilities with Irrigation

This group includes all public facilities that do use water on-site. Benefit unit assignments are based on parcel size.

Group 9: Open Space with No Irrigation

This group includes all designated open space parcels with no irrigation. These parcels include hardscaped medians, parking lots, areas with dense oak trees, etc. All parcels within this group are assigned zero benefit units.

Group 10: Open Space with Irrigation

This group includes all designated open space parcels with irrigation. Benefit unit assignments are based on parcel size.

Group 11: Wastewater Treatment Plant

This group includes all public facilities designated for a wastewater treatment plant. These parcels are assigned 1.0 benefit unit regardless of parcel size.

Group 12: Exempted Parcels

Parcels located within Zone C, but have their own well and underlying appropriative water rights are assigned zero benefit units.

Based on this analysis, there are 1,412.1 benefit units assigned to existing development and 145.41 benefit units assigned to future development (un-developed).

Zone D

The Basis of Assessment for Zone D is summarized in "Zone D Basis of Assessment" table. A full description of each group in this table is as follows:

Group 1: Residential with One Unit

This group includes all residential properties with only one unit. The following parameters were used to determine benefit unit assignments:

- Developed Parcels – All developed residential parcels were assessed 1.0 benefit unit.
- Subdivided Vacant Parcels – Vacant parcels that are already subdivided in to individual lots were assessed 1.0 benefit unit.
- Un-Subdivided Vacant Parcels – Vacant parcels that have not been subdivided were assessed based on the number of residential parcels identified in the approved tentative map for the Woodlands subdivision.

Group 2: Residential Multi-Family

This group includes all residential multi-family properties with no attributable land (less than 6,000 sq. ft.), designated as condominiums or apartments. Each unit is assessed 0.7 benefit units.

Group 3: Commercial

This group includes all commercial properties, including Land Use Categories Commercial Services, Office Professional, and Commercial Retail. Commercial parcels were assessed based on parcel size. For mixed use on commercial, the one-bedroom unit above commercial is assessed 0.50 per unit in addition to the commercial benefit unit assignment.

Group 4: Open Space

This group includes all designated open space parcels, including open space, golf course, buffer lots, and Park & Ride facility. All parcels within this group are assigned zero benefit units.

Group 5: Public Facilities

This group includes all designated public facilities, including tank site, wells, lift station, maintenance yard, and wastewater treatment plant. All parcels within this group are assigned zero benefit units.

Group 6: Resort

This group includes all parcels designated for a resort or assisted living facility. Benefit unit assignment is based on the number of rooms within the resort.

Zone D
Basis of Assessment

Group	Sub Group	Land Use Category	Description	Parcel Sizes Included (acres)	Basis of Assessment
1	A	Residential (RSF)	All residential parcels with one unit	All Parcel Sizes	1.00 Equivalent Benefit Unit
2	A	Residential Multi-Family (RMF)	Multi-family units	<0.10	0.70 benefit units per unit
3	A	Commercial (CS, OP, CR)	Commercial Services, Office Professional, Commercial Retail	<=1.20	1.50 benefit units
	B			>1.20 & <=3.50	3.00 benefit units
	C			>3.50	6.00 benefit units
	D			All Parcel Sizes	0.50 benefit units per unit (in addition to Com)
4	A	Open Space	Open Space, Golf Course, Buffer Lots, Park & Ride	All Parcel Sizes	0.00 benefit units
5	A	Public Facilities	All Public Facilities	All Parcel Sizes	0.00 benefit units
	A			Resort	All Parcel Sizes
6	A	Resort	Assisted Living	All Parcel Sizes	0.35 benefit units per room
	B			>8.00	90.0 benefit units
7	A	Trilogy Center	Monarch Club (Trilogy Center)	All Parcel Sizes	5.00 benefit units
8	A	Golf Course Facilities	Golf Club and Maintenance Facility	All Parcel Sizes	5.00 benefit units

Group 7: Trilogy Center

This group includes the parcel designated for the Trilogy Center (Monarch Club). Benefit unit assignment will be 90.0 benefit units.

Group 8: Golf Course Facilities

This group includes the club house and the maintenance facility for the golf course. Each facility is assigned 5.0 benefit units.

Based on this analysis, there are 700.7 benefit units assigned to existing development and 847.05 benefit units assigned to future development (un-developed).

Summary

Based on the above methodology the total benefit units assigned to each Zone is as follows:

	Total # of Benefit Units	Developed Benefit Units	Undeveloped Benefit Units
Zone A	5,894.28	5,962.87	931.41
Zone B	2,677.73	2,364.6	125.25
Zone C	1,557.51	1,412.10	145.41
Zone D	1,547.75	700.70	847.05

B. ASSESSMENT RATE CALCULATION

Zone A

Zone A is comprised on residential and commercial units on varying parcel sizes. It also includes the planned development known as Black Lake. Based on the basis of assessment, Zone A has a total of **6,894.28** benefit units. Zone A's share of the project is **\$19,186,314**. The Nipomo Community Services District is allocating \$6,000,000 from reserves to reduce the assessment on developed properties within Zone A, thus the total assessment cost for Zone A is **\$13,186,314**. The cost per benefit unit is **\$2,782.93**.

Nipomo Community Services District has authorized to use of \$6,000,000 of NCSD funds to reduce the cost of the project for the developed parcels within Zone A. Based on this reduction the following provides a summary of the cost per benefit unit for developed and undeveloped parcels:

Project Cost	\$19,186,314
Total # of Benefit Units	6,894.28
Cost Per Benefit Unit	\$2,782.93
<hr/>	
Total # of Developed Benefit Units	5,962.87
Total Project Cost Attributed to Developed Benefit Units	\$16,594,263.09
Less District Funds (\$6,000,000)	\$10,594,263.09
Revised Cost Per Benefit Unit for Developed Parcels Only	\$1,776.71

The cost per benefit unit for undeveloped parcels is \$2,782.93. The cost per benefit unit for developed parcels is \$1,776.71.

Zone B

Zone B is comprised of large residential units on septic systems. Based on basis of assessment, Zone B has a total of 2,489.85 benefit units. Zone B's share of the project is \$2,086,047. The cost per benefit unit is \$837.82.

Zone C

Zone C is comprised of large residential units and the planned development known as Cypress Ridge. Based on the basis of assessment, Zone C has a total of 1,557.51 benefit units. Zone C's share of the project is \$2,086,047. The cost per benefit unit is \$1,339.35.

Zone D

Woodlands Mutual Water Company owns and operates the water and sewer facilities within the planned community known as the Woodlands. The Woodlands is not fully built out. The Woodlands has an approved tentative map allowing for 1,320 residential units, plus additional commercial facilities. Based on basis of assessment, Zone D has a total of 1,547.75 benefit units. Zone D's share of the project is \$4,104,906. The cost per benefit unit is \$2,652.18.

PART VI

ASSESSMENT AND ASSESSMENT ROLL

The assessments are hereby made upon the parcels of land within the Assessment District and the Zones therein in proportion to the estimated special benefits to be received by said parcels, respectively, from said improvement. The Diagram and assessment numbers appearing herein are the diagram numbers appearing on the Diagram, to which reference is hereby made for a more particular description of said property.

A list of names and addresses of the owners of all parcels, and the description of each lot or parcel within each Zone of the Assessment District is shown on the last equalized Property Tax Roll of the San Luis Obispo County Assessor, which by reference is hereby made part of this report.

This list is keyed to the Assessor's Parcel Numbers as shown on the Assessment Roll, which includes the proposed amount of assessment apportioned to each lot or parcel and the parcel's assessment number within each Zone of the Assessment District. The Assessment Roll for the Assessment District is shown in a separately bound document which is on file with the Secretary of the Board; said material being too bulky to be bound with this Engineer's Report. The Assessment Roll is incorporated herein as if set forth fully herein.

PART VII

MAXIMUM ANNUAL ADMINISTRATION ASSESSMENT

The Board of Directors intends, pursuant to subparagraph (f) of Section 10204 of the Improvement Act, to authorize an annual assessment upon each of the parcels of land in the proposed Assessment District to pay various costs and expenses incurred from time to time by the Nipomo Community Services District and not otherwise reimbursed to the Nipomo Community Services District, which result from the administration and collection of assessment installments or from the administration or registration of the improvement bonds and the various funds and accounts pertaining thereto, in an amount per year not to exceed **six dollars (\$6) per parcel**, however, said amount may be subject to an **inflation adjustment of up to 2% per year**, based on _____. This annual assessment shall be in addition to any fee **charged pursuant to Section 8682 and 8682.1 of the Streets and Highways Code**.

Environmental Certification Attachments
Right-of-Way Certification Attachments

Nipomo Mesa Supplemental Water Project Assessment District No. 1

Nipomo Community Services District
State of California



Part V

Assessment Diagram

For
Nipomo Community Services District

February 2012 Draft



ASSESSMENT DIAGRAM

NIPOMO MESA
SUPPLEMENTAL
SERVICES DISTRICT
ASSESSMENT DISTRICT
NO.1

NIPOMO COMMUNITY
SERVICES DISTRICT
STATE OF CALIFORNIA

Legend

-  ASSESSMENT BOUNDARY
-  ASSESSOR PARCEL
-  DIAGRAM SHEET



1 inch = 3,200 Feet
0 1,600 3,200

SHEET:
1 OF 59

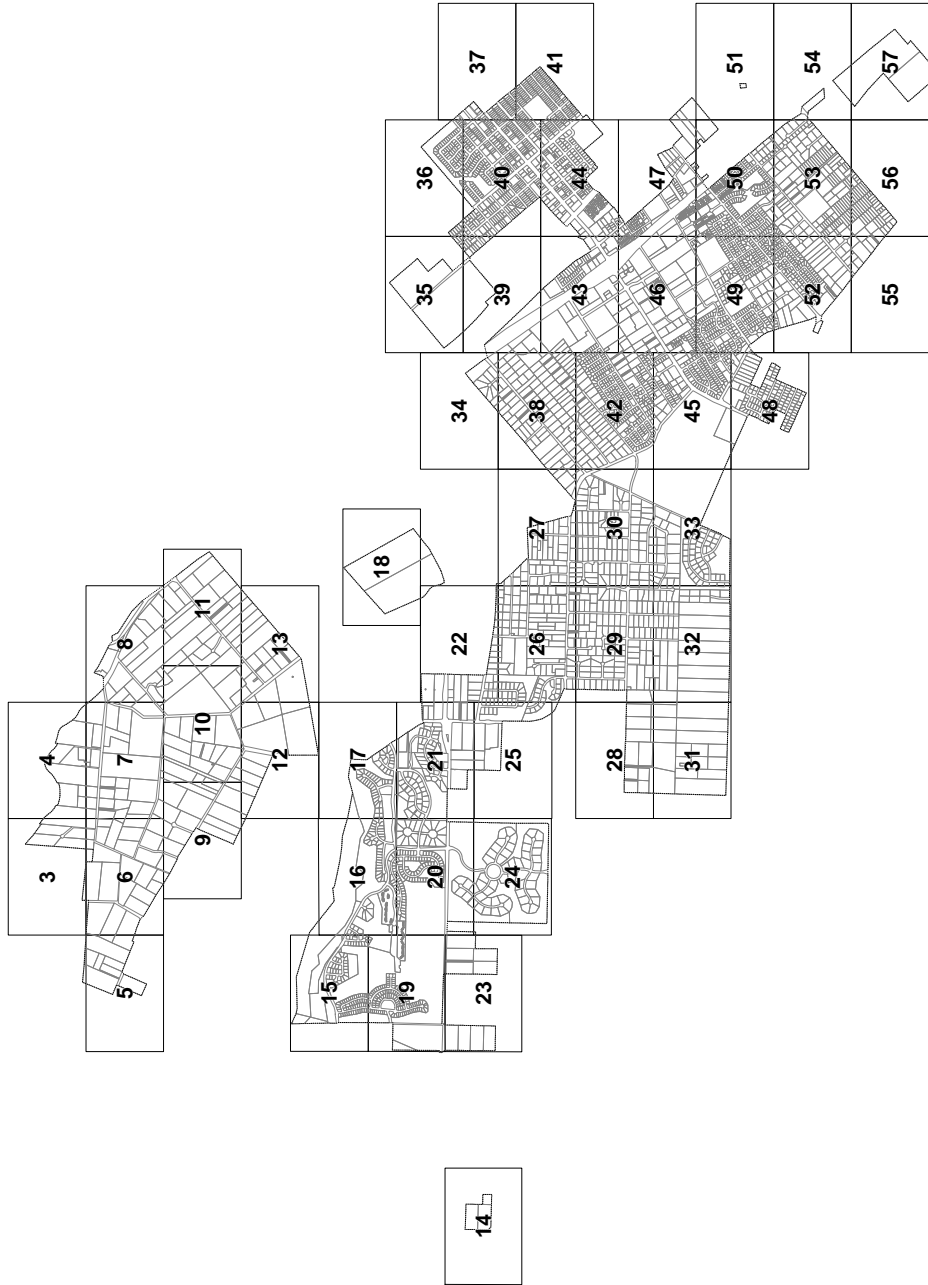

LOTS ON THIS SHEET ARE
EASELMENTS TO THE
MAP COUNTY OF SAN LUIS
OBISPO, CA; BK 080 PGS:
072, 078, 079, 081, 082, 083,
084, 085, 086, 087, 088, 089,
095, 101, 102, 103, 111, 121,
122, 123, 131, 132, 133, 134,
135, 146, 147, 148, 149, 150,
151, 152, 153, 154, 155, 156,
157, 158, 159, 160, 161, 162,
163, 164, 165, 166, 167, 168,
169, 170, 171, 172, 173, 174,
175, 176, 177, 178, 179, 180,
181, 182, 183, 184, 185, 186,
187, 188, 189, 190, 191, 192,
193, 194, 195, 196, 197, 198,
199, 200, 201, 202, 203, 204,
205, 206, 207, 208, 209, 210,
211, 212, 213, 214, 215, 216,
217, 218, 219, 220, 221, 222,
223, 224, 225, 226, 227, 228,
229, 230, 231, 232, 233, 234,
235, 236, 237, 238, 239, 240,
241, 242, 243, 244, 245, 246,
247, 248, 249, 250, 251, 252,
253, 254, 255, 256, 257, 258,
259, 260, 261, 262, 263, 264,
265, 266, 267, 268, 269, 270,
271, 272, 273, 274, 275, 276,
277, 278, 279, 280, 281, 282,
283, 284, 285, 286, 287, 288,
289, 290, 291, 292, 293, 294,
295, 296, 297, 298, 299, 300,
301, 302, 303, 304, 305, 306,
307, 308, 309, 310, 311, 312,
313, 314, 315, 316, 317, 318,
319, 320, 321, 322, 323, 324,
325, 326, 327, 328, 329, 330,
331, 332, 333, 334, 335, 336,
337, 338, 339, 340, 341, 342,
343, 344, 345, 346, 347, 348,
349, 350, 351, 352, 353, 354,
355, 356, 357, 358, 359, 360,
361, 362, 363, 364, 365, 366,
367, 368, 369, 370, 371, 372,
373, 374, 375, 376, 377, 378,
379, 380, 381, 382, 383, 384,
385, 386, 387, 388, 389, 390,
391, 392, 393, 394, 395, 396,
397, 398, 399, 400, 401, 402,
403, 404, 405, 406, 407, 408,
409, 410, 411, 412, 413,
414, 415, 416, 417, 418, 419,
420, 421, 422, 423, 424, 425,
426, 427, 428, 429, 430, 431,
432, 433, 434, 435, 436, 437,
438, 439, 440, 441, 442,
443, 444, 445, 446, 447, 448,
449, 450, 451, 452, 453, 454,
455, 456, 457, 458, 459, 460,
461, 462, 463, 464, 465, 466,
467, 468, 469, 470, 471, 472,
473, 474, 475, 476, 477, 478,
479, 480, 481, 482, 483, 484,
485, 486, 487, 488, 489, 490,
491, 492, 493, 494, 495, 496,
497, 498, 499, 500, 501, 502,
503, 504, 505, 506, 507, 508,
509, 510, 511, 512, 513, 514,
515, 516, 517, 518, 519, 520,
521, 522, 523, 524, 525, 526,
527, 528, 529, 530, 531, 532,
533, 534, 535, 536, 537, 538,
539, 540, 541, 542, 543, 544,
545, 546, 547, 548, 549, 550,
551, 552, 553, 554, 555, 556,
557, 558, 559, 560, 561, 562,
563, 564, 565, 566, 567, 568,
569, 570, 571, 572, 573, 574, 575,
576, 577, 578, 579, 580, 581,
582, 583, 584, 585, 586, 587,
588, 589, 590, 591, 592, 593,
594, 595, 596, 597, 598, 599,
600, 601, 602, 603, 604, 605,
606, 607, 608, 609, 610, 611,
612, 613, 614, 615, 616, 617,
618, 619, 620, 621, 622, 623,
624, 625, 626, 627, 628, 629,
630, 631, 632, 633, 634, 635,
636, 637, 638, 639, 640, 641,
642, 643, 644, 645, 646, 647,
648, 649, 650, 651, 652, 653,
654, 655, 656, 657, 658, 659,
660, 661, 662, 663, 664, 665,
666, 667, 668, 669, 670, 671,
672, 673, 674, 675, 676, 677,
678, 679, 680, 681, 682, 683,
684, 685, 686, 687, 688, 689,
690, 691, 692, 693, 694, 695,
696, 697, 698, 699, 700, 701,
702, 703, 704, 705, 706, 707,
708, 709, 710, 711, 712, 713,
714, 715, 716, 717, 718, 719,
720, 721, 722, 723, 724, 725,
726, 727, 728, 729, 730, 731,
732, 733, 734, 735, 736, 737,
738, 739, 740, 741, 742, 743,
744, 745, 746, 747, 748, 749,
750, 751, 752, 753, 754, 755,
756, 757, 758, 759, 760, 761,
762, 763, 764, 765, 766, 767,
768, 769, 770, 771, 772, 773,
774, 775, 776, 777, 778, 779,
780, 781, 782, 783, 784, 785,
786, 787, 788, 789, 790, 791,
792, 793, 794, 795, 796, 797,
798, 799, 800, 801, 802, 803,
804, 805, 806, 807, 808, 809,
810, 811, 812, 813, 814, 815,
816, 817, 818, 819, 820, 821,
822, 823, 824, 825, 826, 827,
828, 829, 830, 831, 832, 833,
834, 835, 836, 837, 838, 839,
840, 841, 842, 843, 844, 845,
846, 847, 848, 849, 850, 851,
852, 853, 854, 855, 856, 857,
858, 859, 860, 861, 862, 863,
864, 865, 866, 867, 868, 869,
870, 871, 872, 873, 874, 875,
876, 877, 878, 879, 880, 881,
882, 883, 884, 885, 886, 887,
888, 889, 890, 891, 892, 893,
894, 895, 896, 897, 898, 899,
900, 901, 902, 903, 904, 905,
906, 907, 908, 909, 910, 911,
912, 913, 914, 915, 916, 917,
918, 919, 920, 921, 922, 923,
924, 925, 926, 927, 928, 929,
930, 931, 932, 933, 934, 935,
936, 937, 938, 939, 940, 941,
942, 943, 944, 945, 946, 947,
948, 949, 950, 951, 952, 953,
954, 955, 956, 957, 958, 959,
960, 961, 962, 963, 964, 965,
966, 967, 968, 969, 970, 971,
972, 973, 974, 975, 976, 977,
978, 979, 980, 981, 982, 983,
984, 985, 986, 987, 988, 989,
990, 991, 992, 993, 994, 995,
996, 997, 998, 999, 1000

ASSESSMENT NUMBER INDEX

SHEET NUMBER:	ASSESSMENT NUMBER:	SHEET NUMBER:	ASSESSMENT NUMBER:
SHEET 3	0001-0004	SHEET 32	1297-1339
SHEET 4	0005-0011	SHEET 33	1340-1409
SHEET 5	0012-0018	SHEET 34	1410-1419
SHEET 6	0019-0040	SHEET 35	1420-1424
SHEET 7	0041-0062	SHEET 36	1425-1501
SHEET 8	0063-0081	SHEET 37	1502-1547
SHEET 9	0082-0095	SHEET 38	1548-1637
SHEET 10	0096-0115	SHEET 39	1638-1655
SHEET 11	0116-0139	SHEET 40	1656-2014
SHEET 12	0140-0146	SHEET 41	2015-2139
SHEET 13	0147-0163	SHEET 42	2140-2475
SHEET 14	0164-0166	SHEET 43	2476-2552
SHEET 15	0167-0271	SHEET 44	2553-2808
SHEET 16	0272-0371	SHEET 45	2809-2970
SHEET 17	0372-0422	SHEET 46	2971-3101
SHEET 18	0423-0424	SHEET 47	3102-3248
SHEET 19	0425-0569	SHEET 48	3249-3374
SHEET 20	0570-0701	SHEET 49	3375-3730
SHEET 21	0702-0791	SHEET 50	3731-4105
SHEET 22	0792-0821	SHEET 51	4106-4107
SHEET 23	0822-0830	SHEET 52	4108-4294
SHEET 24	0831-0882	SHEET 53	4295-4445
SHEET 25	0883-0895	SHEET 54	4446-4447
SHEET 26	0896-1010	SHEET 55	4448-4453
SHEET 27	1011-1057	SHEET 56	4454-4506
SHEET 28	1058-1066	SHEET 57	4507-4508
SHEET 29	1067-1172	SHEET 58	4509-4539
SHEET 30	1173-1278	SHEET 59	4540-4598
SHEET 31	1279-1296		

**ASSESSMENT
DIAGRAM**

NIPOMO MESA
SUPPLEMENTAL
SERVICES DISTRICT
ASSESSMENT DISTRICT
NO.1

NIPOMO COMMUNITY
SERVICES DISTRICT
STATE OF CALIFORNIA

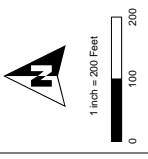
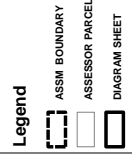

**SHEET:
3 OF 59**





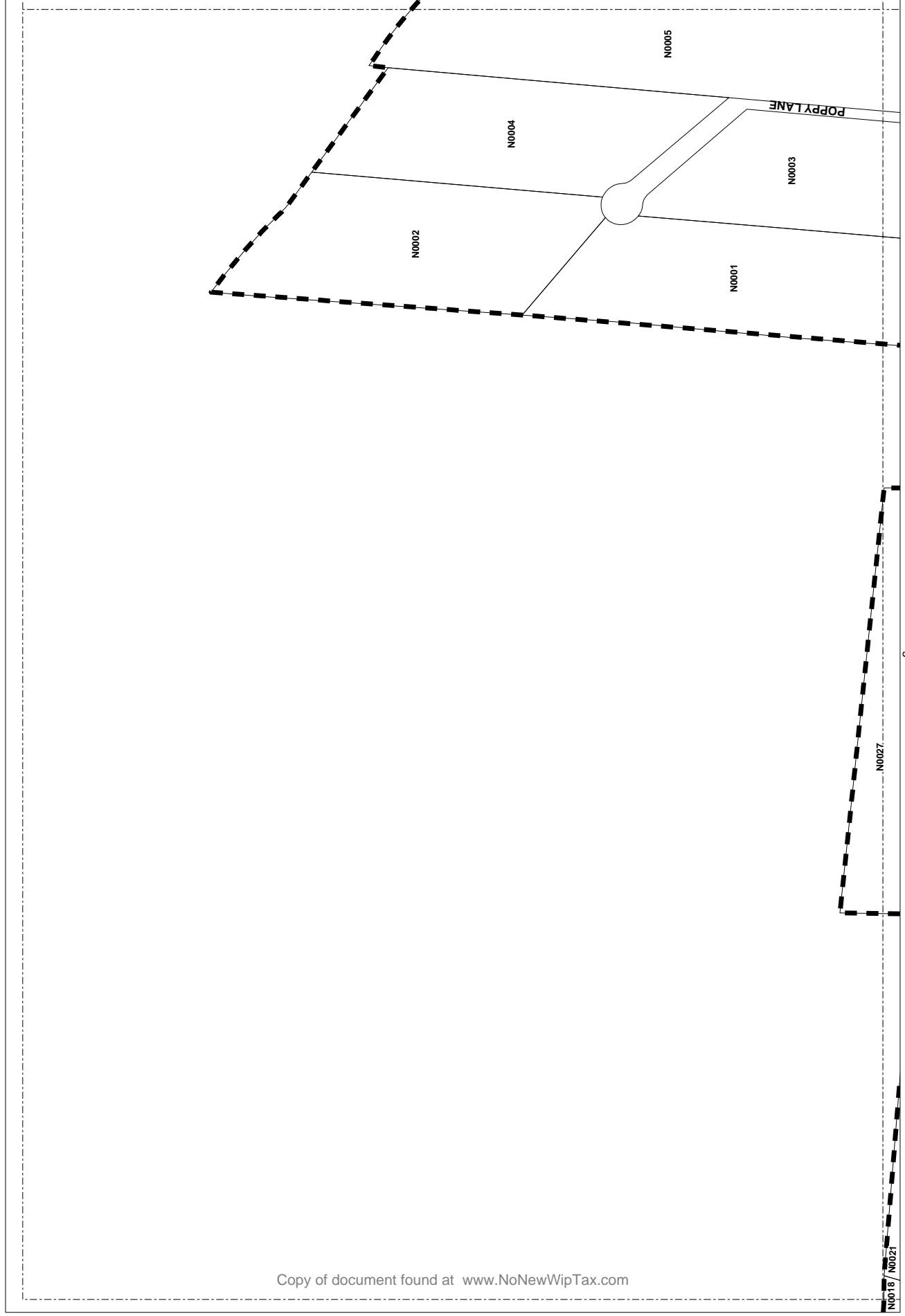

































LOTS ON THIS SHEET ARE
BASED UPON THE 1997
MAP COUNTY OF SAN LUIS
OBISPO, CA; BK 080 PGS:
072, 078, 079, 081, 082, 083,
084, 085, 086, 087, 088, 089,
095, 101, 102, 103, 111, 121,
122, 123, 131, 132, 133, 134,
135, 146, 147, 148, 149, 150,
151, 152, 153, 154, 155, 156,
157, 158, 159, 160, 161, 162,
163, 164, 165, 166, 167, 168,
169, 170, 171, 172, 173, 174,
175, 176, 177, 178, 179, 180,
181, 182, 183, 184, 185, 186,
187, 188, 189, 190, 191, 192,
193, 194, 195, 196, 197, 198,
199, 200, 201, 202, 203, 204,
205, 206, 207, 208, 209, 210,
211, 212, 213, 214, 215, 216,
217, 218, 219, 220, 221, 222,
223, 224, 225, 226, 227, 228,
229, 230, 231, 232, 233, 234,
235, 236, 237, 238, 239, 240,
241, 242, 243, 244, 245, 246,
247, 248, 249, 250, 251, 252,
253, 254, 255, 256, 257, 258,
259, 260, 261, 262, 263, 264,
265, 266, 267, 268, 269, 270,
271, 272, 282, 283, 291, 302,
303, 304, 311, 321, 331, 341,
351, 361, 371, 381, 391, 401,
385, 462, 463, 510, 512, 513,
531, 532, 533, 534, 551, 570,
571, 572, 573, 574, 575, 576,
577.



**ASSESSMENT
DIAGRAM**

NIPOMO MESA
SUPPLEMENTAL
SERVICES DISTRICT
ASSESSMENT DISTRICT
NO.1

NIPOMO COMMUNITY
SERVICES DISTRICT
STATE OF CALIFORNIA

- Legend**
-  ASSESSOR PARCEL
 -  ASSESSOR PARCEL
 -  ASSESSOR PARCEL
 -  ASSESSOR PARCEL
 -  ASSESSOR PARCEL
 -  ASSESSOR PARCEL
 -  ASSESSOR PARCEL
 -  ASSESSOR PARCEL
 -  ASSESSOR PARCEL
 -  ASSESSOR PARCEL
 -  ASSESSOR PARCEL
 -  ASSESSOR PARCEL
 -  ASSESSOR PARCEL
 -  ASSESSOR PARCEL
 -  ASSESSOR PARCEL
 -  ASSESSOR PARCEL
 -  ASSESSOR PARCEL
 -  ASSESSOR PARCEL
 -  ASSESSOR PARCEL
 -  ASSESSOR PARCEL
 -  ASSESSOR PARCEL
 -  ASSESSOR PARCEL
 -  ASSESSOR PARCEL
 -  ASSESSOR PARCEL
 -  ASSESSOR PARCEL
 -  ASSESSOR PARCEL
 -  ASSESSOR PARCEL
 -  ASSESSOR PARCEL
 -  ASSESSOR PARCEL
 -  ASSESSOR PARCEL
 -  ASSESSOR PARCEL
 -  ASSESSOR PARCEL
 -  ASSESSOR PARCEL
 -  ASSESSOR PARCEL
 -  ASSESSOR PARCEL
 -  ASSESSOR PARCEL
 -  ASSESSOR PARCEL

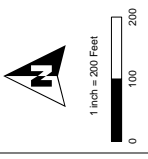

**SHEET:
4 OF 59**

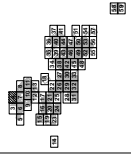

LOTS ON THIS SHEET ARE
ELECTED TO BE REVALUED
BY THE BOARD OF SUPERVISORS
MAP COUNTY OF SAN LUIS
OBISPO, CA; BK 080 PGS:
072, 078, 079, 081, 082, 083,
084, 085, 086, 087, 088, 089,
090, 091, 092, 093, 094, 095,
096, 097, 098, 099, 100, 101,
102, 103, 104, 105, 106, 107,
108, 109, 110, 111, 112, 113,
114, 115, 116, 117, 118, 119,
120, 121, 122, 123, 124, 125,
126, 127, 128, 129, 130, 131,
132, 133, 134, 135, 136, 137,
138, 139, 140, 141, 142, 143,
144, 145, 146, 147, 148, 149,
150, 151, 152, 153, 154, 155,
156, 157, 158, 159, 160, 161,
162, 163, 164, 165, 166, 167,
168, 169, 170, 171, 172, 173,
174, 175, 176, 177, 178, 179,
180, 181, 182, 183, 184, 185,
186, 187, 188, 189, 190, 191,
192, 193, 194, 195, 196, 197,
198, 199, 200, 201, 202, 203,
204, 205, 206, 207, 208, 209,
210, 211, 212, 213, 214, 215,
216, 217, 218, 219, 220, 221,
222, 223, 224, 225, 226, 227,
228, 229, 230, 231, 232, 233,
234, 235, 236, 237, 238, 239,
240, 241, 242, 243, 244, 245,
246, 247, 248, 249, 250, 251,
252, 253, 254, 255, 256, 257,
258, 259, 260, 261, 262, 263,
264, 265, 266, 267, 268, 269,
270, 271, 272, 273, 274, 275,
276, 277, 278, 279, 280, 281,
282, 283, 284, 285, 286, 287,
288, 289, 290, 291, 292, 293,
294, 295, 296, 297, 298, 299,
300, 301, 302, 303, 304, 305,
306, 307, 308, 309, 310, 311,
312, 313, 314, 315, 316, 317,
318, 319, 320, 321, 322, 323,
324, 325, 326, 327, 328, 329,
330, 331, 332, 333, 334, 335,
336, 337, 338, 339, 340, 341,
342, 343, 344, 345, 346, 347,
348, 349, 350, 351, 352, 353,
354, 355, 356, 357, 358, 359,
360, 361, 362, 363, 364, 365,
366, 367, 368, 369, 370, 371,
372, 373, 374, 375, 376, 377,
378, 379, 380, 381, 382, 383,
384, 385, 386, 387, 388, 389,
390, 391, 392, 393, 394, 395,
396, 397, 398, 399, 400, 401,
402, 403, 404, 405, 406, 407,
408, 409, 410, 411, 412, 413,
414, 415, 416, 417, 418, 419,
420, 421, 422, 423, 424, 425,
426, 427, 428, 429, 430, 431,
432, 433, 434, 435, 436, 437,
438, 439, 440, 441, 442, 443,
444, 445, 446, 447, 448, 449,
450, 451, 452, 453, 454, 455,
456, 457, 458, 459, 460, 461,
462, 463, 464, 465, 466, 467,
468, 469, 470, 471, 472, 473,
474, 475, 476, 477, 478, 479,
480, 481, 482, 483, 484, 485,
486, 487, 488, 489, 490, 491,
492, 493, 494, 495, 496, 497,
498, 499, 500, 501, 502, 503,
504, 505, 506, 507, 508, 509,
510, 511, 512, 513, 514, 515,
516, 517, 518, 519, 520, 521,
522, 523, 524, 525, 526, 527,
528, 529, 530, 531, 532, 533,
534, 535, 536, 537, 538, 539,
540, 541, 542, 543, 544, 545,
546, 547, 548, 549, 550, 551,
552, 553, 554, 555, 556, 557,
558, 559, 560, 561, 562, 563,
564, 565, 566, 567, 568, 569,
570, 571, 572, 573, 574, 575, 576,
577, 578, 579, 580, 581, 582,
583, 584, 585, 586, 587, 588,
589, 590, 591, 592, 593, 594,
595, 596, 597, 598, 599, 600.

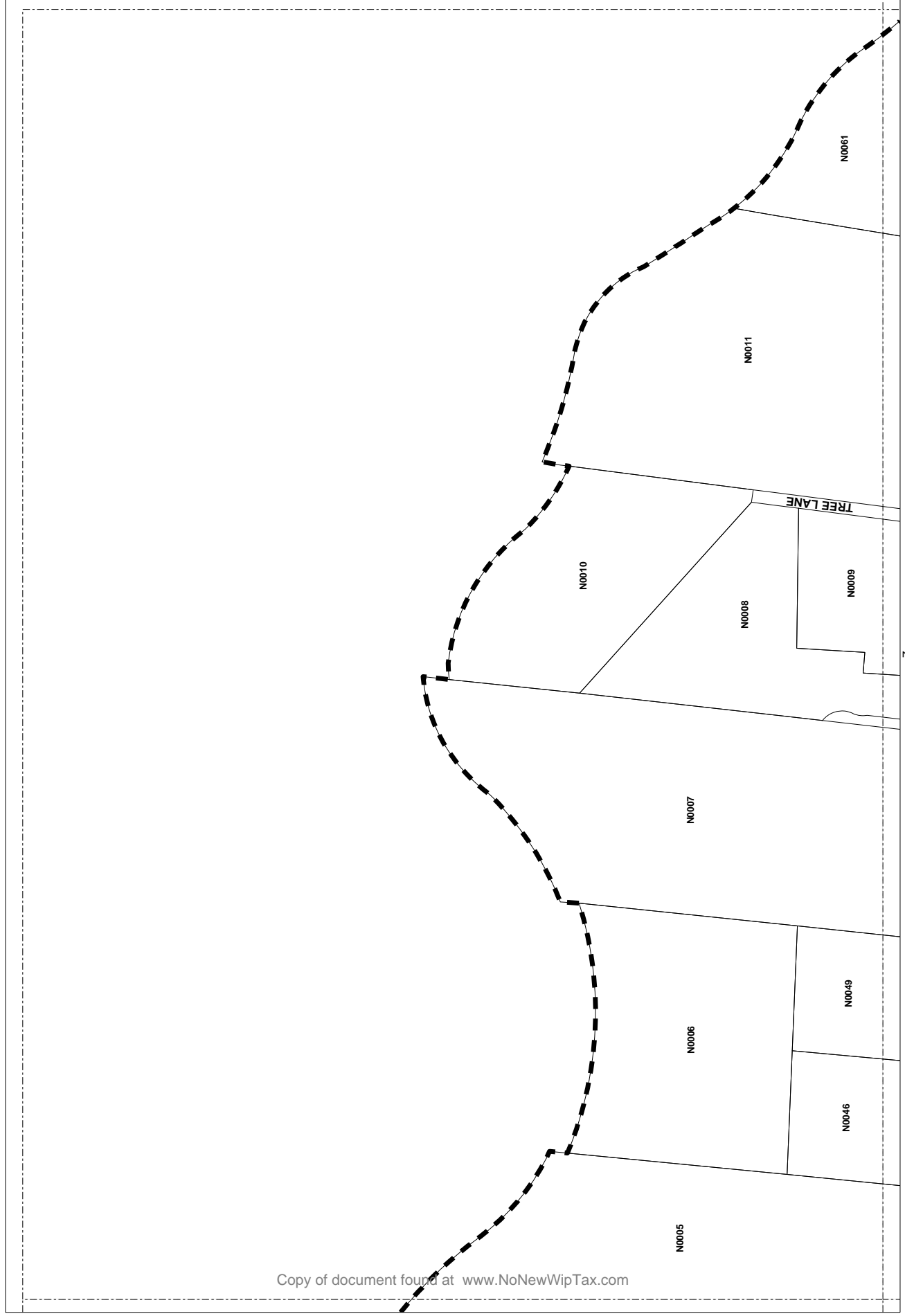





**ASSESSMENT
DIAGRAM**

NIPOMO MESA
SUPPLEMENTAL
SERVICES DISTRICT
ASSESSMENT DISTRICT
NO.1

NIPOMO COMMUNITY
SERVICES DISTRICT
STATE OF CALIFORNIA

Legend

-  ASSESSOR PARCEL
-  ASSESSOR PARCEL
-  DIAGRAM SHEET



1 inch = 200 Feet

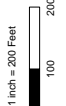

**SHEET:
5 OF 59**

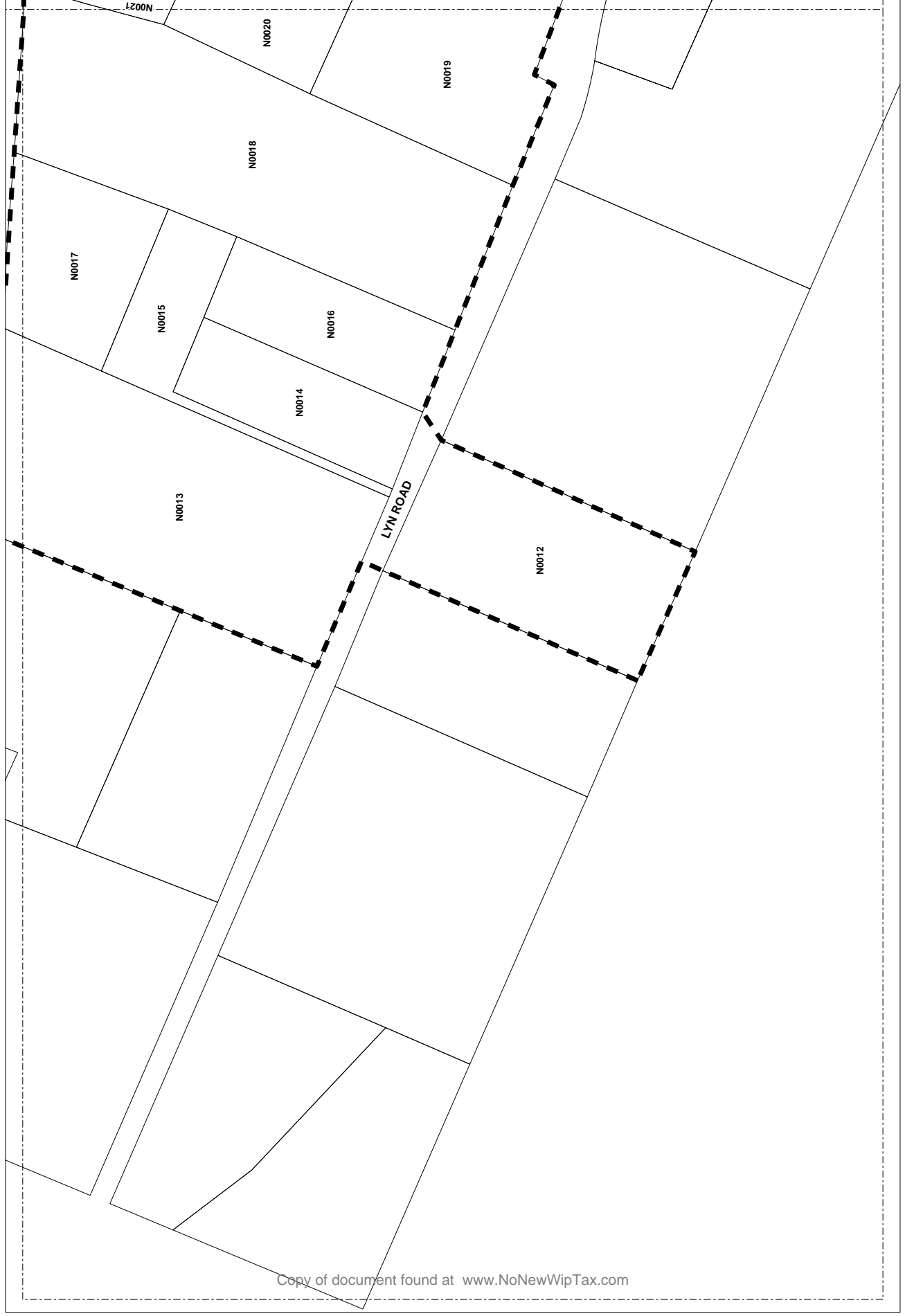
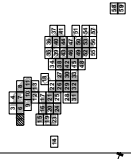





LOTS ON THIS SHEET ARE
INDEXED TO THE MAPS OF
MAP COUNTY OF SAN LUIS
OBISPO, CA; BK 080 PGS:
072, 078, 079, 081, 082, 083,
084, 085, 086, 087, 088,
089, 090, 102, 103, 111, 121,
122, 123, 131, 132, 133, 134,
135, 136, 141, 142, 143, 144,
151, 152, 161, 162, 163, 164,
307, 361, 362, 363, 364, 371,
372, 381, 382, 383, 384, 385,
386, 387, 388, 389, 390, 391,
BK 091 PGS: 011, 053, 054,
063, 073, 081, 081, 121, 131,
202, 233, 243, 244, 246, 247,
248, 249, 250, 251, 252, 253,
257, 311, 313, 320, 325, 326,
327, 328, 371, 372, 373, 374,
375, 376, 381, 382, 410, 411,
412, 413, 414, 415, 416, 417,
421, 430, 431, 440, 441, 442,
443, 444, 445, 446,
BK 092 PGS: 081, 082, 083,
084, 085, 086, 087, 088, 089,
120, 130, 136, 137, 138, 139,
141, 142, 143, 144, 145, 146,
147, 148, 149, 150, 152, 153,
154, 155, 156, 157, 158, 159,
281, 281, 282, 281, 282, 283,
271, 272, 282, 283, 281, 302,
303, 304, 311, 321, 331, 341,
351, 361, 371, 381, 391, 401,
385, 462, 463, 510, 512, 513,
531, 532, 533, 534, 551, 570,
571, 572, 573, 574, 575, 576,
577.

**ASSESSMENT
DIAGRAM**

NIPOMO MESA
SUPPLEMENTAL
REVENUE DISTRICT
ASSESSMENT DISTRICT
NO.1

NIPOMO COMMUNITY
SERVICES DISTRICT
STATE OF CALIFORNIA

Legend

-  ASSESSOR PARCEL
-  ASSESSOR PARCEL
-  ASSESSOR PARCEL
-  DIAGRAM SHEET



1 inch = 200 Feet

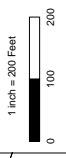

**SHEET:
6 OF 59**



LOTS ON THIS SHEET ARE
BASED ON THE 1997
MAP COUNTY OF SAN LUIS
OBISPO, CA; BK 080 PGS:
072, 078, 079, 081, 082, 083,
084, 085, 086, 087, 088, 089,
090, 091, 092, 093, 094, 095,
096, 097, 098, 099, 100,
101, 102, 103, 104, 105,
106, 107, 108, 109, 110,
111, 112, 113, 114, 115, 116,
117, 118, 119, 120, 121,
122, 123, 124, 125, 126, 127,
128, 129, 130, 131, 132, 133,
134, 135, 136, 137, 138, 139,
140, 141, 142, 143, 144, 145,
146, 147, 148, 149, 150, 151,
152, 153, 154, 155, 156, 157,
158, 159, 160, 161, 162, 163,
164, 165, 166, 167, 168, 169,
170, 171, 172, 173, 174, 175,
176, 177, 178, 179, 180, 181,
182, 183, 184, 185, 186, 187,
188, 189, 190, 191, 192, 193,
194, 195, 196, 197, 198, 199,
200, 201, 202, 203, 204, 205,
206, 207, 208, 209, 210, 211,
212, 213, 214, 215, 216, 217,
218, 219, 220, 221, 222, 223,
224, 225, 226, 227, 228, 229,
230, 231, 232, 233, 234, 235,
236, 237, 238, 239, 240, 241,
242, 243, 244, 245, 246, 247,
248, 249, 250, 251, 252, 253,
254, 255, 256, 257, 258, 259,
260, 261, 262, 263, 264, 265,
266, 267, 268, 269, 270, 271,
272, 273, 274, 275, 276, 277,
278, 279, 280, 281, 282, 283,
284, 285, 286, 287, 288, 289,
290, 291, 292, 293, 294, 295,
296, 297, 298, 299, 300, 301,
302, 303, 304, 305, 306, 307,
308, 309, 310, 311, 312, 313,
314, 315, 316, 317, 318, 319,
320, 321, 322, 323, 324, 325,
326, 327, 328, 329, 330, 331,
332, 333, 334, 335, 336, 337,
338, 339, 340, 341, 342, 343,
344, 345, 346, 347, 348, 349,
350, 351, 352, 353, 354, 355, 356,
357, 358, 359, 360, 361, 362,
363, 364, 365, 366, 367, 368,
369, 370, 371, 372, 373, 374,
375, 376, 377, 378, 379, 380,
381, 382, 383, 384, 385, 386,
387, 388, 389, 390, 391, 392,
393, 394, 395, 396, 397, 398,
399, 400, 401, 402, 403, 404,
405, 406, 407, 408, 409, 410,
411, 412, 413, 414, 415, 416,
417, 418, 419, 420, 421, 422,
423, 424, 425, 426, 427, 428,
429, 430, 431, 432, 433, 434,
435, 436, 437, 438, 439, 440,
441, 442, 443, 444, 445, 446,
447, 448, 449, 450, 451, 452,
453, 454, 455, 456, 457, 458,
459, 460, 461, 462, 463, 464,
465, 466, 467, 468, 469, 470,
471, 472, 473, 474, 475, 476,
477, 478, 479, 480, 481, 482,
483, 484, 485, 486, 487, 488,
489, 490, 491, 492, 493, 494,
495, 496, 497, 498, 499, 500,
501, 502, 503, 504, 505, 506,
507, 508, 509, 510, 511, 512,
513, 514, 515, 516, 517, 518,
519, 520, 521, 522, 523, 524,
525, 526, 527, 528, 529, 530,
531, 532, 533, 534, 535, 536,
537, 538, 539, 540, 541, 542,
543, 544, 545, 546, 547, 548,
549, 550, 551, 552, 553, 554,
555, 556, 557, 558, 559, 560,
561, 562, 563, 564, 565, 566,
567, 568, 569, 570, 571, 572,
573, 574, 575, 576, 577.

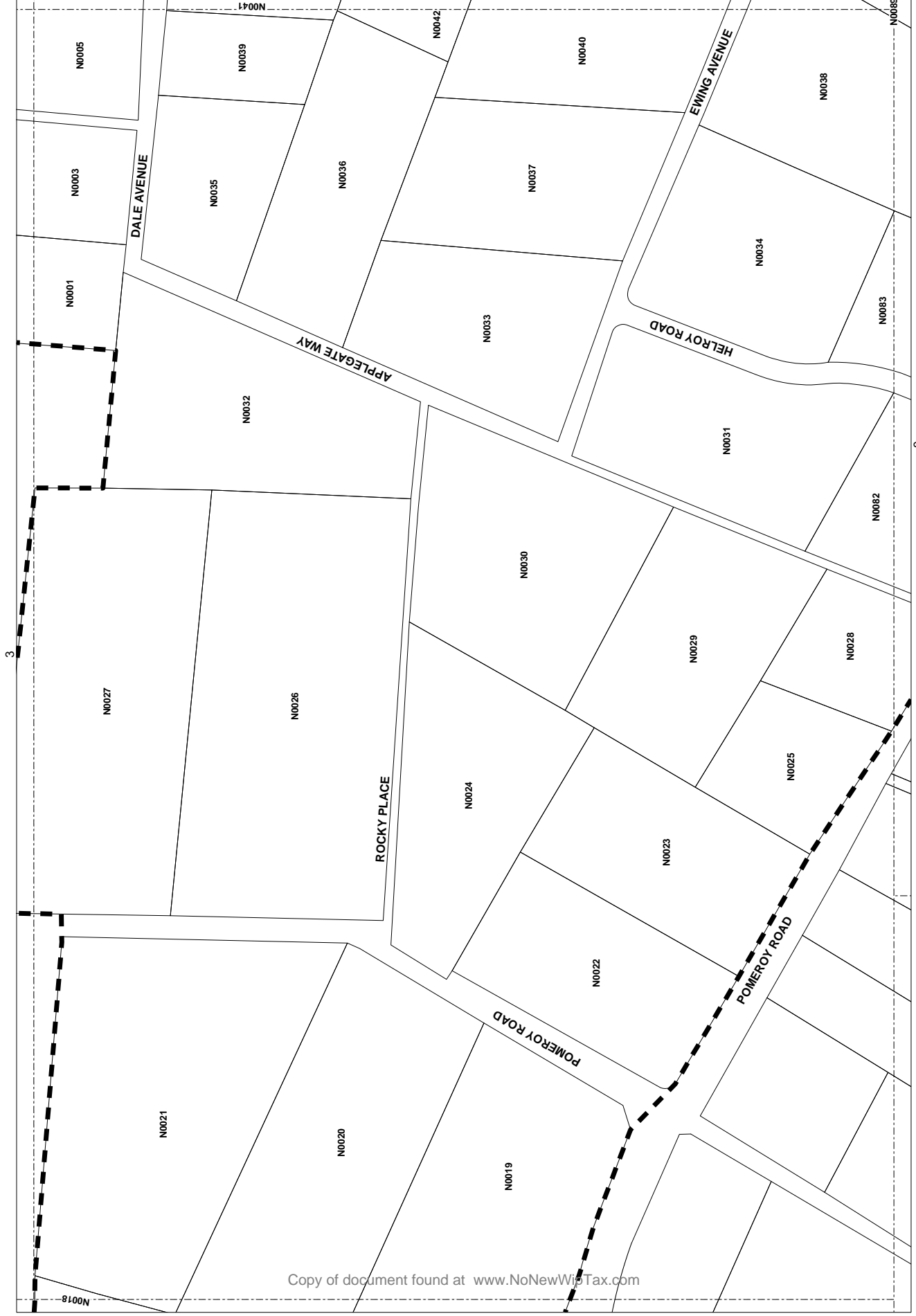





ASSESSMENT DIAGRAM

NIPOMO MESA
SUPPLEMENTAL
REVENUE DISTRICT
ASSESSMENT DISTRICT
NO.1

NIPOMO COMMUNITY
SERVICES DISTRICT
STATE OF CALIFORNIA

Legend

-  ASSESSMENT BOUNDARY
-  ASSESSOR PARCEL
-  DIAGRAM SHEET

 1 inch = 200 Feet

0 100 200

**SHEET:
7 OF 59**

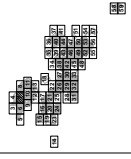





LOTS ON THIS SHEET ARE
INDEXED BY PARCEL NUMBER
MAP COUNTY OF SAN LUIS
OBISPO, CA; BK 080 PGS:
072, 078, 079, 081, 082, 083,
084, 085, 086, 087, 088, 089,
095, 101, 102, 103, 111, 121,
122, 123, 131, 132, 133, 134,
135, 141, 142, 143, 144,
151, 152, 161, 162, 163, 164,
165, 171, 172, 181, 182, 183,
184, 185, 191, 192, 193, 194,
195, 201, 202, 203, 204, 205,
206, 207, 208, 209, 210, 211,
212, 213, 214, 215, 216, 217,
218, 219, 220, 221, 222, 223,
224, 225, 226, 227, 228, 229,
230, 231, 232, 233, 234, 235,
236, 237, 238, 239, 240, 241,
242, 243, 244, 245, 246, 247,
248, 249, 250, 251, 252, 253,
254, 255, 256, 257, 258, 259,
260, 261, 262, 263, 264, 265,
266, 267, 268, 269, 270, 271,
272, 273, 274, 275, 276, 277,
278, 279, 280, 281, 282, 283,
284, 285, 286, 287, 288, 289,
290, 291, 292, 293, 294, 295,
296, 297, 298, 299, 300, 301,
302, 303, 304, 305, 306, 307,
308, 309, 310, 311, 312, 313,
314, 315, 316, 317, 318, 319,
320, 321, 322, 323, 324, 325,
326, 327, 328, 329, 330, 331,
332, 333, 334, 335, 336, 337,
338, 339, 340, 341, 342, 343,
344, 345, 346, 347, 348, 349,
350, 351, 352, 353, 354, 355,
356, 357, 358, 359, 360, 361,
362, 363, 364, 365, 366, 367,
368, 369, 370, 371, 372, 373,
374, 375, 376, 377, 378, 379,
380, 381, 382, 383, 384, 385,
386, 387, 388, 389, 390, 391,
392, 393, 394, 395, 396, 397,
398, 399, 400, 401, 402, 403,
404, 405, 406, 407, 408, 409,
410, 411, 412, 413, 414, 415,
416, 417, 418, 419, 420, 421,
422, 423, 424, 425, 426, 427,
428, 429, 430, 431, 432, 433,
434, 435, 436, 437, 438, 439,
440, 441, 442, 443, 444, 445, 446,
447, 448, 449, 450, 451, 452,
453, 454, 455, 456, 457, 458,
459, 460, 461, 462, 463, 464,
465, 466, 467, 468, 469, 470,
471, 472, 473, 474, 475, 476,
477, 478, 479, 480, 481, 482,
483, 484, 485, 486, 487, 488,
489, 490, 491, 492, 493, 494,
495, 496, 497, 498, 499, 500,
501, 502, 503, 504, 505, 506,
507, 508, 509, 510, 511, 512,
513, 514, 515, 516, 517, 518,
519, 520, 521, 522, 523, 524,
525, 526, 527, 528, 529, 530,
531, 532, 533, 534, 535, 536,
537, 538, 539, 540, 541, 542,
543, 544, 545, 546, 547, 548,
549, 550, 551, 552, 553, 554,
555, 556, 557, 558, 559, 560,
561, 562, 563, 564, 565, 566,
567, 568, 569, 570, 571, 572,
573, 574, 575, 576, 577, 578,
579, 580, 581, 582, 583, 584,
585, 586, 587, 588, 589, 590,
591, 592, 593, 594, 595, 596,
597, 598, 599, 600, 601, 602,
603, 604, 605, 606, 607, 608,
609, 610, 611, 612, 613, 614,
615, 616, 617, 618, 619, 620,
621, 622, 623, 624, 625, 626,
627, 628, 629, 630, 631, 632,
633, 634, 635, 636, 637, 638,
639, 640, 641, 642, 643, 644,
645, 646, 647, 648, 649, 650,
651, 652, 653, 654, 655, 656,
657, 658, 659, 660, 661, 662,
663, 664, 665, 666, 667, 668,
669, 670, 671, 672, 673, 674,
675, 676, 677, 678, 679, 680,
681, 682, 683, 684, 685, 686,
687, 688, 689, 690, 691, 692,
693, 694, 695, 696, 697, 698,
699, 700, 701, 702, 703, 704,
705, 706, 707, 708, 709, 710,
711, 712, 713, 714, 715, 716,
717, 718, 719, 720, 721, 722,
723, 724, 725, 726, 727, 728,
729, 730, 731, 732, 733, 734,
735, 736, 737, 738, 739, 740,
741, 742, 743, 744, 745, 746,
747, 748, 749, 750, 751, 752,
753, 754, 755, 756, 757, 758,
759, 760, 761, 762, 763, 764,
765, 766, 767, 768, 769, 770,
771, 772, 773, 774, 775, 776,
777, 778, 779, 780, 781, 782,
783, 784, 785, 786, 787, 788,
789, 790, 791, 792, 793, 794,
795, 796, 797, 798, 799, 800,
801, 802, 803, 804, 805, 806,
807, 808, 809, 810, 811, 812,
813, 814, 815, 816, 817, 818,
819, 820, 821, 822, 823, 824,
825, 826, 827, 828, 829, 830,
831, 832, 833, 834, 835, 836,
837, 838, 839, 840, 841, 842,
843, 844, 845, 846, 847, 848,
849, 850, 851, 852, 853, 854,
855, 856, 857, 858, 859, 860,
861, 862, 863, 864, 865, 866,
867, 868, 869, 870, 871, 872,
873, 874, 875, 876, 877, 878,
879, 880, 881, 882, 883, 884,
885, 886, 887, 888, 889, 890,
891, 892, 893, 894, 895, 896,
897, 898, 899, 900, 901, 902,
903, 904, 905, 906, 907, 908,
909, 910, 911, 912, 913, 914,
915, 916, 917, 918, 919, 920,
921, 922, 923, 924, 925, 926,
927, 928, 929, 930, 931, 932,
933, 934, 935, 936, 937, 938,
939, 940, 941, 942, 943, 944,
945, 946, 947, 948, 949, 950,
951, 952, 953, 954, 955, 956,
957, 958, 959, 960, 961, 962,
963, 964, 965, 966, 967, 968,
969, 970, 971, 972, 973, 974,
975, 976, 977, 978, 979, 980,
981, 982, 983, 984, 985, 986,
987, 988, 989, 990, 991, 992,
993, 994, 995, 996, 997, 998,
999, 1000



**ASSESSMENT
DIAGRAM**

NIPOMO MESA
SUPPLEMENTAL
SERVICES DISTRICT
ASSESSMENT DISTRICT
NO.1

NIPOMO COMMUNITY
SERVICES DISTRICT
STATE OF CALIFORNIA

- Legend**
-  ASSESSOR PARCEL
 -  ASSESSOR BOUNDARY
 -  ASSESSOR PARCEL
 -  DIAGRAM SHEET

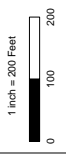

**SHEET:
8 OF 59**



LOTS ON THIS SHEET ARE
BASED UPON THE 1997
MAP COUNTY OF SAN LUIS
OBISPO, CA; BK 080 PGS:
072, 078, 079, 081, 082, 083,
084, 085, 086, 087, 088,
089, 090, 102, 103, 111, 121,
122, 123, 131, 132, 133, 134,
135, 140, 141, 142, 143, 144,
150, 151, 152, 153, 154, 155,
156, 157, 158, 159, 160, 161,
162, 163, 164, 165, 166, 167,
168, 169, 170, 171, 172, 173,
174, 175, 176, 177, 178, 179,
180, 181, 182, 183, 184, 185,
186, 187, 188, 189, 190, 191,
192, 193, 194, 195, 196, 197,
198, 199, 200, 201, 202, 203,
204, 205, 206, 207, 208, 209,
210, 211, 212, 213, 214, 215,
216, 217, 218, 219, 220, 221,
222, 223, 243, 244, 246, 247,
248, 249, 250, 251, 252, 253,
257, 311, 313, 323, 325, 326,
327, 328, 371, 372, 373, 374,
375, 376, 381, 382, 410, 411,
421, 430, 431, 440, 441, 442,
443, 444, 445, 446,
BK 091 PGS: 011, 053, 054, 055,
063, 073, 081, 081, 121, 131,
202, 233, 243, 244, 246, 247,
248, 249, 250, 251, 252, 253,
257, 311, 313, 323, 325, 326,
327, 328, 371, 372, 373, 374,
375, 376, 381, 382, 410, 411,
421, 430, 431, 440, 441, 442,
443, 444, 445, 446,
BK 092 PGS: 081, 082, 083,
120, 130, 136, 137, 138, 139,
141, 142, 143, 144, 145, 146,
147, 148, 149, 150, 152, 153,
154, 155, 156, 157, 158, 159,
201, 251, 252, 281, 282, 283,
271, 272, 282, 283, 291, 302,
303, 304, 311, 321, 331, 341,
351, 361, 371, 381, 391, 401,
385, 462, 463, 510, 512, 513,
531, 532, 533, 534, 551, 570,
571, 572, 573, 574, 575, 576,
577.

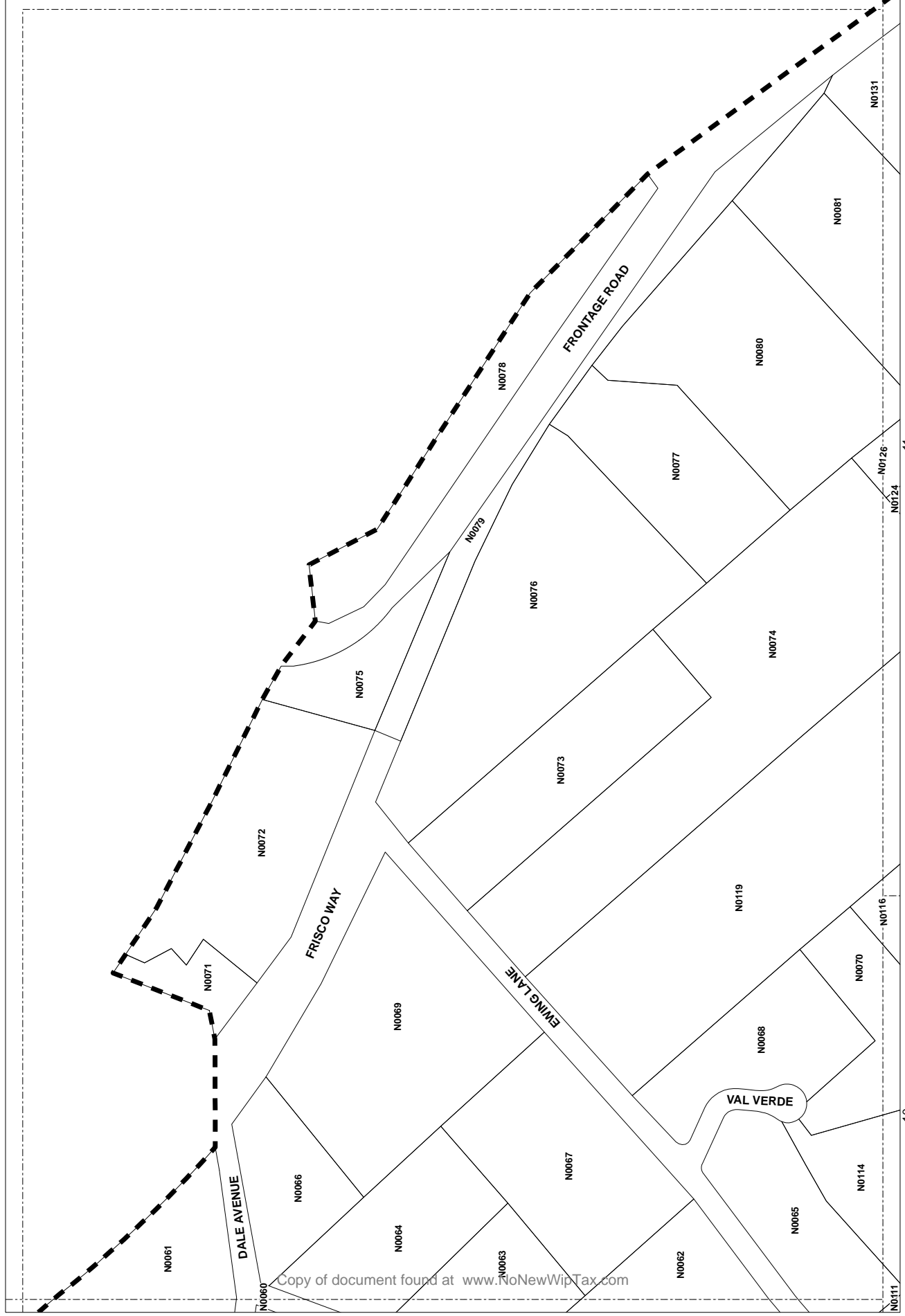

**ASSESSMENT
DIAGRAM**

NIPOMO MESA
SUPPLEMENTAL
ASSASSMENT DISTRICT
NO.1
NIPOMO COMMUNITY
SERVICES DISTRICT
STATE OF CALIFORNIA

Legend

- ASSM BOUNDARY
- ASSESSOR PARCEL
- DIAGRAM SHEET

1 inch = 200 Feet

0 100 200

**SHEET:
9 OF 59**



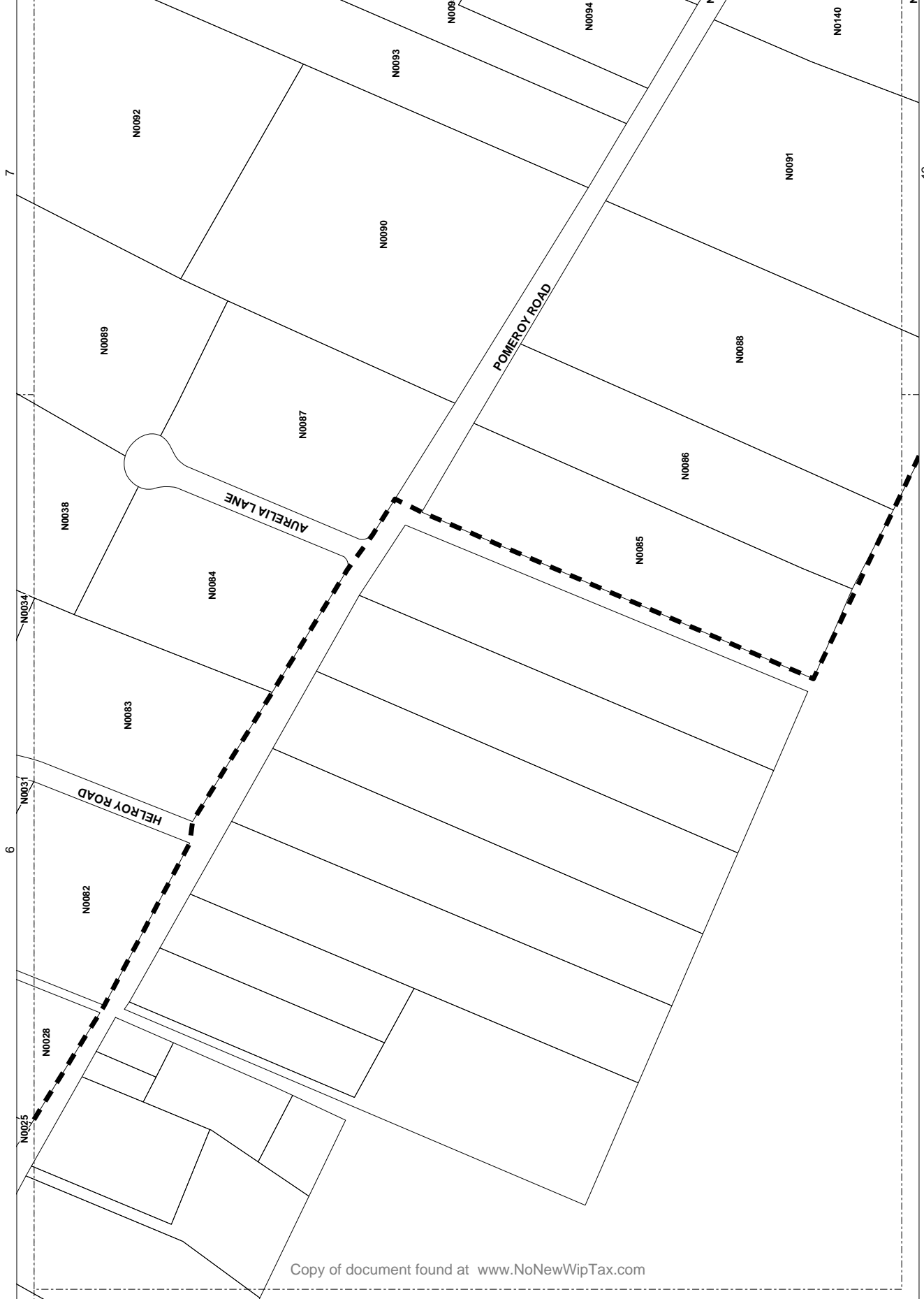

LOTS ON THIS SHEET ARE
INDEXED TO THE MAP OF
MAP COUNTY OF SAN LUIS
OBISPO, CA; BK 080 PGS:
072, 078, 079, 081, 082, 083,
084, 085, 086, 087, 088, 089,
095, 101, 102, 103, 111, 121,
122, 123, 131, 132, 133, 134,
135, 146, 147, 148, 149, 150,
151, 152, 153, 154, 155,
156, 157, 158, 159, 160, 161,
162, 163, 164, 165, 166, 167,
168, 169, 170, 171, 172, 173,
174, 175, 176, 177, 178, 179,
180, 181, 182, 183, 184, 185,
186, 187, 188, 189, 190, 191,
192, 193, 194, 195, 196, 197,
198, 199, 200, 201, 202, 203,
204, 205, 206, 207, 208, 209,
210, 211, 212, 213, 214, 215,
216, 217, 218, 219, 220, 221,
222, 223, 224, 225, 226, 227,
228, 229, 230, 231, 232, 233,
234, 235, 236, 237, 238, 239,
240, 241, 242, 243, 244, 245,
246, 247, 248, 249, 250, 251,
252, 253, 254, 255, 256, 257,
258, 259, 260, 261, 262, 263,
264, 265, 266, 267, 268, 269,
270, 271, 272, 273, 274, 275,
276, 277, 278, 279, 280, 281,
282, 283, 284, 285, 286, 287,
288, 289, 290, 291, 292, 293,
294, 295, 296, 297, 298, 299,
300, 301, 302, 303, 304, 305,
306, 307, 308, 309, 310, 311,
312, 313, 314, 315, 316, 317,
318, 319, 320, 321, 322, 323,
324, 325, 326, 327, 328, 329,
330, 331, 332, 333, 334, 335,
336, 337, 338, 339, 340, 341,
342, 343, 344, 345, 346, 347,
348, 349, 350, 351, 352, 353,
354, 355, 356, 357, 358, 359,
360, 361, 362, 363, 364, 365,
366, 367, 368, 369, 370, 371,
372, 373, 374, 375, 376, 377,
378, 379, 380, 381, 382, 383,
384, 385, 386, 387, 388, 389,
390, 391, 392, 393, 394, 395,
396, 397, 398, 399, 400, 401,
402, 403, 404, 405, 406, 407,
408, 409, 410, 411, 412, 413,
414, 415, 416, 417, 418, 419,
420, 421, 422, 423, 424, 425,
426, 427, 428, 429, 430, 431,
432, 433, 434, 435, 436, 437,
438, 439, 440, 441, 442,
443, 444, 445, 446, 447, 448,
449, 450, 451, 452, 453, 454,
455, 456, 457, 458, 459, 460,
461, 462, 463, 464, 465, 466,
467, 468, 469, 470, 471, 472,
473, 474, 475, 476, 477, 478,
479, 480, 481, 482, 483, 484,
485, 486, 487, 488, 489, 490,
491, 492, 493, 494, 495, 496,
497, 498, 499, 500, 501, 502,
503, 504, 505, 506, 507, 508,
509, 510, 511, 512, 513, 514,
515, 516, 517, 518, 519, 520,
521, 522, 523, 524, 525, 526,
527, 528, 529, 530, 531, 532,
533, 534, 535, 536, 537, 538,
539, 540, 541, 542, 543, 544,
545, 546, 547, 548, 549, 550,
551, 552, 553, 554, 555, 556,
557, 558, 559, 560, 561, 562,
563, 564, 565, 566, 567, 568,
569, 570, 571, 572, 573, 574,
575, 576, 577, 578, 579, 580,
581, 582, 583, 584, 585, 586,
587, 588, 589, 590, 591, 592,
593, 594, 595, 596, 597, 598,
599, 600, 601, 602, 603, 604,
605, 606, 607, 608, 609, 610,
611, 612, 613, 614, 615, 616,
617, 618, 619, 620, 621, 622,
623, 624, 625, 626, 627, 628,
629, 630, 631, 632, 633, 634,
635, 636, 637, 638, 639, 640,
641, 642, 643, 644, 645, 646,
647, 648, 649, 650, 651, 652,
653, 654, 655, 656, 657, 658,
659, 660, 661, 662, 663, 664,
665, 666, 667, 668, 669, 670,
671, 672, 673, 674, 675, 676,
677, 678, 679, 680, 681, 682,
683, 684, 685, 686, 687, 688,
689, 690, 691, 692, 693, 694,
695, 696, 697, 698, 699, 700,
701, 702, 703, 704, 705, 706,
707, 708, 709, 710, 711, 712,
713, 714, 715, 716, 717, 718,
719, 720, 721, 722, 723, 724,
725, 726, 727, 728, 729, 730,
731, 732, 733, 734, 735, 736,
737, 738, 739, 740, 741, 742,
743, 744, 745, 746, 747, 748,
749, 750, 751, 752, 753, 754,
755, 756, 757, 758, 759, 760,
761, 762, 763, 764, 765, 766,
767, 768, 769, 770, 771, 772,
773, 774, 775, 776, 777, 778,
779, 780, 781, 782, 783, 784,
785, 786, 787, 788, 789, 790,
791, 792, 793, 794, 795, 796,
797, 798, 799, 800, 801, 802,
803, 804, 805, 806, 807, 808,
809, 810, 811, 812, 813, 814,
815, 816, 817, 818, 819, 820,
821, 822, 823, 824, 825, 826,
827, 828, 829, 830, 831, 832,
833, 834, 835, 836, 837, 838,
839, 840, 841, 842, 843, 844,
845, 846, 847, 848, 849, 850,
851, 852, 853, 854, 855, 856,
857, 858, 859, 860, 861, 862,
863, 864, 865, 866, 867, 868,
869, 870, 871, 872, 873, 874,
875, 876, 877, 878, 879, 880,
881, 882, 883, 884, 885, 886,
887, 888, 889, 890, 891, 892,
893, 894, 895, 896, 897, 898,
899, 900, 901, 902, 903, 904,
905, 906, 907, 908, 909, 910,
911, 912, 913, 914, 915, 916,
917, 918, 919, 920, 921, 922,
923, 924, 925, 926, 927, 928,
929, 930, 931, 932, 933, 934,
935, 936, 937, 938, 939, 940,
941, 942, 943, 944, 945, 946,
947, 948, 949, 950, 951, 952,
953, 954, 955, 956, 957, 958,
959, 960, 961, 962, 963, 964,
965, 966, 967, 968, 969, 970,
971, 972, 973, 974, 975, 976,
977, 978, 979, 980, 981, 982,
983, 984, 985, 986, 987, 988,
989, 990, 991, 992, 993, 994,
995, 996, 997, 998, 999, 1000



**ASSESSMENT
DIAGRAM**

NIPOMO MESA
SUPPLEMENTAL
SERVICES DISTRICT
ASSESSMENT DISTRICT
NO.1

NIPOMO COMMUNITY
SERVICES DISTRICT
STATE OF CALIFORNIA

- Legend**
-  ASSESSMENT BOUNDARY
 -  ASSESSOR PARCEL
 -  DIAGRAM SHEET

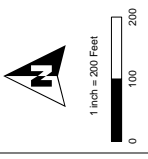

**SHEET:
11 OF 59**



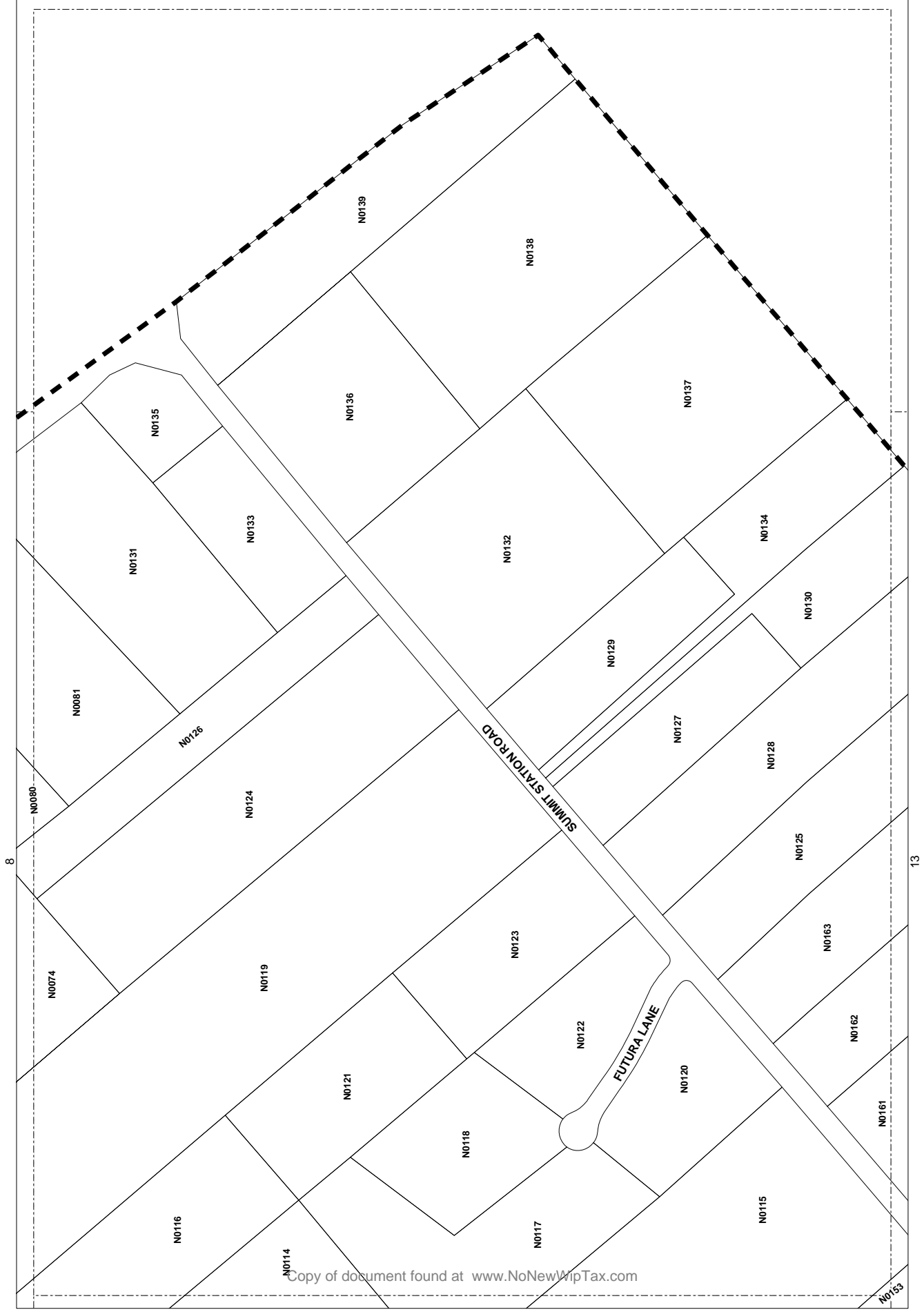

LOTS ON THIS SHEET ARE
BASED UPON THE 2017
MAP COUNTY OF SAN LUIS
OBISPO, CA; BK 080 PGS:
072, 078, 079, 081, 082, 083,
084, 085, 086, 087, 088,
089, 090, 102, 103, 111, 121,
122, 123, 131, 132, 133, 134,
135, 146, 147, 148, 149, 150,
151, 271, 272, 282, 283, 291,
302, 303, 304, 311, 321, 331, 341,
372, 381, 382, 383, 384, 385,
386, 443, 444, 445, 446,
BK 091 PGS: 011, 053, 054,
063, 073, 081, 081, 121, 131,
202, 233, 243, 244, 246, 247,
257, 258, 259, 260, 261,
267, 311, 313, 323, 325, 326,
327, 328, 371, 372, 373, 374,
375, 376, 381, 382, 410, 411,
421, 430, 431, 432, 433, 434,
431, 439, 431, 440, 441, 442,
443, 444, 445, 446,
BK 092 PGS: 081, 082, 083,
121, 131, 132, 133, 134,
141, 142, 143, 144, 145, 146,
147, 148, 149, 150, 152, 153,
154, 155, 156, 157, 158, 159,
281, 282, 283, 291, 302,
303, 304, 311, 321, 331, 341,
385, 462, 463, 510, 512, 513,
531, 532, 533, 534, 551, 570,
571, 572, 573, 574, 575, 576,
577.



**ASSESSMENT
DIAGRAM**

NIPOMO MESA
SUPPLEMENTAL
ASSESSMENT DISTRICT
NO. 1
NIPOMO COMMUNITY
SERVICES DISTRICT
STATE OF CALIFORNIA

Legend

-  ASSM BOUNDARY
-  ASSESSOR PARCEL
-  DIAGRAM SHEET

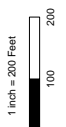

**SHEET:
12 OF 59**



LOTS ON THIS SHEET ARE
EASEMENTS AND INTERESTS
MAP COUNTY OF SAN LUIS
OBISPO, CA; BK 080 PGS:
072, 078, 079, 081, 082, 083,
084, 085, 086, 087, 088, 089,
095, 101, 102, 103, 111, 121,
122, 123, 131, 132, 133, 134,
135, 146, 147, 148, 149, 150,
151, 152, 153, 154, 155, 156,
157, 161, 162, 163, 164, 165,
166, 167, 168, 169, 170, 171,
172, 173, 174, 175, 176, 177,
178, 179, 180, 181, 182, 183,
184, 185, 186, 187, 188, 189,
190, 191, 192, 193, 194, 195,
196, 197, 198, 199, 200, 201,
202, 203, 243, 244, 246, 247,
248, 249, 250, 251, 252, 253,
257, 311, 313, 320, 325, 326,
327, 328, 371, 372, 373, 374,
375, 376, 381, 382, 410, 411,
412, 413, 414, 415, 416, 417,
421, 430, 431, 440, 441, 442,
443, 444, 445, 446,
BK 091 PGS: 011, 053, 054, 055,
063, 073, 081, 081, 121, 131,
202, 233, 243, 244, 246, 247,
248, 249, 250, 251, 252, 253,
257, 311, 313, 320, 325, 326,
327, 328, 371, 372, 373, 374,
375, 376, 381, 382, 410, 411,
412, 413, 414, 415, 416, 417,
421, 430, 431, 440, 441, 442,
443, 444, 445, 446,
BK 092 PGS: 081, 082, 083,
121, 131, 132, 133, 134,
141, 142, 143, 144, 145, 146,
147, 148, 149, 150, 152, 153,
154, 155, 156, 157, 158, 159,
201, 251, 252, 281, 282, 283,
271, 272, 282, 283, 291, 302,
303, 304, 311, 321, 331, 341,
351, 361, 371, 381, 391, 401,
385, 462, 463, 510, 512, 513,
531, 532, 533, 534, 551, 570,
571, 572, 573, 574, 575, 576,
577.

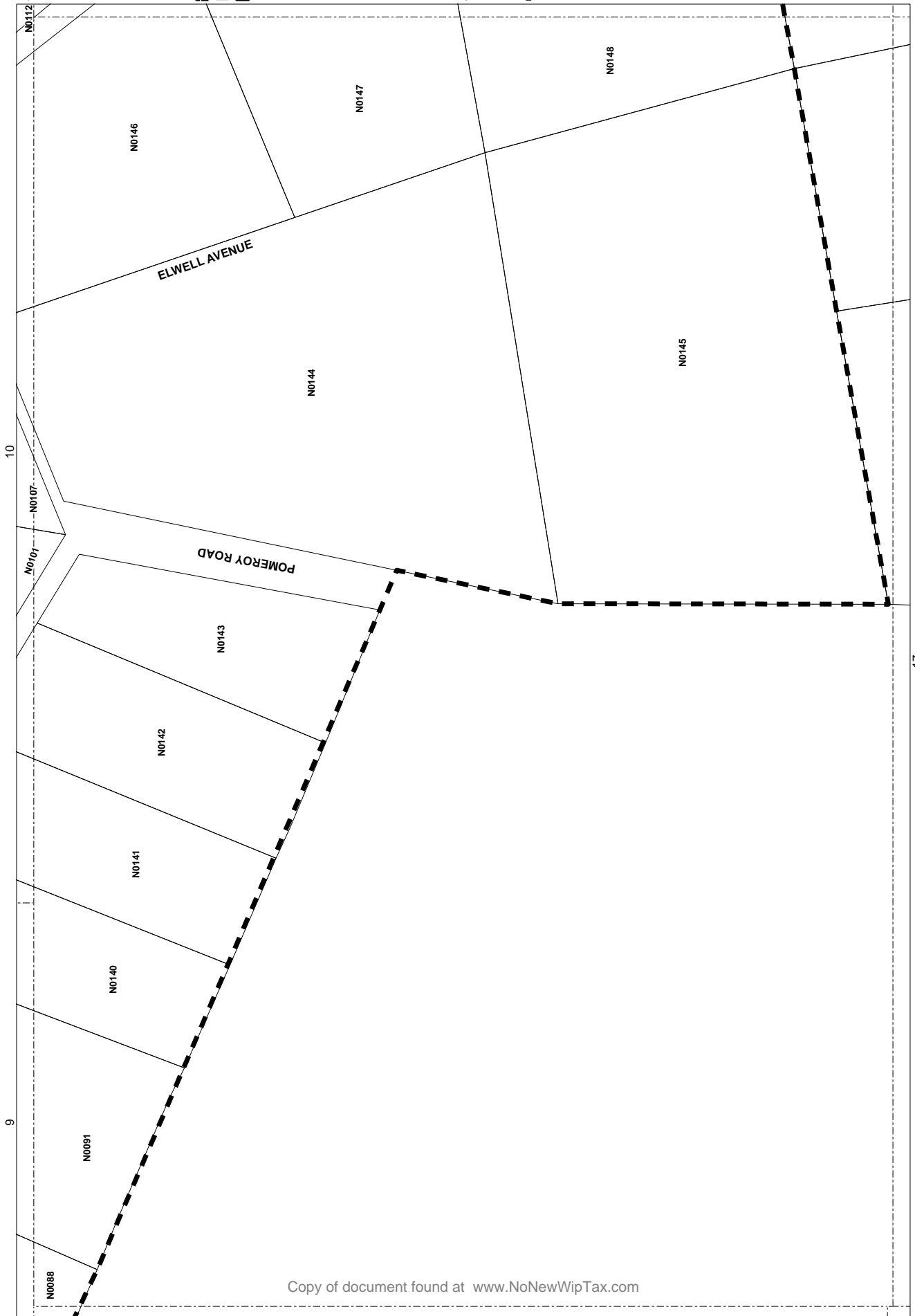





**ASSESSMENT
DIAGRAM**

NIPOMO MESA
SUPPLEMENTAL
ASSESSMENT DISTRICT
NO.1

NIPOMO COMMUNITY
SERVICES DISTRICT
STATE OF CALIFORNIA

Legend

-  ASSESSMENT BOUNDARY
-  ASSESSOR PARCEL
-  DIAGRAM SHEET



1 inch = 200 Feet

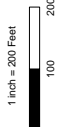

**SHEET:
13 OF 59**



LOTS ON THIS SHEET ARE
BASED UPON THE 2017
MAP COUNTY OF SAN LUIS
OBISPO, CA; BK 080 PGS:
072, 078, 079, 081, 082, 083,
084, 085, 086, 087, 088, 089,
095, 101, 102, 103, 111, 121,
122, 123, 131, 132, 133, 134,
135, 140, 141, 142, 143, 144,
150, 151, 152, 153, 154, 155,
160, 161, 162, 163, 164, 165,
171, 172, 182, 183, 184, 185,
190, 191, 192, 193, 194, 195,
200, 201, 202, 203, 204, 205,
206, 207, 208, 209, 210, 211,
212, 213, 214, 215, 216, 217,
218, 219, 220, 221, 222, 223,
224, 225, 226, 227, 228, 229,
230, 231, 232, 233, 234, 235,
236, 237, 238, 239, 240, 241,
242, 243, 244, 245, 246, 247,
248, 249, 250, 251, 252, 253,
254, 255, 256, 257, 258, 259,
260, 261, 262, 263, 264, 265,
266, 267, 268, 269, 270, 271,
272, 273, 274, 275, 276, 277,
278, 279, 280, 281, 282, 283,
284, 285, 286, 287, 288, 289,
290, 291, 292, 293, 294, 295,
296, 297, 298, 299, 300, 301,
302, 303, 304, 305, 306, 307,
308, 309, 310, 311, 312, 313,
314, 315, 316, 317, 318, 319,
320, 321, 322, 323, 324, 325,
326, 327, 328, 329, 330, 331,
332, 333, 334, 335, 336, 337,
338, 339, 340, 341, 342, 343,
344, 345, 346, 347, 348, 349,
350, 351, 352, 353, 354, 355, 356,
357, 358, 359, 360, 361, 362,
363, 364, 365, 366, 367, 368,
369, 370, 371, 372, 373, 374,
375, 376, 377, 378, 379, 380,
381, 382, 383, 384, 385, 386,
387, 388, 389, 390, 391, 392,
393, 394, 395, 396, 397, 398,
399, 400, 401, 402, 403, 404,
405, 406, 407, 408, 409, 410,
411, 412, 413, 414, 415, 416,
417, 418, 419, 420, 421, 422,
423, 424, 425, 426, 427, 428,
429, 430, 431, 432, 433, 434,
435, 436, 437, 438, 439, 440,
441, 442, 443, 444, 445, 446,
447, 448, 449, 450, 451, 452,
453, 454, 455, 456, 457, 458,
459, 460, 461, 462, 463, 464,
465, 466, 467, 468, 469, 470,
471, 472, 473, 474, 475, 476,
477, 478, 479, 480, 481, 482,
483, 484, 485, 486, 487, 488,
489, 490, 491, 492, 493, 494,
495, 496, 497, 498, 499, 500,
501, 502, 503, 504, 505, 506,
507, 508, 509, 510, 511, 512,
513, 514, 515, 516, 517, 518,
519, 520, 521, 522, 523, 524,
525, 526, 527, 528, 529, 530,
531, 532, 533, 534, 535, 536,
537, 538, 539, 540, 541, 542,
543, 544, 545, 546, 547, 548,
549, 550, 551, 552, 553, 554,
555, 556, 557, 558, 559, 560,
561, 562, 563, 564, 565, 566,
567, 568, 569, 570, 571, 572,
573, 574, 575, 576, 577.

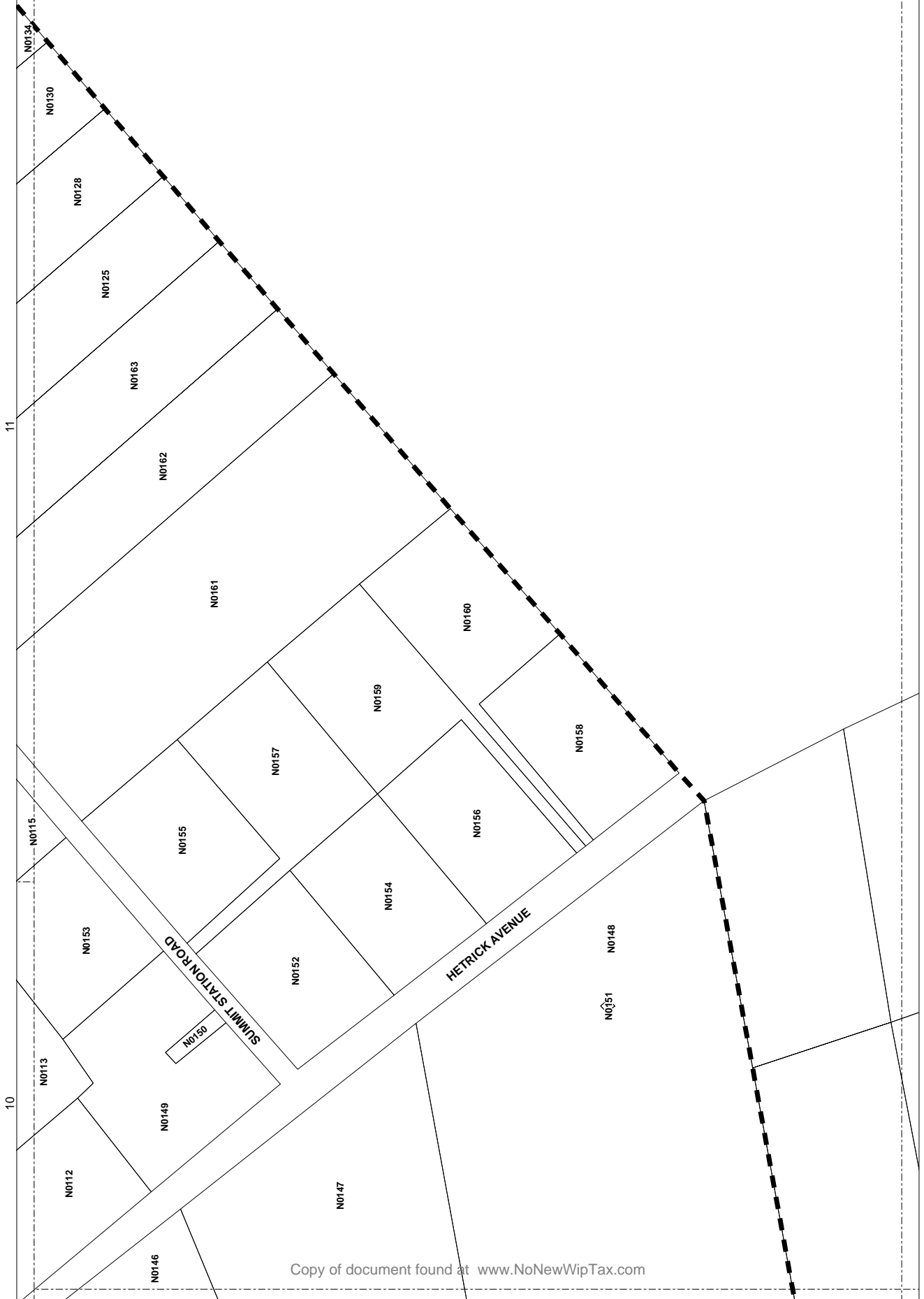



**ASSESSMENT
DIAGRAM**

NIPOMO MESA
SUPPLEMENTAL
SERVICES DISTRICT
ASSESSMENT DISTRICT
NO.1

NIPOMO COMMUNITY
SERVICES DISTRICT
STATE OF CALIFORNIA

Legend

-  ASSESSOR PARCEL
-  ASSESSOR PARCEL
-  DIAGRAM SHEET

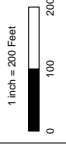

**SHEET:
14 OF 59**

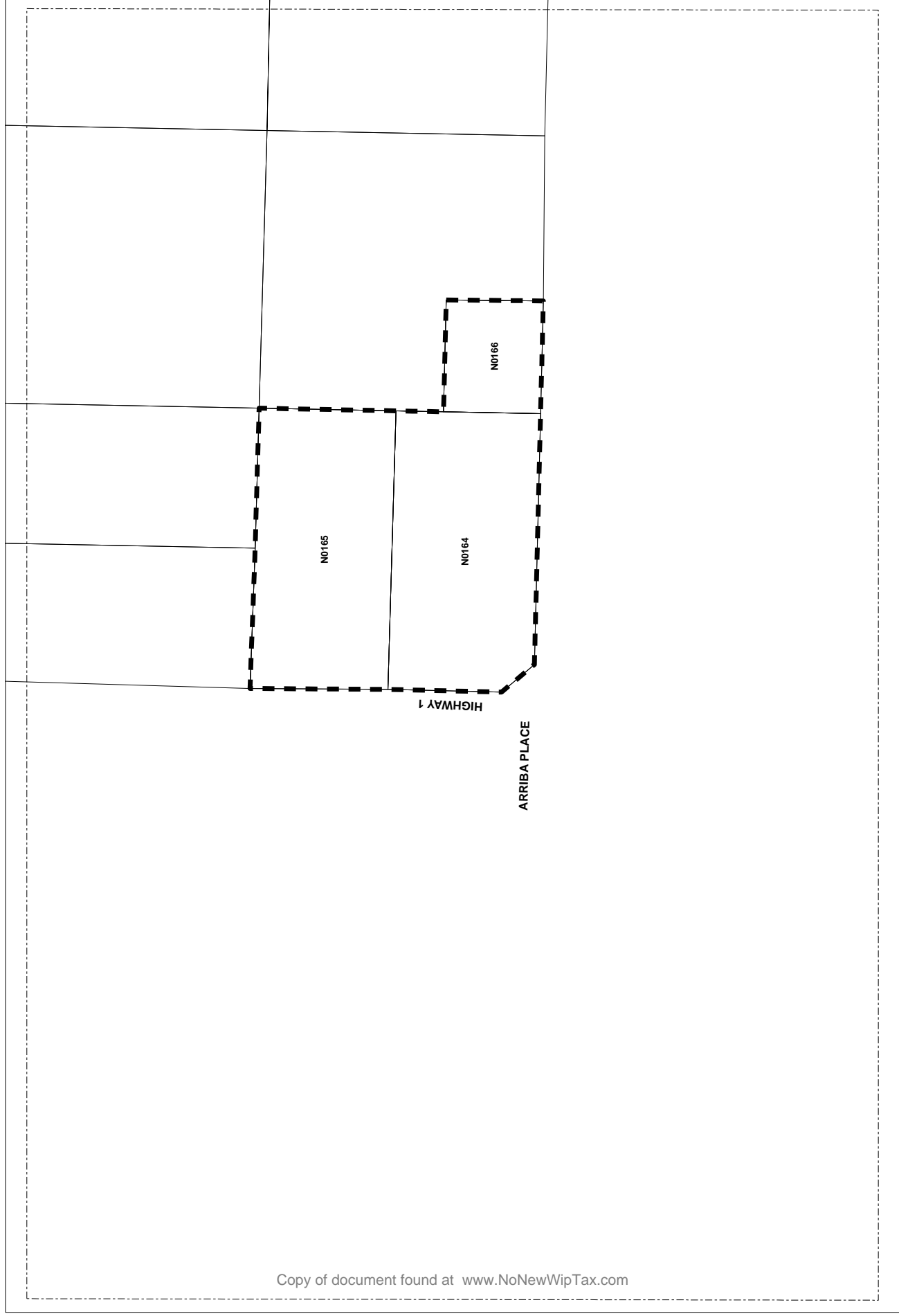



LOTS ON THIS SHEET ARE
ELECTED TO BE REVALUED
MAP COUNTY OF SAN LUIS
OBISPO, CA; BK 080 PGS:
072, 078, 079, 081, 082, 083,
084, 085, 086, 087, 088, 089,
095, 101, 102, 103, 111, 121,
122, 123, 131, 132, 133, 134,
135, 146, 147, 148, 149, 150,
151, 271, 301, 302, 303, 304,
307, 361, 362, 363, 364, 371,
372, 381, 382, 383, 384, 385,
386, 387, 388, 389, 390, 445,
BK 091 PGS: 011, 053, 054, 055,
063, 073, 081, 081, 121, 131,
202, 233, 243, 244, 246, 247,
248, 249, 250, 251, 252, 253,
257, 311, 313, 320, 325, 326,
327, 328, 371, 372, 373, 374,
375, 376, 381, 382, 410, 411,
412, 413, 414, 415, 416, 417,
421, 430, 431, 440, 441, 442,
443, 444, 445, 446,
BK 092 PGS: 081, 082, 083,
120, 121, 122, 123, 124, 125,
126, 130, 136, 137, 138, 139,
141, 142, 143, 144, 145, 146,
147, 148, 149, 150, 152, 153,
154, 155, 156, 157, 158, 159,
201, 251, 252, 281, 282, 283,
271, 272, 282, 283, 291, 302,
303, 304, 311, 321, 331, 341,
342, 343, 344, 345, 346,
385, 462, 463, 510, 512, 513,
531, 532, 533, 534, 551, 570,
571, 572, 573, 574, 575, 576,
577.

**ASSESSMENT
DIAGRAM**

NIPOMO MESA
SUPPLEMENTAL
GENERAL ASSESSMENT
ASSESSMENT DISTRICT
NO.1

NIPOMO COMMUNITY
SERVICES DISTRICT
STATE OF CALIFORNIA

- Legend**
-  ASSM BOUNDARY
 -  ASSESSOR PARCEL
 -  DIAGRAM SHEET

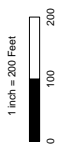

**SHEET:
17 OF 59**





LOTS ON THIS SHEET ARE
INDEXED BY PARCEL NUMBER
MAP COUNTY OF SAN LUIS
OBISPO, CA; BK 080 PGS:
072, 078, 079, 081, 082, 083,
084, 085, 086, 087, 088, 089,
095, 101, 102, 103, 111, 121,
122, 123, 131, 132, 133, 134,
135, 140, 141, 142, 143, 151,
152, 153, 161, 162, 163, 164,
307, 361, 362, 363, 364, 371,
372, 381, 382, 383, 384, 385,
BK 081 PGS: 011, 053, 054, 055,
063, 073, 081, 081, 121, 131,
202, 233, 243, 244, 246, 247,
250, 251, 252, 253, 254, 255,
257, 311, 313, 320, 326, 328,
337, 328, 371, 372, 373, 374,
375, 376, 381, 382, 410, 411,
421, 430, 431, 440, 441, 442,
443, 444, 445, 446,
BK 092 PGS: 081, 082, 083,
120, 130, 136, 137, 138, 139,
141, 142, 143, 144, 145, 146,
147, 148, 149, 150, 152, 153,
154, 155, 156, 157, 158, 159,
261, 251, 252, 261, 262, 263,
271, 272, 282, 283, 291, 302,
303, 304, 311, 321, 331, 341,
351, 361, 371, 381, 391,
395, 462, 463, 510, 512, 513,
531, 532, 533, 534, 551, 570,
571, 572, 573, 574, 575, 576,
577.



**ASSESSMENT
DIAGRAM**

NIPOMO MESA
SUPPLEMENTAL
ASSESSMENT DISTRICT
NO. 1
NIPOMO COMMUNITY
SERVICES DISTRICT
STATE OF CALIFORNIA

Legend

-  ASSM BOUNDARY
-  ASSESSOR PARCEL
-  DIAGRAM SHEET

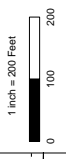

**SHEET:
19 OF 59**

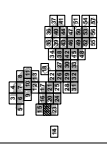

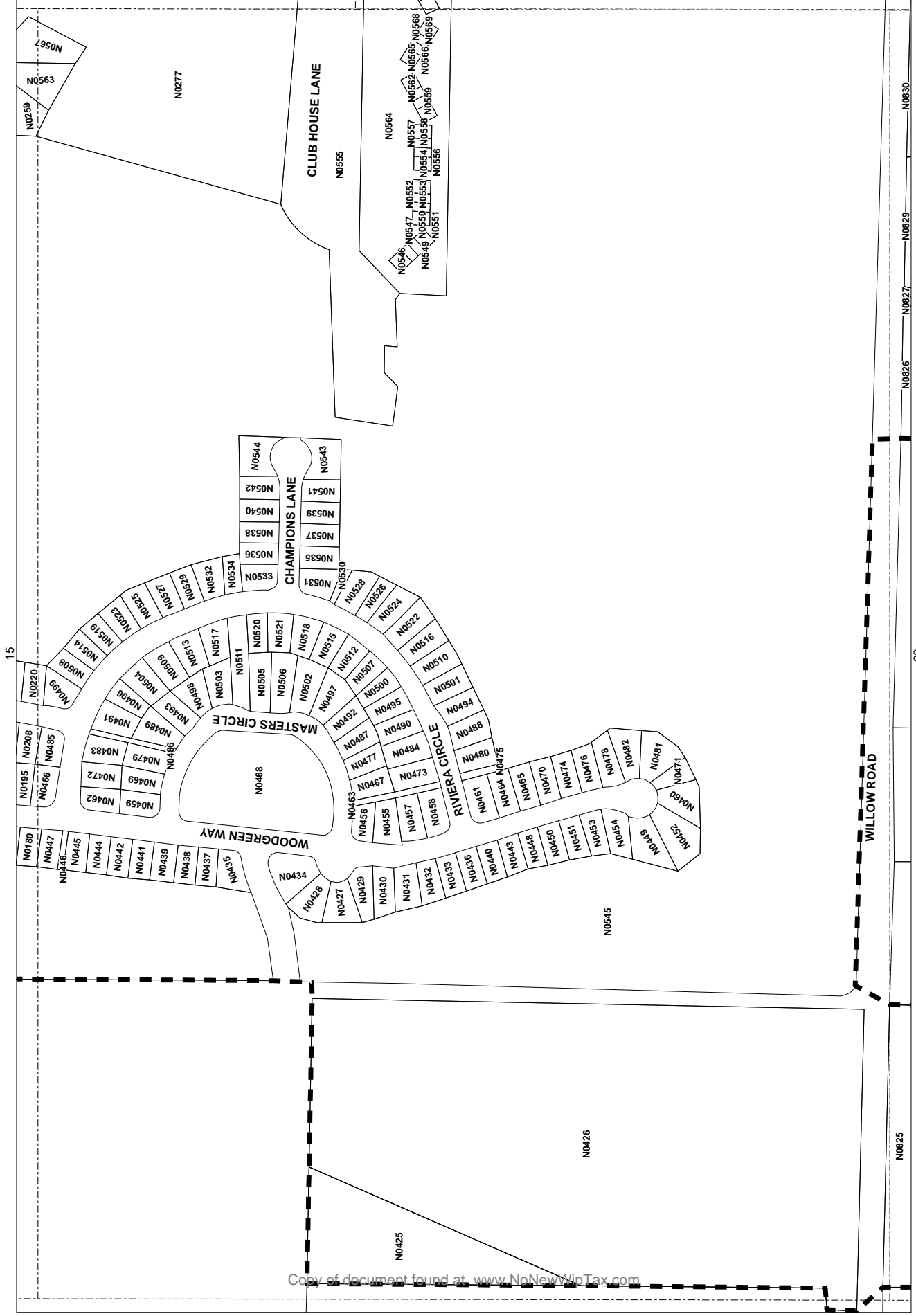

LOTS ON THIS SHEET ARE
BASED ON THE 2007
MAP COUNTY OF SAN LUIS
OBISPO, CA; BK 080 PGS:
072, 078, 079, 081, 082, 083,
084, 085, 086, 087, 088, 089,
095, 101, 102, 103, 111, 121,
122, 123, 131, 132, 133, 134,
135, 141, 142, 143, 144, 145,
151, 152, 161, 162, 163, 164,
307, 361, 362, 363, 364, 371,
372, 381, 382, 383, 384, 385,
391, 392, 393, 394, 395,
BK 081 PGS: 011, 053, 054,
063, 073, 081, 081, 121, 131,
202, 233, 243, 244, 246, 247,
251, 252, 253, 254, 255, 256,
267, 311, 313, 323, 326, 328,
329, 331, 333, 371, 372, 373, 374,
375, 376, 381, 382, 410, 411,
421, 431, 432, 433, 434, 435,
431, 439, 431, 440, 441, 442,
443, 444, 445, 446,
BK 092 PGS: 081, 082, 083,
121, 122, 123, 124, 125, 126,
129, 130, 136, 137, 138, 139,
141, 142, 143, 144, 145, 146,
147, 148, 149, 150, 152, 153,
154, 155, 156, 157, 158, 159,
281, 281, 282, 283, 281, 302,
271, 272, 282, 283, 281, 302,
303, 304, 311, 321, 321, 341,
342, 343, 344, 345, 346, 347,
385, 462, 463, 510, 512, 513,
531, 532, 533, 534, 551, 570,
571, 572, 573, 574, 575, 576,
577.



**ASSESSMENT
DIAGRAM**

NIPOMO MESA
SUPPLEMENTAL
ASSASSMENT DISTRICT
NO. 1
NIPOMO COMMUNITY
SERVICES DISTRICT
STATE OF CALIFORNIA

Legend

-  ASSM. BOUNDARY
-  ASSESSOR PARCEL
-  DIAGRAM SHEET



1 inch = 200 Feet

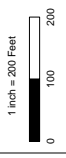

**SHEET:
21 OF 59**







































LOTS ON THIS SHEET ARE
EFFECTIVE FOR THE YEAR
MAP COUNTY OF SAN LUIS
OBISPO, CA; BK 080 PGS:
072, 078, 079, 081, 082, 083,
084, 085, 086, 087, 088, 089,
090, 091, 092, 093, 111, 121,
122, 123, 131, 132, 133, 134,
135, 141, 142, 143, 144,
151, 152, 161, 162, 163, 164,
307, 361, 362, 363, 364, 371,
372, 381, 382, 383, 384, 385,
386, 387, 388, 389, 391, 392,
BK 091 PGS: 011, 053, 054,
063, 073, 081, 081, 121, 131,
202, 233, 243, 244, 246, 247,
251, 252, 253, 254, 255, 256,
257, 311, 313, 323, 325, 326,
327, 328, 371, 372, 373, 374,
375, 376, 381, 382, 410, 411,
421, 430, 431, 440, 441, 442,
443, 444, 445, 446,
BK 092 PGS: 081, 082, 083,
151, 152, 153, 154, 155, 156,
123, 130, 136, 137, 138, 139,
141, 142, 143, 144, 145, 146,
147, 148, 149, 150, 152, 153,
154, 155, 156, 157, 158, 159,
281, 282, 283, 284, 285, 286,
271, 272, 282, 283, 291, 302,
303, 304, 311, 321, 331, 341,
351, 361, 371, 381, 391, 401,
385, 462, 463, 510, 512, 513,
531, 532, 533, 534, 551, 570,
571, 572, 573, 574, 575, 576,
577.



**ASSESSMENT
DIAGRAM**

NIPOMO MESA
SUPPLEMENTAL
ASSASSMENT DISTRICT
NO.1

NIPOMO COMMUNITY
SERVICES DISTRICT
STATE OF CALIFORNIA

- Legend**
-  ASSESSOR PARCEL
 -  ASSESSOR PARCEL
 -  ASSESSOR PARCEL
 -  ASSESSOR PARCEL
 -  ASSESSOR PARCEL
 -  ASSESSOR PARCEL
 -  ASSESSOR PARCEL
 -  ASSESSOR PARCEL
 -  ASSESSOR PARCEL
 -  ASSESSOR PARCEL
 -  ASSESSOR PARCEL
 -  ASSESSOR PARCEL
 -  ASSESSOR PARCEL
 -  ASSESSOR PARCEL
 -  ASSESSOR PARCEL
 -  ASSESSOR PARCEL
 -  ASSESSOR PARCEL
 -  ASSESSOR PARCEL
 -  ASSESSOR PARCEL
 -  ASSESSOR PARCEL
 -  ASSESSOR PARCEL
 -  ASSESSOR PARCEL
 -  ASSESSOR PARCEL
 -  ASSESSOR PARCEL
 -  ASSESSOR PARCEL
 -  ASSESSOR PARCEL
 -  ASSESSOR PARCEL
 -  ASSESSOR PARCEL
 -  ASSESSOR PARCEL
 -  ASSESSOR PARCEL
 -  ASSESSOR PARCEL
 -  ASSESSOR PARCEL
 -  ASSESSOR PARCEL
 -  ASSESSOR PARCEL
 -  ASSESSOR PARCEL
 -  ASSESSOR PARCEL
 -  ASSESSOR PARCEL



1 inch = 200 Feet
0 100 200

**SHEET:
22 OF 59**



LOTS ON THIS SHEET ARE
EFFECTIVE FOR THE YEAR 2018
MAP COUNTY OF SAN LUIS
OBISPO, CA; BK 080 PGS:
072, 078, 079, 081, 082, 083,
084, 085, 086, 087, 088, 089,
090, 091, 092, 093, 094,
095, 101, 102, 103, 111, 121,
122, 123, 131, 132, 133, 134,
135, 141, 142, 143, 144, 145,
151, 152, 161, 162, 163, 164,
171, 172, 181, 182, 183, 184,
191, 192, 193, 194, 195,
201, 202, 203, 204, 205,
211, 212, 213, 214, 215,
221, 222, 223, 224, 225,
231, 232, 233, 234, 235,
241, 242, 243, 244, 245,
251, 252, 253, 254, 255,
261, 262, 263, 264, 265,
271, 272, 282, 283, 284, 285,
291, 292, 293, 294, 295,
301, 302, 303, 304, 305,
311, 312, 313, 314, 315,
321, 322, 323, 324, 325,
331, 332, 333, 334, 335,
341, 342, 343, 344, 345,
351, 352, 353, 354, 355, 356,
361, 362, 363, 364, 365, 366,
371, 372, 373, 374, 375,
381, 382, 383, 384, 385,
391, 392, 393, 394, 395,
401, 402, 403, 404, 405,
411, 412, 413, 414, 415,
421, 422, 423, 424, 425,
431, 432, 433, 434, 435,
441, 442, 443, 444, 445, 446,
451, 452, 453, 454, 455,
461, 462, 463, 464, 465,
471, 472, 473, 474, 475,
481, 482, 483, 484, 485,
491, 492, 493, 494, 495,
501, 502, 503, 504, 505,
511, 512, 513, 514, 515,
521, 522, 523, 524, 525,
531, 532, 533, 534, 535, 536,
541, 542, 543, 544, 545, 546,
551, 552, 553, 554, 555, 556,
561, 562, 563, 564, 565, 566,
571, 572, 573, 574, 575, 576,
577.



18

26

21

25

WILLOW ROAD



N0545

ASSESSMENT DIAGRAM

NIPOMO MESA
SUPPLEMENTAL
ASSASSMENT DISTRICT
NO.1

NIPOMO COMMUNITY
SERVICES DISTRICT
STATE OF CALIFORNIA

Legend

-  ASSESSOR PARCEL
-  ASSESSOR PARCEL
-  DIAGRAM SHEET

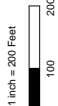

SHEET:
23 OF 59



LOTS ON THIS SHEET ARE
 LISTED BY PARCEL NUMBER
 MAP COUNTY OF SAN LUIS
 OBISPO, CA; BK 080 PGS:
 072, 078, 079, 081, 082, 083,
 084, 085, 086, 087, 088, 089,
 095, 101, 102, 103, 111, 121,
 122, 123, 131, 132, 133, 134,
 135, 140, 141, 142, 143, 144,
 151, 152, 153, 154, 155, 156,
 307, 361, 362, 363, 364, 371,
 372, 381, 382, 383, 384, 385,
 386, 387, 388, 389, 390, 391,
 BK 091 PGS: 011, 053, 054, 055,
 063, 073, 081, 081, 121, 131,
 202, 233, 243, 244, 246, 247,
 250, 251, 252, 253, 254, 255,
 297, 311, 313, 320, 325, 326,
 337, 328, 371, 372, 373, 374,
 375, 376, 381, 382, 410, 411,
 412, 413, 414, 415, 416, 417,
 421, 430, 431, 440, 441, 442,
 443, 444, 445, 446,
 BK 092 PGS: 081, 082, 083,
 150, 151, 152, 153, 154, 155,
 120, 130, 136, 137, 138, 139,
 141, 142, 143, 144, 145, 146,
 147, 148, 149, 150, 152, 153,
 154, 155, 156, 157, 158, 159,
 281, 282, 283, 284, 285, 286,
 271, 272, 282, 283, 281, 302,
 303, 304, 311, 321, 331, 341,
 351, 361, 371, 381, 391, 401,
 385, 462, 463, 510, 512, 513,
 531, 532, 533, 534, 554, 551, 570,
 571, 572, 573, 574, 575, 576,
 577.





**ASSESSMENT
DIAGRAM**

NIPOMO MESA
SUPPLEMENTAL
ASSASSMENT DISTRICT
NO.1

NIPOMO COMMUNITY
SERVICES DISTRICT
STATE OF CALIFORNIA

Legend

-  ASSESSMENT BOUNDARY
-  ASSESSOR PARCEL
-  DIAGRAM SHEET

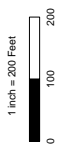

**SHEET:
25 OF 59**





LOTS ON THIS SHEET ARE
IDENTIFIED BY THE
MAP COUNTY OF SAN LUIS
OBISPO, CA; BK 080 PGS:
072, 078, 079, 081, 082, 083,
084, 085, 086, 087, 088, 089,
090, 091, 092, 093, 094, 095,
096, 097, 098, 099, 100, 101,
102, 103, 104, 105, 106, 107,
108, 109, 110, 111, 112, 113,
114, 115, 116, 117, 118, 119,
120, 121, 122, 123, 124, 125, 126,
127, 128, 129, 130, 131, 132,
133, 134, 135, 136, 137, 138,
139, 140, 141, 142, 143, 144,
145, 146, 147, 148, 149, 150,
151, 152, 153, 154, 155, 156,
157, 158, 159, 160, 161, 162,
163, 164, 165, 166, 167, 168,
169, 170, 171, 172, 173, 174,
175, 176, 177, 178, 179, 180,
181, 182, 183, 184, 185, 186,
187, 188, 189, 190, 191, 192,
193, 194, 195, 196, 197, 198,
199, 200, 201, 202, 203, 204,
205, 206, 207, 208, 209, 210,
211, 212, 213, 214, 215, 216,
217, 218, 219, 220, 221, 222,
223, 224, 225, 226, 227, 228,
229, 230, 231, 232, 233, 234,
235, 236, 237, 238, 239, 240,
241, 242, 243, 244, 245, 246,
247, 248, 249, 250, 251, 252,
253, 254, 255, 256, 257, 258,
259, 260, 261, 262, 263, 264,
265, 266, 267, 268, 269, 270,
271, 272, 273, 274, 275, 276,
277, 278, 279, 280, 281, 282,
283, 284, 285, 286, 287, 288,
289, 290, 291, 292, 293, 294,
295, 296, 297, 298, 299, 300,
301, 302, 303, 304, 305, 306,
307, 308, 309, 310, 311, 312,
313, 314, 315, 316, 317, 318,
319, 320, 321, 322, 323, 324,
325, 326, 327, 328, 329, 330,
331, 332, 333, 334, 335, 336,
337, 338, 339, 340, 341, 342,
343, 344, 345, 346, 347, 348,
349, 350, 351, 352, 353, 354,
355, 356, 357, 358, 359, 360,
361, 362, 363, 364, 365, 366,
367, 368, 369, 370, 371, 372,
373, 374, 375, 376, 377, 378,
379, 380, 381, 382, 383, 384,
385, 386, 387, 388, 389, 390,
391, 392, 393, 394, 395, 396,
397, 398, 399, 400, 401, 402,
403, 404, 405, 406, 407, 408,
409, 410, 411, 412, 413,
414, 415, 416, 417, 418, 419,
420, 421, 422, 423, 424, 425,
426, 427, 428, 429, 430, 431,
432, 433, 434, 435, 436, 437,
438, 439, 440, 441, 442,
443, 444, 445, 446, 447, 448,
449, 450, 451, 452, 453, 454,
455, 456, 457, 458, 459, 460,
461, 462, 463, 464, 465, 466,
467, 468, 469, 470, 471, 472,
473, 474, 475, 476, 477, 478,
479, 480, 481, 482, 483, 484,
485, 486, 487, 488, 489, 490,
491, 492, 493, 494, 495, 496,
497, 498, 499, 500, 501, 502,
503, 504, 505, 506, 507, 508,
509, 510, 511, 512, 513, 514,
515, 516, 517, 518, 519, 520,
521, 522, 523, 524, 525, 526,
527, 528, 529, 530, 531, 532,
533, 534, 535, 536, 537, 538,
539, 540, 541, 542, 543, 544,
545, 546, 547, 548, 549, 550,
551, 552, 553, 554, 555, 556,
557, 558, 559, 560, 561, 562,
563, 564, 565, 566, 567, 568,
569, 570, 571, 572, 573, 574,
575, 576, 577, 578, 579, 580,
581, 582, 583, 584, 585, 586,
587, 588, 589, 590, 591, 592,
593, 594, 595, 596, 597, 598,
599, 600.



**ASSESSMENT
DIAGRAM**

NIPOMO MESA
SUPPLEMENTAL
ASSASSMENT DISTRICT
NO.1
NIPOMO COMMUNITY
SERVICES DISTRICT
STATE OF CALIFORNIA

Legend

-  ASSESSMENT BOUNDARY
-  ASSESSOR PARCEL
-  DIAGRAM SHEET



1 inch = 200 Feet

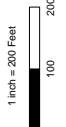

**SHEET:
27 OF 59**

38

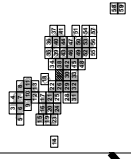

LOTS ON THIS SHEET ARE
BASED UPON THE 1991
MAP COUNTY OF SAN LUIS
OBISPO, CA; BK 080 PGS:
072, 078, 079, 081, 082, 083,
084, 085, 086, 087, 088, 089,
090, 091, 092, 093, 094, 095,
096, 097, 098, 099, 100, 101,
102, 103, 104, 105, 106, 107,
108, 109, 110, 111, 112, 113,
114, 115, 116, 117, 118, 119,
120, 121, 122, 123, 124, 125,
126, 127, 128, 129, 130, 131,
132, 133, 134, 135, 136, 137,
138, 139, 140, 141, 142, 143,
144, 145, 146, 147, 148, 149,
150, 151, 152, 153, 154, 155,
156, 157, 158, 159, 160, 161,
162, 163, 164, 165, 166, 167,
168, 169, 170, 171, 172, 173,
174, 175, 176, 177, 178, 179,
180, 181, 182, 183, 184, 185,
186, 187, 188, 189, 190, 191,
192, 193, 194, 195, 196, 197,
198, 199, 200, 201, 202, 203,
204, 205, 206, 207, 208, 209,
210, 211, 212, 213, 214, 215,
216, 217, 218, 219, 220, 221,
222, 223, 224, 225, 226, 227,
228, 229, 230, 231, 232, 233,
234, 235, 236, 237, 238, 239,
240, 241, 242, 243, 244, 245,
246, 247, 248, 249, 250, 251,
252, 253, 254, 255, 256, 257,
258, 259, 260, 261, 262, 263,
264, 265, 266, 267, 268, 269,
270, 271, 272, 273, 274, 275,
276, 277, 278, 279, 280, 281,
282, 283, 284, 285, 286, 287,
288, 289, 290, 291, 292, 293,
294, 295, 296, 297, 298, 299,
300, 301, 302, 303, 304, 305,
306, 307, 308, 309, 310, 311,
312, 313, 314, 315, 316, 317,
318, 319, 320, 321, 322, 323,
324, 325, 326, 327, 328, 329,
330, 331, 332, 333, 334, 335,
336, 337, 338, 339, 340, 341,
342, 343, 344, 345, 346, 347,
348, 349, 350, 351, 352, 353,
354, 355, 356, 357, 358, 359,
360, 361, 362, 363, 364, 365,
366, 367, 368, 369, 370, 371,
372, 373, 374, 375, 376, 377,
378, 379, 380, 381, 382, 383,
384, 385, 386, 387, 388, 389, 390,
391, 392, 393, 394, 395, 396,
397, 398, 399, 400, 401, 402,
403, 404, 405, 406, 407, 408,
409, 410, 411, 412, 413,
414, 415, 416, 417, 418, 419,
420, 421, 422, 423, 424, 425,
426, 427, 428, 429, 430, 431,
432, 433, 434, 435, 436, 437,
438, 439, 440, 441, 442, 443,
444, 445, 446, 447, 448, 449,
450, 451, 452, 453, 454, 455,
456, 457, 458, 459, 460, 461,
462, 463, 464, 465, 466, 467,
468, 469, 470, 471, 472, 473,
474, 475, 476, 477, 478, 479,
480, 481, 482, 483, 484, 485,
486, 487, 488, 489, 490, 491,
492, 493, 494, 495, 496, 497,
498, 499, 500, 501, 502, 503,
504, 505, 506, 507, 508, 509,
510, 511, 512, 513, 514, 515,
516, 517, 518, 519, 520, 521,
522, 523, 524, 525, 526, 527,
528, 529, 530, 531, 532, 533,
534, 535, 536, 537, 538, 539,
540, 541, 542, 543, 544, 545, 546,
547, 548, 549, 550, 551, 552,
553, 554, 555, 556, 557, 558,
559, 560, 561, 562, 563, 564,
565, 566, 567, 568, 569, 570,
571, 572, 573, 574, 575, 576,
577, 578, 579, 580, 581, 582,
583, 584, 585, 586, 587, 588,
589, 590, 591, 592, 593, 594,
595, 596, 597, 598, 599, 600.



Copy of document found at www.NoNewWipTax.com

22

26

29









30

**ASSESSMENT
DIAGRAM**

NIPOMO MESA
SUPPLEMENTAL
SERVICES DISTRICT
ASSESSMENT DISTRICT
NO.1

NIPOMO COMMUNITY
SERVICES DISTRICT
STATE OF CALIFORNIA

Legend

-  ASSESSOR PARCEL
-  ASSESSOR PARCEL
-  ASSESSOR PARCEL
-  ASSESSOR PARCEL
-  ASSESSOR PARCEL
-  ASSESSOR PARCEL
-  ASSESSOR PARCEL
-  ASSESSOR PARCEL



1 inch = 200 Feet

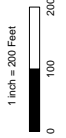

**SHEET:
28 OF 59**

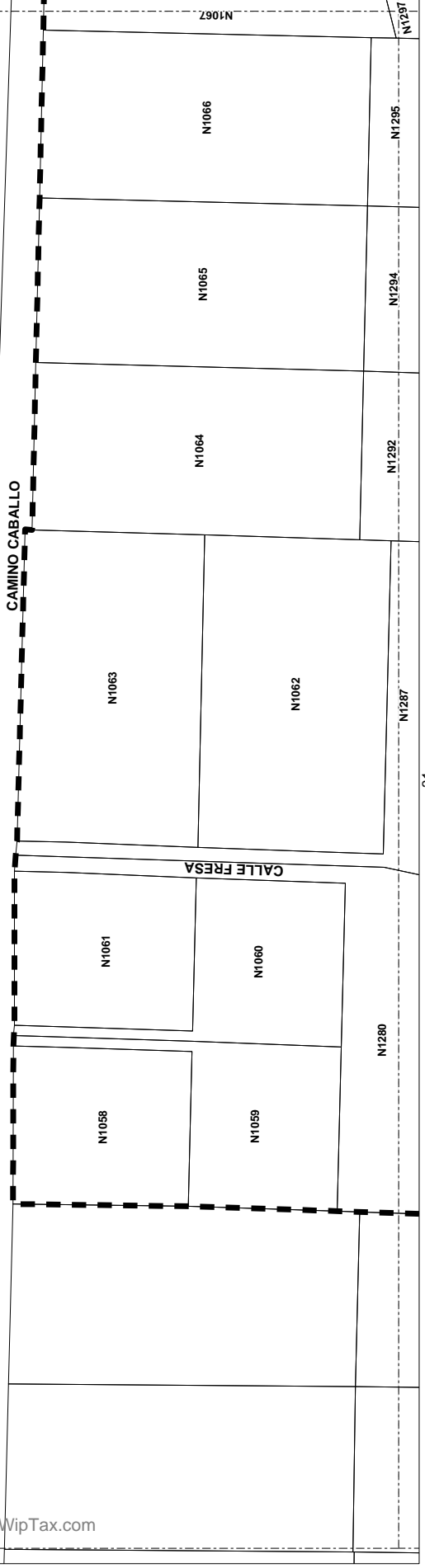
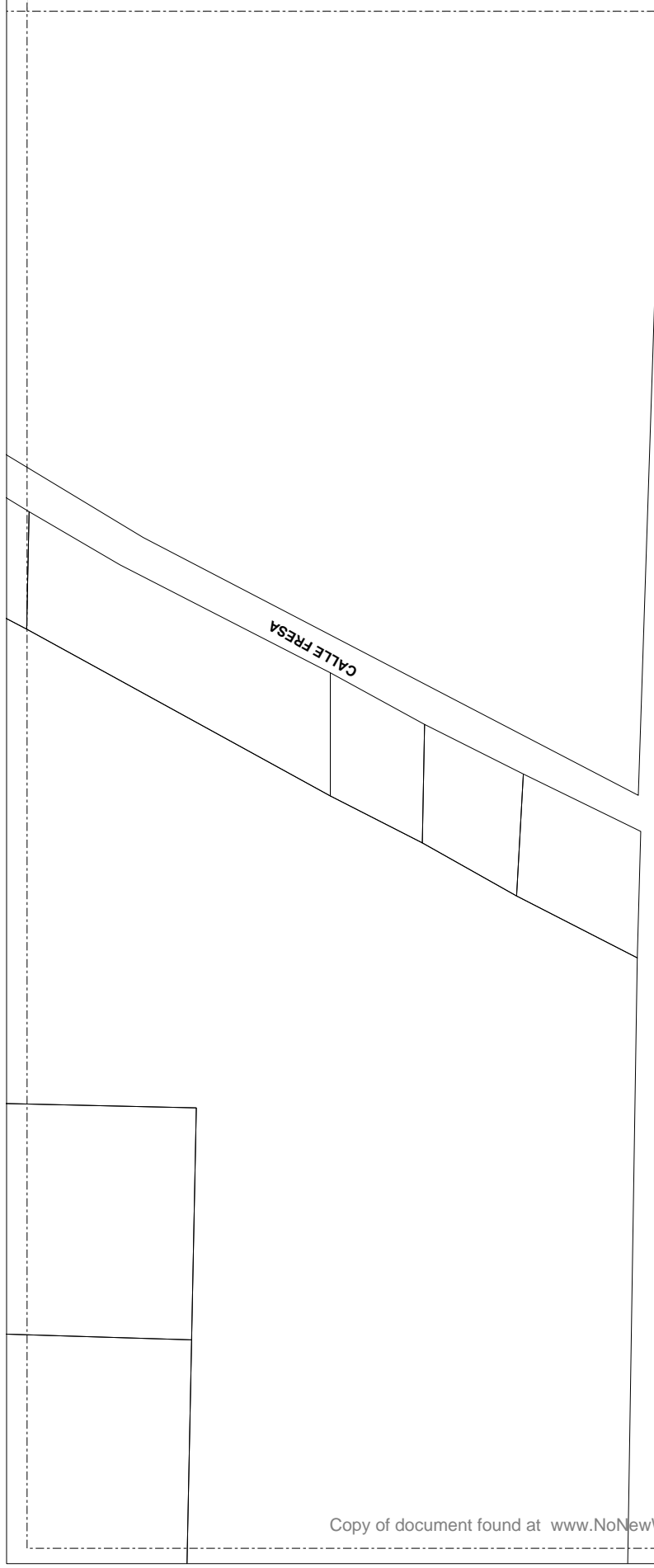

LOTS ON THIS SHEET ARE
NOT TO BE USED FOR
MAP COUNTY OF SAN LUIS
OBISPO, CA; BK 080 PGS:
072, 078, 079, 081, 082, 083,
084, 085, 086, 087, 088, 089,
090, 091, 102, 103, 111, 121,
122, 123, 131, 132, 133, 134,
135, 136, 141, 142, 143, 144,
145, 146, 147, 148, 149, 150,
151, 152, 153, 154, 155, 156,
157, 158, 159, 160, 161, 162,
163, 164, 165, 166, 167, 168,
169, 170, 171, 172, 173, 174,
175, 176, 177, 178, 179, 180,
181, 182, 183, 184, 185, 186,
187, 188, 189, 190, 191, 192,
193, 194, 195, 196, 197, 198,
199, 200, 201, 202, 203, 204,
205, 206, 207, 208, 209, 210,
211, 212, 213, 214, 215, 216,
217, 218, 219, 220, 221, 222,
223, 224, 225, 226, 227, 228,
229, 230, 231, 232, 233, 234,
235, 236, 237, 238, 239, 240,
241, 242, 243, 244, 245, 246,
247, 248, 249, 250, 251, 252,
253, 254, 255, 256, 257, 258,
259, 260, 261, 262, 263, 264,
265, 266, 267, 268, 269, 270,
271, 272, 273, 274, 275, 276,
277, 278, 279, 280, 281, 282,
283, 284, 285, 286, 287, 288,
289, 290, 291, 292, 293, 294,
295, 296, 297, 298, 299, 300,
301, 302, 303, 304, 305, 306,
307, 308, 309, 310, 311, 312,
313, 314, 315, 316, 317, 318,
319, 320, 321, 322, 323, 324,
325, 326, 327, 328, 329, 330,
331, 332, 333, 334, 335, 336,
337, 338, 339, 340, 341, 342,
343, 344, 345, 346, 347, 348,
349, 350, 351, 352, 353, 354,
355, 356, 357, 358, 359, 360,
361, 362, 363, 364, 365, 366,
367, 368, 369, 370, 371, 372,
373, 374, 375, 376, 377, 378,
379, 380, 381, 382, 383, 384,
385, 386, 387, 388, 389, 390,
391, 392, 393, 394, 395, 396,
397, 398, 399, 400, 401, 402,
403, 404, 405, 406, 407, 408,
409, 410, 411, 412, 413,
414, 415, 416, 417, 418, 419,
420, 421, 422, 423, 424, 425,
426, 427, 428, 429, 430, 431,
432, 433, 434, 435, 436, 437,
438, 439, 440, 441, 442,
443, 444, 445, 446, 447, 448,
449, 450, 451, 452, 453, 454,
455, 456, 457, 458, 459, 460,
461, 462, 463, 464, 465, 466,
467, 468, 469, 470, 471, 472,
473, 474, 475, 476, 477, 478,
479, 480, 481, 482, 483, 484,
485, 486, 487, 488, 489, 490,
491, 492, 493, 494, 495, 496,
497, 498, 499, 500, 501, 502,
503, 504, 505, 506, 507, 508,
509, 510, 511, 512, 513, 514,
515, 516, 517, 518, 519, 520,
521, 522, 523, 524, 525, 526,
527, 528, 529, 530, 531, 532,
533, 534, 535, 536, 537, 538,
539, 540, 541, 542, 543, 544,
545, 546, 547, 548, 549, 550,
551, 552, 553, 554, 555, 556,
557, 558, 559, 560, 561, 562,
563, 564, 565, 566, 567, 568,
569, 570, 571, 572, 573, 574,
575, 576, 577, 578, 579, 580,
581, 582, 583, 584, 585, 586,
587, 588, 589, 590, 591, 592,
593, 594, 595, 596, 597, 598,
599, 600, 601, 602, 603, 604,
605, 606, 607, 608, 609, 610,
611, 612, 613, 614, 615, 616,
617, 618, 619, 620, 621, 622,
623, 624, 625, 626, 627, 628,
629, 630, 631, 632, 633, 634,
635, 636, 637, 638, 639, 640,
641, 642, 643, 644, 645, 646,
647, 648, 649, 650, 651, 652,
653, 654, 655, 656, 657, 658,
659, 660, 661, 662, 663, 664,
665, 666, 667, 668, 669, 670,
671, 672, 673, 674, 675, 676,
677, 678, 679, 680, 681, 682,
683, 684, 685, 686, 687, 688,
689, 690, 691, 692, 693, 694,
695, 696, 697, 698, 699, 700,
701, 702, 703, 704, 705, 706,
707, 708, 709, 710, 711, 712,
713, 714, 715, 716, 717, 718,
719, 720, 721, 722, 723, 724,
725, 726, 727, 728, 729, 730,
731, 732, 733, 734, 735, 736,
737, 738, 739, 740, 741, 742,
743, 744, 745, 746, 747, 748,
749, 750, 751, 752, 753, 754,
755, 756, 757, 758, 759, 760,
761, 762, 763, 764, 765, 766,
767, 768, 769, 770, 771, 772,
773, 774, 775, 776, 777, 778,
779, 780, 781, 782, 783, 784,
785, 786, 787, 788, 789, 790,
791, 792, 793, 794, 795, 796,
797, 798, 799, 800, 801, 802,
803, 804, 805, 806, 807, 808,
809, 810, 811, 812, 813, 814,
815, 816, 817, 818, 819, 820,
821, 822, 823, 824, 825, 826,
827, 828, 829, 830, 831, 832,
833, 834, 835, 836, 837, 838,
839, 840, 841, 842, 843, 844,
845, 846, 847, 848, 849, 850,
851, 852, 853, 854, 855, 856,
857, 858, 859, 860, 861, 862,
863, 864, 865, 866, 867, 868,
869, 870, 871, 872, 873, 874,
875, 876, 877, 878, 879, 880,
881, 882, 883, 884, 885, 886,
887, 888, 889, 890, 891, 892,
893, 894, 895, 896, 897, 898,
899, 900, 901, 902, 903, 904,
905, 906, 907, 908, 909, 910,
911, 912, 913, 914, 915, 916,
917, 918, 919, 920, 921, 922,
923, 924, 925, 926, 927, 928,
929, 930, 931, 932, 933, 934,
935, 936, 937, 938, 939, 940,
941, 942, 943, 944, 945, 946,
947, 948, 949, 950, 951, 952,
953, 954, 955, 956, 957, 958,
959, 960, 961, 962, 963, 964,
965, 966, 967, 968, 969, 970,
971, 972, 973, 974, 975, 976,
977, 978, 979, 980, 981, 982,
983, 984, 985, 986, 987, 988,
989, 990, 991, 992, 993, 994,
995, 996, 997, 998, 999, 1000.

**ASSESSMENT
DIAGRAM**

NIPOMO MESA
SUPPLEMENTAL
ASSASSMENT DISTRICT
NO.1

NIPOMO COMMUNITY
SERVICES DISTRICT
STATE OF CALIFORNIA

Legend

- ASSM BOUNDARY
- ASSESSOR PARCEL
- DIAGRAM SHEET

1 inch = 200 Feet

**SHEET:
30 OF 59**

42



LOTS ON THIS SHEET ARE
BASED ON THE 2007 NIPOMO
MAP COUNTY OF SAN LUIS
OBISPO, CA; BK 080 PGS:
072, 078, 079, 081, 082, 083,
084, 085, 086, 087, 088, 089,
090, 091, 092, 093, 094, 095,
096, 097, 098, 099, 100, 101,
102, 103, 104, 105, 106, 107,
108, 109, 110, 111, 112, 113,
114, 115, 116, 117, 118, 119,
120, 121, 122, 123, 124, 125,
126, 127, 128, 129, 130, 131,
132, 133, 134, 135, 136, 137,
138, 139, 140, 141, 142, 143,
144, 145, 146, 147, 148, 149,
150, 151, 152, 153, 154, 155,
156, 157, 158, 159, 160, 161,
162, 163, 164, 165, 166, 167,
168, 169, 170, 171, 172, 173,
174, 175, 176, 177, 178, 179,
180, 181, 182, 183, 184, 185,
186, 187, 188, 189, 190, 191,
192, 193, 194, 195, 196, 197,
198, 199, 200, 201, 202, 203,
204, 205, 206, 207, 208, 209,
210, 211, 212, 213, 214, 215,
216, 217, 218, 219, 220, 221,
222, 223, 224, 225, 226, 227,
228, 229, 230, 231, 232, 233,
234, 235, 236, 237, 238, 239,
240, 241, 242, 243, 244, 245,
246, 247, 248, 249, 250, 251,
252, 253, 254, 255, 256, 257,
258, 259, 260, 261, 262, 263,
264, 265, 266, 267, 268, 269,
270, 271, 272, 273, 274, 275,
276, 277, 278, 279, 280, 281,
282, 283, 284, 285, 286, 287,
288, 289, 290, 291, 292, 293,
294, 295, 296, 297, 298, 299,
300, 301, 302, 303, 304, 305,
306, 307, 308, 309, 310, 311,
312, 313, 314, 315, 316, 317,
318, 319, 320, 321, 322, 323,
324, 325, 326, 327, 328, 329,
330, 331, 332, 333, 334, 335,
336, 337, 338, 339, 340, 341,
342, 343, 344, 345, 346, 347,
348, 349, 350, 351, 352, 353,
354, 355, 356, 357, 358, 359,
360, 361, 362, 363, 364, 365,
366, 367, 368, 369, 370, 371,
372, 373, 374, 375, 376, 377,
378, 379, 380, 381, 382, 383,
384, 385, 386, 387, 388, 389,
390, 391, 392, 393, 394, 395,
396, 397, 398, 399, 400, 401,
402, 403, 404, 405, 406, 407,
408, 409, 410, 411, 412, 413,
414, 415, 416, 417, 418, 419,
420, 421, 422, 423, 424, 425,
426, 427, 428, 429, 430, 431,
432, 433, 434, 435, 436, 437,
438, 439, 440, 441, 442,
443, 444, 445, 446, 447, 448,
449, 450, 451, 452, 453, 454,
455, 456, 457, 458, 459, 460,
461, 462, 463, 464, 465, 466,
467, 468, 469, 470, 471, 472,
473, 474, 475, 476, 477, 478,
479, 480, 481, 482, 483, 484,
485, 486, 487, 488, 489, 490,
491, 492, 493, 494, 495, 496,
497, 498, 499, 500, 501, 502,
503, 504, 505, 506, 507, 508,
509, 510, 511, 512, 513, 514,
515, 516, 517, 518, 519, 520,
521, 522, 523, 524, 525, 526,
527, 528, 529, 530, 531, 532,
533, 534, 535, 536, 537, 538,
539, 540, 541, 542, 543, 544,
545, 546, 547, 548, 549, 550,
551, 552, 553, 554, 555, 556,
557, 558, 559, 560, 561, 562,
563, 564, 565, 566, 567, 568,
569, 570, 571, 572, 573, 574,
575, 576, 577, 578, 579, 580,
581, 582, 583, 584, 585, 586,
587, 588, 589, 590, 591, 592,
593, 594, 595, 596, 597, 598,
599, 600, 601, 602, 603, 604,
605, 606, 607, 608, 609, 610,
611, 612, 613, 614, 615, 616,
617, 618, 619, 620, 621, 622,
623, 624, 625, 626, 627, 628,
629, 630, 631, 632, 633, 634,
635, 636, 637, 638, 639, 640,
641, 642, 643, 644, 645, 646,
647, 648, 649, 650, 651, 652,
653, 654, 655, 656, 657, 658,
659, 660, 661, 662, 663, 664,
665, 666, 667, 668, 669, 670,
671, 672, 673, 674, 675, 676,
677, 678, 679, 680, 681, 682,
683, 684, 685, 686, 687, 688,
689, 690, 691, 692, 693, 694,
695, 696, 697, 698, 699, 700,
701, 702, 703, 704, 705, 706,
707, 708, 709, 710, 711, 712,
713, 714, 715, 716, 717, 718,
719, 720, 721, 722, 723, 724,
725, 726, 727, 728, 729, 730,
731, 732, 733, 734, 735, 736,
737, 738, 739, 740, 741, 742,
743, 744, 745, 746, 747, 748,
749, 750, 751, 752, 753, 754,
755, 756, 757, 758, 759, 760,
761, 762, 763, 764, 765, 766,
767, 768, 769, 770, 771, 772,
773, 774, 775, 776, 777, 778,
779, 780, 781, 782, 783, 784,
785, 786, 787, 788, 789, 790,
791, 792, 793, 794, 795, 796,
797, 798, 799, 800, 801, 802,
803, 804, 805, 806, 807, 808,
809, 810, 811, 812, 813, 814,
815, 816, 817, 818, 819, 820,
821, 822, 823, 824, 825, 826,
827, 828, 829, 830, 831, 832,
833, 834, 835, 836, 837, 838,
839, 840, 841, 842, 843, 844,
845, 846, 847, 848, 849, 850,
851, 852, 853, 854, 855, 856,
857, 858, 859, 860, 861, 862,
863, 864, 865, 866, 867, 868,
869, 870, 871, 872, 873, 874,
875, 876, 877, 878, 879, 880,
881, 882, 883, 884, 885, 886,
887, 888, 889, 890, 891, 892,
893, 894, 895, 896, 897, 898,
899, 900, 901, 902, 903, 904,
905, 906, 907, 908, 909, 910,
911, 912, 913, 914, 915, 916,
917, 918, 919, 920, 921, 922,
923, 924, 925, 926, 927, 928,
929, 930, 931, 932, 933, 934,
935, 936, 937, 938, 939, 940,
941, 942, 943, 944, 945, 946,
947, 948, 949, 950, 951, 952,
953, 954, 955, 956, 957, 958,
959, 960, 961, 962, 963, 964,
965, 966, 967, 968, 969, 970,
971, 972, 973, 974, 975, 976,
977, 978, 979, 980, 981, 982,
983, 984, 985, 986, 987, 988,
989, 990, 991, 992, 993, 994,
995, 996, 997, 998, 999, 1000

27

33

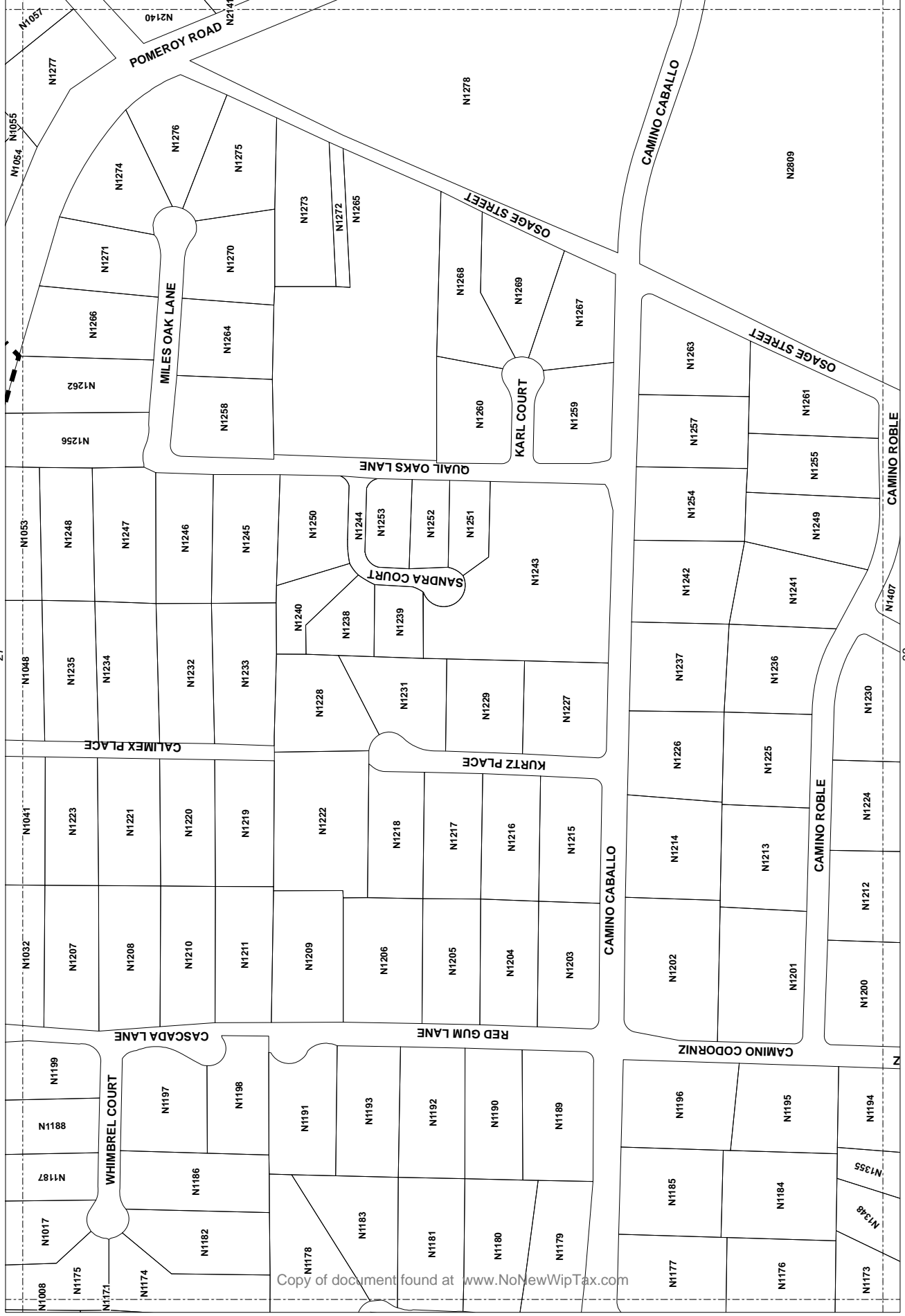

26

29



32

ASSESSMENT DIAGRAM

NIPOMO MESA
SUPPLEMENTAL
ASSESSMENT DISTRICT
NO.1

NIPOMO COMMUNITY
SERVICES DISTRICT
STATE OF CALIFORNIA

Legend

-  ASSESSMENT BOUNDARY
-  ASSESSOR PARCEL
-  DIAGRAM SHEET

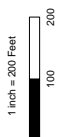

SHEET:
31 OF 59



LOTS ON THIS SHEET ARE
EASEMENTS FOR THE
MAP COUNTY OF SAN LUIS
OBISPO, CA; BK 080 PGS:
072, 078, 079, 081, 082, 083,
084, 085, 086, 087, 088,
089, 090, 102, 103, 111, 121,
122, 123, 131, 132, 133, 134,
135, 140, 141, 142, 143, 144,
145, 146, 147, 148, 149, 150,
151, 152, 153, 154, 155,
156, 157, 158, 159, 160, 161,
162, 163, 164, 165, 166, 167,
168, 169, 170, 171, 172, 173,
174, 175, 176, 177, 178, 179,
180, 181, 182, 183, 184, 185,
186, 187, 188, 189, 190, 191,
192, 193, 194, 195, 196, 197,
198, 199, 200, 201, 202, 203,
204, 205, 206, 207, 208, 209,
210, 211, 212, 213, 214, 215,
216, 217, 218, 219, 220, 221,
222, 223, 243, 244, 246, 247,
248, 249, 250, 251, 252, 253,
254, 255, 256, 257, 258, 259,
260, 261, 262, 263, 264, 265,
266, 267, 268, 269, 270, 271,
272, 273, 274, 275, 276, 277,
278, 279, 280, 281, 282, 283,
284, 285, 286, 287, 288, 289,
290, 291, 292, 293, 294, 295,
296, 297, 298, 299, 300, 301,
302, 303, 304, 305, 306, 307,
308, 309, 310, 311, 312, 313,
314, 315, 316, 317, 318, 319,
320, 321, 322, 323, 324, 325,
326, 327, 328, 329, 330, 331,
332, 333, 334, 335, 336, 337,
338, 339, 340, 341, 342, 343,
344, 345, 346, 347, 348, 349,
350, 351, 352, 353, 354, 355,
356, 357, 358, 359, 360, 361,
362, 363, 364, 365, 366, 367,
368, 369, 370, 371, 372, 373,
374, 375, 376, 381, 382, 410, 411,
412, 413, 414, 415, 416, 417,
418, 419, 420, 421, 422, 423,
424, 425, 426, 427, 428, 429,
430, 431, 440, 441, 442,
443, 444, 445, 446,
BK 091 PGS: 011, 053, 054, 055,
056, 057, 058, 059, 060, 061,
062, 063, 064, 065, 066, 067,
068, 069, 070, 071, 072, 073,
074, 075, 076, 077, 078, 079,
080, 081, 082, 083,
129, 130, 136, 137, 138, 139,
141, 142, 143, 144, 145, 146,
147, 148, 149, 150, 152, 153,
154, 155, 156, 157, 158, 159,
161, 251, 252, 281, 282, 283,
284, 285, 286, 287, 288, 289,
302, 303, 304, 311, 321, 331, 341,
351, 352, 353, 354, 355, 356,
365, 366, 463, 510, 512, 513,
514, 515, 516, 517, 518, 519,
521, 522, 523, 533, 534, 551, 570,
571, 572, 573, 574, 575, 576,
577.

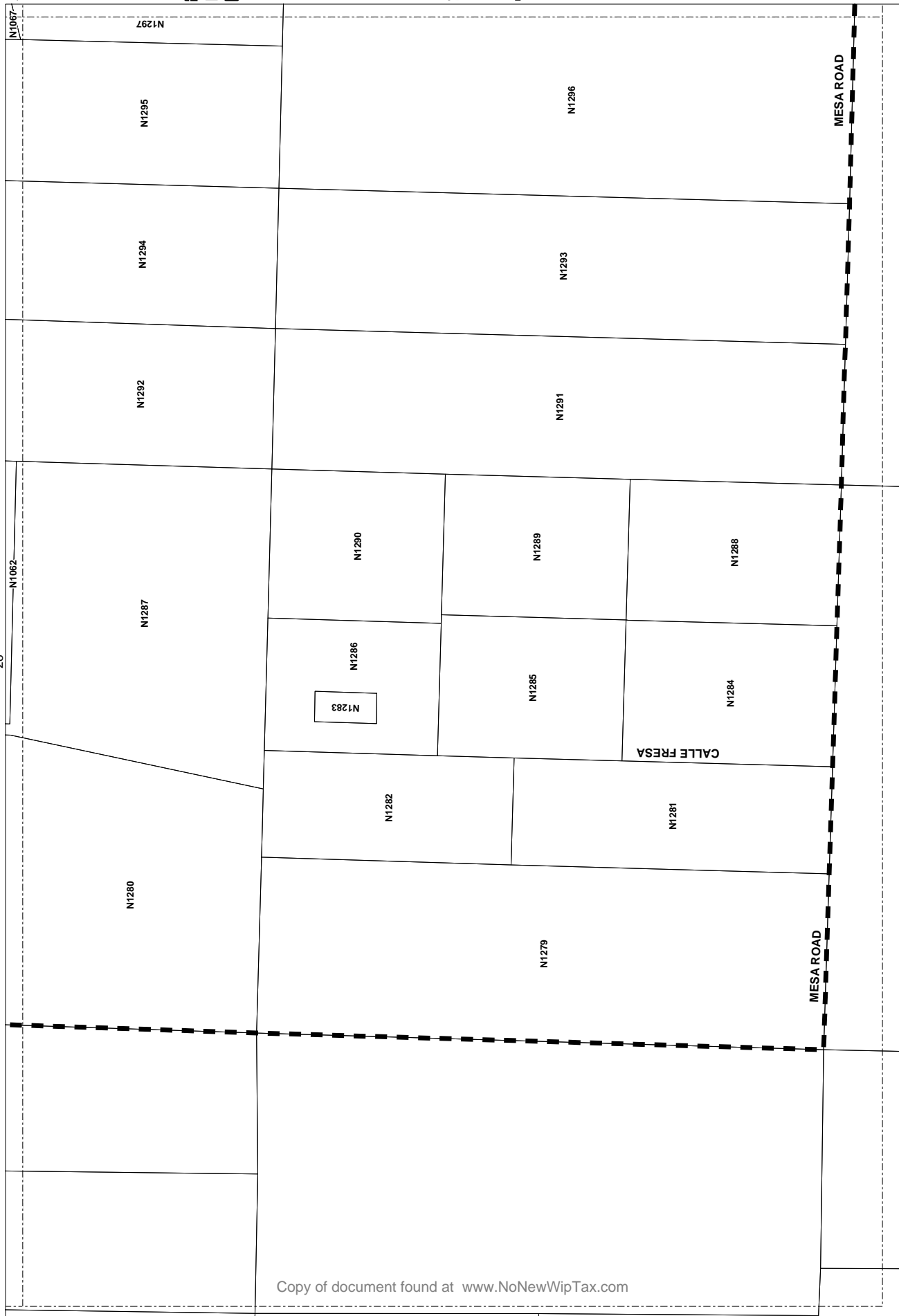



**ASSESSMENT
DIAGRAM**

NIPOMO MESA
SUPPLEMENTAL
ASSESSMENT DISTRICT
NO. 1

NIPOMO COMMUNITY
SERVICES DISTRICT
STATE OF CALIFORNIA

Legend

-  ASSM BOUNDARY
-  ASSESSOR PARCEL
-  DIAGRAM SHEET

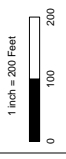

**SHEET:
32 OF 59**



LOTS ON THIS SHEET ARE
BASED UPON THE 2017
MAP COUNTY OF SAN LUIS
OBISPO, CA; BK 080 PGS:
072, 078, 079, 081, 082, 083,
084, 085, 086, 087, 088, 089,
095, 101, 102, 103, 111, 121,
122, 123, 131, 132, 133, 134,
135, 141, 142, 143, 144,
151, 152, 161, 162, 163, 164,
307, 361, 362, 363, 364, 371,
372, 381, 382, 383, 384, 385,
391, 401, 402, 403, 404, 405,
BK 081 PGS: 011, 053, 054,
063, 073, 081, 081, 121, 131,
202, 233, 243, 244, 246, 247,
248, 249, 250, 251, 252, 253,
257, 311, 313, 320, 325, 326,
327, 328, 371, 372, 373, 374,
375, 376, 381, 382, 410, 411,
412, 413, 414, 415, 416, 417,
421, 430, 431, 440, 441, 442,
443, 444, 445, 446,
BK 092 PGS: 081, 082, 083,
111, 112, 113, 114, 115, 116,
120, 130, 136, 137, 138, 139,
141, 142, 143, 144, 145, 146,
147, 148, 149, 150, 152, 153,
154, 155, 156, 157, 158, 159,
281, 282, 283, 284, 285, 286,
271, 272, 282, 283, 291, 302,
303, 304, 311, 321, 331, 341,
351, 361, 371, 381, 391, 401,
395, 460, 463, 510, 512, 513,
531, 532, 533, 534, 551, 570,
571, 572, 573, 574, 575, 576,
577.

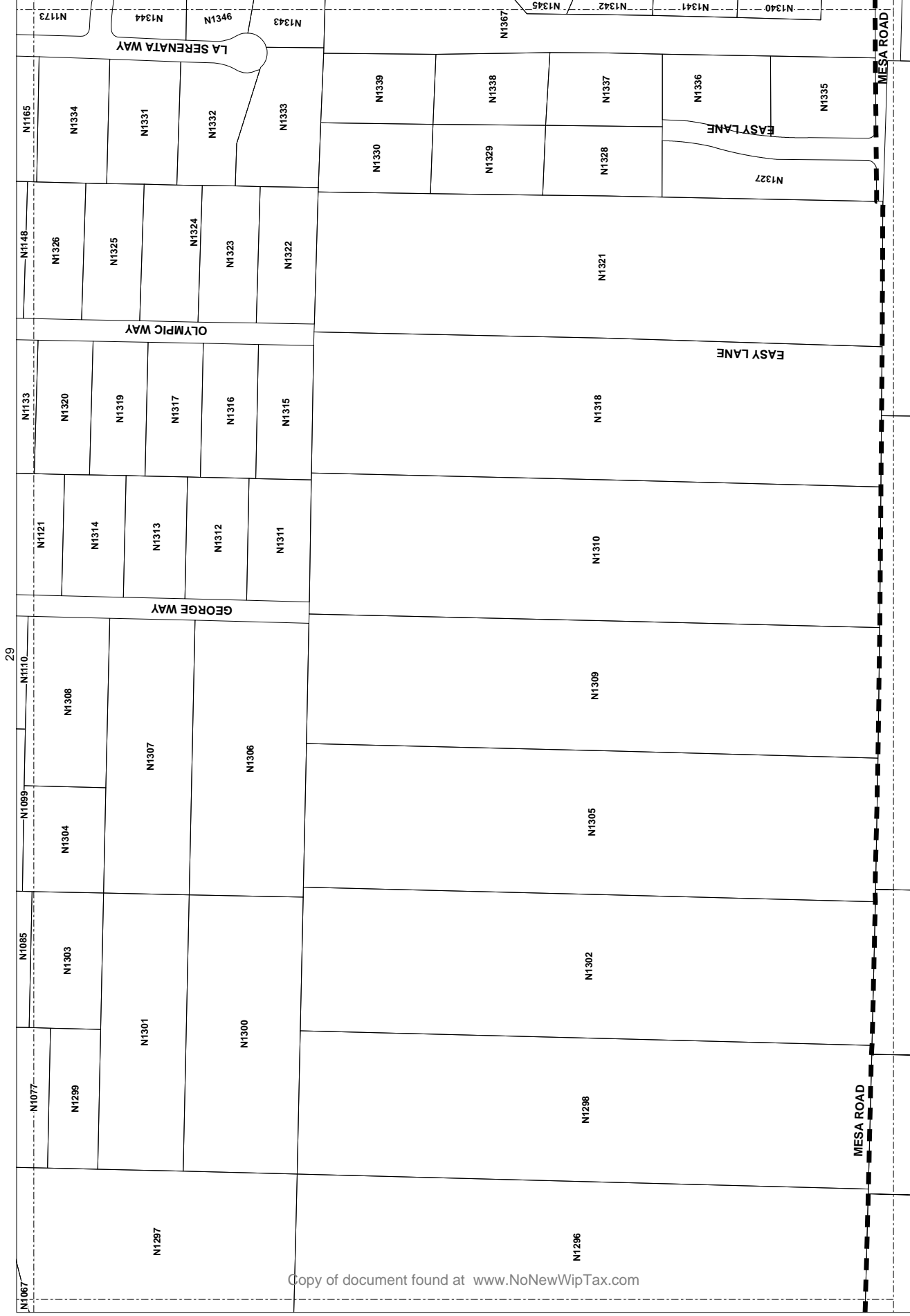



**ASSESSMENT
DIAGRAM**

NIPOMO MESA
SUPPLEMENTAL
ASSESSMENT DISTRICT
NO.1

NIPOMO COMMUNITY
SERVICES DISTRICT
STATE OF CALIFORNIA

Legend

-  ASSESSMENT BOUNDARY
-  ASSESSOR PARCEL
-  DIAGRAM SHEET

35

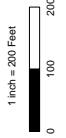

**SHEET:
34 OF 59**

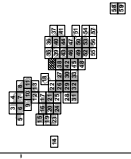

LOTS ON THIS SHEET ARE
EASELMENTS TO THE
MAP COUNTY OF SAN LUIS
OBISPO, CA; BK 080 PGS:
072, 078, 079, 081, 082, 083,
084, 085, 086, 087, 088,
089, 090, 102, 103, 111, 121,
122, 123, 131, 132, 133, 134,
135, 146, 147, 148, 149, 150,
151, 152, 153, 154, 155,
156, 157, 161, 162, 163, 164,
165, 166, 167, 168, 169, 170,
171, 172, 173, 174, 175,
176, 177, 178, 179, 180, 181,
182, 183, 184, 185, 186,
187, 188, 189, 190, 191, 192,
193, 194, 195, 196, 197,
198, 199, 200, 201, 202,
203, 204, 205, 206, 207,
208, 209, 210, 211, 212,
213, 214, 215, 216, 217,
218, 219, 220, 221, 222,
223, 224, 225, 226, 227,
228, 229, 230, 231, 232,
233, 234, 235, 236, 237,
238, 239, 240, 241, 242,
243, 244, 245, 246, 247,
248, 249, 250, 251, 252,
253, 254, 255, 256, 257,
258, 259, 260, 261, 262,
263, 264, 265, 266, 267,
268, 269, 270, 271, 272,
273, 274, 275, 276, 277,
278, 279, 280, 281, 282,
283, 284, 285, 286, 287,
288, 289, 290, 291, 292,
293, 294, 295, 296, 297,
298, 299, 300, 301, 302,
303, 304, 305, 306, 307,
308, 309, 310, 311, 312,
313, 314, 315, 316, 317,
318, 319, 320, 321, 322,
323, 324, 325, 326, 327,
328, 329, 330, 331, 332,
333, 334, 335, 336, 337,
338, 339, 340, 341, 342,
343, 344, 345, 346, 347,
348, 349, 350, 351, 352,
353, 354, 355, 356, 357,
358, 359, 360, 361, 362,
363, 364, 365, 366, 367,
368, 369, 370, 371, 372,
373, 374, 375, 376, 377,
378, 379, 380, 381, 382,
383, 384, 385, 386,
387, 388, 389, 390, 391,
392, 393, 394, 395, 396,
397, 398, 399, 400, 401,
402, 403, 404, 405, 406,
407, 408, 409, 410, 411,
412, 413, 414, 415, 416,
417, 418, 419, 420, 421,
422, 423, 424, 425, 426,
427, 428, 429, 430, 431,
432, 433, 434, 435, 436,
437, 438, 439, 440, 441,
442, 443, 444, 445, 446,
447, 448, 449, 450, 451,
452, 453, 454, 455, 456,
457, 458, 459, 460, 461,
462, 463, 464, 465, 466,
467, 468, 469, 470, 471,
472, 473, 474, 475, 476,
477, 478, 479, 480, 481,
482, 483, 484, 485, 486,
487, 488, 489, 490, 491,
492, 493, 494, 495, 496,
497, 498, 499, 500, 501,
502, 503, 504, 505, 506,
507, 508, 509, 510, 511,
512, 513, 514, 515, 516,
517, 518, 519, 520, 521,
522, 523, 524, 525, 526,
527, 528, 529, 530, 531,
532, 533, 534, 535, 536,
537, 538, 539, 540, 541,
542, 543, 544, 545, 546,
547, 548, 549, 550, 551,
552, 553, 554, 555, 556,
557, 558, 559, 560, 561,
562, 563, 564, 565, 566,
567, 568, 569, 570, 571,
572, 573, 574, 575, 576,
577.

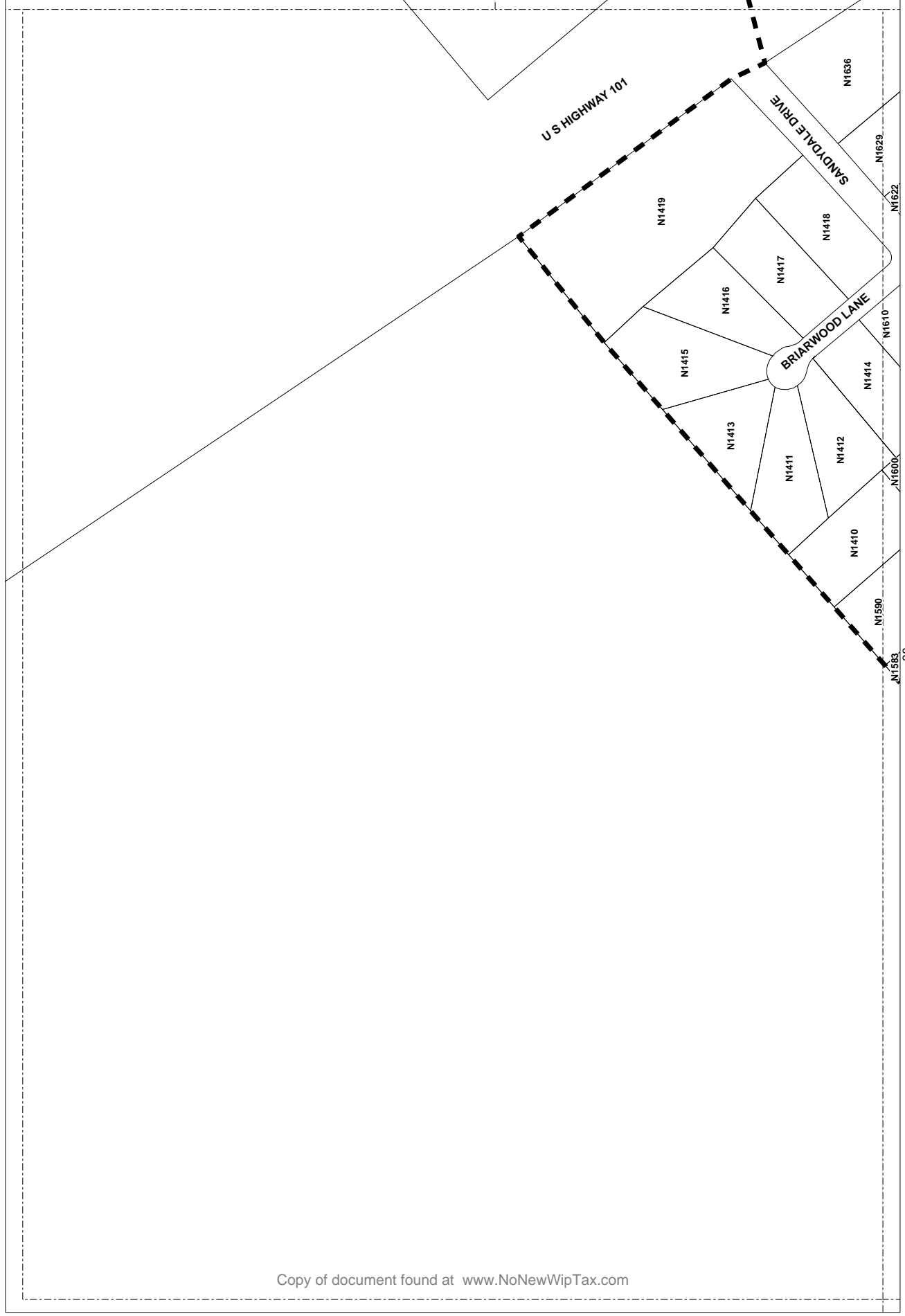





**ASSESSMENT
DIAGRAM**

NIPOMO MESA
SUPPLEMENTAL
ASSASSMENT DISTRICT
NO.1

NIPOMO COMMUNITY
SERVICES DISTRICT
STATE OF CALIFORNIA

Legend

-  ASSESSOR PARCEL
-  ASSESSOR PARCEL
-  ASSESSOR PARCEL



1 inch = 200 Feet

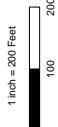

**SHEET:
35 OF 59**

36

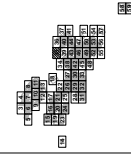

LOTS ON THIS SHEET ARE
EAST OF THOMPSON AVENUE
MAP COUNTY OF SAN LUIS
OBISPO, CA; BK 080 PGS:
072, 078, 079, 081, 082, 083,
084, 085, 086, 087, 088, 089,
090, 091, 092, 093, 094, 095,
096, 097, 098, 099, 100, 101,
102, 103, 104, 105, 106, 107,
108, 109, 110, 111, 112, 113,
114, 115, 116, 117, 118, 119,
120, 121, 122, 123, 124, 125,
126, 127, 128, 129, 130, 131,
132, 133, 134, 135, 136, 137,
138, 139, 140, 141, 142, 143,
144, 145, 146, 147, 148, 149,
150, 151, 152, 153, 154, 155,
156, 157, 158, 159, 160, 161,
162, 163, 164, 165, 166, 167,
168, 169, 170, 171, 172, 173,
174, 175, 176, 177, 178, 179,
180, 181, 182, 183, 184, 185,
186, 187, 188, 189, 190, 191,
192, 193, 194, 195, 196, 197,
198, 199, 200, 201, 202, 203,
204, 205, 206, 207, 208, 209,
210, 211, 212, 213, 214, 215,
216, 217, 218, 219, 220, 221,
222, 223, 224, 225, 226, 227,
228, 229, 230, 231, 232, 233,
234, 235, 236, 237, 238, 239,
240, 241, 242, 243, 244, 245,
246, 247, 248, 249, 250, 251,
252, 253, 254, 255, 256, 257,
258, 259, 260, 261, 262, 263,
264, 265, 266, 267, 268, 269,
270, 271, 272, 273, 274, 275,
276, 277, 278, 279, 280, 281,
282, 283, 284, 285, 286, 287,
288, 289, 290, 291, 292, 293,
294, 295, 296, 297, 298, 299,
300, 301, 302, 303, 304, 305,
306, 307, 308, 309, 310, 311,
312, 313, 314, 315, 316, 317,
318, 319, 320, 321, 322, 323,
324, 325, 326, 327, 328, 329,
330, 331, 332, 333, 334, 335,
336, 337, 338, 339, 340, 341,
342, 343, 344, 345, 346, 347,
348, 349, 350, 351, 352, 353,
354, 355, 356, 357, 358, 359,
360, 361, 362, 363, 364, 365,
366, 367, 368, 369, 370, 371,
372, 373, 374, 375, 376, 377,
378, 379, 380, 381, 382, 383,
384, 385, 386, 387, 388, 389,
390, 391, 392, 393, 394, 395,
396, 397, 398, 399, 400, 401,
402, 403, 404, 405, 406, 407,
408, 409, 410, 411, 412, 413,
414, 415, 416, 417, 418, 419,
420, 421, 422, 423, 424, 425,
426, 427, 428, 429, 430, 431,
432, 433, 434, 435, 436, 437,
438, 439, 440, 441, 442, 443,
444, 445, 446, 447, 448, 449,
450, 451, 452, 453, 454, 455,
456, 457, 458, 459, 460, 461,
462, 463, 464, 465, 466, 467,
468, 469, 470, 471, 472, 473,
474, 475, 476, 477, 478, 479,
480, 481, 482, 483, 484, 485,
486, 487, 488, 489, 490, 491,
492, 493, 494, 495, 496, 497,
498, 499, 500, 501, 502, 503,
504, 505, 506, 507, 508, 509,
510, 511, 512, 513, 514, 515,
516, 517, 518, 519, 520, 521,
522, 523, 524, 525, 526, 527,
528, 529, 530, 531, 532, 533,
534, 535, 536, 537, 538, 539,
540, 541, 542, 543, 544, 545,
546, 547, 548, 549, 550, 551,
552, 553, 554, 555, 556, 557,
558, 559, 560, 561, 562, 563,
564, 565, 566, 567, 568, 569,
570, 571, 572, 573, 574, 575, 576,
577.

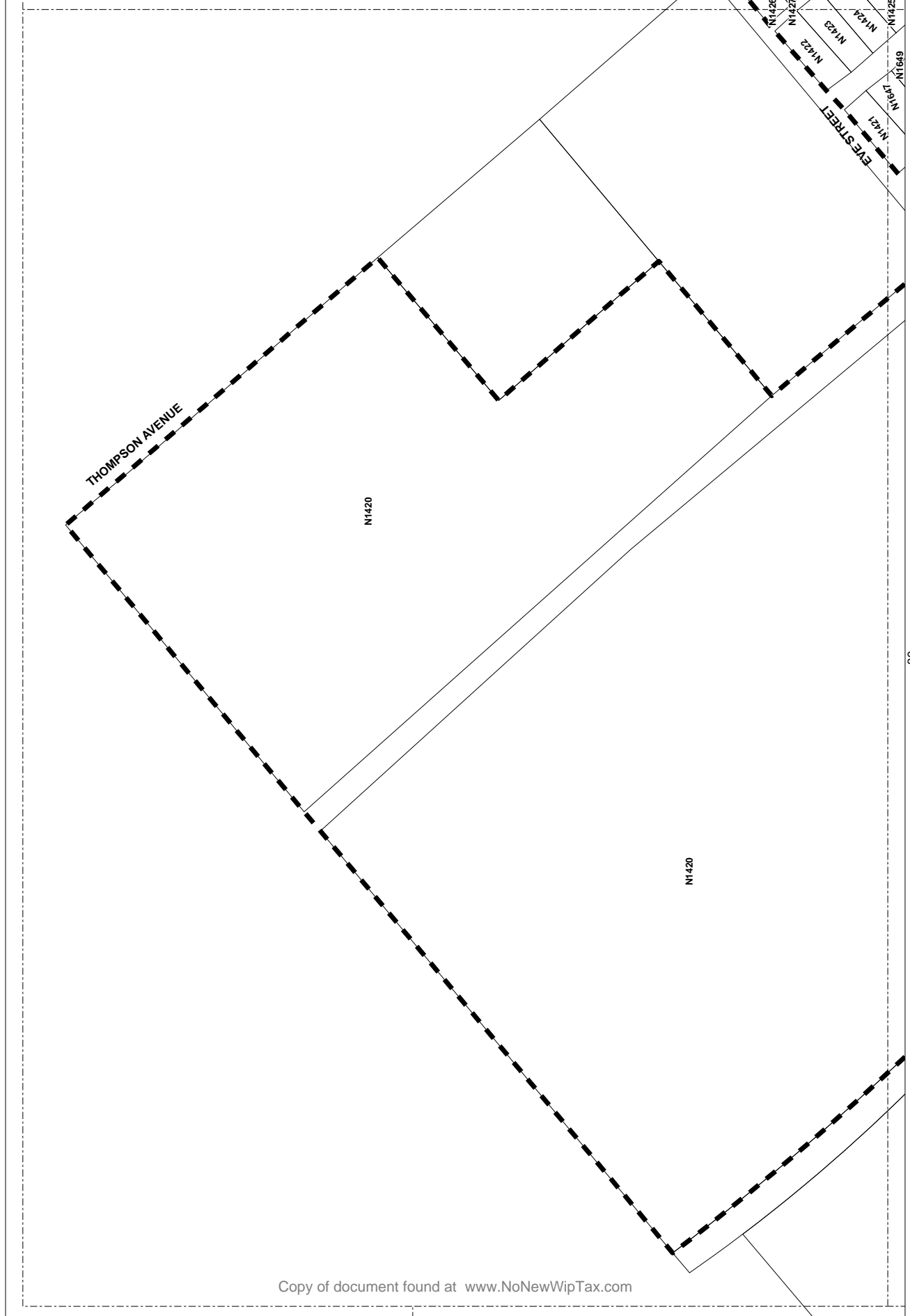



ASSESSMENT DIAGRAM

NIPOMO MESA
SUPPLEMENTAL
ASSASSMENT DISTRICT
NO.1

NIPOMO COMMUNITY
SERVICES DISTRICT
STATE OF CALIFORNIA

Legend

-  ASSESSMENT BOUNDARY
-  ASSESSOR PARCEL
-  DIAGRAM SHEET

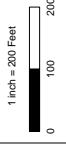

SHEET:
37 OF 59

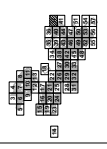

LOTS ON THIS SHEET ARE
EASEMENTS FOR THE
MAP COUNTY OF SAN LUIS
OBISPO, CA; BK 080 PGS:
072, 078, 079, 081, 082, 083,
084, 085, 086, 087, 088,
089, 090, 102, 103, 111, 121,
122, 123, 131, 132, 133, 134,
135, 136, 141, 142, 143, 144,
145, 146, 147, 148, 149, 150,
151, 152, 153, 154, 155,
156, 157, 158, 159, 160, 161,
162, 163, 164, 165, 166, 167,
168, 169, 170, 171, 172, 173,
174, 175, 176, 177, 178, 179,
180, 181, 182, 183, 184, 185,
186, 187, 188, 189, 190, 191,
192, 193, 194, 195, 196, 197,
198, 199, 200, 201, 202, 203,
204, 205, 206, 207, 208, 209,
210, 211, 212, 213, 214, 215,
216, 217, 218, 219, 220, 221,
222, 223, 243, 244, 246, 247,
248, 249, 250, 251, 252, 253,
254, 255, 256, 257, 258,
259, 260, 261, 262, 263, 264,
265, 266, 267, 268, 269, 270,
271, 272, 282, 283, 284, 285,
286, 287, 288, 289, 290, 291,
292, 293, 294, 295, 296, 297,
298, 299, 300, 301, 302, 303,
304, 305, 306, 307, 308, 309,
310, 311, 312, 313, 314, 315,
316, 317, 318, 319, 320, 321,
322, 323, 324, 325, 326, 327,
328, 329, 330, 331, 332, 333,
334, 335, 336, 337, 338, 339,
340, 341, 342, 343, 344, 345,
346, 347, 348, 349, 350, 351,
352, 353, 354, 355, 356, 357,
358, 359, 360, 361, 362, 363,
364, 365, 366, 367, 368, 369,
370, 371, 372, 373, 374, 375,
376, 377, 378, 379, 380, 381,
382, 383, 384, 385, 386, 387,
388, 389, 390, 391, 392, 393,
394, 395, 396, 397, 398, 399,
400, 401, 402, 403, 404, 405,
406, 407, 408, 409, 410, 411,
412, 413, 414, 415, 416, 417,
418, 419, 420, 421, 422, 423,
424, 425, 426, 427, 428, 429,
430, 431, 432, 433, 434, 435,
436, 437, 438, 439, 440, 441,
442, 443, 444, 445, 446,
447, 448, 449, 450, 451, 452,
453, 454, 455, 456, 457, 458,
459, 460, 461, 462, 463, 464,
465, 466, 467, 468, 469, 470,
471, 472, 473, 474, 475, 476,
477, 478, 479, 480, 481, 482,
483, 484, 485, 486, 487, 488,
489, 490, 491, 492, 493, 494,
495, 496, 497, 498, 499, 500,
501, 502, 503, 504, 505, 506,
507, 508, 509, 510, 511, 512,
513, 514, 515, 516, 517, 518,
519, 520, 521, 522, 523, 524,
525, 526, 527, 528, 529, 530,
531, 532, 533, 534, 535, 536,
537, 538, 539, 540, 541, 542,
543, 544, 545, 546, 547, 548,
549, 550, 551, 552, 553, 554,
555, 556, 557, 558, 559, 560,
561, 562, 563, 564, 565, 566,
567, 568, 569, 570, 571, 572,
573, 574, 575, 576, 577.

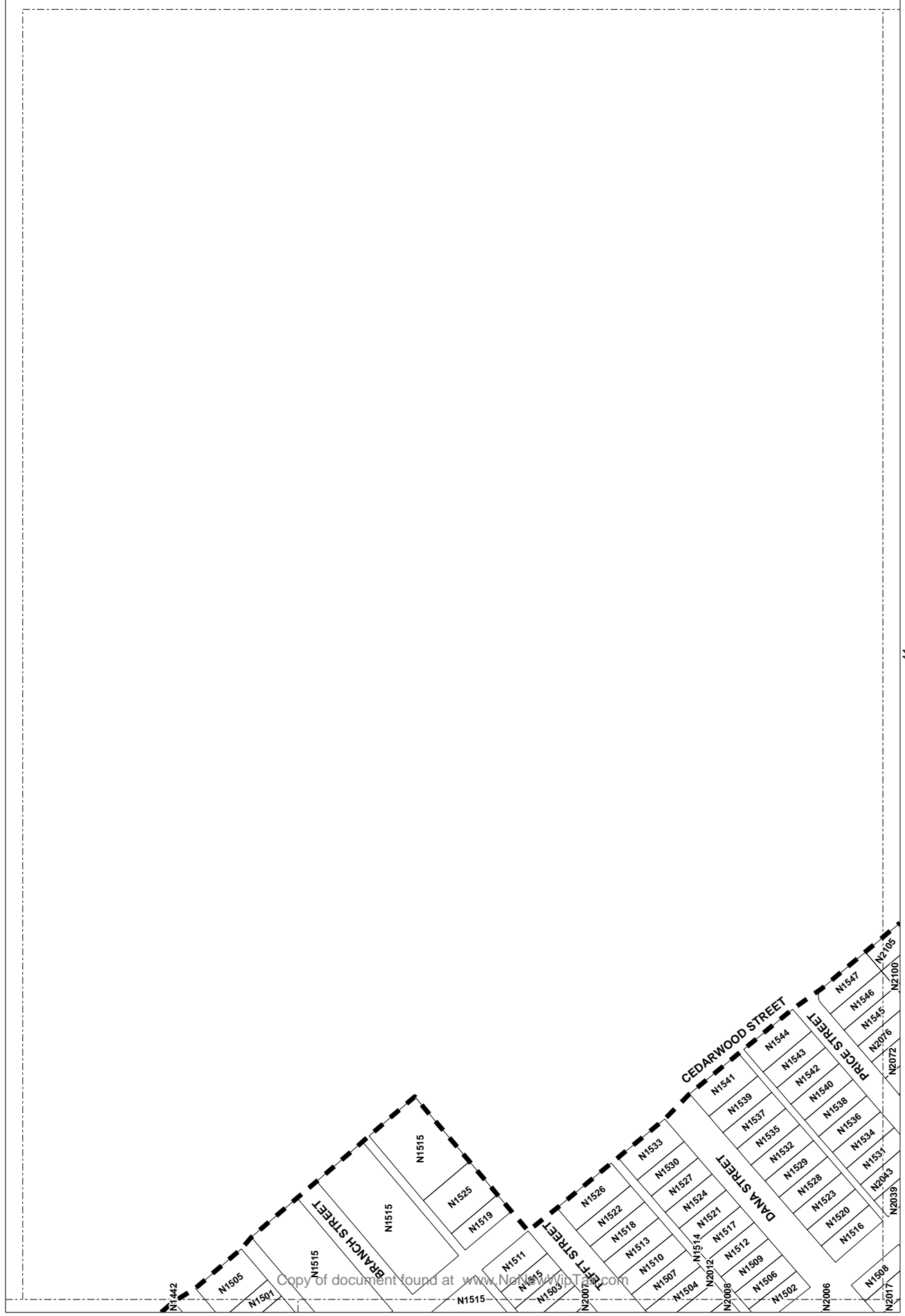

Copy of document found at www.Nipomamaps.com

**ASSESSMENT
DIAGRAM**

NIPOMO MESA
SUPPLEMENTAL
ASSESSMENT DISTRICT
NO. 1
NIPOMO COMMUNITY
SERVICES DISTRICT
STATE OF CALIFORNIA

Legend

- ASSM BOUNDARY
- ASSESSOR PARCEL
- DIAGRAM SHEET



1 inch = 200 Feet
0 100 200

**SHEET:
38 OF 59**



LOTS ON THIS SHEET ARE
NOT TO BE USED FOR
MAP COUNTY OF SAN LUIS
OBISPO, CA; BK 080 PGS:
072, 078, 079, 081, 082, 083,
084, 085, 086, 087, 088, 089,
090, 091, 092, 093, 094,
095, 101, 102, 103, 111, 121,
122, 123, 131, 132, 133, 134,
135, 141, 142, 143, 144,
151, 152, 161, 162, 163, 164,
165, 171, 172, 173, 181,
182, 183, 184, 185, 191,
192, 201, 202, 203, 204, 205,
211, 212, 213, 214, 215, 221,
222, 223, 224, 225, 226, 227,
228, 229, 231, 232, 233,
234, 235, 236, 237, 238, 239,
241, 242, 243, 244, 245, 251,
252, 253, 254, 255, 256, 257,
258, 259, 261, 262, 263, 264,
265, 266, 267, 268, 269, 271,
272, 273, 274, 275, 276, 277,
278, 279, 281, 282, 283, 284,
285, 291, 292, 293, 294, 295,
296, 297, 298, 299, 301, 302,
303, 304, 311, 312, 313, 314,
315, 321, 322, 323, 324, 325,
326, 327, 328, 329, 331, 332,
333, 334, 335, 341, 342, 343,
344, 345, 351, 352, 353, 354, 355,
356, 357, 358, 359, 361, 362,
363, 364, 365, 366, 367, 368,
369, 371, 372, 373, 374, 375,
376, 377, 378, 379, 381, 382,
383, 384, 385, 386, 387, 388,
389, 391, 392, 393, 394, 395,
396, 397, 398, 399, 401, 402,
403, 404, 405, 411, 412, 413,
414, 415, 421, 422, 423, 424,
425, 431, 432, 433, 434, 435,
436, 437, 438, 439, 441, 442,
443, 444, 445, 446, 451, 452,
453, 454, 455, 461, 462, 463,
464, 465, 466, 467, 468, 469,
471, 472, 473, 474, 475, 476,
477, 478, 479, 481, 482, 483,
484, 485, 486, 487, 488, 489,
491, 492, 493, 494, 495, 496,
497, 498, 499, 501, 502, 503,
504, 505, 506, 507, 508, 509,
511, 512, 513, 514, 515, 516,
517, 518, 519, 521, 522, 523,
524, 525, 526, 527, 528, 529,
531, 532, 533, 534, 535, 536,
537, 538, 539, 541, 542, 543,
544, 545, 546, 547, 548, 549,
551, 552, 553, 554, 555, 556,
557, 558, 559, 561, 562, 563,
564, 565, 566, 567, 568, 569,
571, 572, 573, 574, 575, 576,
577.

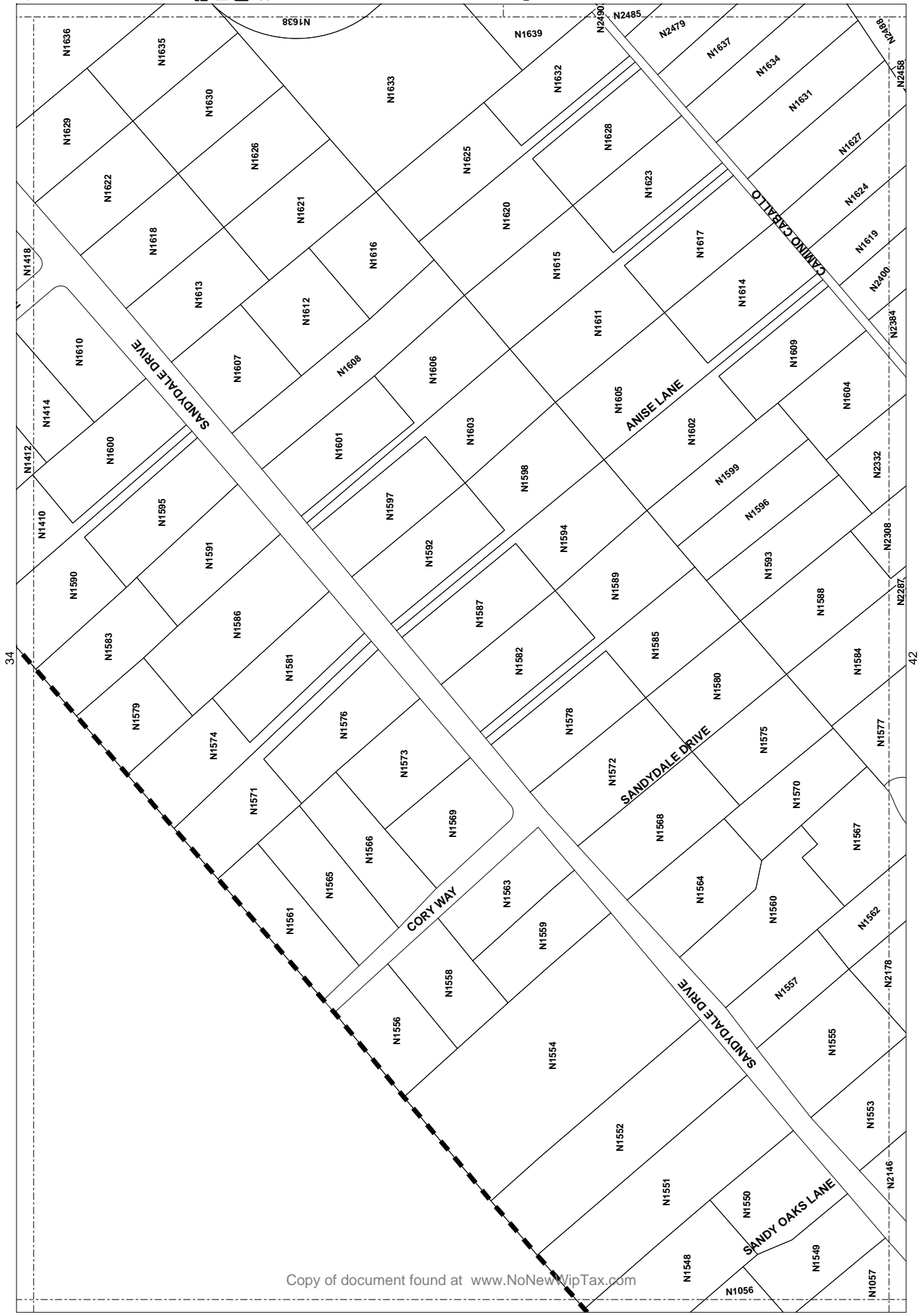





**ASSESSMENT
DIAGRAM**

NIPOMO MESA
SUPPLEMENTAL
ASSESSMENT DISTRICT
NO. 1

NIPOMO COMMUNITY
SERVICES DISTRICT
STATE OF CALIFORNIA

Legend

-  ASSESSMENT BOUNDARY
-  ASSESSOR PARCEL
-  DIAGRAM SHEET



1 inch = 200 Feet

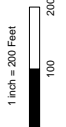

**SHEET:
39 OF 59**



LOTS ON THIS SHEET ARE
EXTRACTED FROM THE
MAP COUNTY OF SAN LUIS
OBISPO, CA; BK 080 PGS:
072, 078, 079, 081, 082, 083,
084, 085, 086, 087, 088, 089,
090, 091, 092, 093, 094, 095,
096, 097, 098, 099, 100, 101,
102, 103, 104, 105, 106, 107,
108, 109, 110, 111, 112, 113,
114, 115, 116, 117, 118, 119,
120, 121, 122, 123, 124, 125,
126, 127, 128, 129, 130, 131,
132, 133, 134, 135, 136, 137,
138, 139, 140, 141, 142, 143,
144, 145, 146, 147, 148, 149,
150, 151, 152, 153, 154, 155,
156, 157, 158, 159, 160, 161,
162, 163, 164, 165, 166, 167,
168, 169, 170, 171, 172, 173,
174, 175, 176, 177, 178, 179,
180, 181, 182, 183, 184, 185,
186, 187, 188, 189, 190, 191,
192, 193, 194, 195, 196, 197,
198, 199, 200, 201, 202, 203,
204, 205, 206, 207, 208, 209,
210, 211, 212, 213, 214, 215,
216, 217, 218, 219, 220, 221,
222, 223, 224, 225, 226, 227,
228, 229, 230, 231, 232, 233,
234, 235, 236, 237, 238, 239,
240, 241, 242, 243, 244, 245,
246, 247, 248, 249, 250, 251,
252, 253, 254, 255, 256, 257,
258, 259, 260, 261, 262, 263,
264, 265, 266, 267, 268, 269,
270, 271, 272, 273, 274, 275,
276, 277, 278, 279, 280, 281,
282, 283, 284, 285, 286, 287,
288, 289, 290, 291, 292, 293,
294, 295, 296, 297, 298, 299,
300, 301, 302, 303, 304, 305,
306, 307, 308, 309, 310, 311,
312, 313, 314, 315, 316, 317,
318, 319, 320, 321, 322, 323,
324, 325, 326, 327, 328, 329,
330, 331, 332, 333, 334, 335,
336, 337, 338, 339, 340, 341,
342, 343, 344, 345, 346, 347,
348, 349, 350, 351, 352, 353,
354, 355, 356, 357, 358, 359,
360, 361, 362, 363, 364, 365,
366, 367, 368, 369, 370, 371,
372, 373, 374, 375, 376, 377,
378, 379, 380, 381, 382, 383,
384, 385, 386, 387, 388, 389,
390, 391, 392, 393, 394, 395,
396, 397, 398, 399, 400, 401,
402, 403, 404, 405, 406, 407,
408, 409, 410, 411, 412, 413,
414, 415, 416, 417, 418, 419,
420, 421, 422, 423, 424, 425,
426, 427, 428, 429, 430, 431,
432, 433, 434, 435, 436, 437,
438, 439, 440, 441, 442, 443,
444, 445, 446, 447, 448, 449,
450, 451, 452, 453, 454, 455,
456, 457, 458, 459, 460, 461,
462, 463, 464, 465, 466, 467,
468, 469, 470, 471, 472, 473,
474, 475, 476, 477, 478, 479,
480, 481, 482, 483, 484, 485,
486, 487, 488, 489, 490, 491,
492, 493, 494, 495, 496, 497,
498, 499, 500, 501, 502, 503,
504, 505, 506, 507, 508, 509,
510, 511, 512, 513, 514, 515,
516, 517, 518, 519, 520, 521,
522, 523, 524, 525, 526, 527,
528, 529, 530, 531, 532, 533,
534, 535, 536, 537, 538, 539,
540, 541, 542, 543, 544, 545,
546, 547, 548, 549, 550, 551,
552, 553, 554, 555, 556, 557,
558, 559, 560, 561, 562, 563,
564, 565, 566, 567, 568, 569,
570, 571, 572, 573, 574, 575, 576,
577.

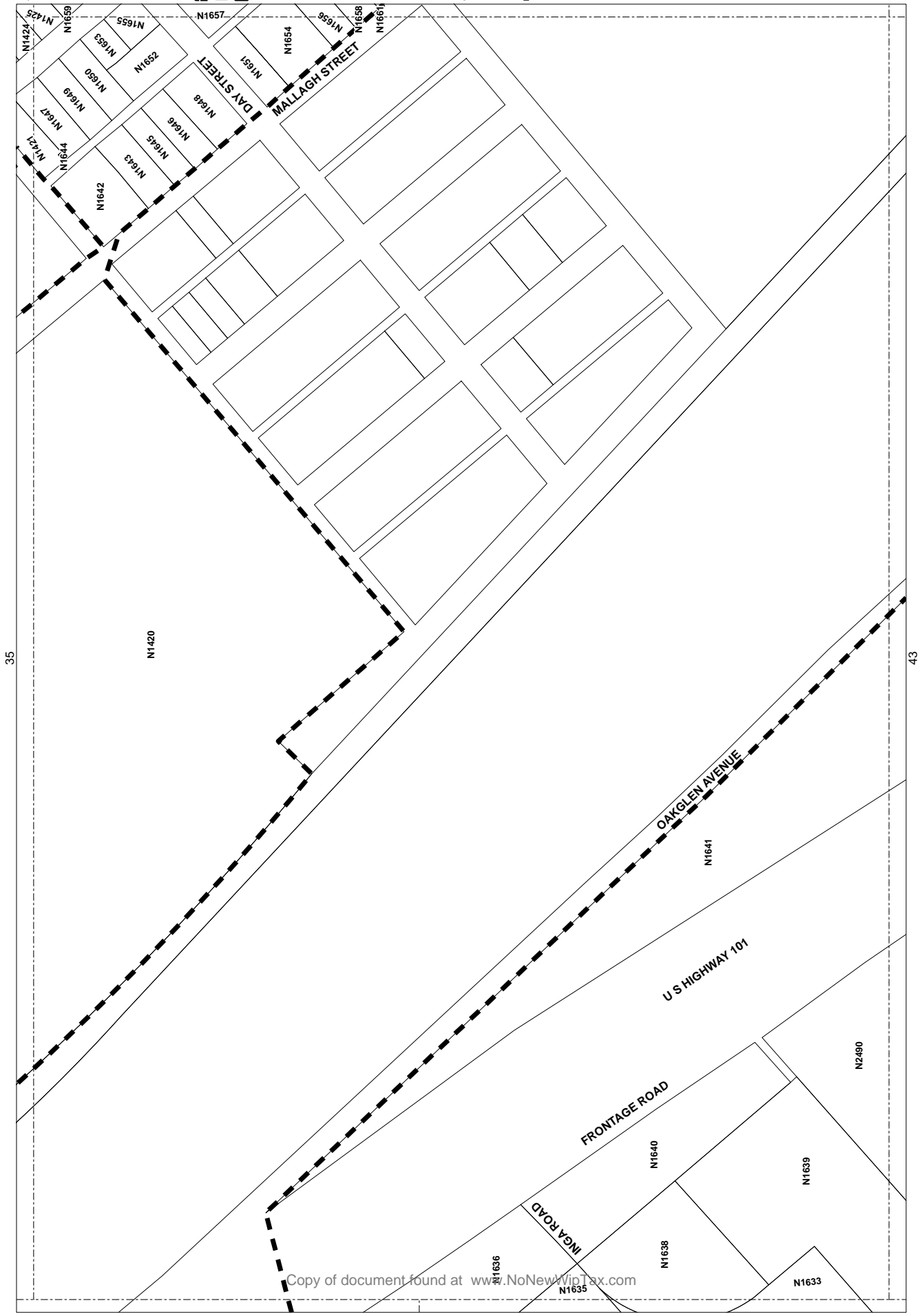

**ASSESSMENT
DIAGRAM**

NIPOMO MESA
SUPPLEMENTAL
ASSESSMENT DISTRICT
NO. 1

NIPOMO COMMUNITY
SERVICES DISTRICT
STATE OF CALIFORNIA

- Legend**
- ASSM BOUNDARY
 - ASSESSOR PARCEL
 - DIAGRAM SHEET

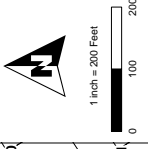

**SHEET:
42 OF 59**

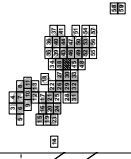

LOTS ON THIS SHEET ARE
FROM THE NIPOMO MESA
MAP COUNTY OF SAN LUIS
OBISPO, CA; BK 080 PGS:
072, 078, 079, 081, 082, 083,
084, 085, 086, 087, 088, 089,
090, 091, 092, 093, 111, 121,
122, 123, 131, 132, 133, 134,
135, 136, 141, 142, 143, 144,
145, 146, 147, 148, 149, 150,
151, 152, 153, 154, 155, 156,
157, 158, 159, 160, 161, 162,
163, 164, 165, 166, 167, 168,
169, 170, 171, 172, 173, 174,
175, 176, 177, 178, 179, 180,
181, 182, 183, 184, 185, 186,
187, 188, 189, 190, 191, 192,
193, 194, 195, 196, 197, 198,
199, 200, 201, 202, 203, 204,
205, 206, 207, 208, 209, 210,
211, 212, 213, 214, 215, 216,
217, 218, 219, 220, 221, 222,
223, 224, 225, 226, 227, 228,
229, 230, 231, 232, 233, 234,
235, 236, 237, 238, 239, 240,
241, 242, 243, 244, 245, 246,
247, 248, 249, 250, 251, 252,
253, 254, 255, 256, 257, 258,
259, 260, 261, 262, 263, 264,
265, 266, 267, 268, 269, 270,
271, 272, 273, 274, 275, 276,
277, 278, 279, 280, 281, 282,
283, 284, 285, 286, 287, 288,
289, 290, 291, 292, 293, 294,
295, 296, 297, 298, 299, 300,
301, 302, 303, 304, 305, 306,
307, 308, 309, 310, 311, 312,
313, 314, 315, 316, 317, 318,
319, 320, 321, 322, 323, 324,
325, 326, 327, 328, 329, 330,
331, 332, 333, 334, 335, 336,
337, 338, 339, 340, 341, 342,
343, 344, 345, 346, 347, 348,
349, 350, 351, 352, 353, 354,
355, 356, 357, 358, 359, 360,
361, 362, 363, 364, 365, 366,
367, 368, 369, 370, 371, 372,
373, 374, 375, 376, 377, 378,
379, 380, 381, 382, 383, 384,
385, 386, 387, 388, 389, 390,
391, 392, 393, 394, 395, 396,
397, 398, 399, 400, 401, 402,
403, 404, 405, 406, 407, 408,
409, 410, 411, 412, 413,
414, 415, 416, 417, 418,
419, 420, 421, 422, 423, 424,
425, 426, 427, 428, 429, 430,
431, 432, 433, 434, 435, 436,
437, 438, 439, 440, 441, 442,
443, 444, 445, 446, 447, 448,
449, 450, 451, 452, 453, 454,
455, 456, 457, 458, 459, 460,
461, 462, 463, 464, 465, 466,
467, 468, 469, 470, 471, 472,
473, 474, 475, 476, 477, 478,
479, 480, 481, 482, 483, 484,
485, 486, 487, 488, 489, 490,
491, 492, 493, 494, 495, 496,
497, 498, 499, 500, 501, 502,
503, 504, 505, 506, 507, 508,
509, 510, 511, 512, 513, 514,
515, 516, 517, 518, 519, 520,
521, 522, 523, 524, 525, 526,
527, 528, 529, 530, 531, 532,
533, 534, 535, 536, 537, 538,
539, 540, 541, 542, 543, 544,
545, 546, 547, 548, 549, 550,
551, 552, 553, 554, 555, 556,
557, 558, 559, 560, 561, 562,
563, 564, 565, 566, 567, 568,
569, 570, 571, 572, 573, 574,
575, 576, 577, 578, 579, 580,
581, 582, 583, 584, 585, 586,
587, 588, 589, 590, 591, 592,
593, 594, 595, 596, 597, 598,
599, 600, 601, 602, 603, 604,
605, 606, 607, 608, 609, 610,
611, 612, 613, 614, 615, 616,
617, 618, 619, 620, 621, 622,
623, 624, 625, 626, 627, 628,
629, 630, 631, 632, 633, 634,
635, 636, 637, 638, 639, 640,
641, 642, 643, 644, 645, 646,
647, 648, 649, 650, 651, 652,
653, 654, 655, 656, 657, 658,
659, 660, 661, 662, 663, 664,
665, 666, 667, 668, 669, 670,
671, 672, 673, 674, 675, 676,
677, 678, 679, 680, 681, 682,
683, 684, 685, 686, 687, 688,
689, 690, 691, 692, 693, 694,
695, 696, 697, 698, 699, 700,
701, 702, 703, 704, 705, 706,
707, 708, 709, 710, 711, 712,
713, 714, 715, 716, 717, 718,
719, 720, 721, 722, 723, 724,
725, 726, 727, 728, 729, 730,
731, 732, 733, 734, 735, 736,
737, 738, 739, 740, 741, 742,
743, 744, 745, 746, 747, 748,
749, 750, 751, 752, 753, 754,
755, 756, 757, 758, 759, 760,
761, 762, 763, 764, 765, 766,
767, 768, 769, 770, 771, 772,
773, 774, 775, 776, 777, 778,
779, 780, 781, 782, 783, 784,
785, 786, 787, 788, 789, 790,
791, 792, 793, 794, 795, 796,
797, 798, 799, 800, 801, 802,
803, 804, 805, 806, 807, 808,
809, 810, 811, 812, 813, 814,
815, 816, 817, 818, 819, 820,
821, 822, 823, 824, 825, 826,
827, 828, 829, 830, 831, 832,
833, 834, 835, 836, 837, 838,
839, 840, 841, 842, 843, 844,
845, 846, 847, 848, 849, 850,
851, 852, 853, 854, 855, 856,
857, 858, 859, 860, 861, 862,
863, 864, 865, 866, 867, 868,
869, 870, 871, 872, 873, 874,
875, 876, 877, 878, 879, 880,
881, 882, 883, 884, 885, 886,
887, 888, 889, 890, 891, 892,
893, 894, 895, 896, 897, 898,
899, 900, 901, 902, 903, 904,
905, 906, 907, 908, 909, 910,
911, 912, 913, 914, 915, 916,
917, 918, 919, 920, 921, 922,
923, 924, 925, 926, 927, 928,
929, 930, 931, 932, 933, 934,
935, 936, 937, 938, 939, 940,
941, 942, 943, 944, 945, 946,
947, 948, 949, 950, 951, 952,
953, 954, 955, 956, 957, 958,
959, 960, 961, 962, 963, 964,
965, 966, 967, 968, 969, 970,
971, 972, 973, 974, 975, 976,
977, 978, 979, 980, 981, 982,
983, 984, 985, 986, 987, 988,
989, 990, 991, 992, 993, 994,
995, 996, 997, 998, 999, 1000.

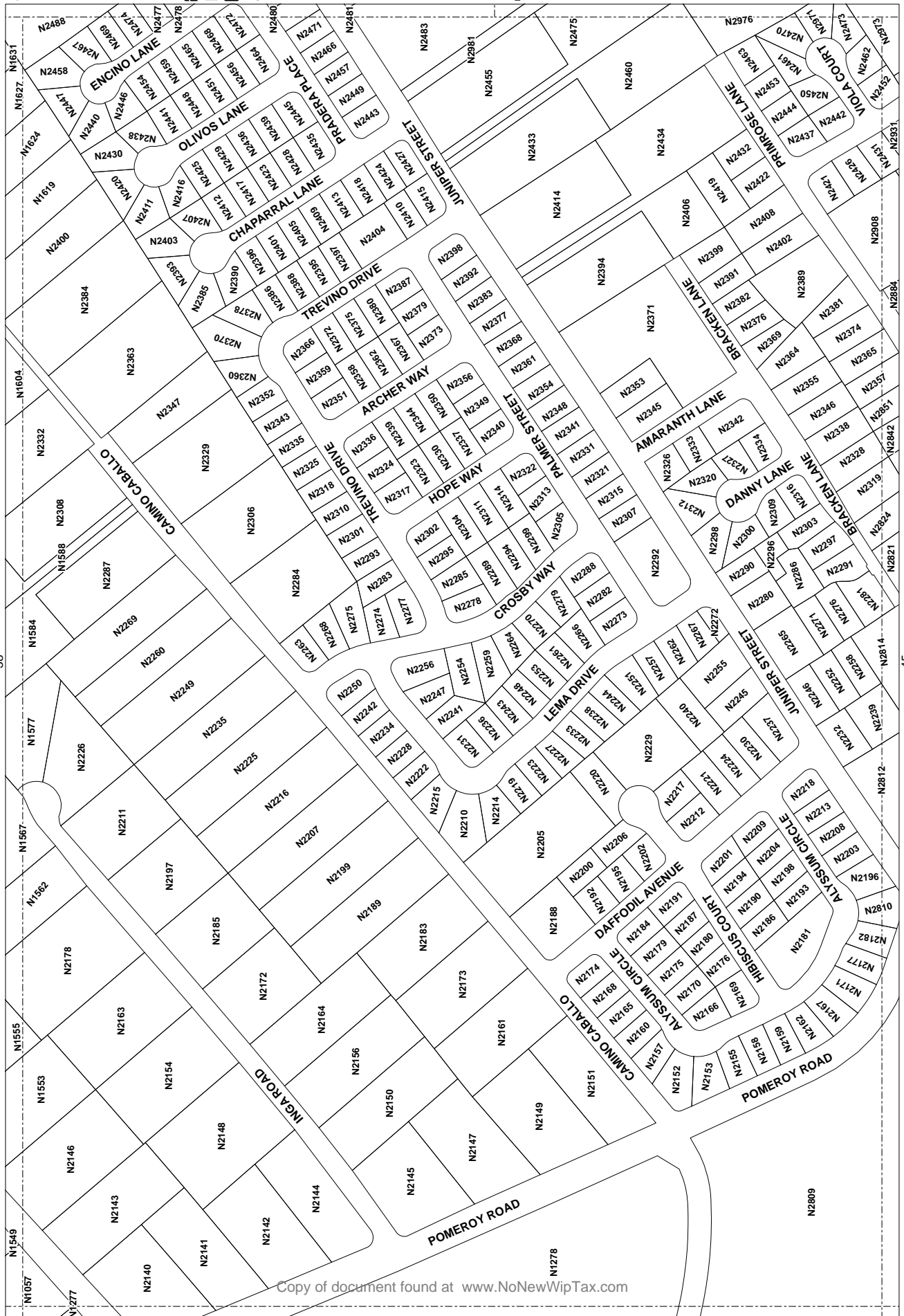

**ASSESSMENT
DIAGRAM**

NIPOMO MESA
SUPPLEMENTAL
ASSASSMENT DISTRICT
NO.1
NIPOMO COMMUNITY
SERVICES DISTRICT
STATE OF CALIFORNIA

- Legend**
- ASSM BOUNDARY
 - ASSESSOR PARCEL
 - DIAGRAM SHEET

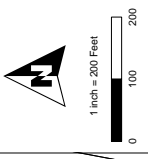

**SHEET:
43 OF 59**

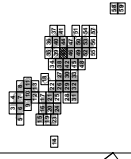

LOTS ON THIS SHEET ARE
BASED ON THE 1997
MAP COUNTY OF SAN LUIS
OBISPO, CA; BK 080 PGS:
072, 078, 079, 081, 082, 083,
084, 085, 086, 087, 088,
089, 090, 102, 103, 111, 121,
122, 123, 131, 132, 133, 134,
135, 136, 141, 142, 143, 144,
145, 146, 147, 148, 149, 150,
151, 152, 153, 154, 155, 156,
157, 158, 159, 160, 161, 162,
163, 164, 165, 166, 167, 168,
169, 170, 171, 172, 173, 174,
175, 176, 177, 178, 179, 180,
181, 182, 183, 184, 185, 186,
187, 188, 189, 190, 191, 192,
193, 194, 195, 196, 197, 198,
199, 200, 201, 202, 203, 204,
205, 206, 207, 208, 209, 210,
211, 212, 213, 214, 215, 216,
217, 218, 219, 220, 221, 222,
223, 224, 225, 226, 227, 228,
229, 230, 231, 232, 233, 234,
235, 236, 237, 238, 239, 240,
241, 242, 243, 244, 245, 246,
247, 248, 249, 250, 251, 252,
253, 254, 255, 256, 257, 258,
259, 260, 261, 262, 263, 264,
265, 266, 267, 268, 269, 270,
271, 272, 273, 274, 275, 276,
277, 278, 279, 280, 281, 282,
283, 284, 285, 286, 287, 288,
289, 290, 291, 292, 293, 294,
295, 296, 297, 298, 299, 300,
301, 302, 303, 304, 305, 306,
307, 308, 309, 310, 311, 312,
313, 314, 315, 316, 317, 318,
319, 320, 321, 322, 323, 324,
325, 326, 327, 328, 329, 330,
331, 332, 333, 334, 335, 336,
337, 338, 339, 340, 341, 342,
343, 344, 345, 346, 347, 348,
349, 350, 351, 352, 353, 354,
355, 356, 357, 358, 359, 360,
361, 362, 363, 364, 365, 366,
367, 368, 369, 370, 371, 372,
373, 374, 375, 376, 377, 378,
379, 380, 381, 382, 383, 384,
385, 386, 387, 388, 389, 390,
391, 392, 393, 394, 395, 396,
397, 398, 399, 400, 401, 402,
403, 404, 405, 406, 407, 408,
409, 410, 411, 412, 413,
414, 415, 416, 417, 418, 419,
420, 421, 422, 423, 424, 425,
426, 427, 428, 429, 430, 431,
432, 433, 434, 435, 436, 437,
438, 439, 440, 441, 442,
443, 444, 445, 446, 447, 448,
449, 450, 451, 452, 453, 454,
455, 456, 457, 458, 459, 460,
461, 462, 463, 464, 465, 466,
467, 468, 469, 470, 471, 472,
473, 474, 475, 476, 477, 478,
479, 480, 481, 482, 483, 484,
485, 486, 487, 488, 489, 490,
491, 492, 493, 494, 495, 496,
497, 498, 499, 500, 501, 502,
503, 504, 505, 506, 507, 508,
509, 510, 511, 512, 513, 514,
515, 516, 517, 518, 519, 520,
521, 522, 523, 524, 525, 526,
527, 528, 529, 530, 531, 532,
533, 534, 535, 536, 537, 538,
539, 540, 541, 542, 543, 544,
545, 546, 547, 548, 549, 550,
551, 552, 553, 554, 555, 556,
557, 558, 559, 560, 561, 562,
563, 564, 565, 566, 567, 568,
569, 570, 571, 572, 573, 574,
575, 576, 577, 578, 579, 580,
581, 582, 583, 584, 585, 586,
587, 588, 589, 590, 591, 592,
593, 594, 595, 596, 597, 598,
599, 600, 601, 602, 603, 604,
605, 606, 607, 608, 609, 610,
611, 612, 613, 614, 615, 616,
617, 618, 619, 620, 621, 622,
623, 624, 625, 626, 627, 628,
629, 630, 631, 632, 633, 634,
635, 636, 637, 638, 639, 640,
641, 642, 643, 644, 645, 646,
647, 648, 649, 650, 651, 652,
653, 654, 655, 656, 657, 658,
659, 660, 661, 662, 663, 664,
665, 666, 667, 668, 669, 670,
671, 672, 673, 674, 675, 676,
677, 678, 679, 680, 681, 682,
683, 684, 685, 686, 687, 688,
689, 690, 691, 692, 693, 694,
695, 696, 697, 698, 699, 700,
701, 702, 703, 704, 705, 706,
707, 708, 709, 710, 711, 712,
713, 714, 715, 716, 717, 718,
719, 720, 721, 722, 723, 724,
725, 726, 727, 728, 729, 730,
731, 732, 733, 734, 735, 736,
737, 738, 739, 740, 741, 742,
743, 744, 745, 746, 747, 748,
749, 750, 751, 752, 753, 754,
755, 756, 757, 758, 759, 760,
761, 762, 763, 764, 765, 766,
767, 768, 769, 770, 771, 772,
773, 774, 775, 776, 777, 778,
779, 780, 781, 782, 783, 784,
785, 786, 787, 788, 789, 790,
791, 792, 793, 794, 795, 796,
797, 798, 799, 800, 801, 802,
803, 804, 805, 806, 807, 808,
809, 810, 811, 812, 813, 814,
815, 816, 817, 818, 819, 820,
821, 822, 823, 824, 825, 826,
827, 828, 829, 830, 831, 832,
833, 834, 835, 836, 837, 838,
839, 840, 841, 842, 843, 844,
845, 846, 847, 848, 849, 850,
851, 852, 853, 854, 855, 856,
857, 858, 859, 860, 861, 862,
863, 864, 865, 866, 867, 868,
869, 870, 871, 872, 873, 874,
875, 876, 877, 878, 879, 880,
881, 882, 883, 884, 885, 886,
887, 888, 889, 890, 891, 892,
893, 894, 895, 896, 897, 898,
899, 900, 901, 902, 903, 904,
905, 906, 907, 908, 909, 910,
911, 912, 913, 914, 915, 916,
917, 918, 919, 920, 921, 922,
923, 924, 925, 926, 927, 928,
929, 930, 931, 932, 933, 934,
935, 936, 937, 938, 939, 940,
941, 942, 943, 944, 945, 946,
947, 948, 949, 950, 951, 952,
953, 954, 955, 956, 957, 958,
959, 960, 961, 962, 963, 964,
965, 966, 967, 968, 969, 970,
971, 972, 973, 974, 975, 976,
977, 978, 979, 980, 981, 982,
983, 984, 985, 986, 987, 988,
989, 990, 991, 992, 993, 994,
995, 996, 997, 998, 999, 1000

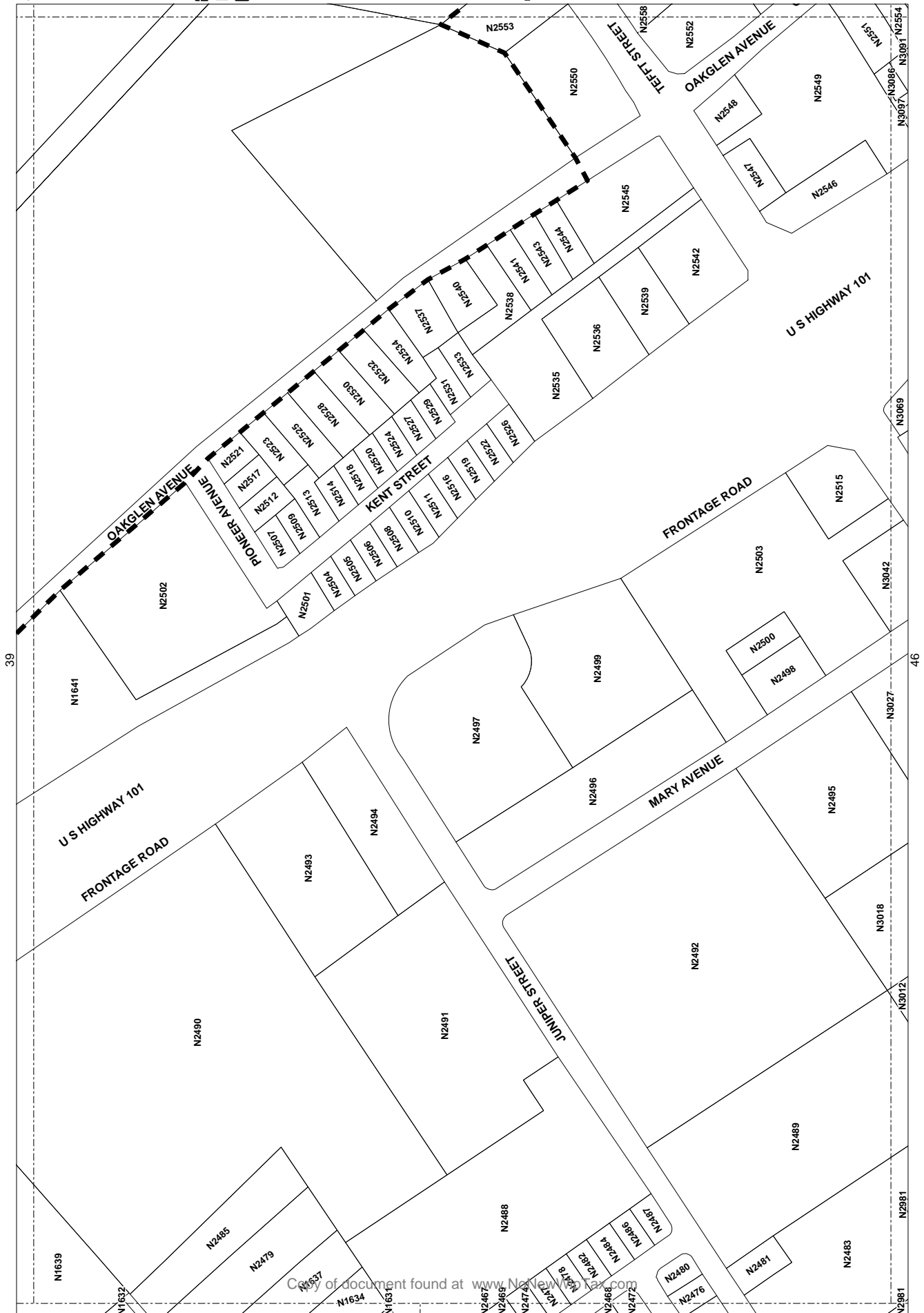





**ASSESSMENT
DIAGRAM**

NIPOMO MESA
SUPPLEMENTAL
ASSESSMENT DISTRICT
NO. 1

NIPOMO COMMUNITY
SERVICES DISTRICT
STATE OF CALIFORNIA

Legend

-  ASSM BOUNDARY
-  ASSESSOR PARCEL
-  DIAGRAM SHEET



1 inch = 200 Feet

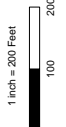

**SHEET:
44 OF 59**



LOTS ON THIS SHEET ARE
IDENTIFIED BY PARCEL
MAP COUNTY OF SAN LUIS
OBISPO, CA; BK 080 PGS:
072, 078, 079, 081, 082, 083,
084, 085, 086, 087, 088, 089,
095, 101, 102, 103, 111, 121,
122, 123, 131, 132, 133, 134,
135, 146, 147, 148, 149, 150,
151, 152, 153, 154, 155, 156,
157, 158, 159, 160, 161, 162,
163, 164, 165, 166, 167, 168,
169, 170, 171, 172, 173, 174,
175, 176, 177, 178, 179, 180,
181, 182, 183, 184, 185, 186,
187, 188, 189, 190, 191, 192,
193, 194, 195, 196, 197, 198,
199, 200, 201, 202, 203, 204,
205, 206, 207, 208, 209, 210,
211, 212, 213, 214, 215, 216,
217, 218, 219, 220, 221, 222,
223, 224, 225, 226, 227, 228,
229, 230, 231, 232, 233, 234,
235, 236, 237, 238, 239, 240,
241, 242, 243, 244, 245, 246,
247, 248, 249, 250, 251, 252,
253, 254, 255, 256, 257, 258,
259, 260, 261, 262, 263, 264,
265, 266, 267, 268, 269, 270,
271, 272, 273, 274, 275, 276,
277, 278, 279, 280, 281, 282,
283, 284, 285, 286, 287, 288,
289, 290, 291, 292, 293, 294,
295, 296, 297, 298, 299, 300,
301, 302, 303, 304, 305, 306,
307, 308, 309, 310, 311, 312,
313, 314, 315, 316, 317, 318,
319, 320, 321, 322, 323, 324,
325, 326, 327, 328, 329, 330,
331, 332, 333, 334, 335, 336,
337, 338, 339, 340, 341, 342,
343, 344, 345, 346, 347, 348,
349, 350, 351, 352, 353, 354,
355, 356, 357, 358, 359, 360,
361, 362, 363, 364, 365, 366,
367, 368, 369, 370, 371, 372,
373, 374, 375, 376, 377, 378,
379, 380, 381, 382, 383, 384,
385, 386, 387, 388, 389, 390,
391, 392, 393, 394, 395, 396,
397, 398, 399, 400, 401, 402,
403, 404, 405, 406, 407, 408,
409, 410, 411, 412, 413,
414, 415, 416, 417, 418, 419,
420, 421, 422, 423, 424, 425,
426, 427, 428, 429, 430, 431,
432, 433, 434, 435, 436, 437,
438, 439, 440, 441, 442,
443, 444, 445, 446,
447, 448, 449, 450, 451, 452,
453, 454, 455, 456, 457, 458,
459, 460, 461, 462, 463, 464,
465, 466, 467, 468, 469, 470,
471, 472, 473, 474, 475, 476,
477, 478, 479, 480, 481, 482,
483, 484, 485, 486, 487, 488,
489, 490, 491, 492, 493, 494,
495, 496, 497, 498, 499, 500,
501, 502, 503, 504, 505, 506,
507, 508, 509, 510, 511, 512,
513, 514, 515, 516, 517, 518,
519, 520, 521, 522, 523, 524,
525, 526, 527, 528, 529, 530,
531, 532, 533, 534, 535, 536,
537, 538, 539, 540, 541, 542,
543, 544, 545, 546, 547, 548,
549, 550, 551, 552, 553, 554,
555, 556, 557, 558, 559, 560,
561, 562, 563, 564, 565, 566,
567, 568, 569, 570, 571, 572,
573, 574, 575, 576, 577.



**ASSESSMENT
DIAGRAM**

NIPOMO MESA
SUPPLEMENTAL
ASSESSMENT DISTRICT
NO. 1
NIPOMO COMMUNITY
SERVICES DISTRICT
STATE OF CALIFORNIA

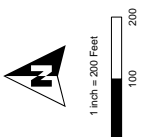
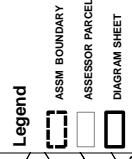

**SHEET:
46 OF 59**





LOTS ON THIS SHEET ARE
EXCEPTED FROM THE
MAP COUNTY OF SAN LUIS
OBISPO, CA; BK 080 PGS:
072, 078, 079, 081, 082, 083,
084, 085, 086, 087, 088,
089, 090, 102, 103, 111, 121,
122, 123, 131, 132, 133, 134,
135, 144, 145, 146, 147, 148,
149, 150, 151, 152, 153,
154, 155, 156, 157, 158,
159, 160, 161, 162, 163, 164,
165, 166, 167, 168, 169, 170,
171, 172, 173, 174, 175, 176,
177, 178, 179, 180, 181, 182,
183, 184, 185, 186, 187, 188,
189, 190, 191, 192, 193, 194,
195, 196, 197, 198, 199, 200,
201, 202, 203, 204, 205, 206,
207, 208, 209, 210, 211, 212,
213, 214, 215, 216, 217, 218,
219, 220, 221, 222, 223, 224,
225, 226, 227, 228, 229, 230,
231, 232, 233, 234, 235, 236,
237, 238, 239, 240, 241, 242,
243, 244, 245, 246, 247,
248, 249, 250, 251, 252, 253,
254, 255, 256, 257, 258,
259, 260, 261, 262, 263, 264,
265, 266, 267, 268, 269, 270,
271, 272, 273, 274, 275, 276,
277, 278, 279, 280, 281, 282,
283, 284, 285, 286, 287, 288,
289, 290, 291, 292, 293, 294,
295, 296, 297, 298, 299, 300,
301, 302, 303, 304, 305, 306,
307, 308, 309, 310, 311, 312,
313, 314, 315, 316, 317, 318,
319, 320, 321, 322, 323, 324,
325, 326, 327, 328, 329, 330,
331, 332, 333, 334, 335, 336,
337, 338, 339, 340, 341, 342,
343, 344, 345, 346, 347, 348,
349, 350, 351, 352, 353, 354,
355, 356, 357, 358, 359, 360,
361, 362, 363, 364, 365, 366,
367, 368, 369, 370, 371, 372,
373, 374, 375, 376, 377, 378,
379, 380, 381, 382, 383, 384,
385, 386, 387, 388, 389, 390,
391, 392, 393, 394, 395, 396,
397, 398, 399, 400, 401, 402,
403, 404, 405, 406, 407, 408,
409, 410, 411, 412, 413, 414,
415, 416, 417, 418, 419, 420,
421, 422, 423, 424, 425, 426,
427, 428, 429, 430, 431, 432,
433, 434, 435, 436, 437, 438,
439, 440, 441, 442, 443,
444, 445, 446, 447, 448,
449, 450, 451, 452, 453, 454,
455, 456, 457, 458, 459, 460,
461, 462, 463, 464, 465, 466,
467, 468, 469, 470, 471, 472,
473, 474, 475, 476, 477, 478,
479, 480, 481, 482, 483, 484,
485, 486, 487, 488, 489, 490,
491, 492, 493, 494, 495, 496,
497, 498, 499, 500, 501, 502,
503, 504, 505, 506, 507, 508,
509, 510, 511, 512, 513, 514,
515, 516, 517, 518, 519, 520,
521, 522, 523, 524, 525, 526,
527, 528, 529, 530, 531, 532,
533, 534, 535, 536, 537, 538,
539, 540, 541, 542, 543, 544,
545, 546, 547, 548, 549, 550,
551, 552, 553, 554, 555, 556,
557, 558, 559, 560, 561, 562,
563, 564, 565, 566, 567, 568,
569, 570, 571, 572, 573, 574,
575, 576, 577, 578, 579, 580,
581, 582, 583, 584, 585, 586,
587, 588, 589, 590, 591, 592,
593, 594, 595, 596, 597, 598,
599, 600, 601, 602, 603, 604,
605, 606, 607, 608, 609, 610,
611, 612, 613, 614, 615, 616,
617, 618, 619, 620, 621, 622,
623, 624, 625, 626, 627, 628,
629, 630, 631, 632, 633, 634,
635, 636, 637, 638, 639, 640,
641, 642, 643, 644, 645, 646,
647, 648, 649, 650, 651, 652,
653, 654, 655, 656, 657, 658,
659, 660, 661, 662, 663, 664,
665, 666, 667, 668, 669, 670,
671, 672, 673, 674, 675, 676,
677, 678, 679, 680, 681, 682,
683, 684, 685, 686, 687, 688,
689, 690, 691, 692, 693, 694,
695, 696, 697, 698, 699, 700,
701, 702, 703, 704, 705, 706,
707, 708, 709, 710, 711, 712,
713, 714, 715, 716, 717, 718,
719, 720, 721, 722, 723, 724,
725, 726, 727, 728, 729, 730,
731, 732, 733, 734, 735, 736,
737, 738, 739, 740, 741, 742,
743, 744, 745, 746, 747, 748,
749, 750, 751, 752, 753, 754,
755, 756, 757, 758, 759, 760,
761, 762, 763, 764, 765, 766,
767, 768, 769, 770, 771, 772,
773, 774, 775, 776, 777, 778,
779, 780, 781, 782, 783, 784,
785, 786, 787, 788, 789, 790,
791, 792, 793, 794, 795, 796,
797, 798, 799, 800, 801, 802,
803, 804, 805, 806, 807, 808,
809, 810, 811, 812, 813, 814,
815, 816, 817, 818, 819, 820,
821, 822, 823, 824, 825, 826,
827, 828, 829, 830, 831, 832,
833, 834, 835, 836, 837, 838,
839, 840, 841, 842, 843, 844,
845, 846, 847, 848, 849, 850,
851, 852, 853, 854, 855, 856,
857, 858, 859, 860, 861, 862,
863, 864, 865, 866, 867, 868,
869, 870, 871, 872, 873, 874,
875, 876, 877, 878, 879, 880,
881, 882, 883, 884, 885, 886,
887, 888, 889, 890, 891, 892,
893, 894, 895, 896, 897, 898,
899, 900, 901, 902, 903, 904,
905, 906, 907, 908, 909, 910,
911, 912, 913, 914, 915, 916,
917, 918, 919, 920, 921, 922,
923, 924, 925, 926, 927, 928,
929, 930, 931, 932, 933, 934,
935, 936, 937, 938, 939, 940,
941, 942, 943, 944, 945, 946,
947, 948, 949, 950, 951, 952,
953, 954, 955, 956, 957, 958,
959, 960, 961, 962, 963, 964,
965, 966, 967, 968, 969, 970,
971, 972, 973, 974, 975, 976,
977, 978, 979, 980, 981, 982,
983, 984, 985, 986, 987, 988,
989, 990, 991, 992, 993, 994,
995, 996, 997, 998, 999, 1000



**ASSESSMENT
DIAGRAM**

NIPOMO MESA
SUPPLEMENTAL
ASSASSMENT DISTRICT
NO.1
NIPOMO COMMUNITY
SERVICES DISTRICT
STATE OF CALIFORNIA

- Legend**
-  ASSESSMENT BOUNDARY
 -  ASSESSOR PARCEL
 -  DIAGRAM SHEET

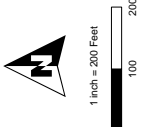

**SHEET:
48 OF 59**



LOTS ON THIS SHEET ARE
NOT TO BE USED FOR
MAP COUNTY OF SAN LUIS
OBISPO, CA; BK 080 PGS:
072, 078, 079, 081, 082, 083,
084, 085, 086, 087, 088, 089,
090, 091, 092, 093, 094, 095,
096, 097, 098, 099, 100, 101,
102, 103, 104, 105, 106, 107,
108, 109, 110, 111, 112, 113,
114, 115, 116, 117, 118, 119,
120, 121, 122, 123, 124, 125,
126, 127, 128, 129, 130, 131,
132, 133, 134, 135, 136, 137,
138, 139, 140, 141, 142, 143,
144, 145, 146, 147, 148, 149,
150, 151, 152, 153, 154, 155,
156, 157, 158, 159, 160, 161,
162, 163, 164, 165, 166, 167,
168, 169, 170, 171, 172, 173,
174, 175, 176, 177, 178, 179,
180, 181, 182, 183, 184, 185,
186, 187, 188, 189, 190, 191,
192, 193, 194, 195, 196, 197,
198, 199, 200, 201, 202, 203,
204, 205, 206, 207, 208, 209,
210, 211, 212, 213, 214, 215,
216, 217, 218, 219, 220, 221,
222, 223, 224, 225, 226, 227,
228, 229, 230, 231, 232, 233,
234, 235, 236, 237, 238, 239,
240, 241, 242, 243, 244, 245,
246, 247, 248, 249, 250, 251,
252, 253, 254, 255, 256, 257,
258, 259, 260, 261, 262, 263,
264, 265, 266, 267, 268, 269,
270, 271, 272, 273, 274, 275,
276, 277, 278, 279, 280, 281,
282, 283, 284, 285, 286, 287,
288, 289, 290, 291, 292, 293,
294, 295, 296, 297, 298, 299,
300, 301, 302, 303, 304, 305,
306, 307, 308, 309, 310, 311,
312, 313, 314, 315, 316, 317,
318, 319, 320, 321, 322, 323,
324, 325, 326, 327, 328, 329,
330, 331, 332, 333, 334, 335,
336, 337, 338, 339, 340, 341,
342, 343, 344, 345, 346, 347,
348, 349, 350, 351, 352, 353,
354, 355, 356, 357, 358, 359,
360, 361, 362, 363, 364, 365,
366, 367, 368, 369, 370, 371,
372, 373, 374, 375, 376, 377,
378, 379, 380, 381, 382, 383,
384, 385, 386, 387, 388, 389,
390, 391, 392, 393, 394, 395,
396, 397, 398, 399, 400, 401,
402, 403, 404, 405, 406, 407,
408, 409, 410, 411, 412, 413,
414, 415, 416, 417, 418, 419,
420, 421, 422, 423, 424, 425,
426, 427, 428, 429, 430, 431,
432, 433, 434, 435, 436, 437,
438, 439, 440, 441, 442, 443,
444, 445, 446, 447, 448, 449,
450, 451, 452, 453, 454, 455,
456, 457, 458, 459, 460, 461,
462, 463, 464, 465, 466, 467,
468, 469, 470, 471, 472, 473,
474, 475, 476, 477, 478, 479,
480, 481, 482, 483, 484, 485,
486, 487, 488, 489, 490, 491,
492, 493, 494, 495, 496, 497,
498, 499, 500, 501, 502, 503,
504, 505, 506, 507, 508, 509,
510, 511, 512, 513, 514, 515,
516, 517, 518, 519, 520, 521,
522, 523, 524, 525, 526, 527,
528, 529, 530, 531, 532, 533,
534, 535, 536, 537, 538, 539,
540, 541, 542, 543, 544, 545,
546, 547, 548, 549, 550, 551,
552, 553, 554, 555, 556, 557,
558, 559, 560, 561, 562, 563,
564, 565, 566, 567, 568, 569,
570, 571, 572, 573, 574, 575, 576,
577, 578, 579, 580, 581, 582,
583, 584, 585, 586, 587, 588,
589, 590, 591, 592, 593, 594,
595, 596, 597, 598, 599, 600.



**ASSESSMENT
DIAGRAM**

NIPOMO MESA
SUPPLEMENTAL
ASSESSMENT DISTRICT
NO. 1
NIPOMO COMMUNITY
SERVICES DISTRICT
STATE OF CALIFORNIA

Legend

- ASSM BOUNDARY
- ASSESSOR PARCEL
- DIAGRAM SHEET

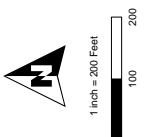

**SHEET:
49 OF 59**

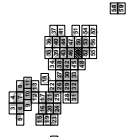

LOTS ON THIS SHEET ARE
NOT TO BE USED FOR
MAP COUNTY OF SAN LUIS
OBISPO, CA; BK 080 PGS:
072, 078, 079, 081, 082, 083,
084, 085, 086, 087, 088, 089,
090, 091, 092, 093, 094,
095, 096, 097, 098, 099, 100,
101, 102, 103, 104, 105,
106, 107, 108, 109, 110, 111,
112, 113, 114, 115, 116, 117,
118, 119, 120, 121, 122, 123,
124, 125, 126, 127, 128, 129,
130, 131, 132, 133, 134, 135,
136, 137, 138, 139, 140, 141,
142, 143, 144, 145, 146, 147,
148, 149, 150, 151, 152, 153,
154, 155, 156, 157, 158, 159,
160, 161, 162, 163, 164, 165,
166, 167, 168, 169, 170, 171,
172, 173, 174, 175, 176, 177,
178, 179, 180, 181, 182, 183,
184, 185, 186, 187, 188, 189,
190, 191, 192, 193, 194, 195,
196, 197, 198, 199, 200, 201,
202, 203, 204, 205, 206, 207,
208, 209, 210, 211, 212, 213,
214, 215, 216, 217, 218, 219,
220, 221, 222, 223, 224, 225,
226, 227, 228, 229, 230, 231,
232, 233, 234, 235, 236, 237,
238, 239, 240, 241, 242, 243,
244, 245, 246, 247, 248, 249,
250, 251, 252, 253, 254, 255,
256, 257, 258, 259, 260, 261,
262, 263, 264, 265, 266, 267,
268, 269, 270, 271, 272, 273,
274, 275, 276, 277, 278, 279,
280, 281, 282, 283, 284, 285,
286, 287, 288, 289, 290, 291,
292, 293, 294, 295, 296, 297,
298, 299, 300, 301, 302, 303,
304, 305, 306, 307, 308, 309,
310, 311, 312, 313, 314, 315,
316, 317, 318, 319, 320, 321,
322, 323, 324, 325, 326, 327,
328, 329, 330, 331, 332, 333,
334, 335, 336, 337, 338, 339,
340, 341, 342, 343, 344, 345,
346, 347, 348, 349, 350, 351,
352, 353, 354, 355, 356, 357,
358, 359, 360, 361, 362, 363,
364, 365, 366, 367, 368, 369,
370, 371, 372, 373, 374, 375,
376, 377, 378, 379, 380, 381,
382, 383, 384, 385, 386, 387,
388, 389, 390, 391, 392, 393,
394, 395, 396, 397, 398, 399,
400, 401, 402, 403, 404, 405,
406, 407, 408, 409, 410, 411,
412, 413, 414, 415, 416, 417,
418, 419, 420, 421, 422, 423,
424, 425, 426, 427, 428, 429,
430, 431, 432, 433, 434, 435,
436, 437, 438, 439, 440, 441,
442, 443, 444, 445, 446, 447,
448, 449, 450, 451, 452, 453,
454, 455, 456, 457, 458, 459,
460, 461, 462, 463, 464, 465,
466, 467, 468, 469, 470, 471,
472, 473, 474, 475, 476, 477,
478, 479, 480, 481, 482, 483,
484, 485, 486, 487, 488, 489,
490, 491, 492, 493, 494, 495,
496, 497, 498, 499, 500, 501,
502, 503, 504, 505, 506, 507,
508, 509, 510, 511, 512, 513,
514, 515, 516, 517, 518, 519,
520, 521, 522, 523, 524, 525,
526, 527, 528, 529, 530, 531,
532, 533, 534, 535, 536, 537,
538, 539, 540, 541, 542, 543,
544, 545, 546, 547, 548, 549,
550, 551, 552, 553, 554, 555, 556,
557, 558, 559, 560, 561, 562,
563, 564, 565, 566, 567, 568,
569, 570, 571, 572, 573, 574, 575,
576, 577, 578, 579, 580, 581,
582, 583, 584, 585, 586, 587,
588, 589, 590, 591, 592, 593,
594, 595, 596, 597, 598, 599,
600, 601, 602, 603, 604, 605,
606, 607, 608, 609, 610, 611,
612, 613, 614, 615, 616, 617,
618, 619, 620, 621, 622, 623,
624, 625, 626, 627, 628, 629,
630, 631, 632, 633, 634, 635,
636, 637, 638, 639, 640, 641,
642, 643, 644, 645, 646, 647,
648, 649, 650, 651, 652, 653,
654, 655, 656, 657, 658, 659,
660, 661, 662, 663, 664, 665,
666, 667, 668, 669, 670, 671,
672, 673, 674, 675, 676, 677,
678, 679, 680, 681, 682, 683,
684, 685, 686, 687, 688, 689,
690, 691, 692, 693, 694, 695,
696, 697, 698, 699, 700, 701,
702, 703, 704, 705, 706, 707,
708, 709, 710, 711, 712, 713,
714, 715, 716, 717, 718, 719,
720, 721, 722, 723, 724, 725,
726, 727, 728, 729, 730, 731,
732, 733, 734, 735, 736, 737,
738, 739, 740, 741, 742, 743,
744, 745, 746, 747, 748, 749,
750, 751, 752, 753, 754, 755,
756, 757, 758, 759, 760, 761,
762, 763, 764, 765, 766, 767,
768, 769, 770, 771, 772, 773,
774, 775, 776, 777, 778, 779,
780, 781, 782, 783, 784, 785,
786, 787, 788, 789, 790, 791,
792, 793, 794, 795, 796, 797,
798, 799, 800, 801, 802, 803,
804, 805, 806, 807, 808, 809,
810, 811, 812, 813, 814, 815,
816, 817, 818, 819, 820, 821,
822, 823, 824, 825, 826, 827,
828, 829, 830, 831, 832, 833,
834, 835, 836, 837, 838, 839,
840, 841, 842, 843, 844, 845,
846, 847, 848, 849, 850, 851,
852, 853, 854, 855, 856, 857,
858, 859, 860, 861, 862, 863,
864, 865, 866, 867, 868, 869,
870, 871, 872, 873, 874, 875,
876, 877, 878, 879, 880, 881,
882, 883, 884, 885, 886, 887,
888, 889, 890, 891, 892, 893,
894, 895, 896, 897, 898, 899,
900, 901, 902, 903, 904, 905,
906, 907, 908, 909, 910, 911,
912, 913, 914, 915, 916, 917,
918, 919, 920, 921, 922, 923,
924, 925, 926, 927, 928, 929,
930, 931, 932, 933, 934, 935,
936, 937, 938, 939, 940, 941,
942, 943, 944, 945, 946, 947,
948, 949, 950, 951, 952, 953,
954, 955, 956, 957, 958, 959,
960, 961, 962, 963, 964, 965,
966, 967, 968, 969, 970, 971,
972, 973, 974, 975, 976, 977,
978, 979, 980, 981, 982, 983,
984, 985, 986, 987, 988, 989,
990, 991, 992, 993, 994, 995,
996, 997, 998, 999, 1000





**ASSESSMENT
DIAGRAM**

NIPOMO MESA
SUPPLEMENTAL
SERVICES DISTRICT
ASSESSMENT DISTRICT
NO.1

NIPOMO COMMUNITY
SERVICES DISTRICT
STATE OF CALIFORNIA

Legend

-  ASSESSOR PARCEL
-  ASSESSOR PARCEL
-  ASSESSOR PARCEL

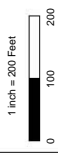

**SHEET:
51 OF 59**



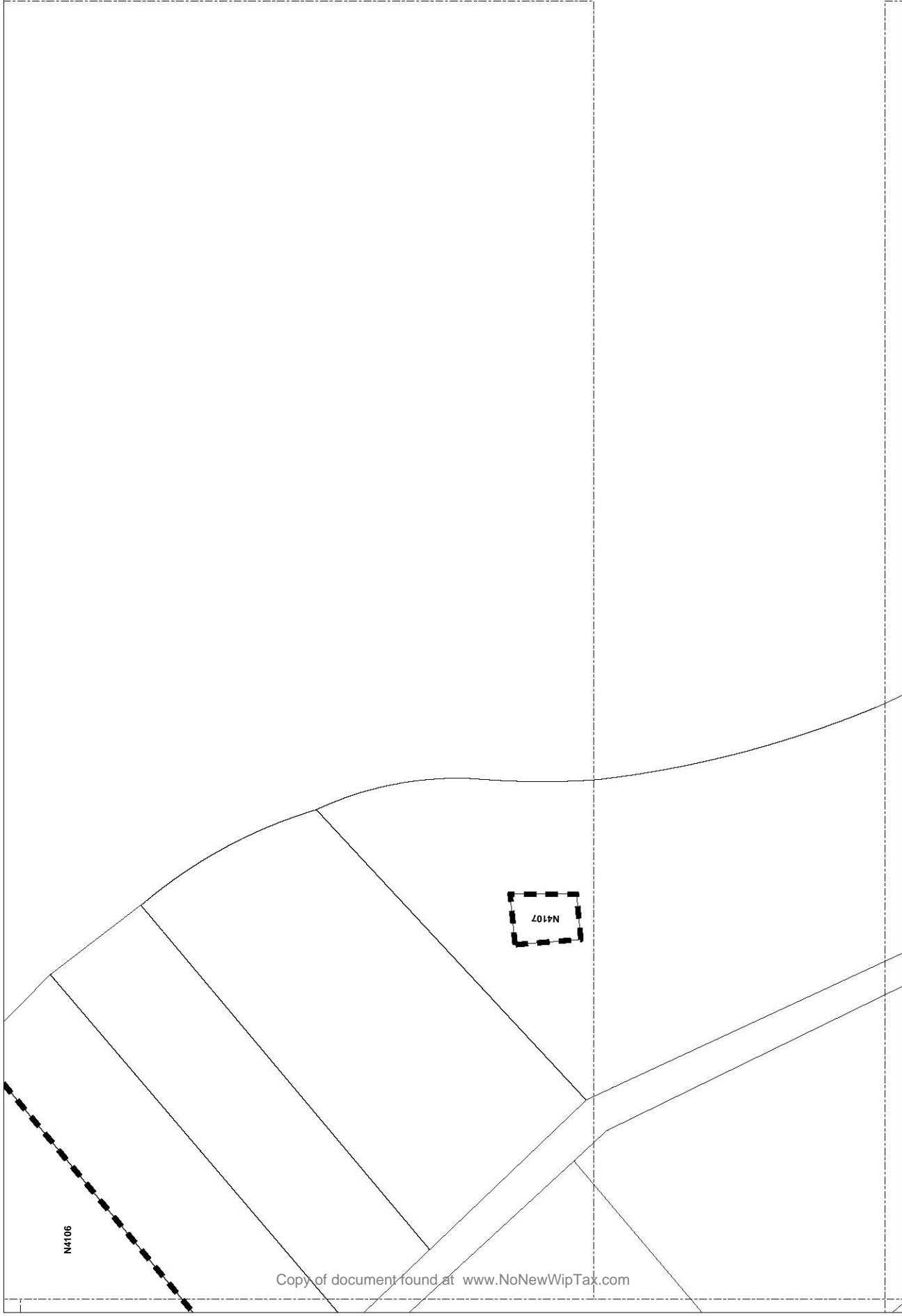

LOTS ON THIS SHEET ARE
MAP COUNTY OF SAN LUIS
OBISPO, CA; BK 080 PGS:
072, 078, 079, 081, 082, 083,
084, 085, 086, 087, 088, 089,
095, 101, 102, 103, 111, 121,
122, 123, 131, 132, 133, 134,
135, 146, 147, 148, 149, 150,
151, 152, 153, 154, 155,
156, 157, 158, 159, 160, 161,
162, 163, 164, 165, 166, 167,
168, 169, 170, 171, 172, 173,
174, 175, 176, 177, 178, 179,
180, 181, 182, 183, 184, 185,
186, 187, 188, 189, 190, 191,
192, 193, 194, 195, 196, 197,
198, 199, 200, 201, 202, 203,
204, 205, 206, 207, 208, 209,
210, 211, 212, 213, 214, 215,
216, 217, 218, 219, 220, 221,
222, 223, 243, 244, 246, 247,
248, 249, 250, 251, 252, 253,
254, 255, 256, 257, 258, 259,
260, 261, 262, 263, 264, 265,
266, 267, 268, 269, 270, 271,
272, 273, 274, 275, 276, 277,
278, 279, 280, 281, 282, 283,
284, 285, 286, 287, 288, 289,
290, 291, 292, 293, 294, 295,
296, 297, 298, 299, 300, 301,
302, 303, 304, 305, 306, 307,
308, 309, 310, 311, 312, 313,
314, 315, 316, 317, 318, 319,
320, 321, 322, 323, 324, 325,
326, 327, 328, 329, 330, 331,
332, 333, 334, 335, 336, 337,
338, 339, 340, 341, 342, 343,
344, 345, 346, 347, 348, 349,
350, 351, 352, 353, 354, 355,
356, 357, 358, 359, 360, 361,
362, 363, 364, 365, 366, 367,
368, 369, 370, 371, 372, 373,
374, 375, 376, 381, 382, 410, 411,
412, 413, 414, 415, 416, 417,
418, 419, 420, 421, 422, 423,
424, 425, 426, 427, 428, 429,
430, 431, 440, 441, 442,
443, 444, 445, 446,
BK 092 PGS: 081, 082, 083,
084, 085, 086, 087, 088, 089,
090, 091, 092, 093, 094, 095,
141, 142, 143, 144, 145, 146,
147, 148, 149, 150, 152, 153,
154, 155, 156, 157, 158, 159,
281, 282, 283, 284, 285, 286,
287, 288, 289, 291, 302,
303, 304, 311, 321, 331, 341,
351, 361, 371, 381, 391, 401,
385, 462, 463, 510, 512, 513,
531, 532, 533, 534, 551, 570,
571, 572, 573, 574, 575, 576,
577.



**ASSESSMENT
DIAGRAM**

NIPOMO MESA
SUPPLEMENTAL
ASSESSMENT DISTRICT
NO. 1
NIPOMO COMMUNITY
SERVICES DISTRICT
STATE OF CALIFORNIA

Legend

-  ASSESSMENT BOUNDARY
-  ASSESSOR PARCEL
-  DIAGRAM SHEET



1 inch = 200 Feet

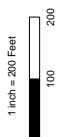

**SHEET:
52 OF 59**

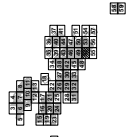



LOTS ON THIS SHEET ARE
NOT TO BE USED FOR
MAP COUNTY OF SAN LUIS
OBISPO, CA; BK 080 PGS:
072, 078, 079, 081, 082, 083,
084, 085, 086, 087, 088, 089,
090, 101, 102, 103, 111, 121,
122, 123, 131, 132, 133, 134,
135, 141, 142, 143, 144, 145,
151, 152, 161, 162, 163, 164,
171, 172, 181, 182, 183, 184,
191, 192, 201, 202, 203, 204,
211, 212, 221, 222, 223, 224,
231, 232, 241, 242, 243, 244,
251, 252, 261, 262, 263, 264,
271, 272, 281, 282, 283, 284,
291, 292, 301, 302, 303, 304,
311, 312, 321, 322, 323, 324,
331, 332, 341, 342, 343, 344,
351, 352, 353, 354, 355, 356,
361, 362, 363, 364, 365, 366,
371, 372, 373, 374, 375, 376,
381, 382, 383, 384, 385, 386,
391, 392, 393, 394, 395, 396,
397, 398, 399, 400, 401, 402,
403, 404, 405, 406, 407, 408,
409, 410, 411, 412, 413,
414, 415, 416, 417, 418,
419, 420, 421, 422, 423, 424,
425, 426, 427, 428, 429, 430,
431, 432, 433, 434, 435, 436,
437, 438, 439, 440, 441, 442,
443, 444, 445, 446, 447,
448, 449, 450, 451, 452, 453,
454, 455, 456, 457, 458, 459,
460, 461, 462, 463, 464, 465,
466, 467, 468, 469, 470, 471,
472, 473, 474, 475, 476, 477,
478, 479, 480, 481, 482, 483,
484, 485, 486, 487, 488, 489,
490, 491, 492, 493, 494, 495,
496, 497, 498, 499, 500, 501,
502, 503, 504, 505, 506, 507,
508, 509, 510, 511, 512, 513,
514, 515, 516, 517, 518, 519,
520, 521, 522, 523, 524, 525,
526, 527, 528, 529, 530, 531,
532, 533, 534, 535, 536, 537,
538, 539, 540, 541, 542, 543,
544, 545, 546, 547, 548, 549,
550, 551, 552, 553, 554, 555, 556,
557, 558, 559, 560, 561, 562,
563, 564, 565, 566, 567, 568,
569, 570, 571, 572, 573, 574,
575, 576, 577, 578, 579, 580,
581, 582, 583, 584, 585, 586,
587, 588, 589, 590, 591, 592,
593, 594, 595, 596, 597, 598,
599, 600, 601, 602, 603, 604,
605, 606, 607, 608, 609, 610,
611, 612, 613, 614, 615, 616,
617, 618, 619, 620, 621, 622,
623, 624, 625, 626, 627, 628,
629, 630, 631, 632, 633, 634,
635, 636, 637, 638, 639, 640,
641, 642, 643, 644, 645, 646,
647, 648, 649, 650, 651, 652,
653, 654, 655, 656, 657, 658,
659, 660, 661, 662, 663, 664,
665, 666, 667, 668, 669, 670,
671, 672, 673, 674, 675, 676,
677, 678, 679, 680, 681, 682,
683, 684, 685, 686, 687, 688,
689, 690, 691, 692, 693, 694,
695, 696, 697, 698, 699, 700,
701, 702, 703, 704, 705, 706,
707, 708, 709, 710, 711, 712,
713, 714, 715, 716, 717, 718,
719, 720, 721, 722, 723, 724,
725, 726, 727, 728, 729, 730,
731, 732, 733, 734, 735, 736,
737, 738, 739, 740, 741, 742,
743, 744, 745, 746, 747, 748,
749, 750, 751, 752, 753, 754,
755, 756, 757, 758, 759, 760,
761, 762, 763, 764, 765, 766,
767, 768, 769, 770, 771, 772,
773, 774, 775, 776, 777, 778,
779, 780, 781, 782, 783, 784,
785, 786, 787, 788, 789, 790,
791, 792, 793, 794, 795, 796,
797, 798, 799, 800, 801, 802,
803, 804, 805, 806, 807, 808,
809, 810, 811, 812, 813, 814,
815, 816, 817, 818, 819, 820,
821, 822, 823, 824, 825, 826,
827, 828, 829, 830, 831, 832,
833, 834, 835, 836, 837, 838,
839, 840, 841, 842, 843, 844,
845, 846, 847, 848, 849, 850,
851, 852, 853, 854, 855, 856,
857, 858, 859, 860, 861, 862,
863, 864, 865, 866, 867, 868,
869, 870, 871, 872, 873, 874,
875, 876, 877, 878, 879, 880,
881, 882, 883, 884, 885, 886,
887, 888, 889, 890, 891, 892,
893, 894, 895, 896, 897, 898,
899, 900, 901, 902, 903, 904,
905, 906, 907, 908, 909, 910,
911, 912, 913, 914, 915, 916,
917, 918, 919, 920, 921, 922,
923, 924, 925, 926, 927, 928,
929, 930, 931, 932, 933, 934,
935, 936, 937, 938, 939, 940,
941, 942, 943, 944, 945, 946,
947, 948, 949, 950, 951, 952,
953, 954, 955, 956, 957, 958,
959, 960, 961, 962, 963, 964,
965, 966, 967, 968, 969, 970,
971, 972, 973, 974, 975, 976,
977, 978, 979, 980, 981, 982,
983, 984, 985, 986, 987, 988,
989, 990, 991, 992, 993, 994,
995, 996, 997, 998, 999, 1000.



**ASSESSMENT
DIAGRAM**

NIPOMO MESA
SUPPLEMENTAL
ASSASSMENT DISTRICT
NO.1

NIPOMO COMMUNITY
SERVICES DISTRICT
STATE OF CALIFORNIA

- Legend**
-  ASSESSOR PARCEL
 -  ASSESSOR BOUNDARY
 -  DIAGRAM SHEET

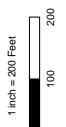

**SHEET:
54 OF 59**



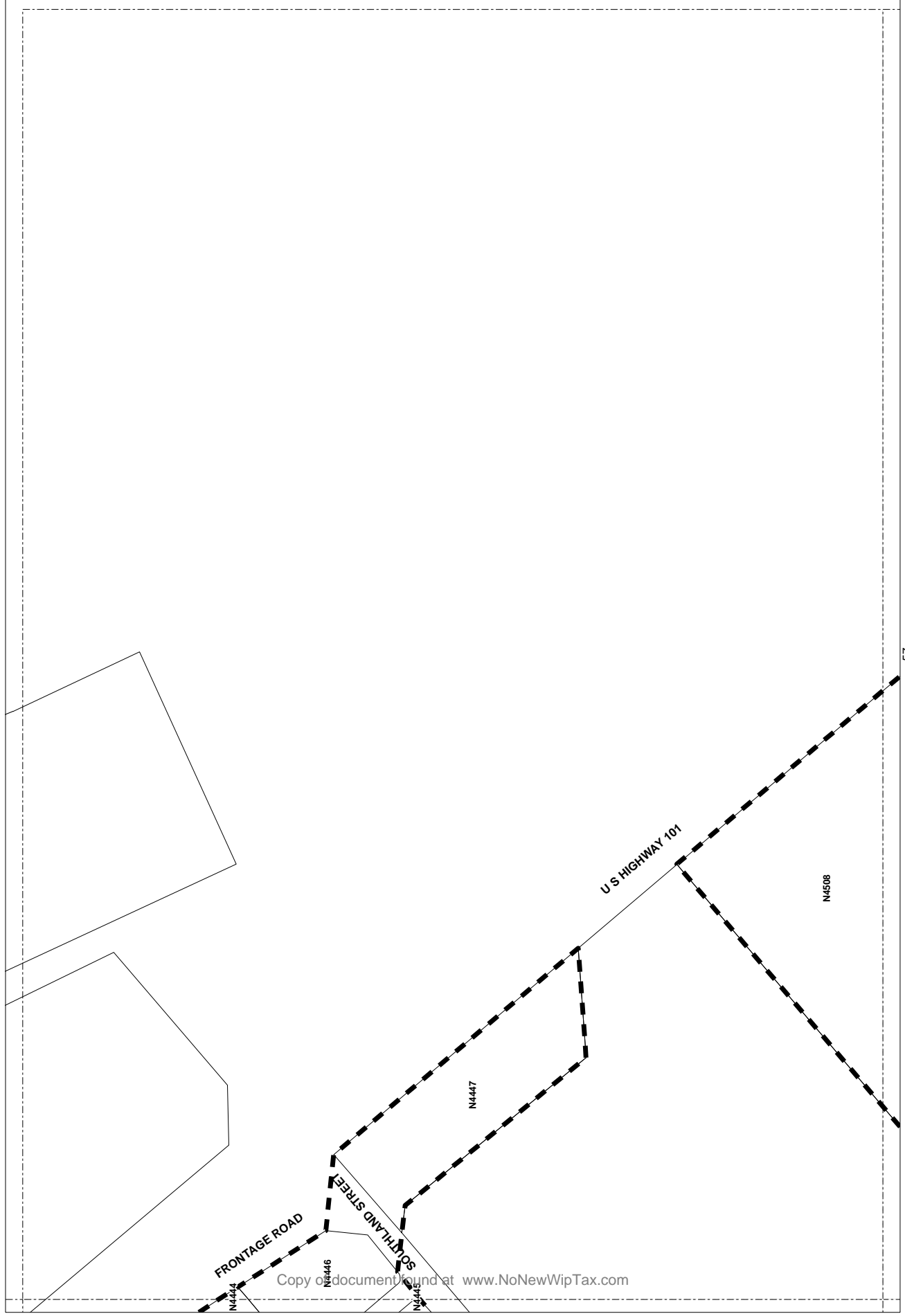

LOTS ON THIS SHEET ARE
BASED UPON THE 2017
MAP COUNTY OF SAN LUIS
OBISPO, CA; BK 080 PGS:
072, 078, 079, 081, 082, 083,
084, 085, 086, 087, 088, 089,
095, 101, 102, 103, 111, 121,
122, 123, 131, 132, 133, 134,
135, 140, 141, 142, 143, 144,
150, 151, 152, 153, 154, 155,
161, 162, 163, 164, 165, 166,
171, 172, 181, 182, 183, 184, 185,
191, 192, 193, 194, 195, 196,
201, 202, 203, 204, 205, 206,
211, 212, 213, 214, 215, 216,
221, 222, 223, 224, 225, 226,
231, 232, 233, 234, 235, 236,
241, 242, 243, 244, 245, 246,
251, 252, 253, 254, 255, 256,
261, 262, 263, 264, 265, 266,
271, 272, 273, 274, 275, 276,
281, 282, 283, 284, 285, 286,
291, 292, 293, 294, 295, 296,
301, 302, 303, 304, 305, 306,
311, 312, 313, 314, 315, 316,
321, 322, 323, 324, 325, 326,
331, 332, 333, 334, 335, 336,
341, 342, 343, 344, 345, 346,
351, 352, 353, 354, 355, 356,
361, 362, 363, 364, 365, 366,
371, 372, 373, 374, 375, 376,
381, 382, 383, 384, 385, 386,
391, 392, 393, 394, 395, 396,
401, 402, 403, 404, 405, 406,
411, 412, 413, 414, 415, 416,
421, 422, 423, 424, 425, 426,
431, 432, 433, 434, 435, 436,
441, 442, 443, 444, 445, 446,
451, 452, 453, 454, 455, 456,
461, 462, 463, 464, 465, 466,
471, 472, 473, 474, 475, 476,
481, 482, 483, 484, 485, 486,
491, 492, 493, 494, 495, 496,
501, 502, 503, 504, 505, 506,
511, 512, 513, 514, 515, 516,
521, 522, 523, 524, 525, 526,
531, 532, 533, 534, 535, 536,
541, 542, 543, 544, 545, 546,
551, 552, 553, 554, 555, 556,
561, 562, 563, 564, 565, 566,
571, 572, 573, 574, 575, 576,
577.



**ASSESSMENT
DIAGRAM**

NIPOMO MESA
SUPPLEMENTAL
ASSESSMENT DISTRICT
NO. 1
NIPOMO COMMUNITY
SERVICES DISTRICT
STATE OF CALIFORNIA

Legend

-  ASSESSOR PARCEL
-  ASSESSOR BOUNDARY
-  DIAGRAM SHEET



1 inch = 200 Feet

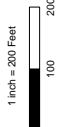

**SHEET:
55 OF 59**



LOTS ON THIS SHEET ARE
EASEMENTS TO THE
NIPOMO MESA SUPPLEMENTAL
ASSESSMENT DISTRICT
MAP COUNTY OF SAN LUIS
OBISPO, CA; BK 080 PGS:
072, 078, 079, 081, 082, 083,
084, 085, 086, 087, 088, 089,
090, 091, 092, 093, 094,
095, 101, 102, 103, 111, 121,
122, 123, 131, 132, 133, 134,
135, 141, 142, 143, 144,
151, 152, 161, 162, 163, 164,
165, 171, 172, 181, 182, 183,
184, 185, 191, 192, 193, 194,
195, 201, 202, 203, 204, 205,
206, 207, 208, 209, 210, 211,
212, 213, 214, 215, 216, 217,
218, 219, 220, 221, 222, 223,
224, 225, 226, 227, 228, 229,
230, 231, 232, 233, 234, 235,
236, 237, 238, 239, 240, 241,
242, 243, 244, 245, 246, 247,
248, 249, 250, 251, 252, 253,
254, 255, 256, 257, 258, 259,
260, 261, 262, 263, 264, 265,
266, 267, 268, 269, 270, 271,
272, 273, 274, 275, 276, 277,
278, 279, 280, 281, 282, 283,
284, 285, 286, 287, 288, 289,
290, 291, 292, 293, 294, 295,
296, 297, 298, 299, 300, 301,
302, 303, 304, 305, 306, 307,
308, 309, 310, 311, 312, 313,
314, 315, 316, 317, 318, 319,
320, 321, 322, 323, 324, 325,
326, 327, 328, 329, 330, 331,
332, 333, 334, 335, 336, 337,
338, 339, 340, 341, 342, 343,
344, 345, 346, 347, 348, 349,
350, 351, 352, 353, 354, 355,
356, 357, 358, 359, 360, 361,
362, 363, 364, 365, 366, 367,
368, 369, 370, 371, 372, 373, 374,
375, 376, 381, 382, 410, 411,
412, 413, 414, 415, 416, 417,
421, 431, 431, 440, 441, 442,
443, 444, 445, 446,
BK 092 PGS: 081, 082, 083,
084, 085, 086, 087, 088, 089,
090, 091, 092, 093, 094,
095, 096, 097, 098, 099,
100, 101, 102, 103, 104, 105,
106, 107, 108, 109, 110, 111,
112, 113, 114, 115, 116, 117,
118, 119, 120, 121, 122, 123,
124, 125, 126, 127, 128, 129,
130, 131, 132, 133, 134, 135,
136, 137, 138, 139, 140, 141,
142, 143, 144, 145, 146, 147,
148, 149, 150, 151, 152, 153,
154, 155, 156, 157, 158, 159,
160, 161, 162, 163, 164, 165,
166, 167, 168, 169, 170, 171,
172, 173, 174, 175, 176, 177,
178, 179, 180, 181, 182, 183,
184, 185, 186, 187, 188, 189,
190, 191, 192, 193, 194, 195,
196, 197, 198, 199, 200, 201,
202, 203, 204, 205, 206, 207,
208, 209, 210, 211, 212, 213,
214, 215, 216, 217, 218, 219,
220, 221, 222, 223, 224, 225,
226, 227, 228, 229, 230, 231,
232, 233, 234, 235, 236, 237,
238, 239, 240, 241, 242, 243,
244, 245, 246, 247, 248, 249,
250, 251, 252, 253, 254, 255,
256, 257, 258, 259, 260, 261,
262, 263, 264, 265, 266, 267,
268, 269, 270, 271, 272, 273,
274, 275, 276, 277, 278, 279,
280, 281, 282, 283, 284, 285,
286, 287, 288, 289, 290, 291,
292, 293, 294, 295, 296, 297,
298, 299, 300, 301, 302, 303,
304, 305, 306, 307, 308, 309,
310, 311, 312, 313, 314, 315,
316, 317, 318, 319, 320, 321,
322, 323, 324, 325, 326, 327,
328, 329, 330, 331, 332, 333,
334, 335, 336, 337, 338, 339,
340, 341, 342, 343, 344, 345,
346, 347, 348, 349, 350, 351,
352, 353, 354, 355, 356, 357,
358, 359, 360, 361, 362, 363,
364, 365, 366, 367, 368, 369,
370, 371, 372, 373, 374, 375,
376, 377, 378, 379, 380, 381,
382, 383, 384, 385, 386, 387,
388, 389, 390, 391, 392, 393,
394, 395, 396, 397, 398, 399,
400, 401, 402, 403, 404, 405,
406, 407, 408, 409, 410, 411,
412, 413, 414, 415, 416, 417,
418, 419, 420, 421, 422, 423,
424, 425, 426, 427, 428, 429,
430, 431, 432, 433, 434, 435,
436, 437, 438, 439, 440, 441,
442, 443, 444, 445, 446, 447,
448, 449, 450, 451, 452, 453,
454, 455, 456, 457, 458, 459,
460, 461, 462, 463, 464, 465,
466, 467, 468, 469, 470, 471,
472, 473, 474, 475, 476, 477,
478, 479, 480, 481, 482, 483,
484, 485, 486, 487, 488, 489,
490, 491, 492, 493, 494, 495,
496, 497, 498, 499, 500, 501,
502, 503, 504, 505, 506, 507,
508, 509, 510, 511, 512, 513,
514, 515, 516, 517, 518, 519,
520, 521, 522, 523, 524, 525,
526, 527, 528, 529, 530, 531,
532, 533, 534, 535, 536, 537,
538, 539, 540, 541, 542, 543,
544, 545, 546, 547, 548, 549,
550, 551, 552, 553, 554, 555, 556,
557, 558, 559, 560, 561, 562,
563, 564, 565, 566, 567, 568,
569, 570, 571, 572, 573, 574, 575,
576, 577.





**ASSESSMENT
DIAGRAM**

NIPOMO MESA
SUPPLEMENTAL
ASSASSMENT DISTRICT
NO.1

NIPOMO COMMUNITY
SERVICES DISTRICT
STATE OF CALIFORNIA

Legend

-  ASSESSMENT BOUNDARY
-  ASSESSOR PARCEL
-  DIAGRAM SHEET

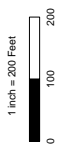

**SHEET:
57 OF 59**



LOTS ON THIS SHEET ARE
EASELMENTS TO THE
MAP COUNTY OF SAN LUIS
OBISPO, CA; BK 080 PGS:
072, 078, 079, 081, 082, 083,
084, 085, 086, 087, 088,
089, 090, 102, 103, 111, 121,
122, 123, 131, 132, 133, 134,
135, 146, 147, 148, 149, 150,
151, 152, 153, 154, 155,
156, 157, 158, 159, 160, 161,
162, 163, 164, 165, 166, 167,
168, 169, 170, 171, 172, 173,
174, 175, 176, 177, 178, 179,
180, 181, 182, 183, 184, 185,
186, 187, 188, 189, 190, 191,
192, 193, 194, 195, 196, 197,
198, 199, 200, 201, 202, 203,
204, 205, 206, 207, 208, 209,
210, 211, 212, 213, 214, 215,
216, 217, 218, 219, 220, 221,
222, 223, 243, 244, 246, 247,
248, 249, 250, 251, 252, 253,
254, 255, 256, 257, 258,
259, 260, 261, 262, 263, 264,
265, 266, 267, 268, 269, 270,
271, 272, 282, 283, 284, 285,
286, 287, 288, 289, 290, 291,
292, 293, 294, 295, 296, 297,
298, 299, 300, 301, 302, 303,
304, 305, 306, 307, 308, 309,
310, 311, 312, 313, 314, 315,
316, 317, 318, 319, 320, 321,
322, 323, 324, 325, 326, 327,
328, 329, 330, 331, 332, 333,
334, 335, 336, 337, 338, 339,
340, 341, 342, 343, 344, 345,
346, 347, 348, 349, 350, 351,
352, 353, 354, 355, 356, 357,
358, 359, 360, 361, 362, 363,
364, 365, 366, 367, 368, 369,
370, 371, 372, 373, 374, 375,
376, 377, 378, 379, 380, 381,
382, 383, 384, 385, 386, 387,
388, 389, 390, 391, 392, 393,
394, 395, 396, 397, 398, 399,
400, 401, 402, 403, 404, 405,
406, 407, 408, 409, 410, 411,
412, 413, 414, 415, 416, 417,
418, 419, 420, 421, 422, 423,
424, 425, 426, 427, 428, 429,
430, 431, 432, 433, 434, 435,
436, 437, 438, 439, 440, 441,
442, 443, 444, 445, 446,
447, 448, 449, 450, 451, 452,
453, 454, 455, 456, 457, 458,
459, 460, 461, 462, 463, 464,
465, 466, 467, 468, 469, 470,
471, 472, 473, 474, 475, 476,
477, 478, 479, 480, 481, 482,
483, 484, 485, 486, 487, 488,
489, 490, 491, 492, 493, 494,
495, 496, 497, 498, 499, 500,
501, 502, 503, 504, 505, 506,
507, 508, 509, 510, 511, 512,
513, 514, 515, 516, 517, 518,
519, 520, 521, 522, 523, 524,
525, 526, 527, 528, 529, 530,
531, 532, 533, 534, 535, 536,
537, 538, 539, 540, 541, 542,
543, 544, 545, 546, 547, 548,
549, 550, 551, 552, 553, 554,
555, 556, 557, 558, 559, 560,
561, 562, 563, 564, 565, 566,
567, 568, 569, 570, 571, 572,
573, 574, 575, 576, 577.

54

U S HIGHWAY 101

N4508

N4507

53



99

**ASSESSMENT
DIAGRAM**

NIPOMO MESA
SUPPLEMENTAL
ASSESSMENT DISTRICT
NO.1

NIPOMO COMMUNITY
SERVICES DISTRICT
STATE OF CALIFORNIA

Legend

-  ASSM BOUNDARY
-  ASSESSOR PARCEL
-  DIAGRAM SHEET



1 inch = 200 Feet

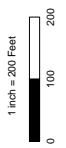

**SHEET:
59 OF 59**



LOTS ON THIS SHEET ARE
EASELMENTS TO THE
MAP COUNTY OF SAN LUIS
OBISPO, CA; BK 080 PGS:
072, 078, 079, 081, 082, 083,
084, 085, 086, 087, 088, 089,
095, 101, 102, 103, 111, 121,
122, 123, 131, 132, 133, 134,
135, 146, 147, 148, 149, 150,
151, 152, 153, 154, 155, 156,
157, 158, 159, 160, 161,
162, 163, 164, 165, 166,
167, 168, 169, 170, 171,
172, 173, 174, 175, 176,
177, 178, 179, 180, 181,
182, 183, 184, 185, 186,
187, 188, 189, 190, 191,
192, 193, 194, 195, 196,
197, 198, 199, 200, 201,
202, 203, 243, 244, 246, 247,
248, 249, 250, 251, 252,
253, 254, 255, 256, 257,
258, 259, 260, 261, 262,
263, 264, 265, 266, 267,
268, 269, 270, 271, 272,
273, 274, 275, 276, 281,
282, 283, 284, 285, 286,
287, 288, 289, 290, 291,
292, 293, 294, 295, 296,
297, 298, 299, 300, 301,
302, 303, 304, 311, 321, 331,
341, 351, 361, 371, 381, 391,
395, 396, 463, 510, 512, 513,
531, 532, 533, 534, 551, 570,
571, 572, 573, 574, 575, 576,
577.



Nipomo Mesa Supplemental Water Project Assessment District No. 1

Nipomo Community Services District
State of California



Part V

Assessment Diagram

For
Rural Water Company

February 2012 Draft





**ASSESSMENT
DIAGRAM**

NIPOMO MESA
SUPPLEMENTAL
MAP COUNTY OF SAN LUIS
ASSESSMENT DISTRICT
NO. 1

NIPOMO COMMUNITY
SERVICES DISTRICT
STATE OF CALIFORNIA

Legend

-  ASSESSOR PARCEL
-  ASSESSOR BOUNDARY
-  DIAGRAM SHEET

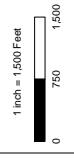

**SHEET:
1 OF 28**

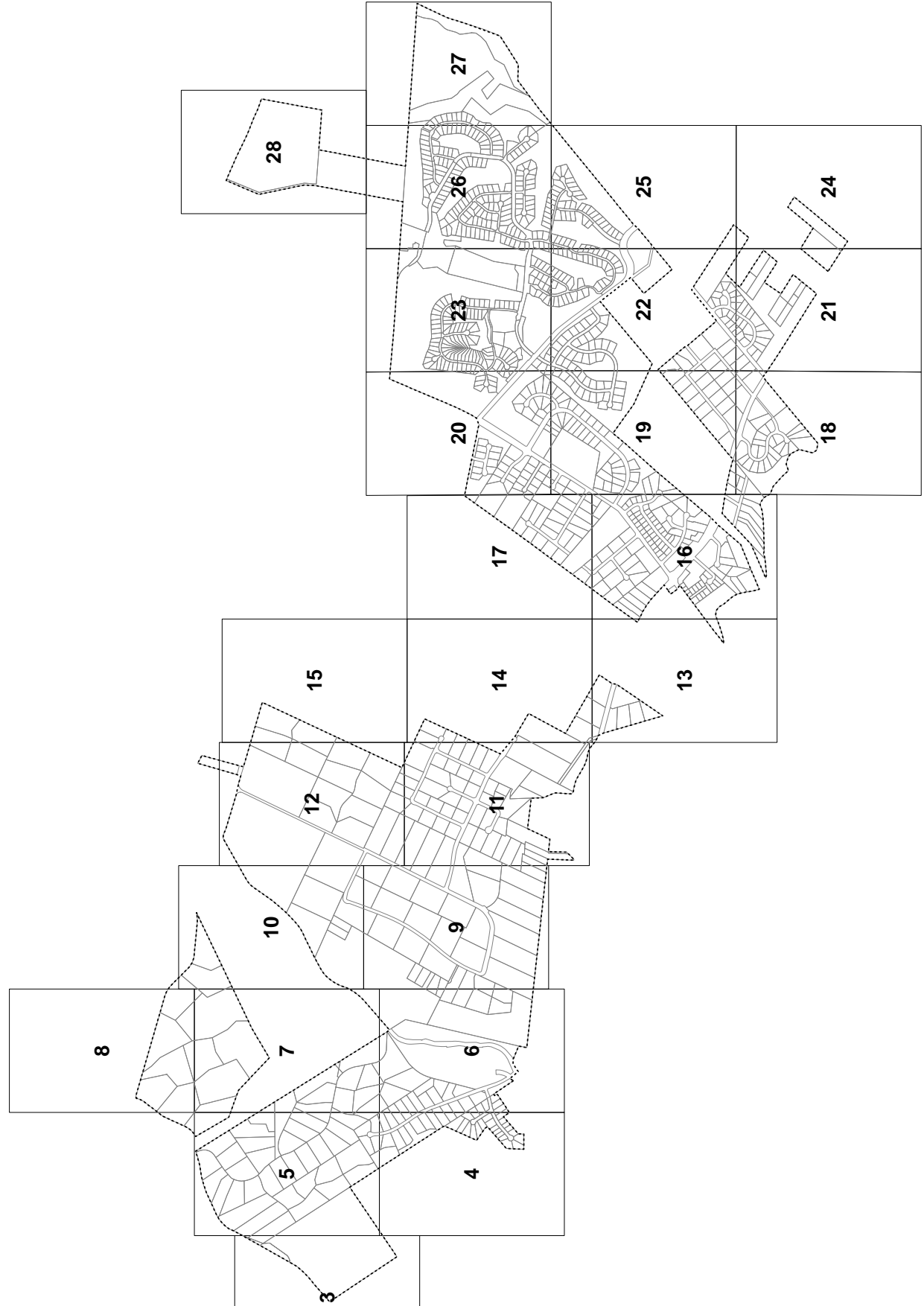

LOTS ON THIS SHEET ARE
BASED ON ASSESSORS
MAP COUNTY OF SAN LUIS
ASSESSMENT DISTRICT NO. 1,
041, 042, 051, 061, 150, 151,
160, 161, 162, 164, 165, 171,
181, 202, 203, 204, 211, 241,
251, 252, 253, 254, 255,
364, 365, 380, 381, 392, 393,
400, 401, 402, 403, 404, 405,
406, 407, 408, 409, 410, 411,
412.

ASSESSMENT NUMBER INDEX



<u>SHEET NUMBER:</u>	<u>ASSESSMENT NUMBER:</u>
SHEET 3	0001-0003
SHEET 4	0004-0039
SHEET 5	0040-0078
SHEET 6	0079-0105
SHEET 7	0106-0120
SHEET 8	0121-0125
SHEET 9	0126-0154
SHEET 10	0155-0162
SHEET 11	0163-0216
SHEET 12	0217-0234
SHEET 13	0235-0241
SHEET 14	0242-0246
SHEET 15	0247-0248
SHEET 16	0249-0374
SHEET 17	0375-0399
SHEET 18	0400-0431
SHEET 19	0432-0513
SHEET 20	0514-0569
SHEET 21	0570-0599
SHEET 22	0600-0700
SHEET 23	0701-0835
SHEET 24	0836
SHEET 25	0837-0881
SHEET 26	0882-1069
SHEET 27	1070-1083
SHEET 28	1084-1085

**ASSESSMENT
DIAGRAM**

NIPOMO MESA
SUPPLEMENTAL
SERVICES DISTRICT
ASSESSMENT DISTRICT
NO.1

NIPOMO COMMUNITY
SERVICES DISTRICT
STATE OF CALIFORNIA

Legend

-  ASSESSOR PARCEL
-  ASSESSOR PARCEL
-  ASSESSOR PARCEL

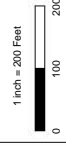

**SHEET:
3 OF 28**

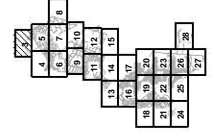

LOTS ON THIS SHEET ARE
BASED ON ASSESSORS
MAP COUNTY OF SAN LUIS
OBISPO COUNTY, CALIFORNIA
0481, 042, 051, 061, 150, 151,
160, 161, 162, 164, 165, 171,
181, 202, 203, 204, 211, 241,
242, 243, 244, 245, 246,
364, 365, 380, 381, 382, 383,
400, 401, 402, 403, 404, 405,
406, 407, 408, 409, 410, 411,
412

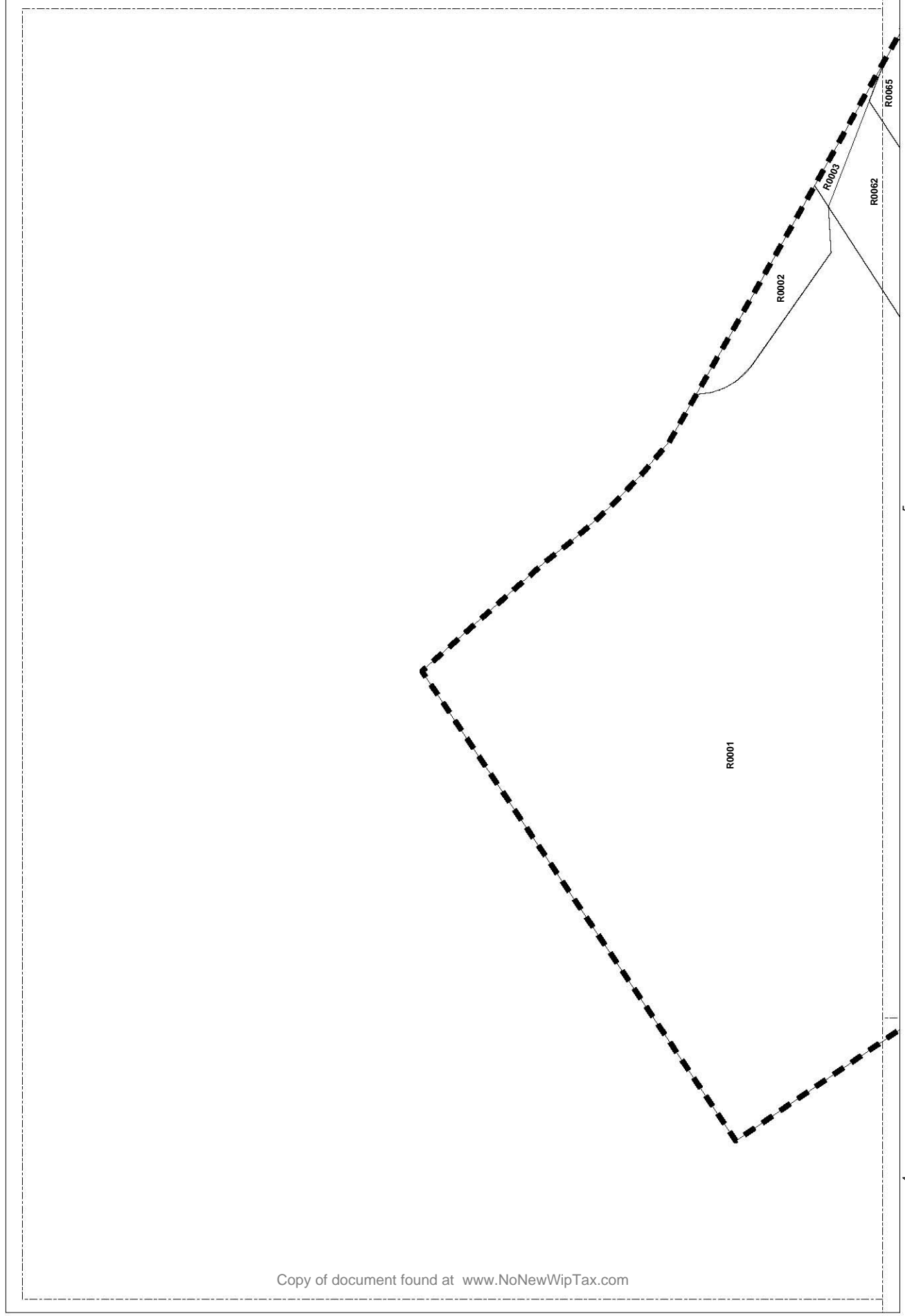





**ASSESSMENT
DIAGRAM**

NIPOMO MESA
SUPPLEMENTAL
MAPPING DISTRICT
ASSESSMENT DISTRICT
NO.1

NIPOMO COMMUNITY
SERVICES DISTRICT
STATE OF CALIFORNIA

Legend

-  ASSESSOR PARCEL
-  ASSESSOR BOUNDARY
-  ASSESSOR PARCEL
-  DIAGRAM SHEET

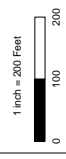

**SHEET:
4 OF 28**



LOTS ON THIS SHEET ARE
BASED ON ASSESSORS
MAP COUNTY OF SAN LUIS
OBISPO COUNTY, CALIFORNIA
041,042,051,061,061,150,151,
160,161,162,164,165,171,
181,202,203,204,211,241,
242,243,244,245,246,
364,365,380,381,382,383,
400,401,402,403,404,405,
406,407,408,409,410,411,
412.

3

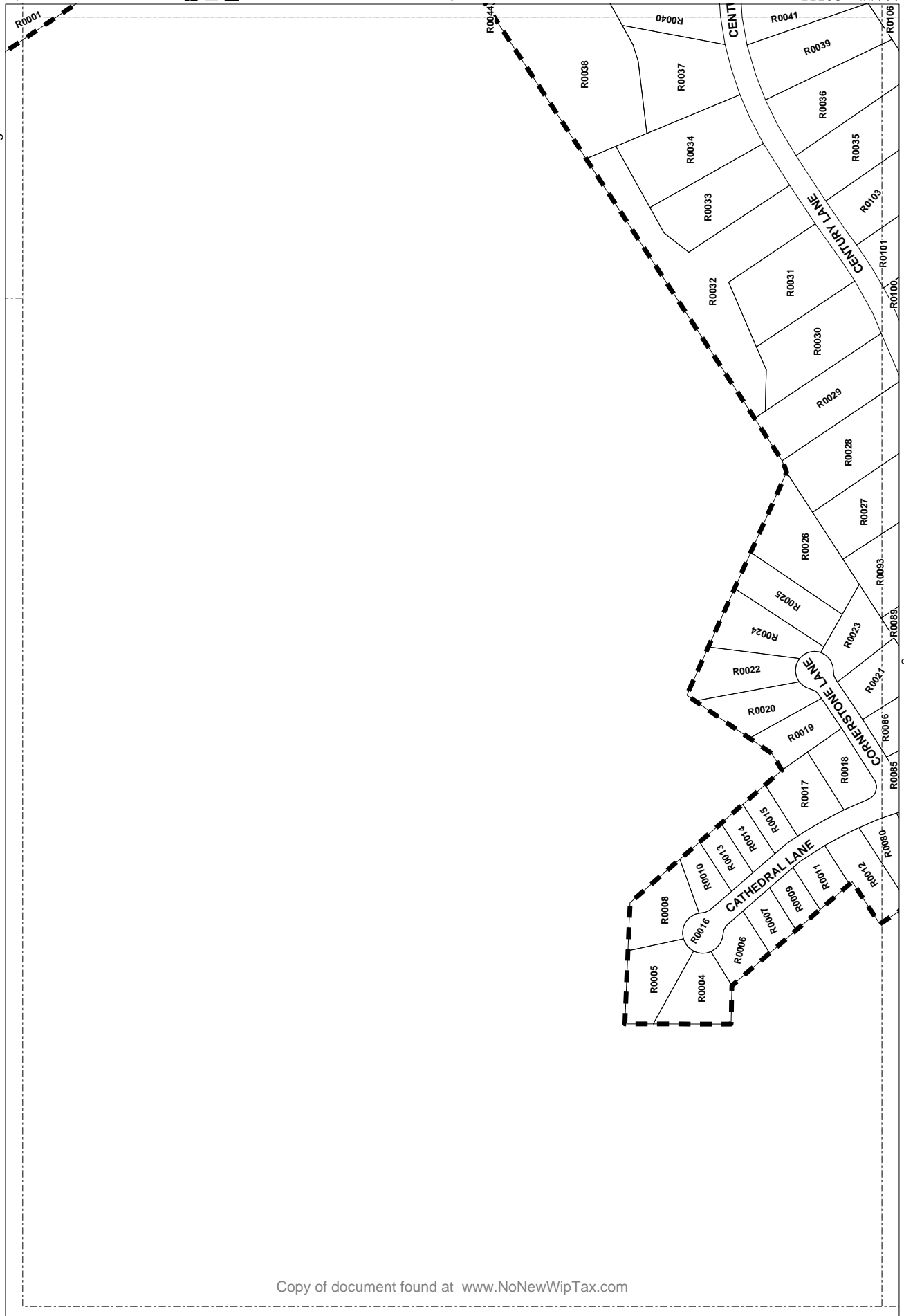



6

**ASSESSMENT
DIAGRAM**

NIPOMO MESA
SUPPLEMENTAL
ASSESSMENT DISTRICT
NO.1

NIPOMO COMMUNITY
SERVICES DISTRICT
STATE OF CALIFORNIA

- Legend**
-  ASSESSOR PARCEL
 -  ASSESSOR PARCEL
 -  ASSESSOR PARCEL

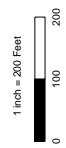

**SHEET:
5 OF 28**





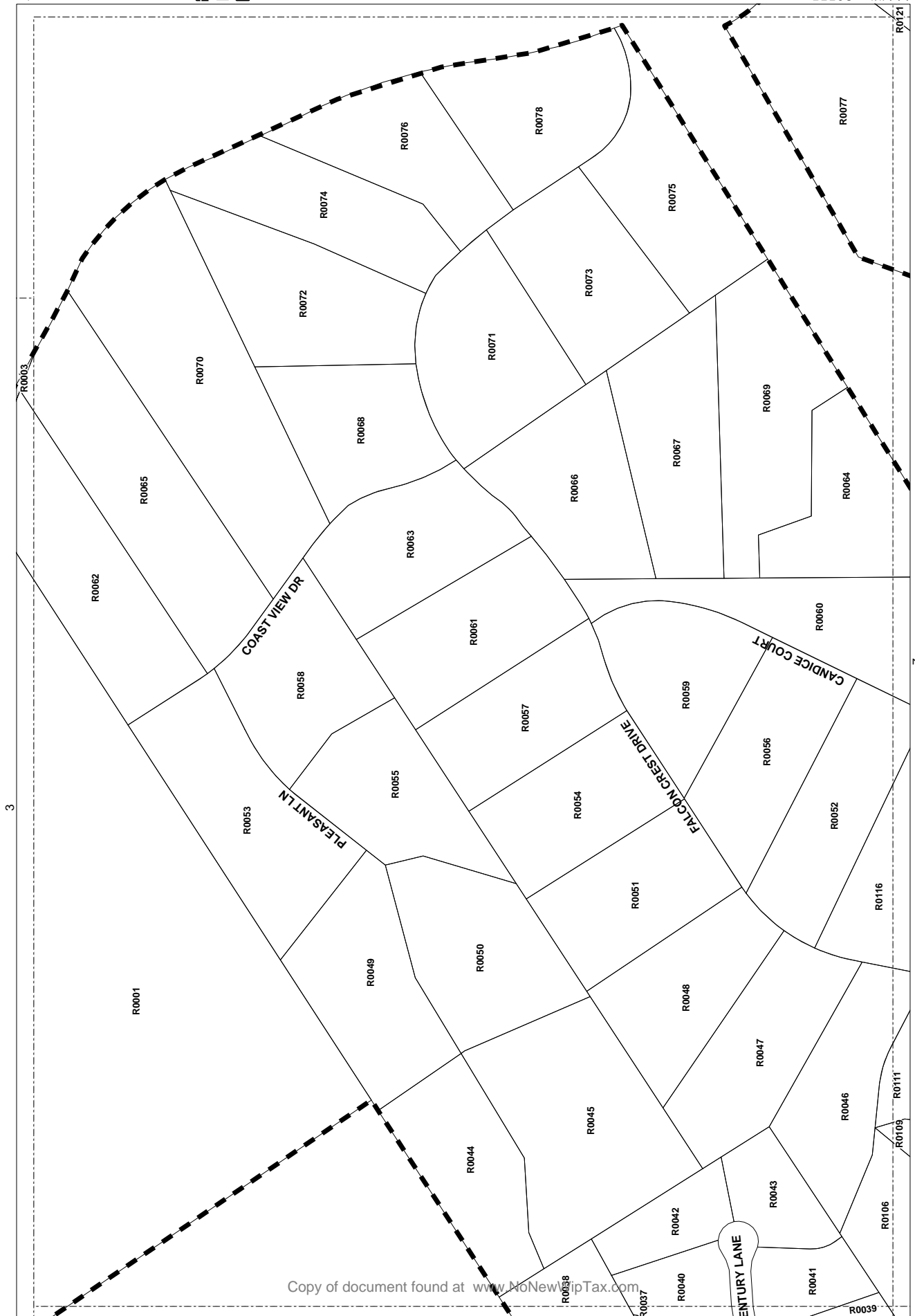

































LOTS ON THIS SHEET ARE
BASED ON ASSESSORS
MAP COUNTY OF SAN LUIS
OBSERVED 05/05/2011
041, 042, 051, 061, 150, 151,
160, 161, 162, 164, 165, 171,
181, 202, 203, 204, 211, 241,
242, 243, 244, 245, 246,
364, 365, 380, 381, 382, 383,
400, 401, 402, 403, 404, 405,
406, 407, 408, 409, 410, 411,
412.



**ASSESSMENT
DIAGRAM**

NIPOMO MESA
SUPPLEMENTAL
ASSESSMENT DISTRICT
NO. 1

NIPOMO COMMUNITY
SERVICES DISTRICT
STATE OF CALIFORNIA

- Legend**
-  ASSESSOR PARCEL
 -  ASSESSOR PARCEL
 -  ASSESSOR PARCEL
 -  ASSESSOR PARCEL
 -  ASSESSOR PARCEL
 -  ASSESSOR PARCEL
 -  ASSESSOR PARCEL
 -  ASSESSOR PARCEL
 -  ASSESSOR PARCEL
 -  ASSESSOR PARCEL
 -  ASSESSOR PARCEL
 -  ASSESSOR PARCEL
 -  ASSESSOR PARCEL
 -  ASSESSOR PARCEL
 -  ASSESSOR PARCEL
 -  ASSESSOR PARCEL
 -  ASSESSOR PARCEL
 -  ASSESSOR PARCEL
 -  ASSESSOR PARCEL
 -  ASSESSOR PARCEL
 -  ASSESSOR PARCEL
 -  ASSESSOR PARCEL
 -  ASSESSOR PARCEL
 -  ASSESSOR PARCEL
 -  ASSESSOR PARCEL
 -  ASSESSOR PARCEL
 -  ASSESSOR PARCEL
 -  ASSESSOR PARCEL
 -  ASSESSOR PARCEL
 -  ASSESSOR PARCEL
 -  ASSESSOR PARCEL
 -  ASSESSOR PARCEL
 -  ASSESSOR PARCEL
 -  ASSESSOR PARCEL
 -  ASSESSOR PARCEL
 -  ASSESSOR PARCEL
 -  ASSESSOR PARCEL



1 inch = 200 Feet
0 100 200

**SHEET:
6 OF 28**









LOTS ON THIS SHEET ARE
BASED ON ASSESSORS
MAP COUNTY OF SAN LUIS
OBSERVED BY THE ASSESSOR
ON 04/10/2003. THE LOTS ARE:
160, 161, 162, 164, 165, 171,
181, 202, 203, 204, 211, 241,
242, 243, 244, 245, 246,
364, 365, 380, 381, 382, 383,
400, 401, 402, 403, 404, 405,
406, 407, 408, 409, 410, 411,
412.



**ASSESSMENT
DIAGRAM**

NIPOMO MESA
SUPPLEMENTAL
MAP DISTRICT
ASSESSMENT DISTRICT
NO. 1

NIPOMO COMMUNITY
SERVICES DISTRICT
STATE OF CALIFORNIA

- Legend**
-  ASSESSOR PARCEL
 -  ASSESSOR BOUNDARY
 -  ASSESSOR PARCEL
 -  ASSESSOR BOUNDARY
 -  ASSESSOR PARCEL
 -  ASSESSOR BOUNDARY

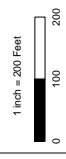

**SHEET:
7 OF 28**



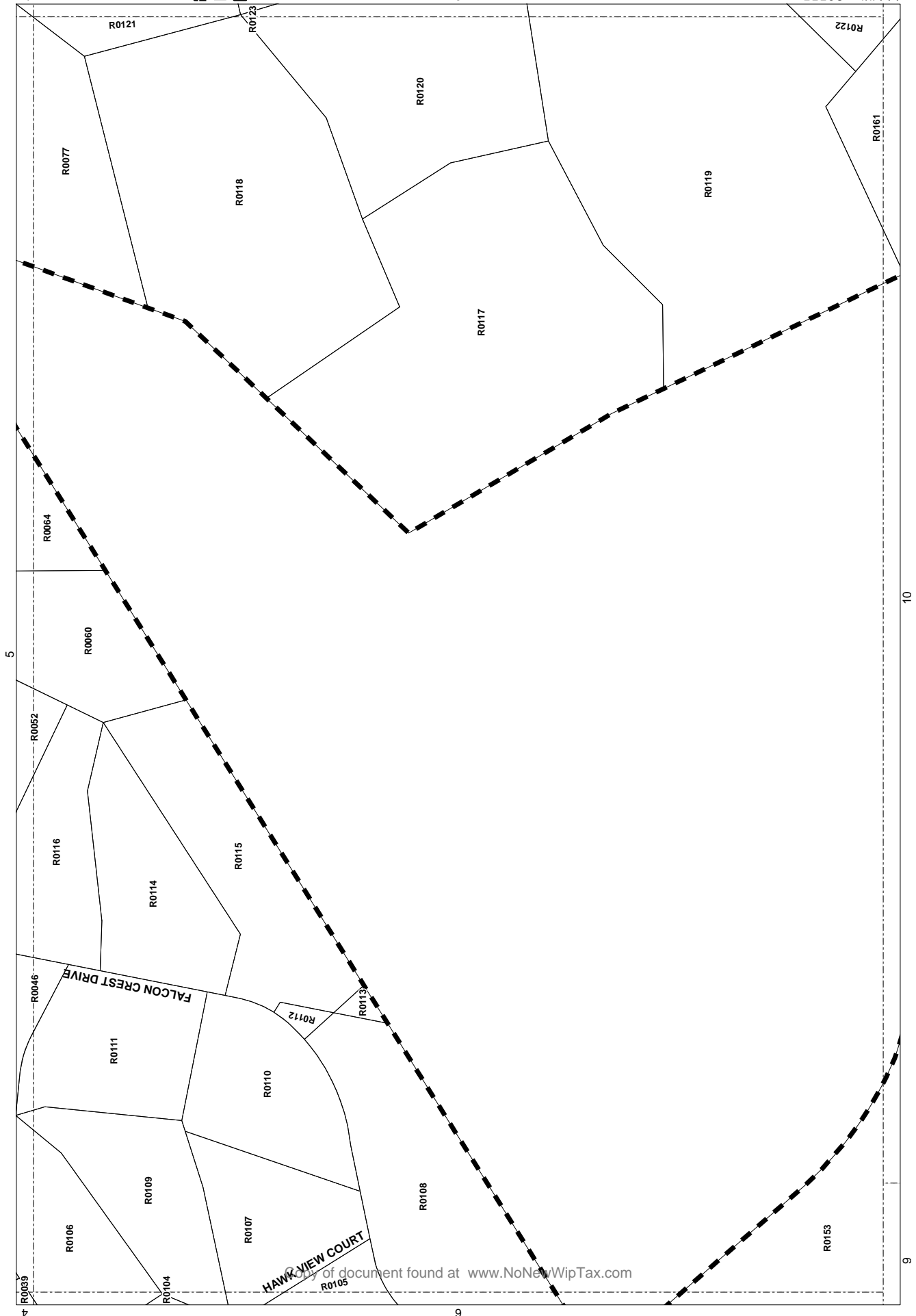

LOTS ON THIS SHEET ARE
BASED ON ASSESSORS
MAP COUNTY OF SAN LUIS
OBIPOLO DISTRICT NO. 1
041, 042, 051, 061, 150, 151,
160, 161, 162, 164, 165, 171,
181, 202, 203, 204, 211, 241,
242, 243, 244, 245, 246,
364, 365, 380, 381, 382, 383,
400, 401, 402, 403, 404, 405,
406, 407, 408, 409, 410, 411,
412.



ASSESSMENT DIAGRAM

NIPOMO MESA
SUPPLEMENTAL
ASSESSMENT DISTRICT
NO.1

NIPOMO COMMUNITY
SERVICES DISTRICT
STATE OF CALIFORNIA

- Legend**
-  ASSM BOUNDARY
 -  ASSESSOR PARCEL
 -  DIAGRAM SHEET

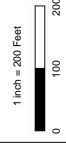

SHEET:
8 OF 28



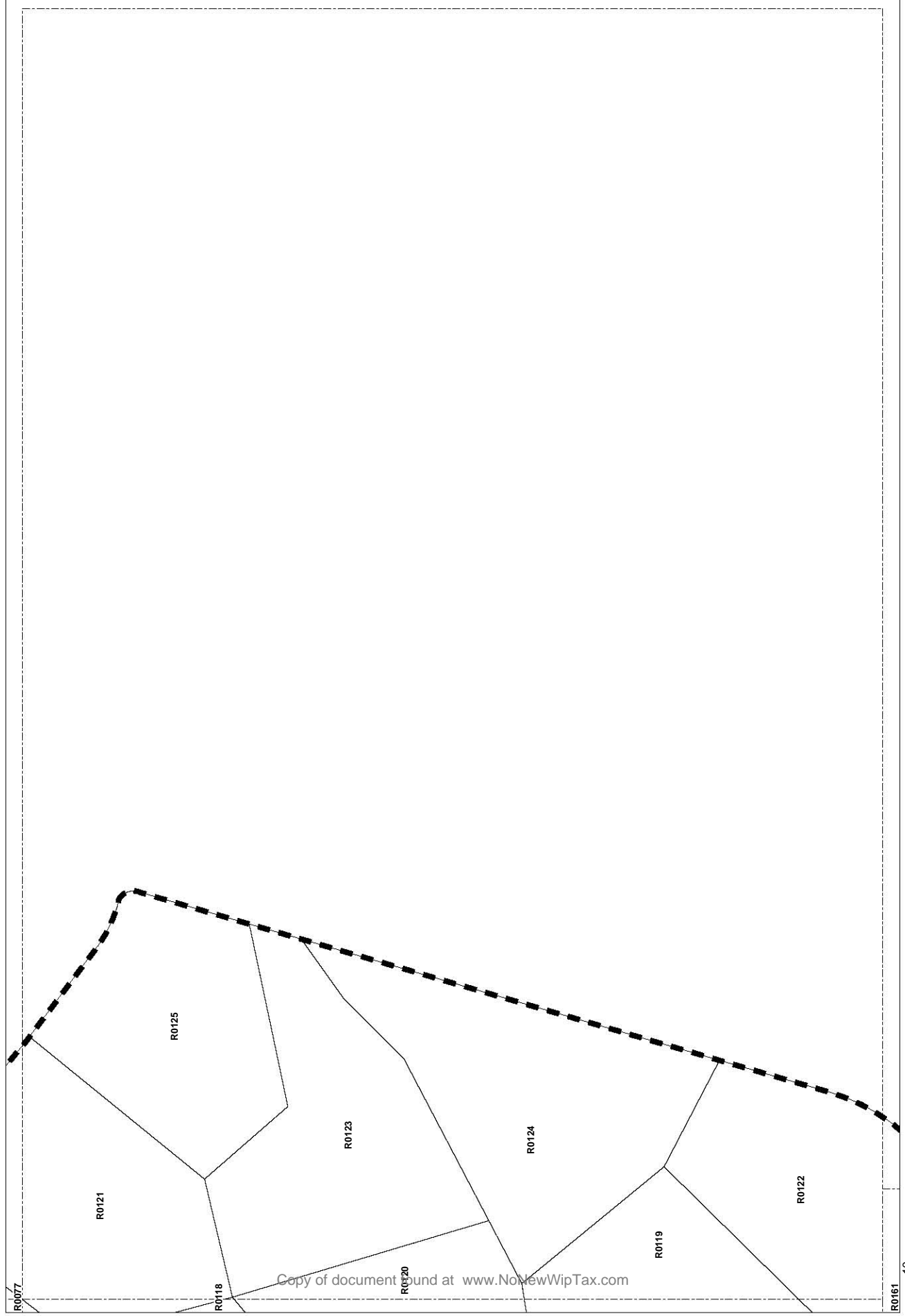

LOTS ON THIS SHEET ARE
BASED ON ASSESSORS
MAP COUNTY OF SAN LUIS
OBISPO COUNTY, 1992-93
0481 042 051 061 150 151
160 161 162 164 165 171
181 202 203 204 211 241
242 243 244 245 246
364 365 380 381 382 383
400 401 402 403 404 405
406 407 408 409 410 411
412



**ASSESSMENT
DIAGRAM**

NIPOMO MESA
SUPPLEMENTAL
ASSESSMENT DISTRICT
NO. 1

NIPOMO COMMUNITY
SERVICES DISTRICT
STATE OF CALIFORNIA

- Legend**
-  ASSESSOR PARCEL
 -  ASSESSOR PARCEL
 -  ASSESSOR PARCEL

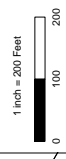

10

**SHEET:
9 OF 28**

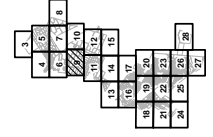

LOTS ON THIS SHEET ARE
BASED ON ASSESSORS
MAP COUNTY OF SAN LUIS
OBISPO COUNTY 1992-2011
041, 042, 051, 061, 150, 151,
160, 161, 162, 164, 165, 171,
181, 202, 203, 204, 211, 241,
242, 243, 244, 245, 246,
364, 365, 380, 381, 382, 383,
400, 401, 402, 403, 404, 405,
406, 407, 408, 409, 410, 411,
412.

7

6

12





11



**ASSESSMENT
DIAGRAM**

NIPOMO MESA
SUPPLEMENTAL
SERVICES DISTRICT
ASSESSMENT DISTRICT
NO.1

NIPOMO COMMUNITY
SERVICES DISTRICT
STATE OF CALIFORNIA

- Legend**
-  ASSESSOR PARCEL
 -  ASSESSOR PARCEL
 -  ASSESSOR PARCEL
 -  ASSESSOR PARCEL

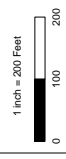

**SHEET:
10 OF 28**

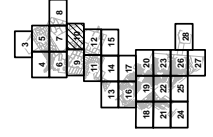

LOTS ON THIS SHEET ARE
BASED ON ASSESSORS
MAP COUNTY OF SAN LUIS
OBSOLETE MAPS: 04/19/21,
04/19/22, 05/19/21,
160, 161, 162, 164, 165, 171,
181, 202, 203, 204, 211, 241,
242, 243, 244, 245, 246,
364, 365, 380, 381, 382, 383,
400, 401, 402, 403, 404, 405,
406, 407, 408, 409, 410, 411,
412.

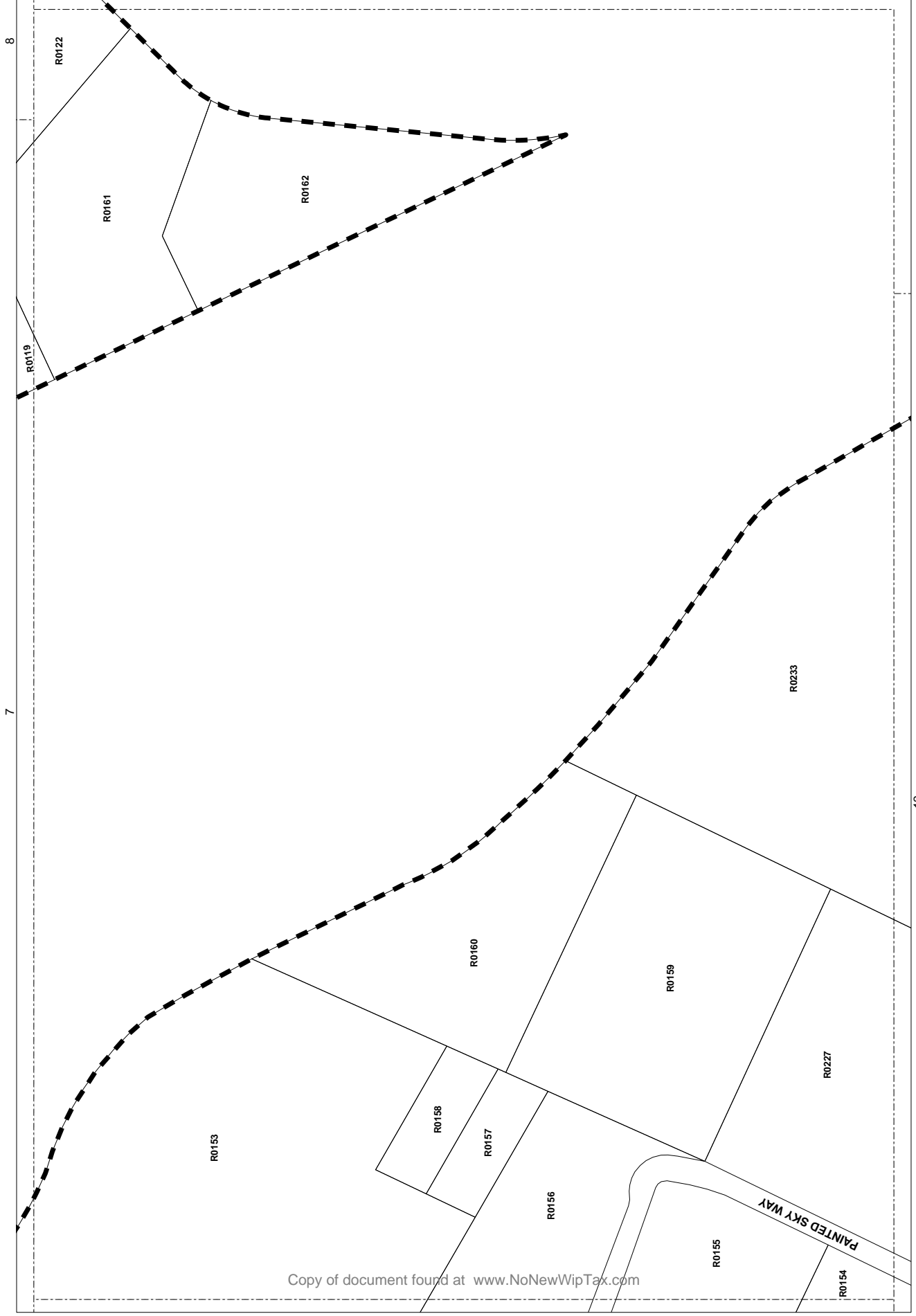





**ASSESSMENT
DIAGRAM**

NIPOMO MESA
SUPPLEMENTAL
ASSESSMENT DISTRICT
NO. 1

NIPOMO COMMUNITY
SERVICES DISTRICT
STATE OF CALIFORNIA

Legend

-  ASSESSOR PARCEL
-  ASSESSOR PARCEL
-  ASSESSOR PARCEL
-  DIAGRAM SHEET

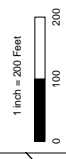

12

**SHEET:
11 OF 28**



LOTS ON THIS SHEET ARE
BASED ON ASSESSORS
MAP COUNTY OF SAN LUIS
OBISPO COUNTY, CALIFORNIA
041, 042, 051, 061, 062, 063,
160, 161, 162, 164, 165, 171,
181, 202, 203, 204, 211, 241,
242, 243, 244, 245, 246,
364, 365, 380, 381, 382, 383,
400, 401, 402, 403, 404, 405,
406, 407, 408, 409, 410, 411,
412

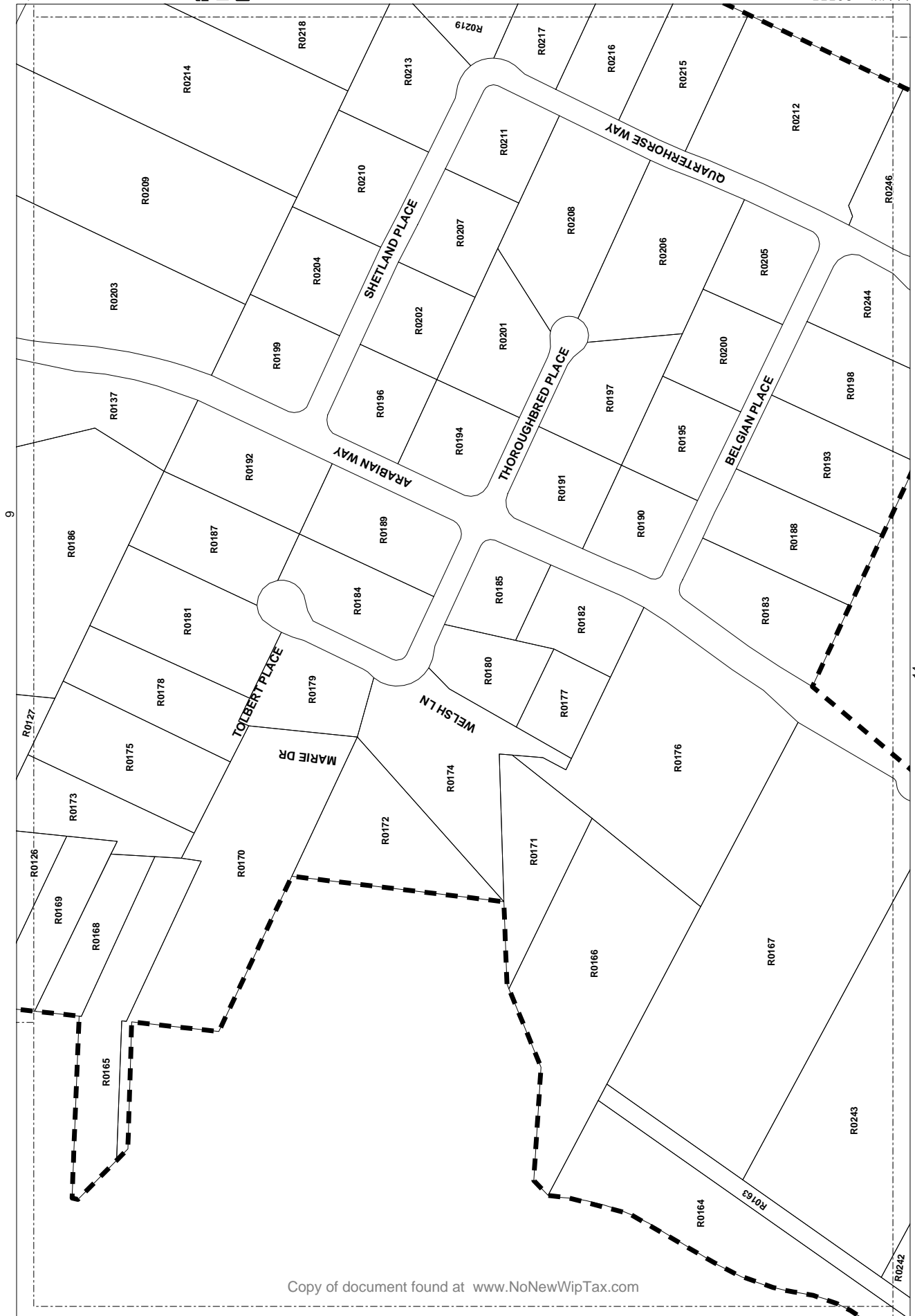





9

14

**ASSESSMENT
DIAGRAM**

NIPOMO MESA
SUPPLEMENTAL
ASSASSMENT DISTRICT
NO.1

NIPOMO COMMUNITY
SERVICES DISTRICT
STATE OF CALIFORNIA

- Legend**
-  ASSESSOR PARCEL
 -  ASSESSOR PARCEL
 -  ASSESSOR PARCEL
 -  ASSESSOR PARCEL
 -  ASSESSOR PARCEL

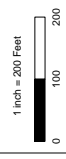

**SHEET:
12 OF 28**



LOTS ON THIS SHEET ARE
BASED ON ASSESSORS
MAP COUNTY OF SAN LUIS
OBSOLETE MAP SHEET NO.
0481 042 051 061 150 151
160, 161, 162, 164, 165, 171,
181, 202, 203, 204, 211, 241,
242, 243, 244, 245, 246,
364, 365, 380, 381, 382, 383,
400, 401, 402, 403, 404, 405,
406, 407, 408, 409, 410, 411,
412.

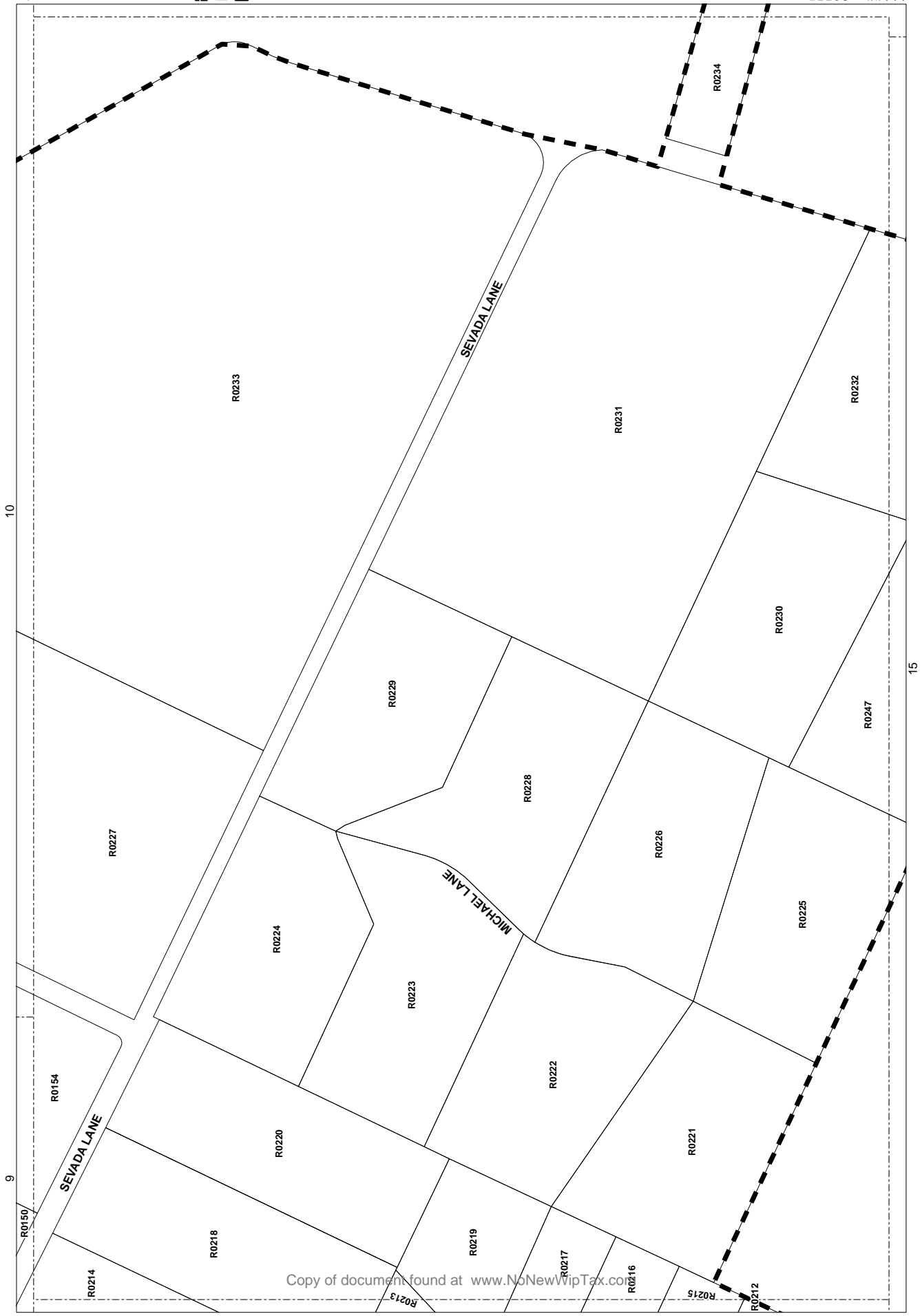





**ASSESSMENT
DIAGRAM**

NIPOMO MESA
SUPPLEMENTAL
SERVICES DISTRICT
ASSESSMENT DISTRICT
NO.1

NIPOMO COMMUNITY
SERVICES DISTRICT
STATE OF CALIFORNIA

Legend

-  ASSESSOR PARCEL
-  ASSESSOR PARCEL
-  ASSESSOR PARCEL
-  DIAGRAM SHEET

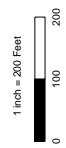

14

**SHEET:
13 OF 28**





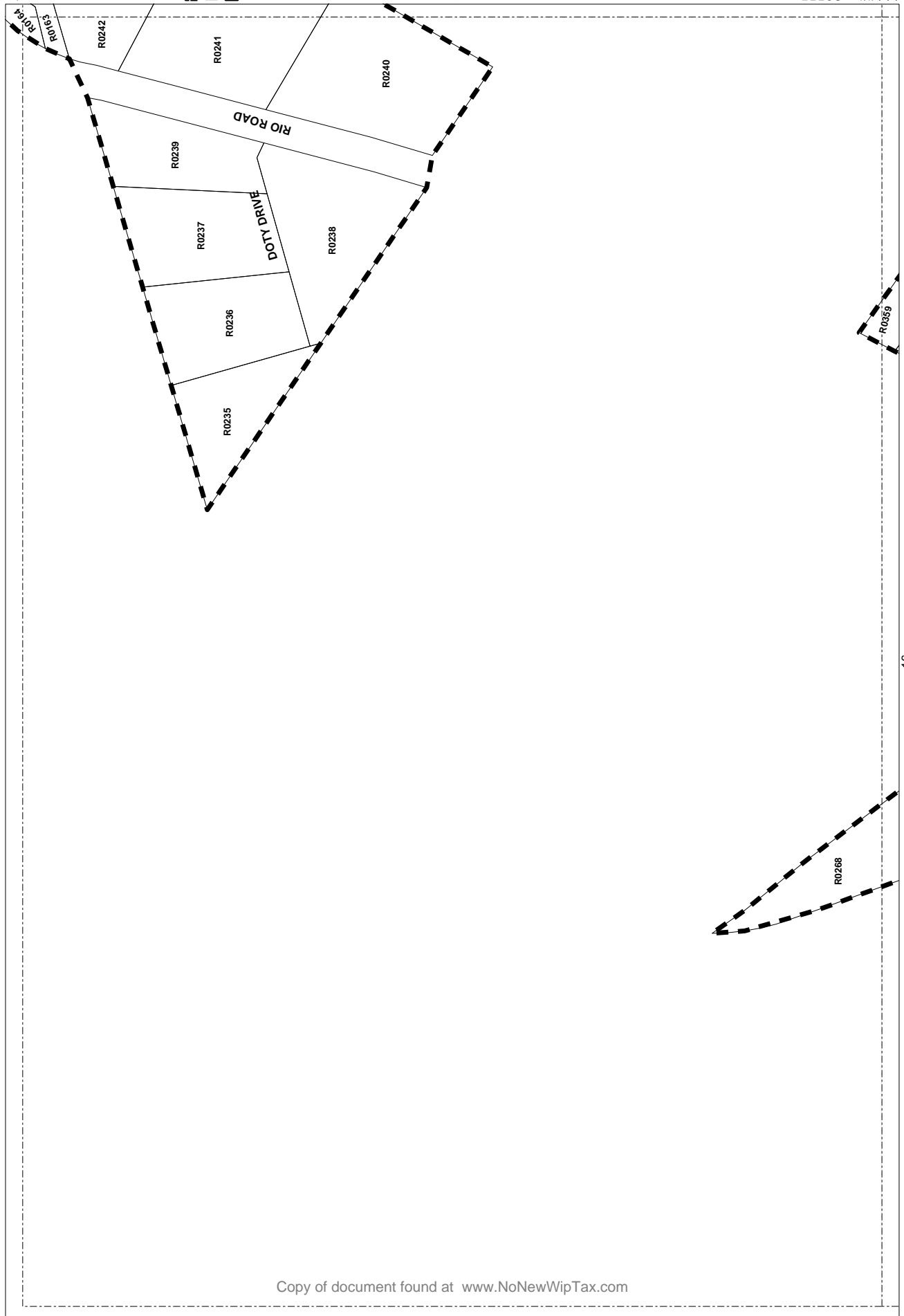

LOTS ON THIS SHEET ARE
BASED ON ASSESSORS
MAP COUNTY OF SAN LUIS
OBISPO COUNTY, 1992
0481, 042, 051, 061, 150, 151,
160, 161, 162, 164, 165, 171,
181, 202, 203, 204, 211, 241,
242, 243, 244, 245, 246,
364, 365, 380, 381, 382, 383,
400, 401, 402, 403, 404, 405,
406, 407, 408, 409, 410, 411,
412.



**ASSESSMENT
DIAGRAM**

NIPOMO MESA
SUPPLEMENTAL
ASSESSMENT DISTRICT
NO.1

NIPOMO COMMUNITY
SERVICES DISTRICT
STATE OF CALIFORNIA

- Legend**
-  ASSESSOR PARCEL
 -  ASSESSOR PARCEL
 -  ASSESSOR PARCEL
 -  ASSESSOR PARCEL

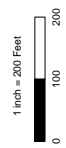

LOTS ON THIS SHEET ARE
BASED ON ASSESSORS
MAP COUNTY OF SAN LUIS
OCEANOGRAPHIC DISTRICT
0481042 051 061 150 151
160, 161, 162, 164, 165, 171,
181, 202, 203, 204, 211, 241,
242, 243, 244, 245, 246,
364, 365, 380, 381, 382, 383,
400, 401, 402, 403, 404, 405,
406, 407, 408, 409, 410, 411,
412.

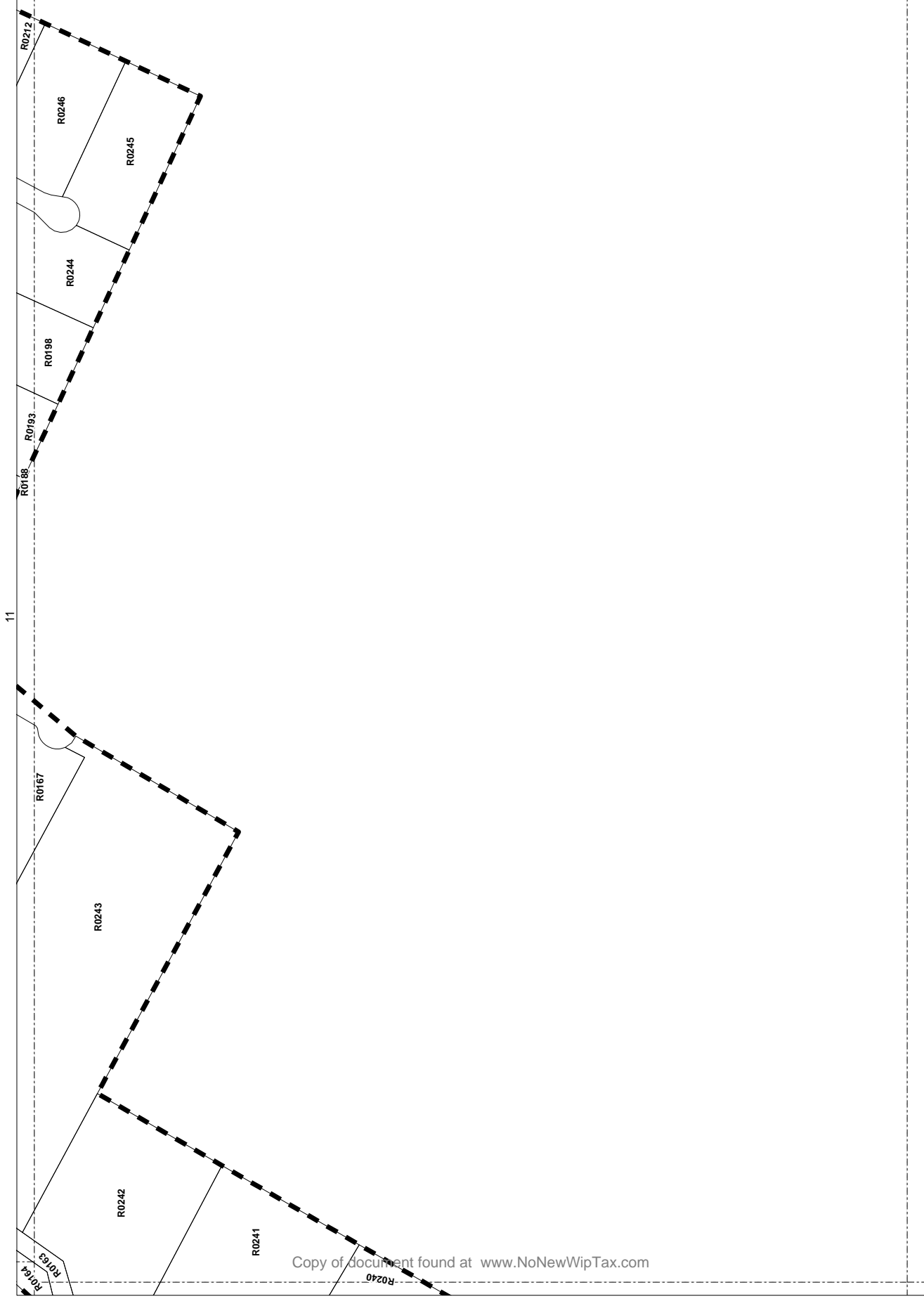





Copy of document found at www.NoNewWipTax.com

**ASSESSMENT
DIAGRAM**

NIPOMO MESA
SUPPLEMENTAL
SERVICES DISTRICT
ASSESSMENT DISTRICT
NO.1

NIPOMO COMMUNITY
SERVICES DISTRICT
STATE OF CALIFORNIA

Legend

-  ASSESSOR PARCEL
-  ASSESSOR PARCEL
-  ASSESSOR PARCEL
-  ASSESSOR PARCEL

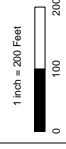

**SHEET:
15 OF 28**

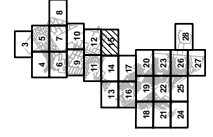

LOTS ON THIS SHEET ARE
BASED ON ASSESSORS
MAP COUNTY OF SAN LUIS
OCEANOGRAPHIC DISTRICT
0481 042 051 061 150 151
160, 161, 162, 164, 165, 171,
181, 202, 203, 204, 211, 241,
242, 243, 244, 245, 246,
364, 365, 380, 381, 382, 383,
400, 401, 402, 403, 404, 405,
406, 407, 408, 409, 410, 411,
412.

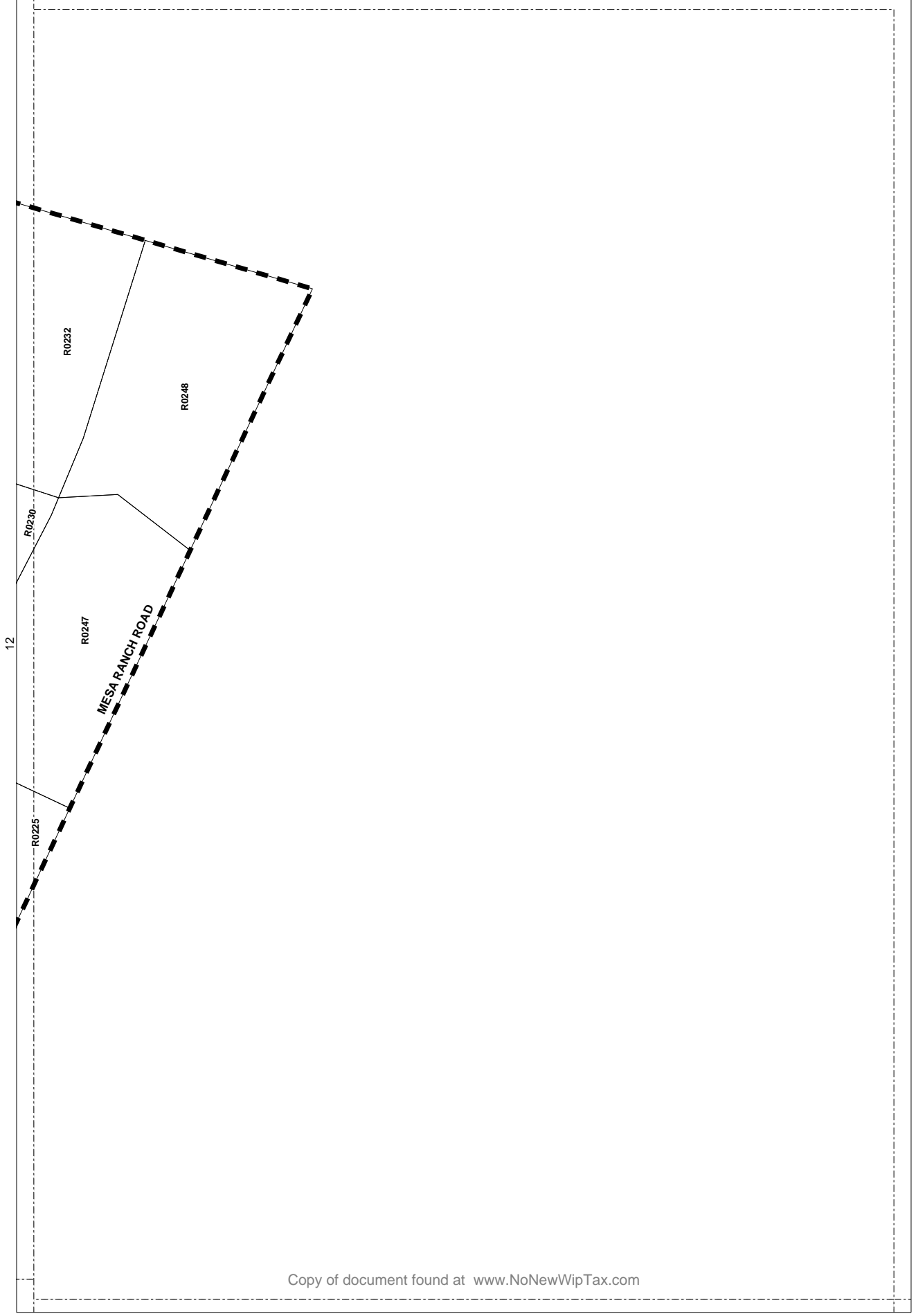



**ASSESSMENT
DIAGRAM**

NIPOMO MESA
SUPPLEMENTAL
ASSESSMENT DISTRICT
NO.1

NIPOMO COMMUNITY
SERVICES DISTRICT
STATE OF CALIFORNIA

Legend

-  ASSM BOUNDARY
-  ASSESSOR PARCEL
-  DIAGRAM SHEET

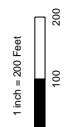

17

**SHEET:
16 OF 28**

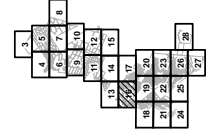

LOTS ON THIS SHEET ARE
BASED ON ASSESSORS
MAP COUNTY OF SAN LUIS
OBISPO COUNTY, 1991,
041, 042, 051, 061, 062, 063,
160, 161, 162, 164, 165, 171,
181, 202, 203, 204, 211, 241,
251, 252, 253, 254, 255,
364, 365, 390, 391, 392, 393,
400, 401, 402, 403, 404, 405,
406, 407, 408, 409, 410, 411,
412

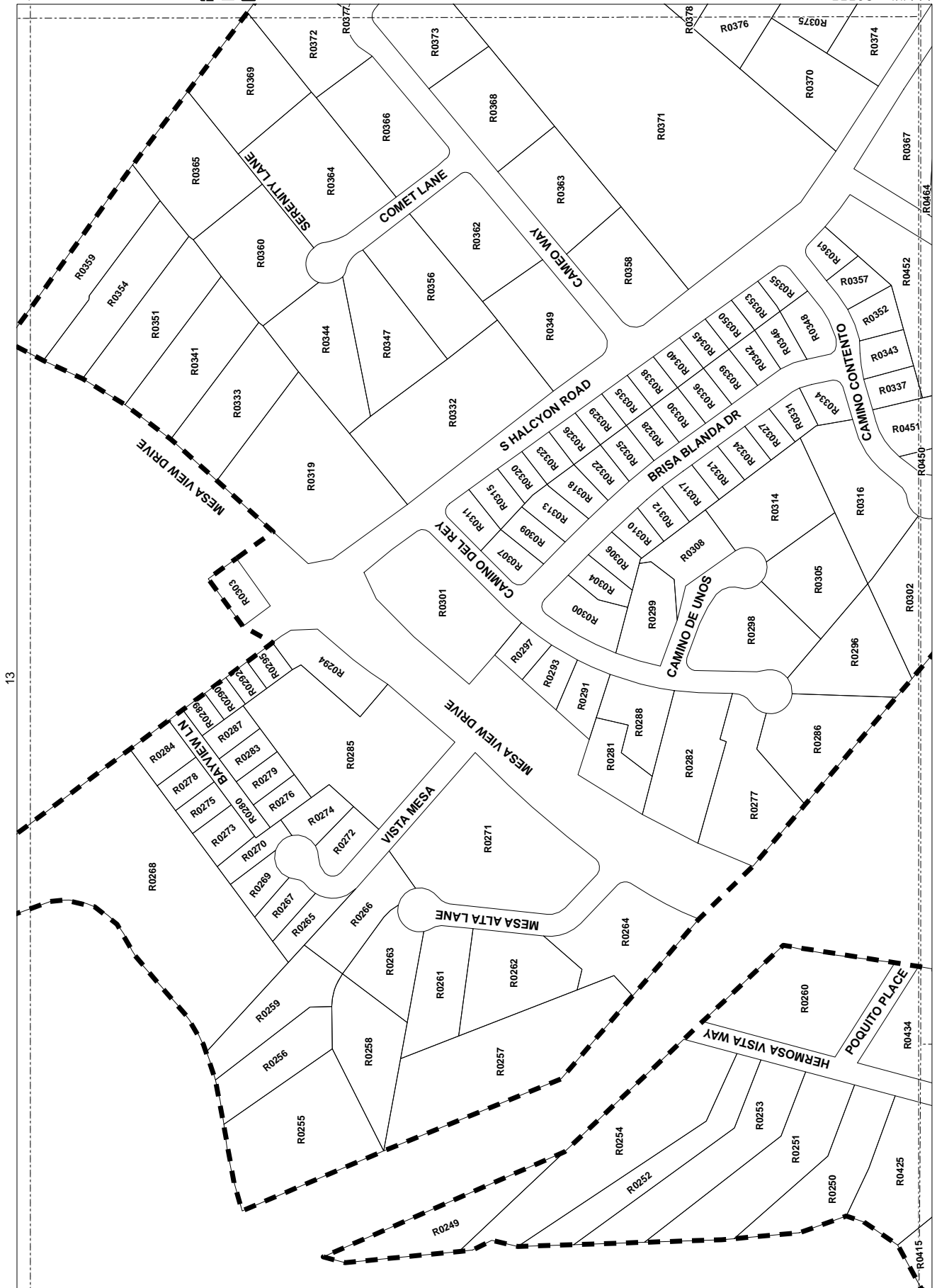





ASSESSMENT DIAGRAM

NIPOMO MESA
SUPPLEMENTAL
GENERAL PURPOSE
ASSESSMENT DISTRICT
NO.1

NIPOMO COMMUNITY
SERVICES DISTRICT
STATE OF CALIFORNIA

Legend

-  ASSESSOR PARCEL
-  ASSESSOR BOUNDARY
-  ASSESSOR PARCEL
-  DIAGRAM SHEET

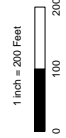

SHEET:
17 OF 28



LOTS ON THIS SHEET ARE
BASED ON ASSESSORS
MAP COUNTY OF SAN LUIS
OBISPO COUNTY OFFICE 1521,
0481 042 051 061 150 151,
160, 161, 162, 164, 165, 171,
181, 202, 203, 204, 211, 241,
242, 243, 244, 245, 246,
364, 365, 380, 381, 382, 383,
400, 401, 402, 403, 404, 405,
406, 407, 408, 409, 410, 411,
412.

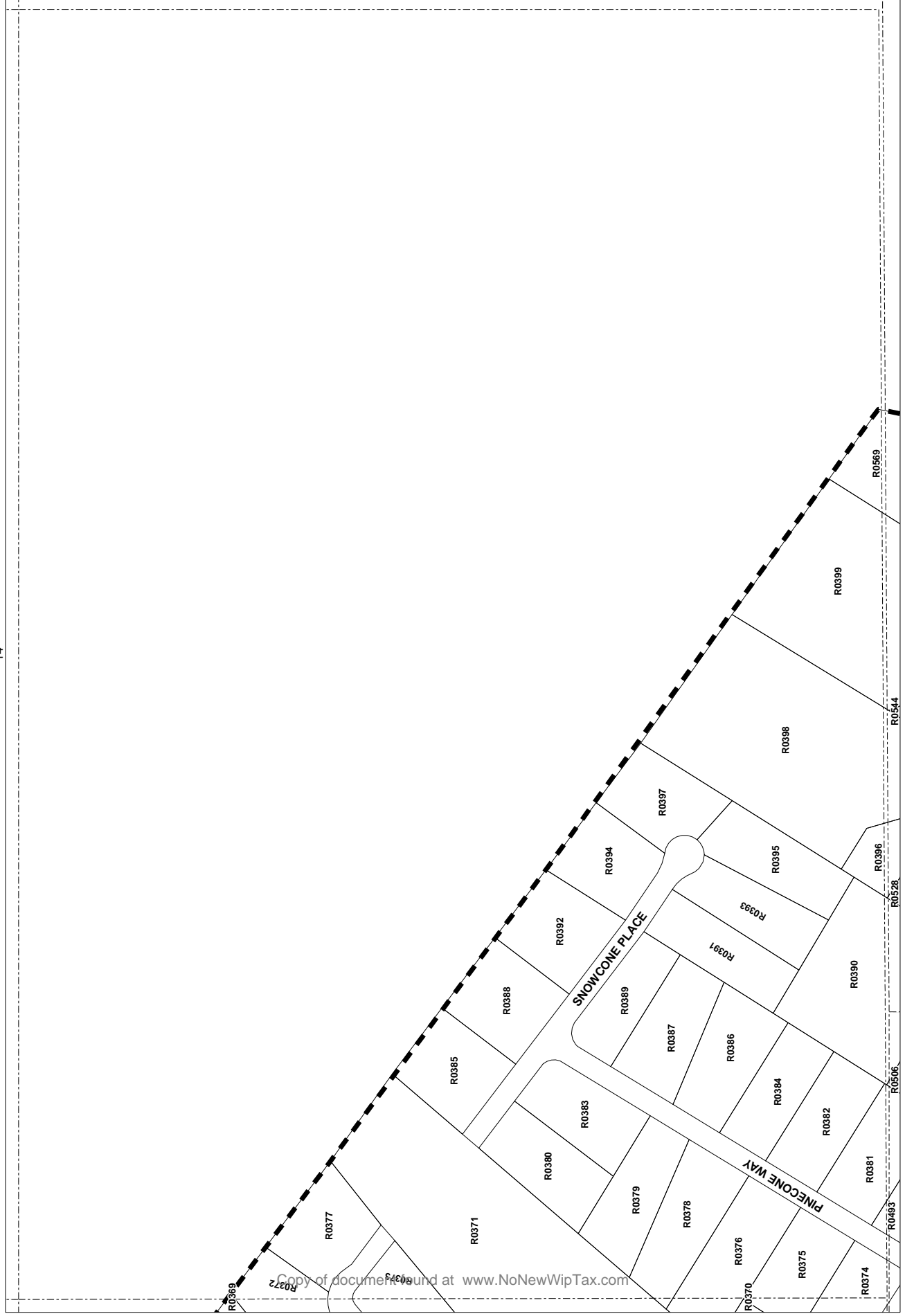





**ASSESSMENT
DIAGRAM**

NIPOMO MESA
SUPPLEMENTAL
SERVICES DISTRICT
ASSESSMENT DISTRICT
NO. 1

NIPOMO COMMUNITY
SERVICES DISTRICT
STATE OF CALIFORNIA

Legend

-  ASSESSOR BOUNDARY
-  ASSESSOR PARCEL
-  DIAGRAM SHEET



1 inch = 200 Feet

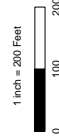

**SHEET:
18 OF 28**





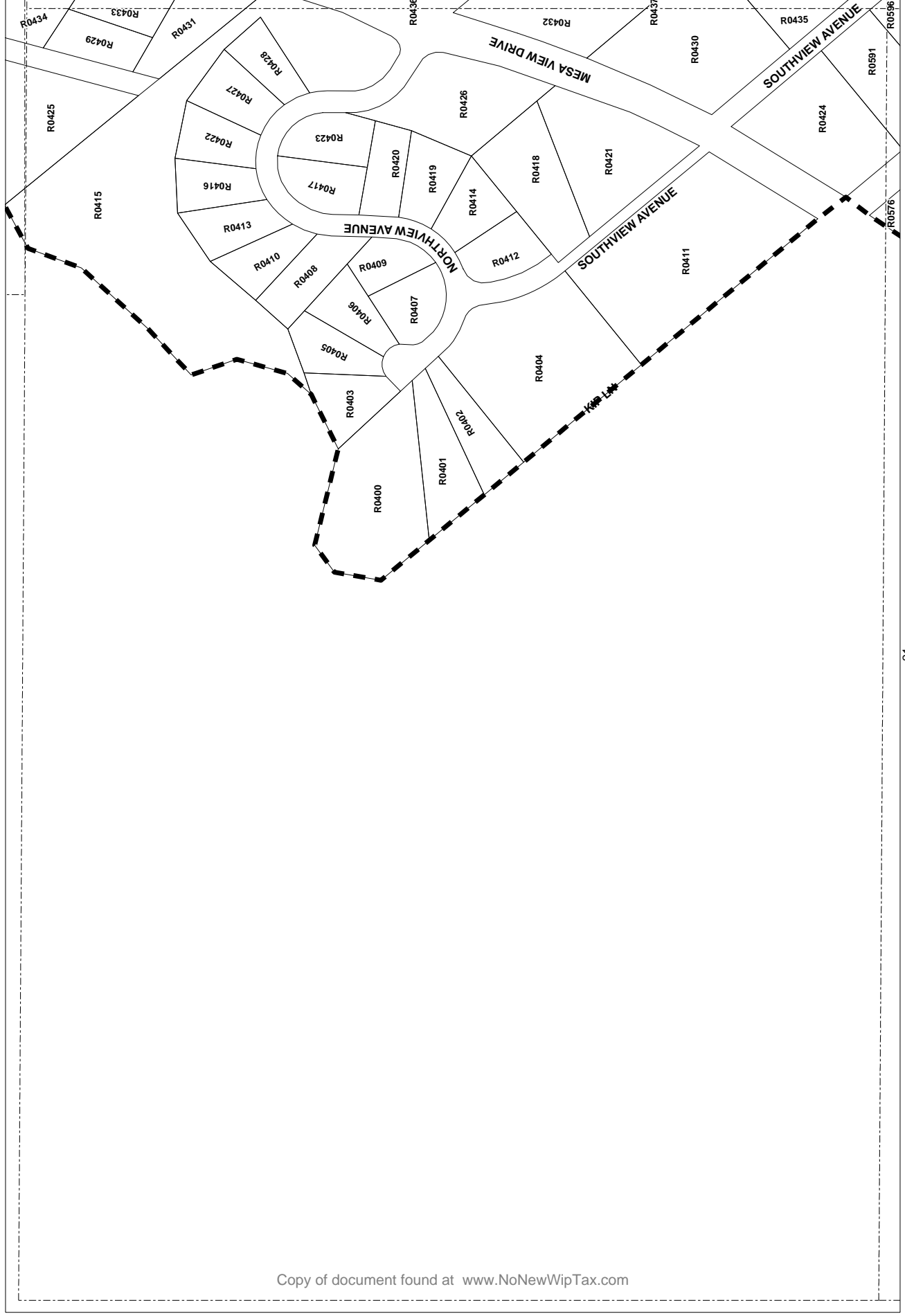

LOTS ON THIS SHEET ARE
BASED ON ASSESSORS
MAP COUNTY OF SAN LUIS
OBISPO COUNTY RECORDS
04811042 051 061 150 151
160 161 162 164 165 171
181 202 203 204 211 241
242 243 244 245 246 247
364 365 380 381 382 383
400 401 402 403 404 405
406 407 408 409 410 411
412



**ASSESSMENT
DIAGRAM**

NIPOMO MESA
SUPPLEMENTAL
ASSESSMENT DISTRICT
NO.1

NIPOMO COMMUNITY
SERVICES DISTRICT
STATE OF CALIFORNIA

- Legend**
-  ASSESSOR PARCEL
 -  ASSESSOR BOUNDARY
 -  ASSESSOR PARCEL
 -  DIAGRAM SHEET

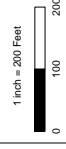

**SHEET:
20 OF 28**



LOTS ON THIS SHEET ARE
BASED ON ASSESSORS
MAP COUNTY OF SAN LUIS
OBISPO COUNTY, 1991
041, 042, 051, 061, 150, 151,
160, 161, 162, 164, 165, 171,
181, 202, 203, 204, 211, 241,
251, 252, 253, 254, 255,
364, 365, 380, 381, 382, 383,
400, 401, 402, 403, 404, 405,
406, 407, 408, 409, 410, 411,
412

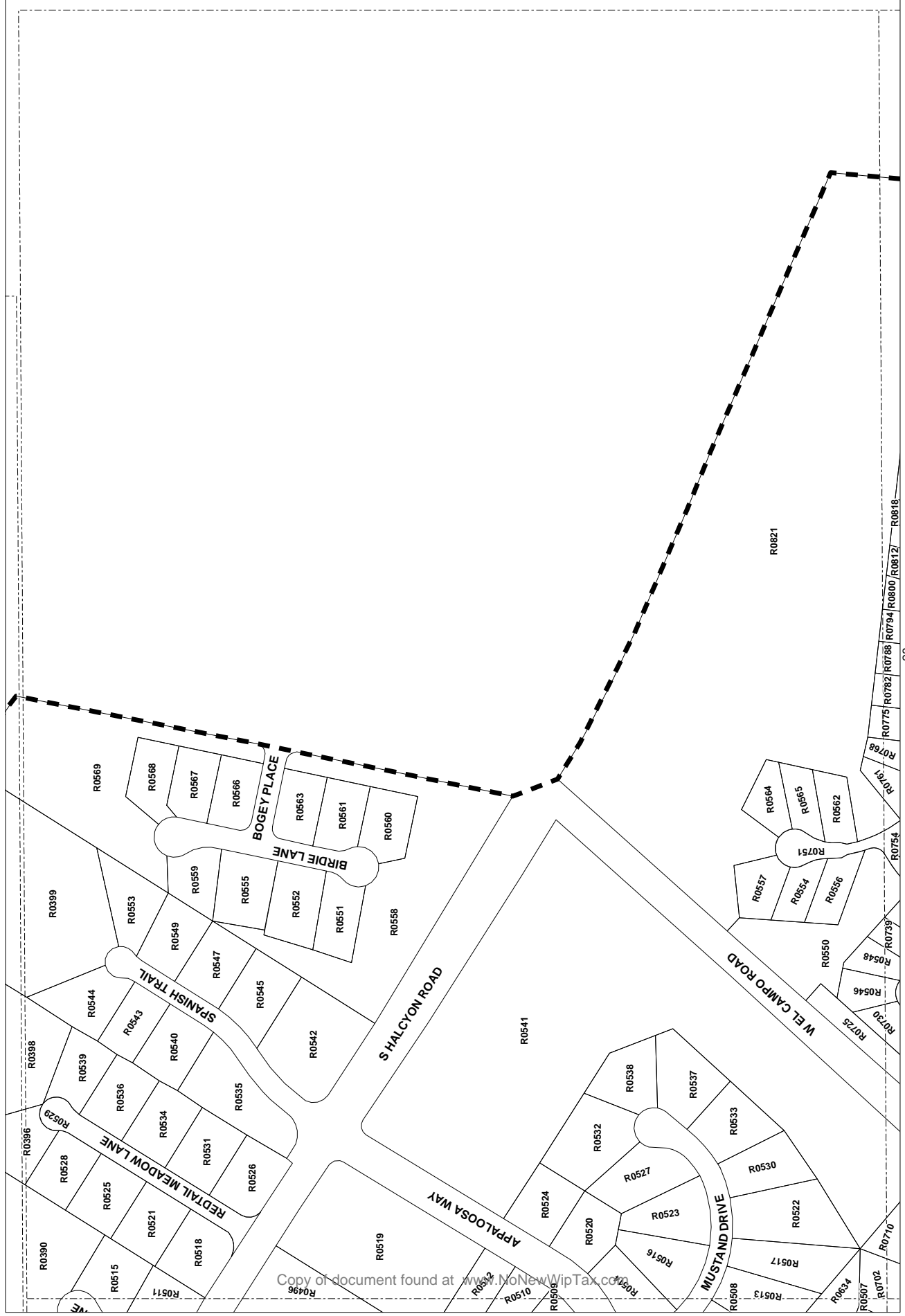



ASSESSMENT DIAGRAM

NIPOMO MESA
SUPPLEMENTAL
ASSESSMENT DISTRICT
NO.1

NIPOMO COMMUNITY
SERVICES DISTRICT
STATE OF CALIFORNIA

Legend

-  ASSESSOR PARCEL
-  ASSESSOR PARCEL
-  ASSESSOR PARCEL

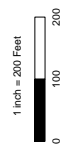

SHEET:
21 OF 28



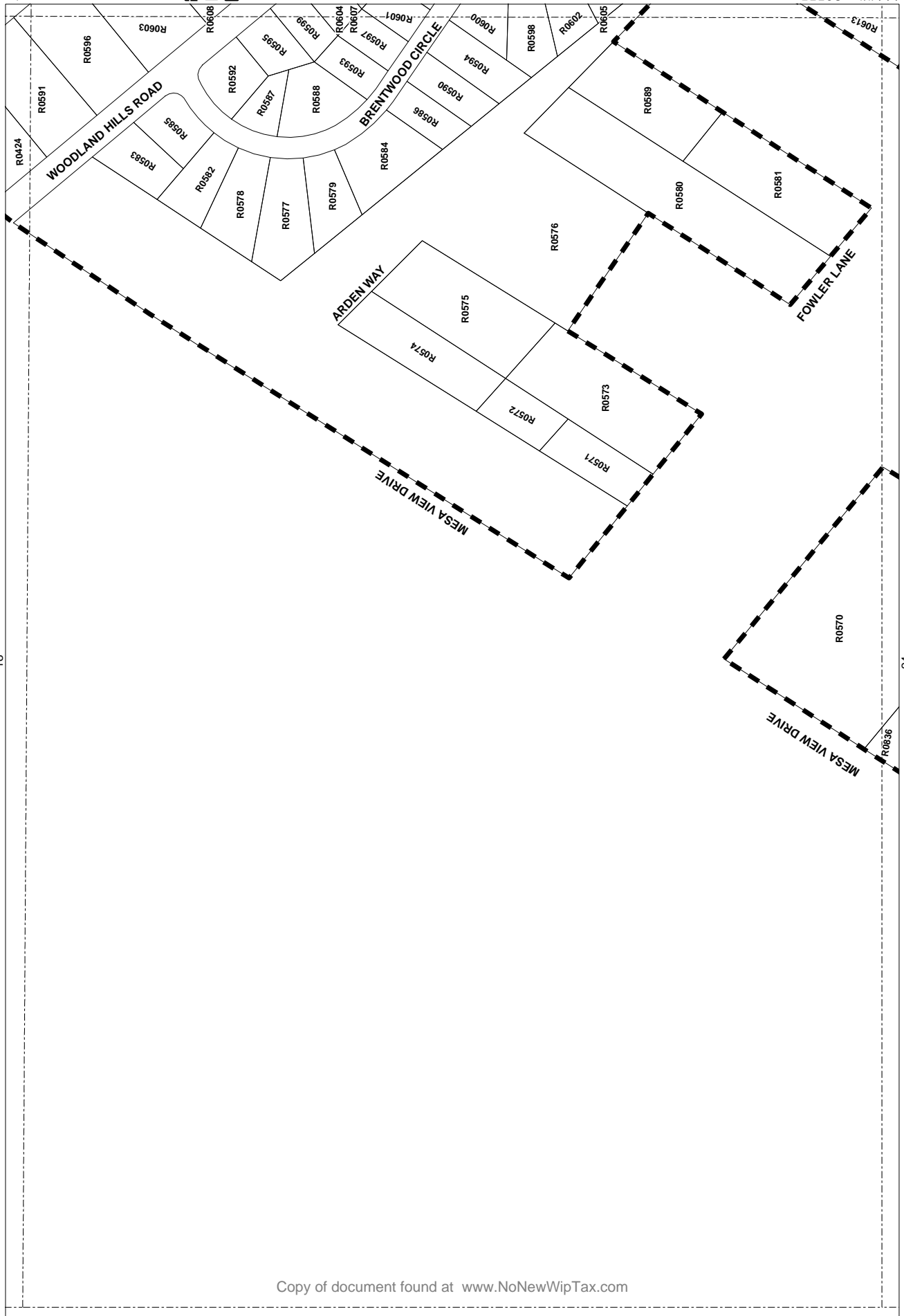

LOTS ON THIS SHEET ARE
BASED ON ASSESSORS
MAP COUNTY OF SAN LUIS
OBSOLETE MAPS: 001, 002, 003, 004, 005, 006, 007, 008, 009, 010, 011, 012, 013, 014, 015, 016, 017, 018, 019, 020, 021, 022, 023, 024, 025, 026, 027, 028, 029, 030, 031, 032, 033, 034, 035, 036, 037, 038, 039, 040, 041, 042, 043, 044, 045, 046, 047, 048, 049, 050, 051, 052, 053, 054, 055, 056, 057, 058, 059, 060, 061, 062, 063, 064, 065, 066, 067, 068, 069, 070, 071, 072, 073, 074, 075, 076, 077, 078, 079, 080, 081, 082, 083, 084, 085, 086, 087, 088, 089, 090, 091, 092, 093, 094, 095, 096, 097, 098, 099, 100, 101, 102, 103, 104, 105, 106, 107, 108, 109, 110, 111, 112, 113, 114, 115, 116, 117, 118, 119, 120, 121, 122, 123, 124, 125, 126, 127, 128, 129, 130, 131, 132, 133, 134, 135, 136, 137, 138, 139, 140, 141, 142, 143, 144, 145, 146, 147, 148, 149, 150, 151, 152, 153, 154, 155, 156, 157, 158, 159, 160, 161, 162, 163, 164, 165, 166, 167, 168, 169, 170, 171, 172, 173, 174, 175, 176, 177, 178, 179, 180, 181, 182, 183, 184, 185, 186, 187, 188, 189, 190, 191, 192, 193, 194, 195, 196, 197, 198, 199, 200, 201, 202, 203, 204, 205, 206, 207, 208, 209, 210, 211, 212, 213, 214, 215, 216, 217, 218, 219, 220, 221, 222, 223, 224, 225, 226, 227, 228, 229, 230, 231, 232, 233, 234, 235, 236, 237, 238, 239, 240, 241, 242, 243, 244, 245, 246, 247, 248, 249, 250, 251, 252, 253, 254, 255, 256, 257, 258, 259, 260, 261, 262, 263, 264, 265, 266, 267, 268, 269, 270, 271, 272, 273, 274, 275, 276, 277, 278, 279, 280, 281, 282, 283, 284, 285, 286, 287, 288, 289, 290, 291, 292, 293, 294, 295, 296, 297, 298, 299, 300, 301, 302, 303, 304, 305, 306, 307, 308, 309, 310, 311, 312, 313, 314, 315, 316, 317, 318, 319, 320, 321, 322, 323, 324, 325, 326, 327, 328, 329, 330, 331, 332, 333, 334, 335, 336, 337, 338, 339, 340, 341, 342, 343, 344, 345, 346, 347, 348, 349, 350, 351, 352, 353, 354, 355, 356, 357, 358, 359, 360, 361, 362, 363, 364, 365, 366, 367, 368, 369, 370, 371, 372, 373, 374, 375, 376, 377, 378, 379, 380, 381, 382, 383, 384, 385, 386, 387, 388, 389, 390, 391, 392, 393, 394, 395, 396, 397, 398, 399, 400, 401, 402, 403, 404, 405, 406, 407, 408, 409, 410, 411, 412.



**ASSESSMENT
DIAGRAM**

NIPOMO MESA
SUPPLEMENTAL
SERVICES DISTRICT
ASSESSMENT DISTRICT
NO.1

NIPOMO COMMUNITY
SERVICES DISTRICT
STATE OF CALIFORNIA

- Legend**
-  ASSM BOUNDARY
 -  ASSESSOR PARCEL
 -  DIAGRAM SHEET

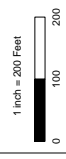

25

**SHEET:
24 OF 28**



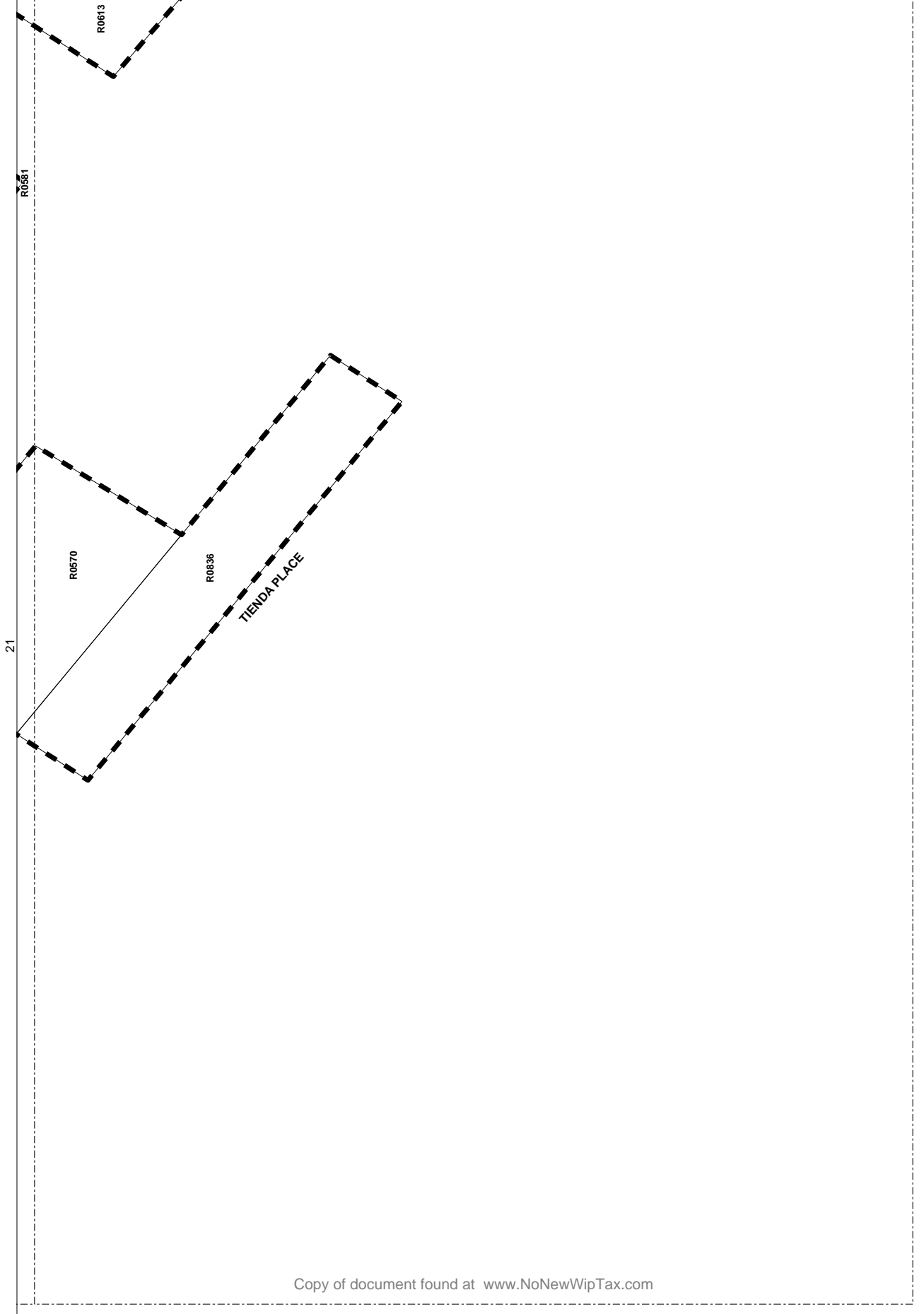

LOTS ON THIS SHEET ARE
BASED ON ASSESSORS
MAP COUNTY OF SAN LUIS
OBSOLETE MAPS: 181, 182,
041, 042, 051, 061, 150, 151,
160, 161, 162, 164, 165, 171,
181, 202, 203, 204, 211, 241,
242, 243, 244, 245, 246,
364, 365, 380, 381, 382, 383,
400, 401, 402, 403, 404, 405,
406, 407, 408, 409, 410, 411,
412.



**ASSESSMENT
DIAGRAM**

NIPOMO MESA
SUPPLEMENTAL
SERVICES DISTRICT
ASSESSMENT DISTRICT
NO.1

NIPOMO COMMUNITY
SERVICES DISTRICT
STATE OF CALIFORNIA

- Legend**
-  ASSESSOR PARCEL
 -  ASSESSOR BOUNDARY
 -  DIAGRAM SHEET

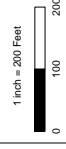

**SHEET:
28 OF 28**



LOTS ON THIS SHEET ARE
BASED ON ASSESSORS
MAP COUNTY OF SAN LUIS
OBISPO COUNTY, 1992-1993
0491, 042, 051, 061, 150, 151,
160, 161, 162, 164, 165, 171,
181, 202, 203, 204, 211, 241,
242, 243, 244, 245, 246,
364, 365, 380, 381, 382, 383,
400, 401, 402, 403, 404, 405,
406, 407, 408, 409, 410, 411,
412.

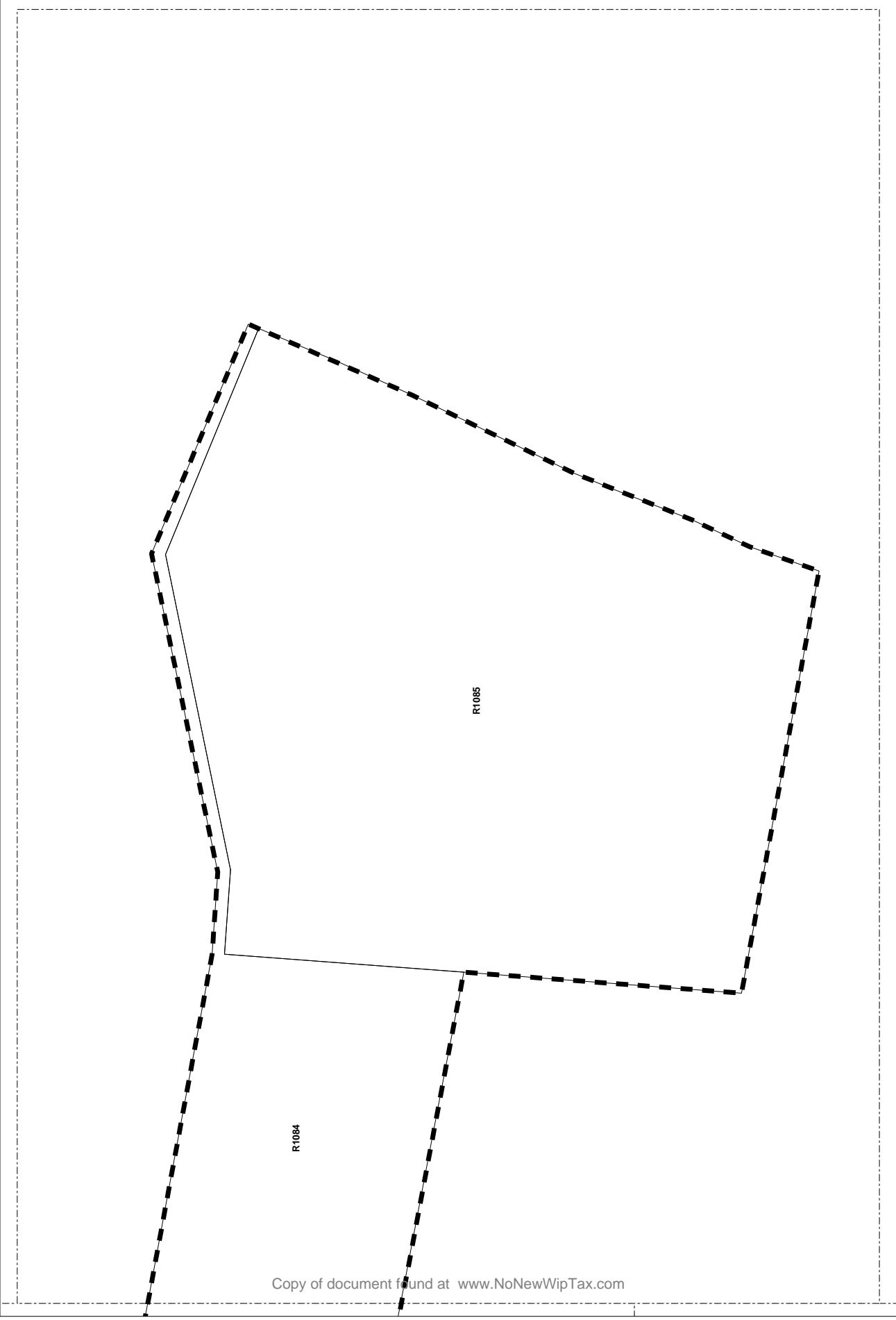

Nipomo Mesa Supplemental Water Project Assessment District No. 1

Nipomo Community Services District
State of California



Part V
Assessment Diagram

For
Woodlands Mutual Water Company

February 2012 Draft







**ASSESSMENT
DIAGRAM**

NIPOMO MESA
SUPPLEMENTAL
SERVICES DISTRICT
ASSESSMENT DISTRICT
NO.1

NIPOMO COMMUNITY
SERVICES DISTRICT
STATE OF CALIFORNIA

Legend

-  ASSM BOUNDARY
-  ASSESSOR PARCEL
-  DIAGRAM SHEET



1 inch = 800 Feet

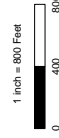

**SHEET:
1 OF 12**

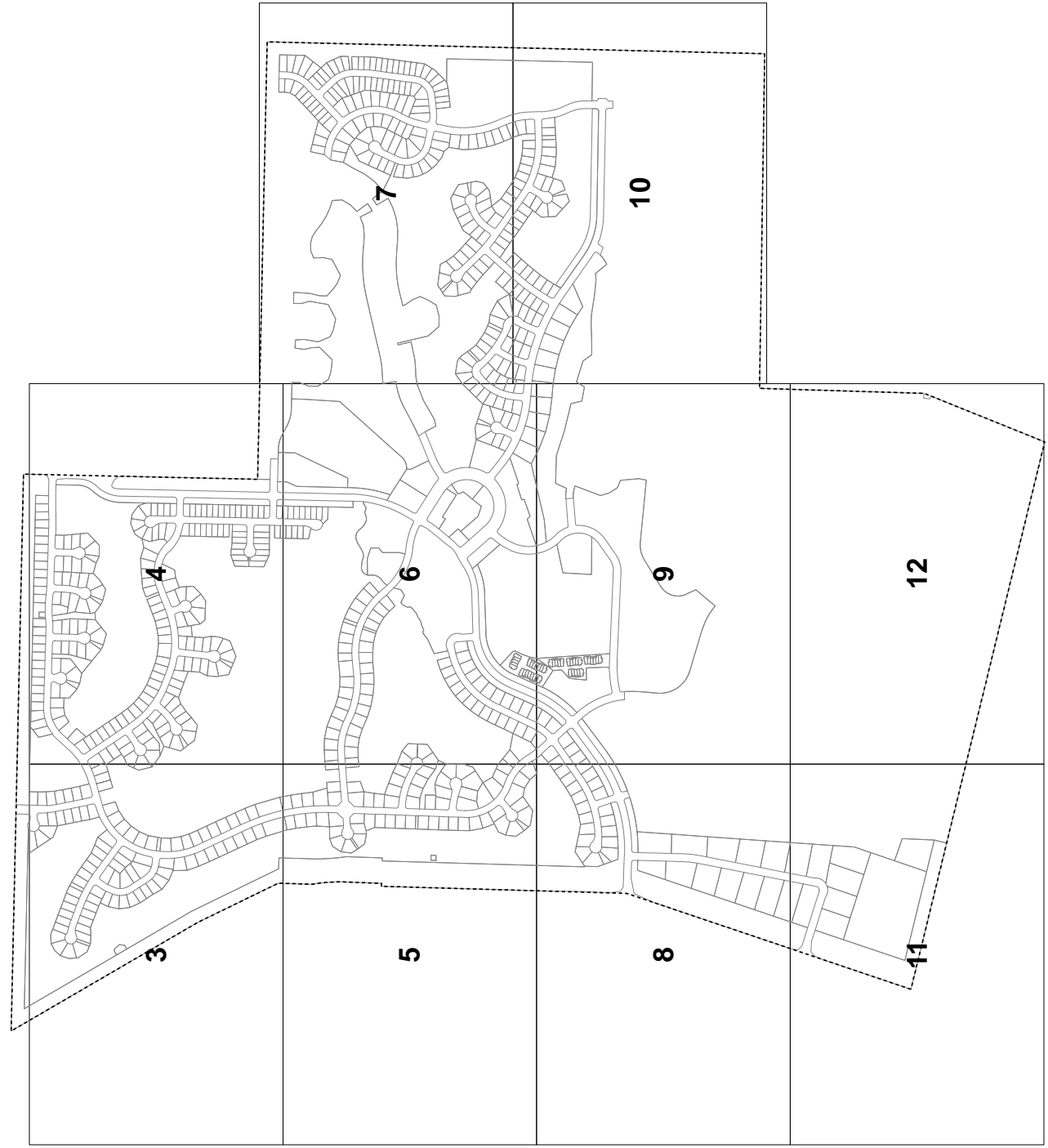

LOTS ON THIS SHEET ARE
BASED ON ASSESSORS
MAP COUNTY OF SAN LUIS
OBISPO COUNTY TRACTS:
506 PG 503, 504, 505, 506,
507, 508, 509, 600, 601, 602,
603, 604, 605, 606, 607, 608,
609, 610, 611, 701, 702, 703,
704, 705, 706.

LOTS SHOWN ON THIS
MAP ARE BASED ON THE
WOODLAND TRACTS: 2341-1
BK 26 PG 14-17, 2341-2 BK 27
PG 88-93, 2341-3 BK 30 PG
10-15, 2341-4 BK 31 PG 16-20,
2341-5 BK 31 PG 35-42, 2341-6
BK 31 PG 15-16, LOS
BERROS TRACT BK A
PG 108.

ASSESSMENT NUMBER INDEX



















<u>SHEET NUMBER:</u>	<u>ASSESSMENT NUMBER:</u>
SHEET 3	0001-0096
SHEET 4	0097-0309
SHEET 5	0310-0377
SHEET 6	0378-0513
SHEET 7	0514-0684
SHEET 8	0685-0720
SHEET 9	0721-0763
SHEET 10	0764-0821
SHEET 11	0822-0831
SHEET 12	0832

**ASSESSMENT
DIAGRAM**

NIPOMO MESA
SUPPLEMENTAL
MAP TO THE
ASSESSMENT DISTRICT
NO. 1

NIPOMO COMMUNITY
SERVICES DISTRICT
STATE OF CALIFORNIA

Legend

-  ASSESSOR PARCEL
-  ASSESSOR PARCEL
-  ASSESSOR PARCEL
-  ASSESSOR PARCEL
-  ASSESSOR PARCEL
-  ASSESSOR PARCEL
-  ASSESSOR PARCEL
-  ASSESSOR PARCEL
-  ASSESSOR PARCEL
-  ASSESSOR PARCEL
-  ASSESSOR PARCEL
-  ASSESSOR PARCEL
-  ASSESSOR PARCEL
-  ASSESSOR PARCEL
-  ASSESSOR PARCEL
-  ASSESSOR PARCEL
-  ASSESSOR PARCEL
-  ASSESSOR PARCEL
-  ASSESSOR PARCEL
-  ASSESSOR PARCEL
-  ASSESSOR PARCEL
-  ASSESSOR PARCEL
-  ASSESSOR PARCEL
-  ASSESSOR PARCEL
-  ASSESSOR PARCEL
-  ASSESSOR PARCEL
-  ASSESSOR PARCEL
-  ASSESSOR PARCEL
-  ASSESSOR PARCEL
-  ASSESSOR PARCEL
-  ASSESSOR PARCEL
-  ASSESSOR PARCEL
-  ASSESSOR PARCEL
-  ASSESSOR PARCEL
-  ASSESSOR PARCEL
-  ASSESSOR PARCEL
-  ASSESSOR PARCEL
-  ASSESSOR PARCEL
-  ASSESSOR PARCEL
-  ASSESSOR PARCEL
-  ASSESSOR PARCEL
-  ASSESSOR PARCEL
-  ASSESSOR PARCEL
-  ASSESSOR PARCEL
-  ASSESSOR PARCEL
-  ASSESSOR PARCEL
-  ASSESSOR PARCEL
-  ASSESSOR PARCEL
-  ASSESSOR PARCEL
-  ASSESSOR PARCEL
-  ASSESSOR PARCEL
-  ASSESSOR PARCEL
-  ASSESSOR PARCEL
-  ASSESSOR PARCEL
-  ASSESSOR PARCEL
-  ASSESSOR PARCEL
-  ASSESSOR PARCEL
-  ASSESSOR PARCEL
-  ASSESSOR PARCEL
-  ASSESSOR PARCEL
-  ASSESSOR PARCEL
-  ASSESSOR PARCEL



1 Inch = 200 Feet
0 100 200

**SHEET:
3 OF 12**



LOTS ON THIS SHEET ARE
BASED ON ASSESSOR'S
MAP COUNTY OF SAN LUIS
OBISPO COUNTY
507 508 509 500 601 602
603 604 605 606 607 608
609 610 611 701 702 703
704 705 706

LOTS SHOWN ON THIS
SHEET ARE BASED ON THE
WOODLAND TRACTS: 2341-1
BK 28 PG 14-41, 2341-2 BK 27
PG 89-93, 2341-3 BK 30 PG
85-88, 2341-4 BK 31 PG
2341-5 BK 31 PG 35-42, 2759
BK 31 PG 15-16, LOS
BERNOS TRACT BKA
PG 108

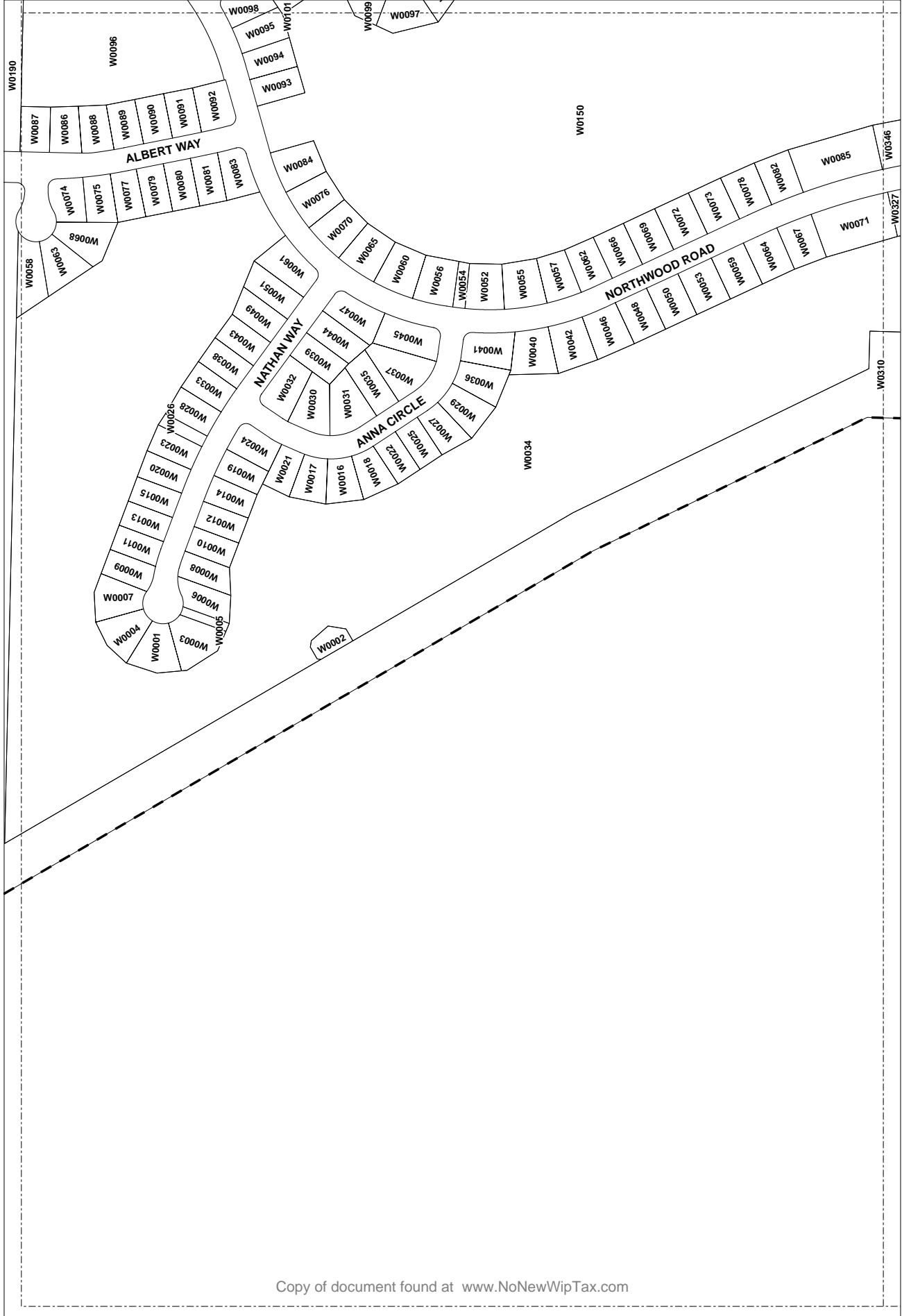

**ASSESSMENT
DIAGRAM**

NIPOMO MESA
SUPPLEMENTAL
REVENUE DISTRICT
ASSESSMENT DISTRICT
NO.1

NIPOMO COMMUNITY
SERVICES DISTRICT
STATE OF CALIFORNIA

Legend

- ASSESSOR PARCEL
- ASSESSOR BOUNDARY
- ASSESSOR PARCEL
- DIAGRAM SHEET



1 inch = 200 Feet
0 100 200

**SHEET:
4 OF 12**

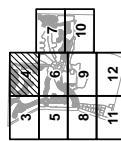

LOTS ON THIS SHEET ARE
BASED ON ASSESSOR'S
MAP COUNTY OF SAN LUIS
OBISPO, 2015, 2016, 2017,
2018, 2019, 2020, 2021,
2022, 2023, 2024, 2025,
2026, 2027, 2028, 2029,
2030, 2031, 2032, 2033,
2034, 2035, 2036, 2037,
2038, 2039, 2040, 2041,
2042, 2043, 2044, 2045,
2046, 2047, 2048, 2049,
2050, 2051, 2052, 2053,
2054, 2055, 2056, 2057,
2058, 2059, 2060, 2061, 2062,
2063, 2064, 2065, 2066, 2067, 2068,
2069, 2070, 2071, 2072, 2073,
2074, 2075, 2076.

LOTS SHOWN ON THIS
DIAGRAM ARE BASED ON THE
WOODLAND TRACTS: 2341-1
BK 26 PG 14-41, 2341-2 BK 27
PG 89-93, 2341-3 BK 30 PG
89-93, 2341-4 BK 31 PG 89-93,
2341-5 BK 31 PG 89-93, 2341-6
BK 31 PG 15-16, LOS
BERROS TRACT BKA
PG 108.

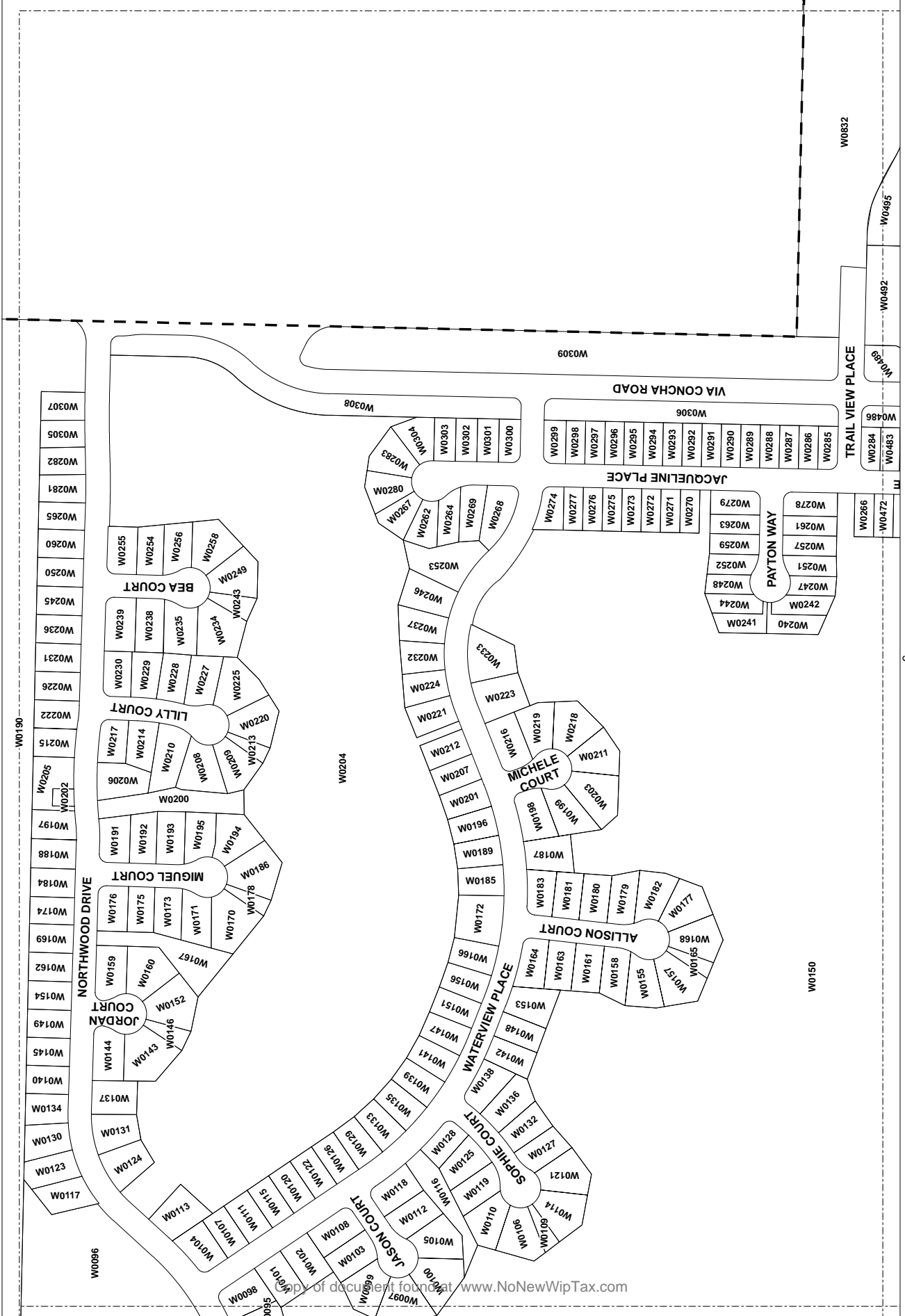

W0190

W0086

W0204

W0150

W0832

W0495

W0492

W0486

W0483

W0472

W0286

6

**ASSESSMENT
DIAGRAM**

NIPOMO MESA
SUPPLEMENTAL
ASSESSMENT DISTRICT
NO. 1

NIPOMO COMMUNITY
SERVICES DISTRICT
STATE OF CALIFORNIA

Legend

-  ASSESSOR PARCEL
-  ASSESSOR BOUNDARY
-  DIAGRAM SHEET



1 Inch = 200 Feet
0 100 200

**SHEET:
6 OF 12**



LOTS SHOWN ON THIS MAP ARE BASED ON THE MAP COUNTY OF SAN LUIS OBISPO, CALIFORNIA. THE MAP COUNTY OF SAN LUIS OBISPO, CALIFORNIA, 507.508.509.600.601.602.603.604.605.606.607.608.609.610.611.612.613.614.615.616.617.618.619.620.621.622.623.624.625.626.627.628.629.630.631.632.633.634.635.636.637.638.639.640.641.642.643.644.645.646.647.648.649.650.651.652.653.654.655.656.657.658.659.660.661.662.663.664.665.666.667.668.669.670.671.672.673.674.675.676.677.678.679.680.681.682.683.684.685.686.687.688.689.690.691.692.693.694.695.696.697.698.699.700.701.702.703.704.705.706.707.708.709.710.711.712.713.714.715.716.717.718.719.720.721.722.723.724.725.726.727.728.729.730.731.732.733.734.735.736.737.738.739.740.741.742.743.744.745.746.747.748.749.750.751.752.753.754.755.756.757.758.759.760.761.762.763.764.765.766.767.768.769.770.771.772.773.774.775.776.777.778.779.780.781.782.783.784.785.786.787.788.789.790.791.792.793.794.795.796.797.798.799.800.801.802.803.804.805.806.807.808.809.810.811.812.813.814.815.816.817.818.819.820.821.822.823.824.825.826.827.828.829.830.831.832.833.834.835.836.837.838.839.840.841.842.843.844.845.846.847.848.849.850.851.852.853.854.855.856.857.858.859.860.861.862.863.864.865.866.867.868.869.870.871.872.873.874.875.876.877.878.879.880.881.882.883.884.885.886.887.888.889.890.891.892.893.894.895.896.897.898.899.900.901.902.903.904.905.906.907.908.909.910.911.912.913.914.915.916.917.918.919.920.921.922.923.924.925.926.927.928.929.930.931.932.933.934.935.936.937.938.939.940.941.942.943.944.945.946.947.948.949.950.951.952.953.954.955.956.957.958.959.960.961.962.963.964.965.966.967.968.969.970.971.972.973.974.975.976.977.978.979.980.981.982.983.984.985.986.987.988.989.990.991.992.993.994.995.996.997.998.999.1000.

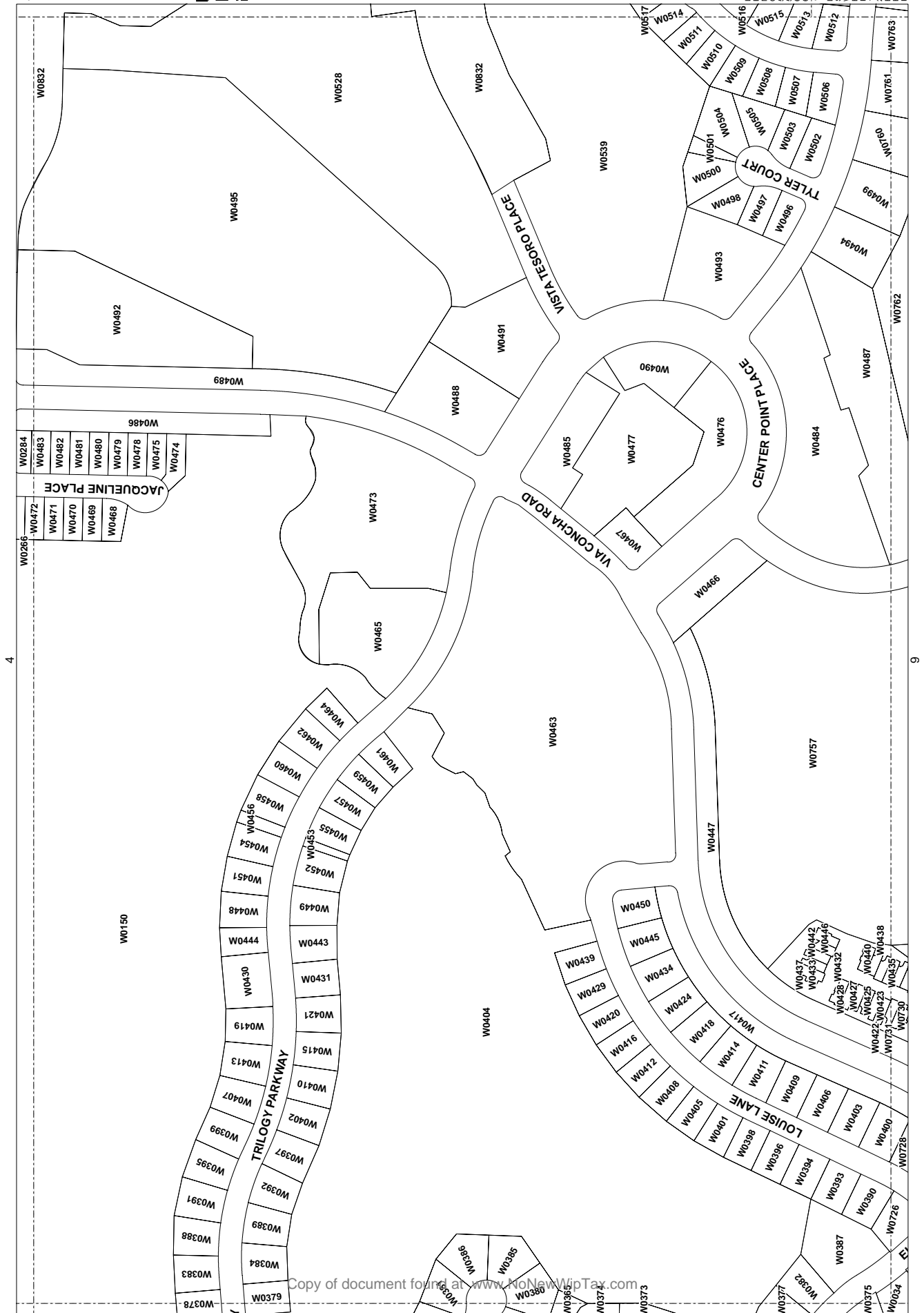

**ASSESSMENT
DIAGRAM**

NIPOMO MESA
SUPPLEMENTAL
ASSESSMENT DISTRICT
NO.1

NIPOMO COMMUNITY
SERVICES DISTRICT
STATE OF CALIFORNIA

Legend

-  ASSESSOR PARCEL
-  ASSESSOR BOUNDARY
-  DIAGRAM SHEET



1 Inch = 200 Feet
0 100 200

**SHEET:
10 OF 12**



LOTS ON THIS SHEET ARE
BASED ON ASSESSOR'S
MAP COUNTY OF SAN LUIS
OBISPO COUNTY
507 508 509 500 601 602
603 604 605 606 607 608
609 610 611 701 702 703
704 705 706



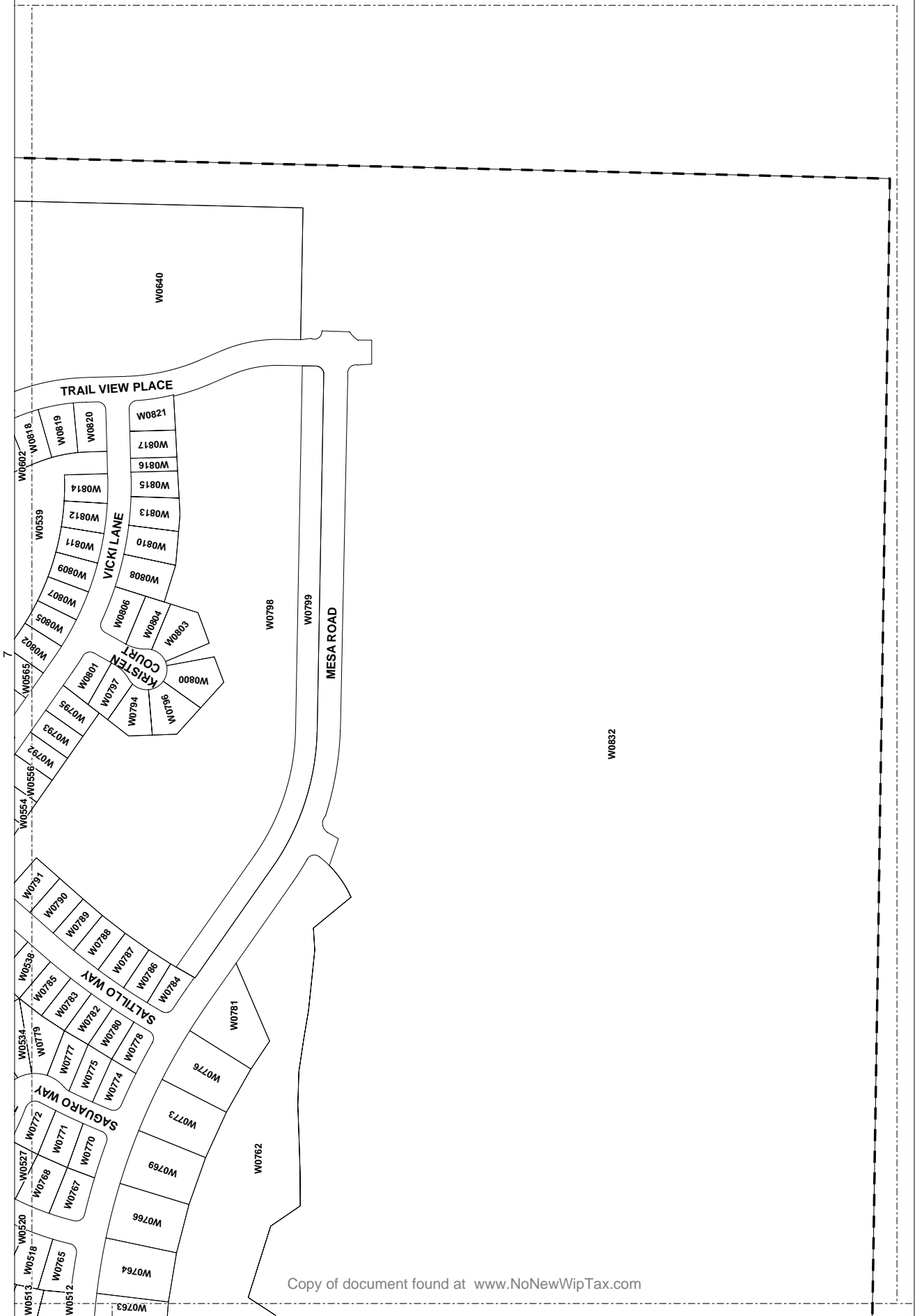

LOTS SHOWN ON THIS
SHEET ARE NOT THE
WOODLAND TRACTS: 2341-1
BK 26 PG 14-41, 2341-2 BK 27
PG 89-93, 2341-3 BK 30 PG
14-16, 2341-4 BK 31 PG
2341-4 BK 31 PG 38-42, 2759
BK 31 PG 15-16, LOS
BERNOS TRACT BKA
PG 108



**ASSESSMENT
DIAGRAM**

NIPOMO MESA
SUPPLEMENTAL
EVALUATION DISTRICT
ASSESSMENT DISTRICT
NO.1

NIPOMO COMMUNITY
SERVICES DISTRICT
STATE OF CALIFORNIA

- Legend**
-  ASSESSOR PARCEL
 -  ASSESSOR PARCEL
 -  ASSESSOR PARCEL
 -  DIAGRAM SHEET

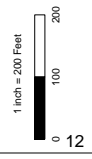

**SHEET:
11 OF 12**



LOTS ON THIS SHEET ARE
BASED ON ASSESSOR'S
MAP COUNTY OF SAN LUIS
OBISPO COUNTY, CALIFORNIA
507-508, 509, 504, 505, 506,
507, 508, 509, 500, 601, 602,
603, 604, 605, 606, 607, 608,
609, 610, 701, 702, 703,
704, 705, 706.

LOTS SHOWN ON THIS
SHEET ARE NOT THE
WOODLAND TRACTS: 2341-1
BK 26 PG 14-41, 2341-2 BK 27
PG 89-93, 2341-3 BK 30 PG
105-109, 2341-4 BK 31 PG
2341-5 BK 31 PG 35-42, 2758
BK 31 PG 15-16, LOS
BERNOS TRACT BKA

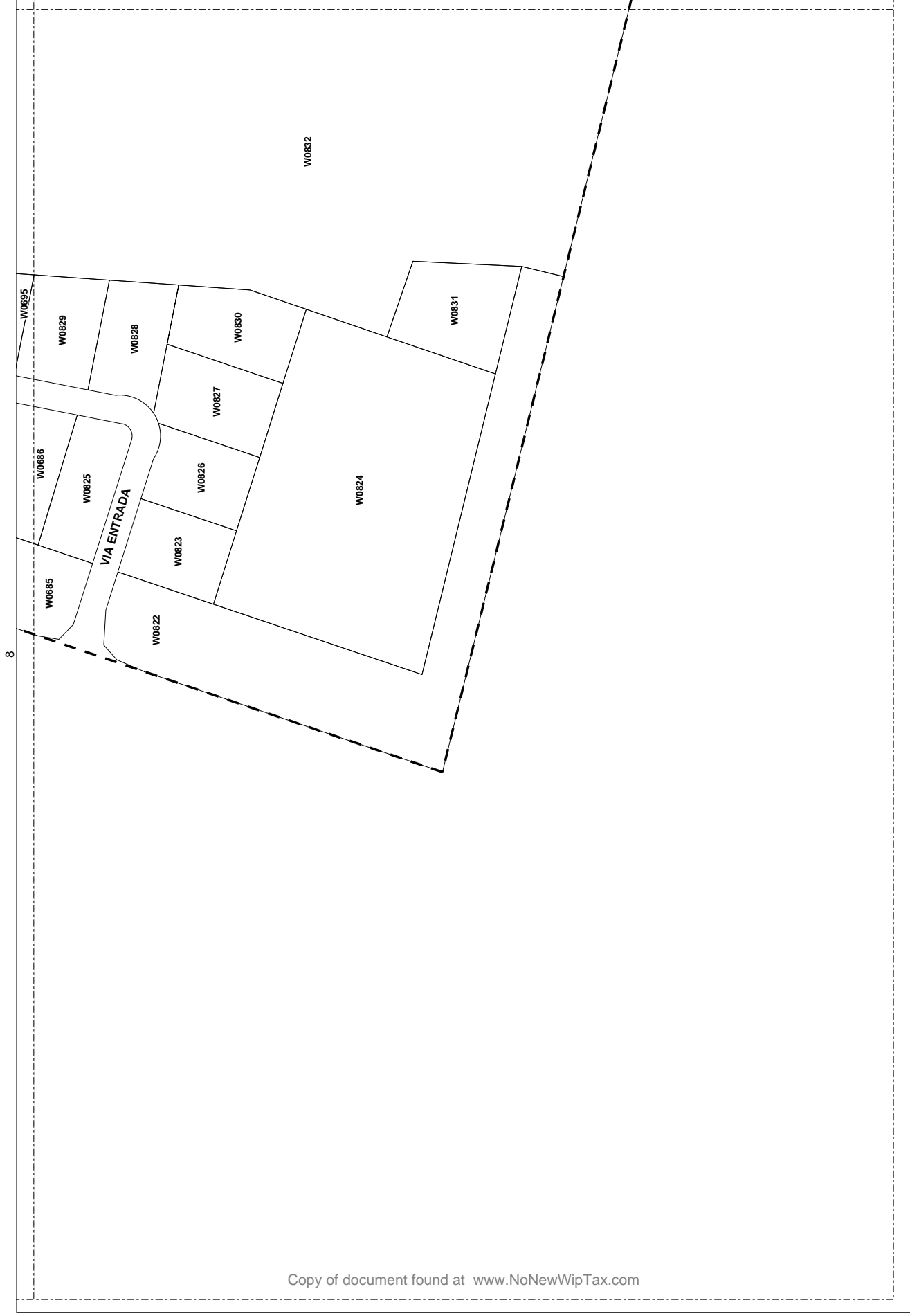

ASSESSMENT DIAGRAM

NIPOMO MESA
SUPPLEMENTAL
ASSESSMENT DISTRICT
NO.1

NIPOMO COMMUNITY
SERVICES DISTRICT
STATE OF CALIFORNIA

Legend

-  ASSESSOR PARCEL
-  ASSESSOR BOUNDARY
-  DIAGRAM SHEET



1 Inch = 200 Feet
0 100 200

**SHEET:
12 OF 12**



LOTS ON THIS SHEET ARE
BASED ON ASSESSOR'S
MAP COUNTY OF SAN LUIS
OBIEN TRACTS: 2341-1
PG 28 PG 14-41, 2341-2 BK 27
PG 89-93, 2341-3 BK 20 PG
507, 508, 509, 504, 505, 506,
507, 508, 509, 500, 601, 602,
603, 604, 605, 606, 607, 608,
609, 610, 701, 702, 703,
704, 705, 706.

LOTS SHOWN ON THIS
SHEET ARE NOT THE
WOODLAND TRACTS: 2341-1
BK 28 PG 14-41, 2341-2 BK 27
PG 89-93, 2341-3 BK 20 PG
507, 508, 509, 504, 505, 506,
2341-4 BK 31 PG 35-42, 2759,
BK 31 PG 15-16, LOS
BERNOS TRACT BKA
PG 108.

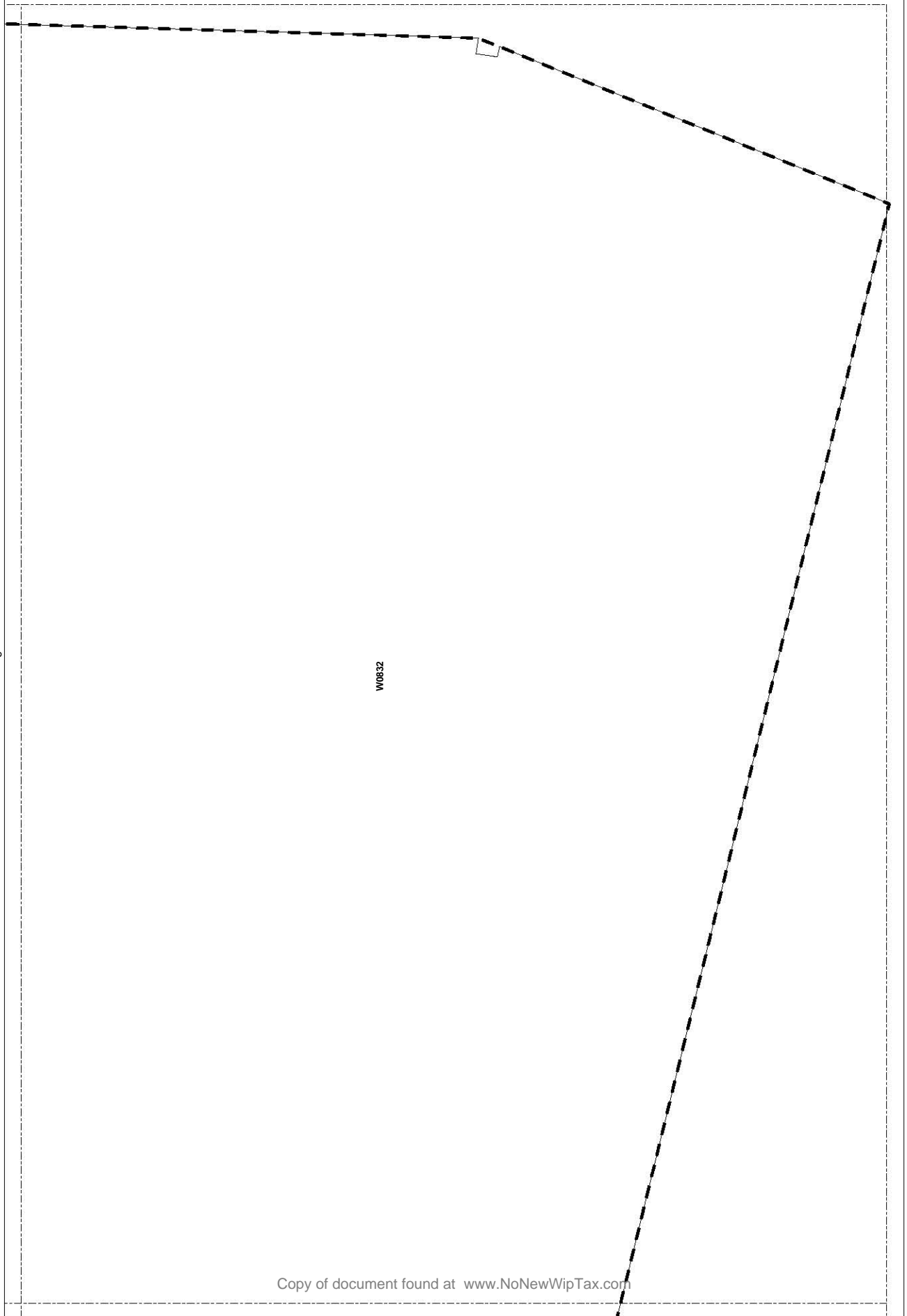

W00332

Nipomo Mesa Supplemental Water Project Assessment District No. 1

Nipomo Community Services District
State of California



Part V
Assessment Diagram

For
Golden State Water Company

February 2012 Draft







ASSESSMENT DIAGRAM

NIPOMO MESA
SUPPLEMENTAL
ASSESSMENT DISTRICT
NO.1

NIPOMO COMMUNITY
SERVICES DISTRICT
STATE OF CALIFORNIA

Legend

-  ASSESSOR PARCEL
-  ASSESSOR BOUNDARY
-  DIAGRAM SHEET



1 inch = 1,200 Feet

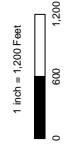

SHEET:
1 OF 21



LOTS ON THIS SHEET ARE
BASED ON ASSESSORS'
MAP COUNTY OF SAN LUIS
OBISPO, CA. BK 080 PG 271,
096, 097, 098, 099, 100, 101, 102, 103,
104, 105, 106, 107, 111, 122,
123, 124, 125, 126, 127, 128,
162, 172, 173, 174, 175, 181,
182, 183, 205, 206, 421, 422,
423, 424, 431, 432, 433, 434,
435, 436, 437, 438, 439, 440,
446, 447, 448, 451, 452, 453,
454, 455, 456, 457, 472, 473,
482, 491, 501, 510, 511, 521,
541, 542, 546, 567, 568, 569.

ASSESSMENT NUMBER INDEX



<u>SHEET NUMBER:</u>	<u>ASSESSMENT NUMBER:</u>
SHEET 3	0001-0068
SHEET 4	0069-0111
SHEET 5	0112-0122
SHEET 6	0123-0128
SHEET 7	0129-0219
SHEET 8	0220-0374
SHEET 9	0375-0577
SHEET 10	0578
SHEET 11	0579-0609
SHEET 12	0610-0716
SHEET 13	0717-0957
SHEET 14	0958-1161
SHEET 15	1162-1193
SHEET 16	1194
SHEET 17	1195-1226
SHEET 18	1227-1283
SHEET 19	1284-1379
SHEET 20	1380-1484
SHEET 21	1485-1488

**ASSESSMENT
DIAGRAM**

NIPOMO MESA
SUPPLEMENTAL
ASSESSMENT DISTRICT
NO.1

NIPOMO COMMUNITY
SERVICES DISTRICT
STATE OF CALIFORNIA

Legend

-  ASSESSOR PARCEL
-  ASSESSOR PARCEL
-  ASSESSOR PARCEL

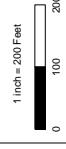

**SHEET:
5 OF 21**

3	4	5	6
7	8	9	10
11	12	13	14
15	16	17	18
19	20	21	

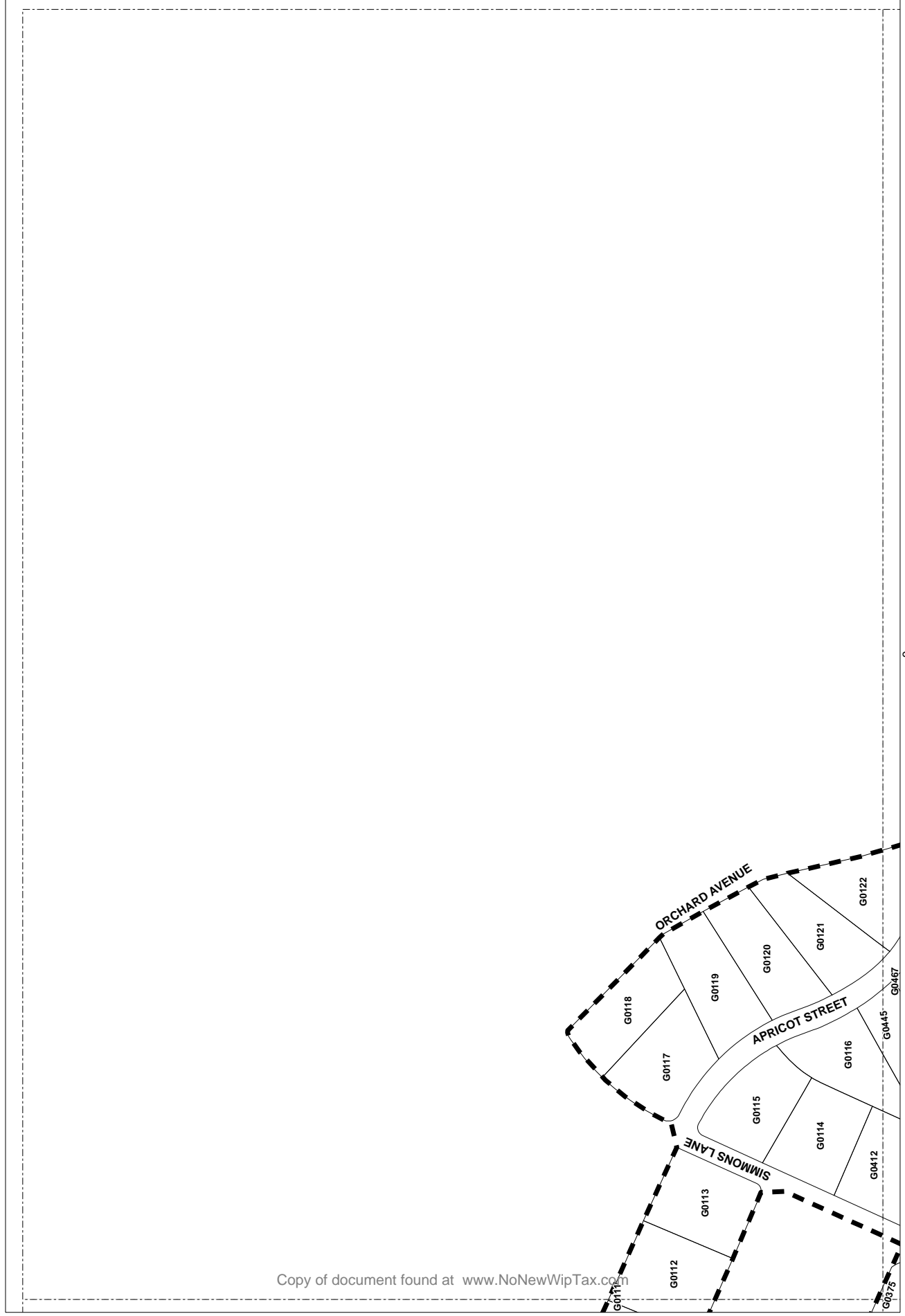

LOTS ON THIS SHEET ARE
BASED ON ASSESSORS
MAP COUNTY OF SAN LUIS
OBISPO, CA. BK. 090 PG. 271.
PAGES 103, 104, 105, 106, 107, 111, 122,
123, 124, 125, 126, 127, 128,
096, 097, 098, 101, 102, 103,
104, 105, 106, 107, 111, 122,
123, 124, 125, 126, 127, 128,
162, 172, 173, 174, 175, 181,
182, 183, 205, 206, 421, 422,
423, 424, 431, 432, 433, 434,
435, 436, 441, 442, 443,
446, 447, 448, 451, 452, 453,
462, 481, 501, 510, 511, 521,
541, 542, 546, 562, 563, 564.



**ASSESSMENT
DIAGRAM**

NIPOMO MESA
SUPPLEMENTAL
SERVICES DISTRICT
ASSESSMENT DISTRICT
NO.1

NIPOMO COMMUNITY
SERVICES DISTRICT
STATE OF CALIFORNIA

- Legend**
-  ASSM BOUNDARY
 -  ASSESSOR PARCEL
 -  DIAGRAM SHEET

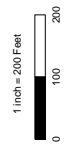

7

**SHEET:
6 OF 21**

3	4	5
7	8	9
11	12	13
17	18	19
20	21	

LOTS ON THIS SHEET ARE
BASED ON ASSESSORS'
MAP COUNTY OF SAN LUIS
OBISPO, CA, BK 090 PG 271,
PGS 001-002, 003, 004, 005, 006, 007, 008, 009, 010, 011, 012, 013, 014, 015, 016, 017, 018, 019, 020, 021,
022, 023, 024, 025, 026, 027, 028, 029, 030, 031, 032, 033, 034, 035, 036, 037, 038, 039, 040, 041, 042, 043, 044, 045, 046, 047, 048, 049, 050, 051, 052, 053, 054, 055, 056, 057, 058, 059, 060, 061, 062, 063, 064, 065, 066, 067, 068, 069, 070, 071, 072, 073, 074, 075, 076, 077, 078, 079, 080, 081, 082, 083, 084, 085, 086, 087, 088, 089, 090, 091, 092, 093, 094, 095, 096, 097, 098, 099, 100, 101, 102, 103, 104, 105, 106, 107, 111, 122, 123, 124, 125, 126, 127, 128, 129, 130, 131, 132, 133, 134, 135, 136, 137, 138, 139, 140, 141, 142, 143, 144, 145, 146, 147, 148, 149, 150, 151, 152, 153, 154, 155, 156, 157, 158, 159, 160, 161, 162, 172, 173, 174, 175, 181, 182, 183, 205, 206, 421, 422, 423, 424, 431, 432, 433, 434, 435, 436, 437, 438, 439, 440, 441, 442, 443, 444, 445, 446, 447, 448, 451, 452, 453, 454, 455, 456, 457, 472, 473, 482, 481, 501, 510, 511, 521, 541, 542, 546, 562, 563, 564,

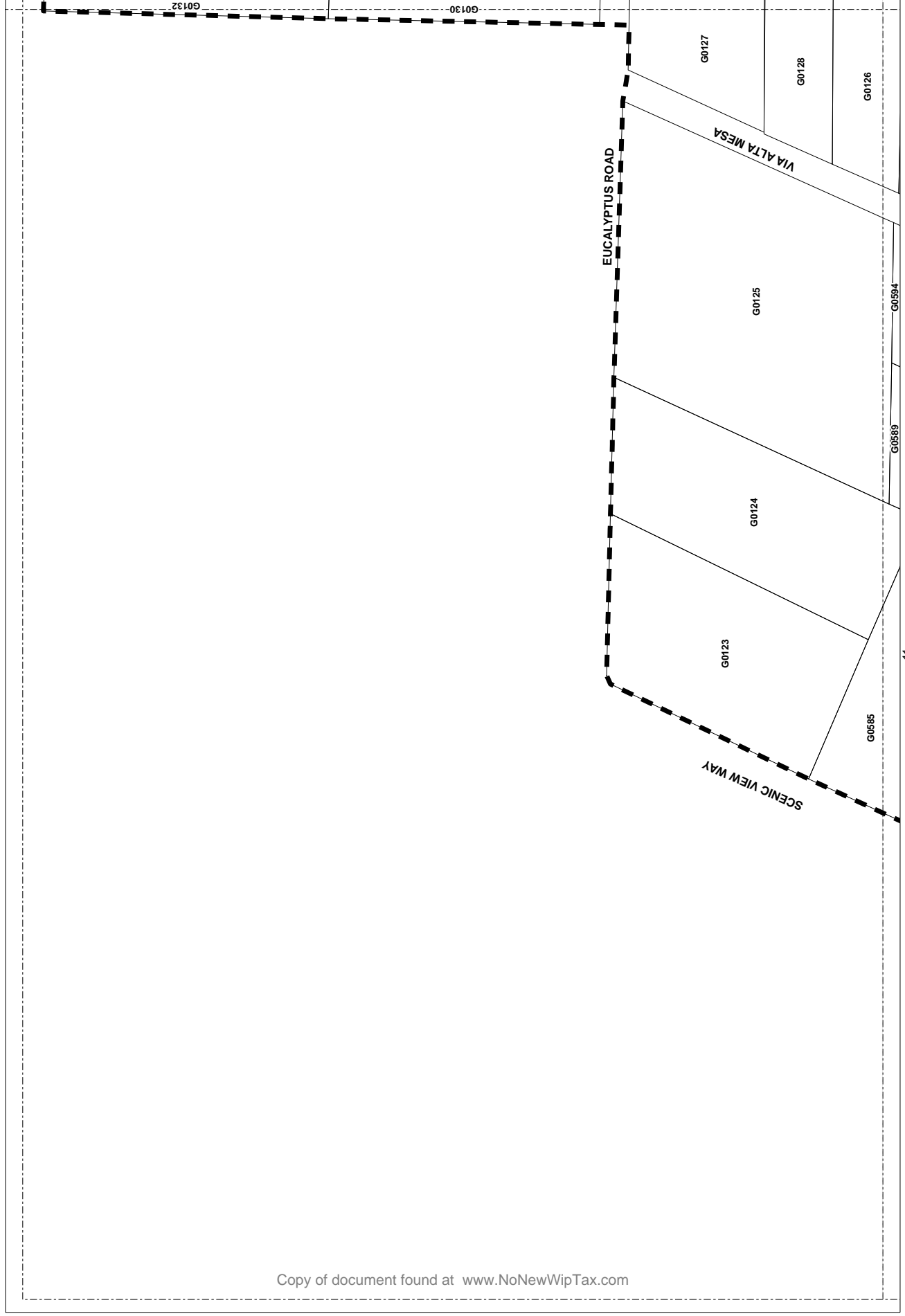



**ASSESSMENT
DIAGRAM**

NIPOMO MESA
SUPPLEMENTAL
SERVICES DISTRICT
ASSESSMENT DISTRICT
NO.1

NIPOMO COMMUNITY
SERVICES DISTRICT
STATE OF CALIFORNIA

Legend

-  ASSESSOR PARCEL
-  ASSESSOR PARCEL
-  ASSESSOR PARCEL

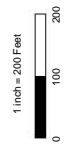

**SHEET:
10 OF 21**

3	4	5
6	7	8
9	10	11
12	13	14
15	16	17
18	19	20
21		

LOTS ON THIS SHEET ARE
BASED ON ASSESSORS
MAP COUNTY OF SAN LUIS
OBISPO, CA, BK 090 PG 271,
PGS 001-002, 003, 004, 005, 006, 007, 008, 009, 010, 011, 012,
013, 014, 015, 016, 017, 018, 019, 020, 021,
022, 023, 024, 025, 026, 027, 028, 029, 030, 031, 032,
033, 034, 035, 036, 037, 038, 039, 040, 041, 042, 043,
044, 045, 046, 047, 048, 049, 050, 051, 052, 053,
054, 055, 056, 057, 058, 059, 060, 061, 062, 063, 064,
065, 066, 067, 068, 069, 070, 071, 072, 073, 074, 075, 076,
077, 078, 079, 080, 081, 082, 083, 084, 085, 086, 087, 088,
089, 090, 091, 092, 093, 094, 095, 096, 097, 098, 099, 100,
101, 102, 103, 104, 105, 106, 107, 111, 122,
123, 124, 125, 126, 127, 128, 129, 130, 131, 132,
133, 134, 135, 136, 137, 138, 139, 140, 141, 142,
143, 144, 145, 146, 147, 148, 149, 150, 151, 152,
153, 154, 155, 156, 157, 158, 159, 160, 161, 162,
163, 164, 165, 166, 167, 168, 169, 170, 171, 172,
173, 174, 175, 176, 177, 178, 179, 180, 181, 182,
183, 184, 185, 186, 187, 188, 189, 190, 191, 192,
193, 194, 195, 196, 197, 198, 199, 200, 201, 202,
203, 204, 205, 206, 207, 208, 209, 210, 211, 212,
213, 214, 215, 216, 217, 218, 219, 220, 221, 222,
223, 224, 225, 226, 227, 228, 229, 230, 231, 232,
233, 234, 235, 236, 237, 238, 239, 240, 241, 242,
243, 244, 245, 246, 247, 248, 249, 250, 251, 252,
253, 254, 255, 256, 257, 258, 259, 260, 261, 262,
263, 264, 265, 266, 267, 268, 269, 270, 271, 272,
273, 274, 275, 276, 277, 278, 279, 280, 281, 282,
283, 284, 285, 286, 287, 288, 289, 290, 291, 292,
293, 294, 295, 296, 297, 298, 299, 300, 301, 302,
303, 304, 305, 306, 307, 308, 309, 310, 311, 312,
313, 314, 315, 316, 317, 318, 319, 320, 321, 322,
323, 324, 325, 326, 327, 328, 329, 330, 331, 332,
333, 334, 335, 336, 337, 338, 339, 340, 341, 342,
343, 344, 345, 346, 347, 348, 349, 350, 351, 352,
353, 354, 355, 356, 357, 358, 359, 360, 361, 362,
363, 364, 365, 366, 367, 368, 369, 370, 371, 372,
373, 374, 375, 376, 377, 378, 379, 380, 381, 382,
383, 384, 385, 386, 387, 388, 389, 390, 391, 392,
393, 394, 395, 396, 397, 398, 399, 400, 401, 402,
403, 404, 405, 406, 407, 408, 409, 410, 411, 412,
413, 414, 415, 416, 417, 418, 419, 420, 421, 422,
423, 424, 425, 426, 427, 428, 429, 430, 431, 432,
433, 434, 435, 436, 437, 438, 439, 440, 441, 442,
443, 444, 445, 446, 447, 448, 449, 450, 451, 452,
453, 454, 455, 456, 457, 472, 473, 474, 475, 476,
477, 478, 479, 480, 481, 482, 483, 484, 485, 486,
487, 488, 489, 490, 491, 492, 493, 494, 495, 496,
497, 498, 499, 500, 501, 502, 503, 504, 505, 506,
507, 508, 509, 510, 511, 512, 513, 514, 515, 516,
517, 518, 519, 520, 521, 522, 523, 524, 525, 526,
527, 528, 529, 530, 531, 532, 533, 534, 535, 536,
537, 538, 539, 540, 541, 542, 543, 544, 545, 546,
547, 548, 549, 550, 551, 552, 553, 554, 555, 556,
557, 558, 559, 560, 561, 562, 563, 564, 565, 566,
567, 568, 569, 570, 571, 572, 573, 574, 575, 576,
577, 578, 579, 580, 581, 582, 583, 584, 585, 586,
587, 588, 589, 590, 591, 592, 593, 594, 595, 596,
597, 598, 599, 600, 601, 602, 603, 604, 605, 606,
607, 608, 609, 610, 611, 612, 613, 614, 615, 616,
617, 618, 619, 620, 621, 622, 623, 624, 625, 626,
627, 628, 629, 630, 631, 632, 633, 634, 635, 636,
637, 638, 639, 640, 641, 642, 643, 644, 645, 646,
647, 648, 649, 650, 651, 652, 653, 654, 655, 656,
657, 658, 659, 660, 661, 662, 663, 664, 665, 666,
667, 668, 669, 670, 671, 672, 673, 674, 675, 676,
677, 678, 679, 680, 681, 682, 683, 684, 685, 686,
687, 688, 689, 690, 691, 692, 693, 694, 695, 696,
697, 698, 699, 700, 701, 702, 703, 704, 705, 706,
707, 708, 709, 710, 711, 712, 713, 714, 715, 716,
717, 718, 719, 720, 721, 722, 723, 724, 725, 726,
727, 728, 729, 730, 731, 732, 733, 734, 735, 736,
737, 738, 739, 740, 741, 742, 743, 744, 745, 746,
747, 748, 749, 750, 751, 752, 753, 754, 755, 756,
757, 758, 759, 760, 761, 762, 763, 764, 765, 766,
767, 768, 769, 770, 771, 772, 773, 774, 775, 776,
777, 778, 779, 780, 781, 782, 783, 784, 785, 786,
787, 788, 789, 790, 791, 792, 793, 794, 795, 796,
797, 798, 799, 800, 801, 802, 803, 804, 805, 806,
807, 808, 809, 810, 811, 812, 813, 814, 815, 816,
817, 818, 819, 820, 821, 822, 823, 824, 825, 826,
827, 828, 829, 830, 831, 832, 833, 834, 835, 836,
837, 838, 839, 840, 841, 842, 843, 844, 845, 846,
847, 848, 849, 850, 851, 852, 853, 854, 855, 856,
857, 858, 859, 860, 861, 862, 863, 864, 865, 866,
867, 868, 869, 870, 871, 872, 873, 874, 875, 876,
877, 878, 879, 880, 881, 882, 883, 884, 885, 886,
887, 888, 889, 890, 891, 892, 893, 894, 895, 896,
897, 898, 899, 900, 901, 902, 903, 904, 905, 906,
907, 908, 909, 910, 911, 912, 913, 914, 915, 916,
917, 918, 919, 920, 921, 922, 923, 924, 925, 926,
927, 928, 929, 930, 931, 932, 933, 934, 935, 936,
937, 938, 939, 940, 941, 942, 943, 944, 945, 946,
947, 948, 949, 950, 951, 952, 953, 954, 955, 956,
957, 958, 959, 960, 961, 962, 963, 964, 965, 966,
967, 968, 969, 970, 971, 972, 973, 974, 975, 976,
977, 978, 979, 980, 981, 982, 983, 984, 985, 986,
987, 988, 989, 990, 991, 992, 993, 994, 995, 996,
997, 998, 999, 1000

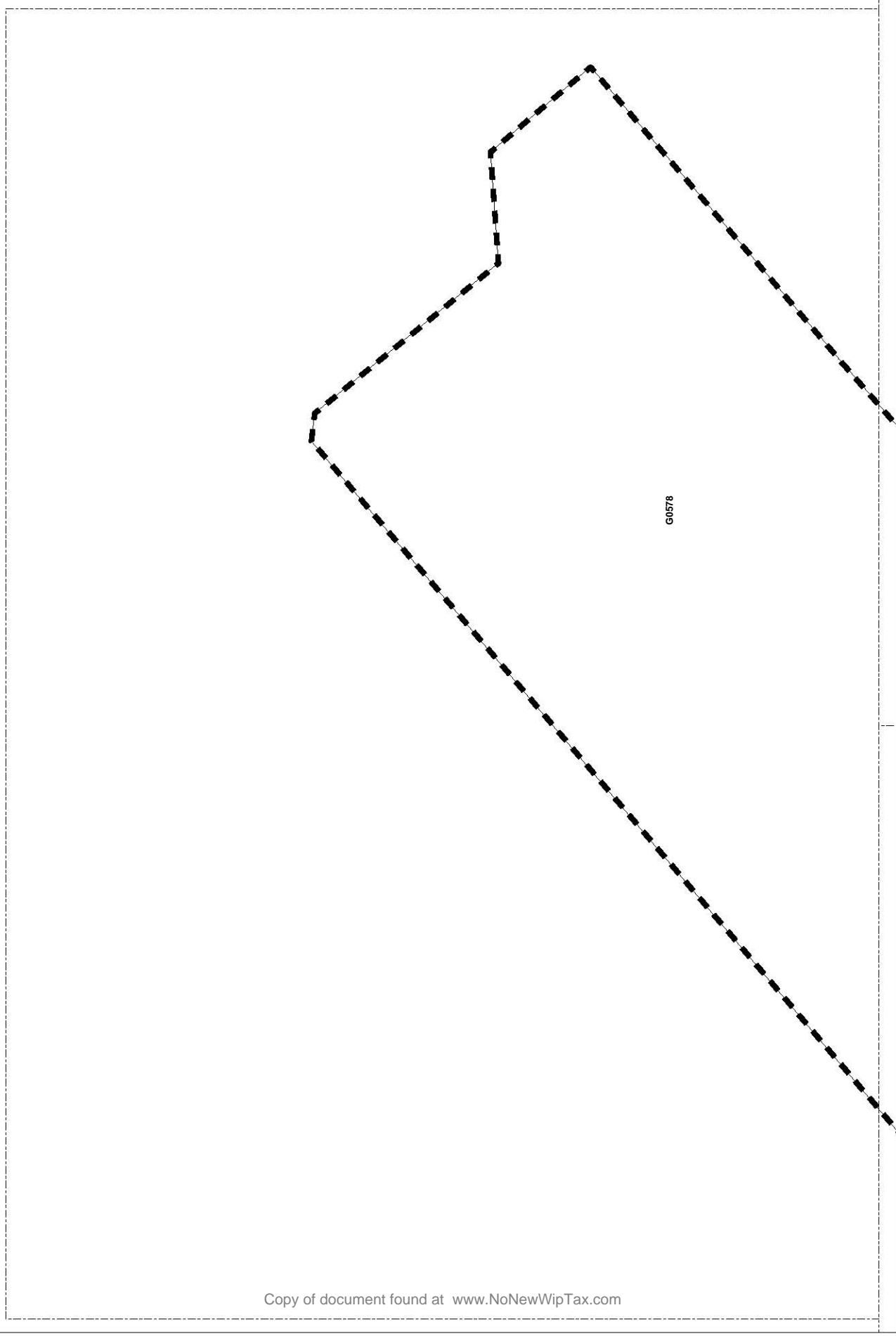



16

15

**ASSESSMENT
DIAGRAM**

NIPOMO MESA
SUPPLEMENTAL
ASSASSMENT DISTRICT
NO.1
NIPOMO COMMUNITY
SERVICES DISTRICT
STATE OF CALIFORNIA

- Legend**
-  ASSM BOUNDARY
 -  ASSESSOR PARCEL
 -  DIAGRAM SHEET

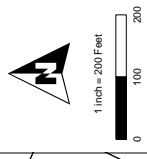

**SHEET:
11 OF 21**

3	4	5
6	7	8
9	10	11
12	13	14
15	16	17
18	19	20
21		

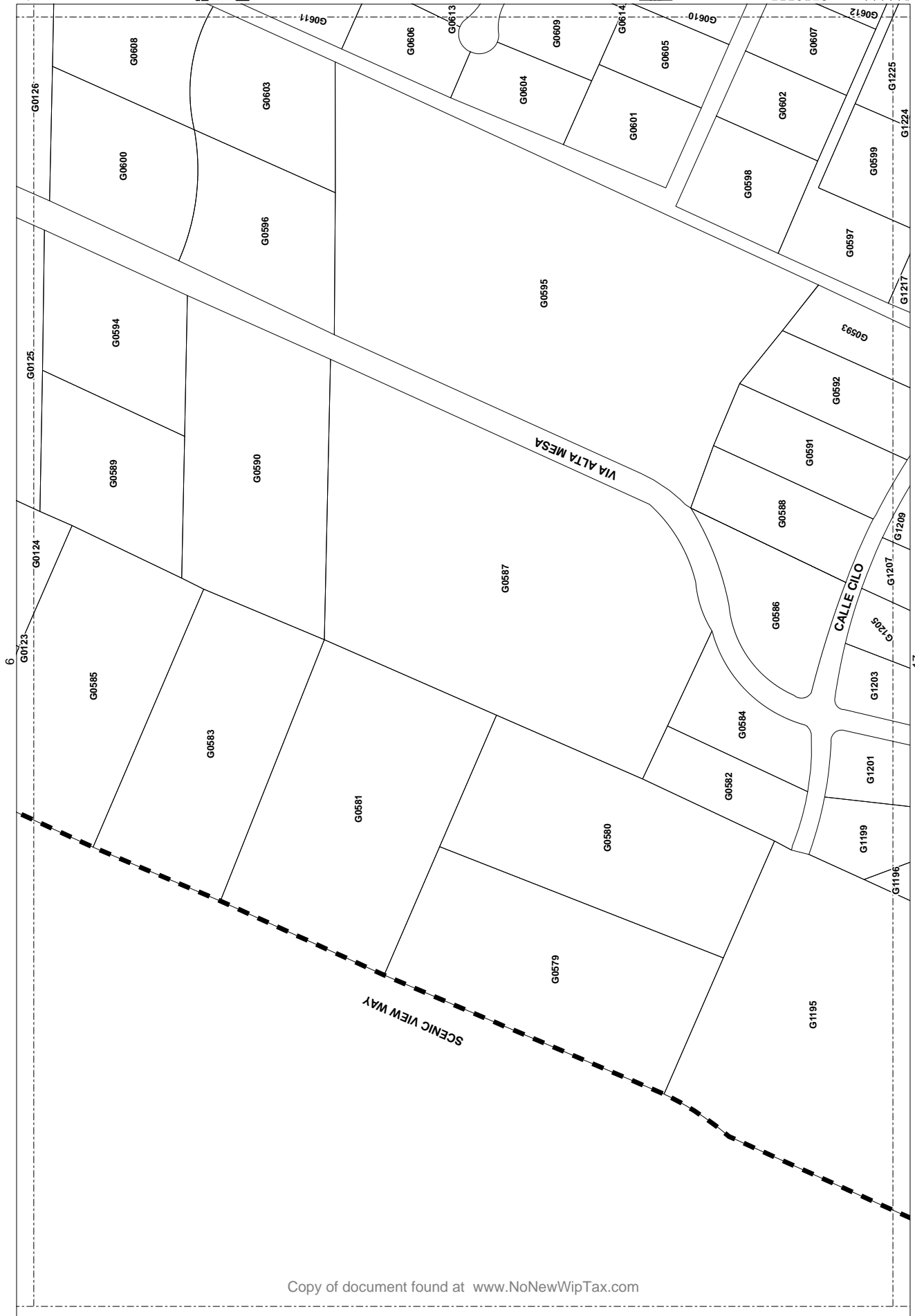

LOTS ON THIS SHEET ARE
BASED ON ASSESSORS
MAP COUNTY OF SAN LUIS
OBISPO, CA, BK 060 PG 271,
060 PG 272, 060 PG 273,
060 PG 274, 060 PG 275,
060 PG 276, 060 PG 277,
060 PG 278, 060 PG 279,
060 PG 280, 060 PG 281,
060 PG 282, 060 PG 283,
060 PG 284, 060 PG 285,
060 PG 286, 060 PG 287,
060 PG 288, 060 PG 289,
060 PG 290, 060 PG 291,
060 PG 292, 060 PG 293,
060 PG 294, 060 PG 295,
060 PG 296, 060 PG 297,
060 PG 298, 060 PG 299,
060 PG 300, 060 PG 301,
060 PG 302, 060 PG 303,
060 PG 304, 060 PG 305,
060 PG 306, 060 PG 307,
060 PG 308, 060 PG 309,
060 PG 310, 060 PG 311,
060 PG 312, 060 PG 313,
060 PG 314, 060 PG 315,
060 PG 316, 060 PG 317,
060 PG 318, 060 PG 319,
060 PG 320, 060 PG 321,
060 PG 322, 060 PG 323,
060 PG 324, 060 PG 325,
060 PG 326, 060 PG 327,
060 PG 328, 060 PG 329,
060 PG 330, 060 PG 331,
060 PG 332, 060 PG 333,
060 PG 334, 060 PG 335,
060 PG 336, 060 PG 337,
060 PG 338, 060 PG 339,
060 PG 340, 060 PG 341,
060 PG 342, 060 PG 343,
060 PG 344, 060 PG 345,
060 PG 346, 060 PG 347,
060 PG 348, 060 PG 349,
060 PG 350, 060 PG 351,
060 PG 352, 060 PG 353,
060 PG 354, 060 PG 355,
060 PG 356, 060 PG 357,
060 PG 358, 060 PG 359,
060 PG 360, 060 PG 361,
060 PG 362, 060 PG 363,
060 PG 364, 060 PG 365,
060 PG 366, 060 PG 367,
060 PG 368, 060 PG 369,
060 PG 370, 060 PG 371,
060 PG 372, 060 PG 373,
060 PG 374, 060 PG 375,
060 PG 376, 060 PG 377,
060 PG 378, 060 PG 379,
060 PG 380, 060 PG 381,
060 PG 382, 060 PG 383,
060 PG 384, 060 PG 385,
060 PG 386, 060 PG 387,
060 PG 388, 060 PG 389,
060 PG 390, 060 PG 391,
060 PG 392, 060 PG 393,
060 PG 394, 060 PG 395,
060 PG 396, 060 PG 397,
060 PG 398, 060 PG 399,
060 PG 400, 060 PG 401,
060 PG 402, 060 PG 403,
060 PG 404, 060 PG 405,
060 PG 406, 060 PG 407,
060 PG 408, 060 PG 409,
060 PG 410, 060 PG 411,
060 PG 412, 060 PG 413,
060 PG 414, 060 PG 415,
060 PG 416, 060 PG 417,
060 PG 418, 060 PG 419,
060 PG 420, 060 PG 421,
060 PG 422, 060 PG 423,
060 PG 424, 060 PG 425,
060 PG 426, 060 PG 427,
060 PG 428, 060 PG 429,
060 PG 430, 060 PG 431,
060 PG 432, 060 PG 433,
060 PG 434, 060 PG 435,
060 PG 436, 060 PG 437,
060 PG 438, 060 PG 439,
060 PG 440, 060 PG 441,
060 PG 442, 060 PG 443,
060 PG 444, 060 PG 445,
060 PG 446, 060 PG 447,
060 PG 448, 060 PG 449,
060 PG 450, 060 PG 451,
060 PG 452, 060 PG 453,
060 PG 454, 060 PG 455,
060 PG 456, 060 PG 457,
060 PG 458, 060 PG 459,
060 PG 460, 060 PG 461,
060 PG 462, 060 PG 463,
060 PG 464, 060 PG 465,
060 PG 466, 060 PG 467,
060 PG 468, 060 PG 469,
060 PG 470, 060 PG 471,
060 PG 472, 060 PG 473,
060 PG 474, 060 PG 475,
060 PG 476, 060 PG 477,
060 PG 478, 060 PG 479,
060 PG 480, 060 PG 481,
060 PG 482, 060 PG 483,
060 PG 484, 060 PG 485,
060 PG 486, 060 PG 487,
060 PG 488, 060 PG 489,
060 PG 490, 060 PG 491,
060 PG 492, 060 PG 493,
060 PG 494, 060 PG 495,
060 PG 496, 060 PG 497,
060 PG 498, 060 PG 499,
060 PG 500, 060 PG 501,
060 PG 502, 060 PG 503,
060 PG 504, 060 PG 505,
060 PG 506, 060 PG 507,
060 PG 508, 060 PG 509,
060 PG 510, 060 PG 511,
060 PG 512, 060 PG 513,
060 PG 514, 060 PG 515,
060 PG 516, 060 PG 517,
060 PG 518, 060 PG 519,
060 PG 520, 060 PG 521,
060 PG 522, 060 PG 523,
060 PG 524, 060 PG 525,
060 PG 526, 060 PG 527,
060 PG 528, 060 PG 529,
060 PG 530, 060 PG 531,
060 PG 532, 060 PG 533,
060 PG 534, 060 PG 535,
060 PG 536, 060 PG 537,
060 PG 538, 060 PG 539,
060 PG 540, 060 PG 541,
060 PG 542, 060 PG 543,
060 PG 544, 060 PG 545,
060 PG 546, 060 PG 547,
060 PG 548, 060 PG 549,
060 PG 550, 060 PG 551,
060 PG 552, 060 PG 553,
060 PG 554, 060 PG 555,
060 PG 556, 060 PG 557,
060 PG 558, 060 PG 559,
060 PG 560, 060 PG 561,
060 PG 562, 060 PG 563,
060 PG 564,



**ASSESSMENT
DIAGRAM**

NIPOMO MESA
SUPPLEMENTAL
ASSESSMENT DISTRICT
NO.1

NIPOMO COMMUNITY
SERVICES DISTRICT
STATE OF CALIFORNIA

- Legend**
-  ASSESSOR PARCEL
 -  ASSESSOR PARCEL
 -  ASSESSOR PARCEL

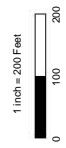

**SHEET:
16 OF 21**

3	4	5
6	7	8
9	10	11
12	13	14
15	16	17
18	19	20
21		

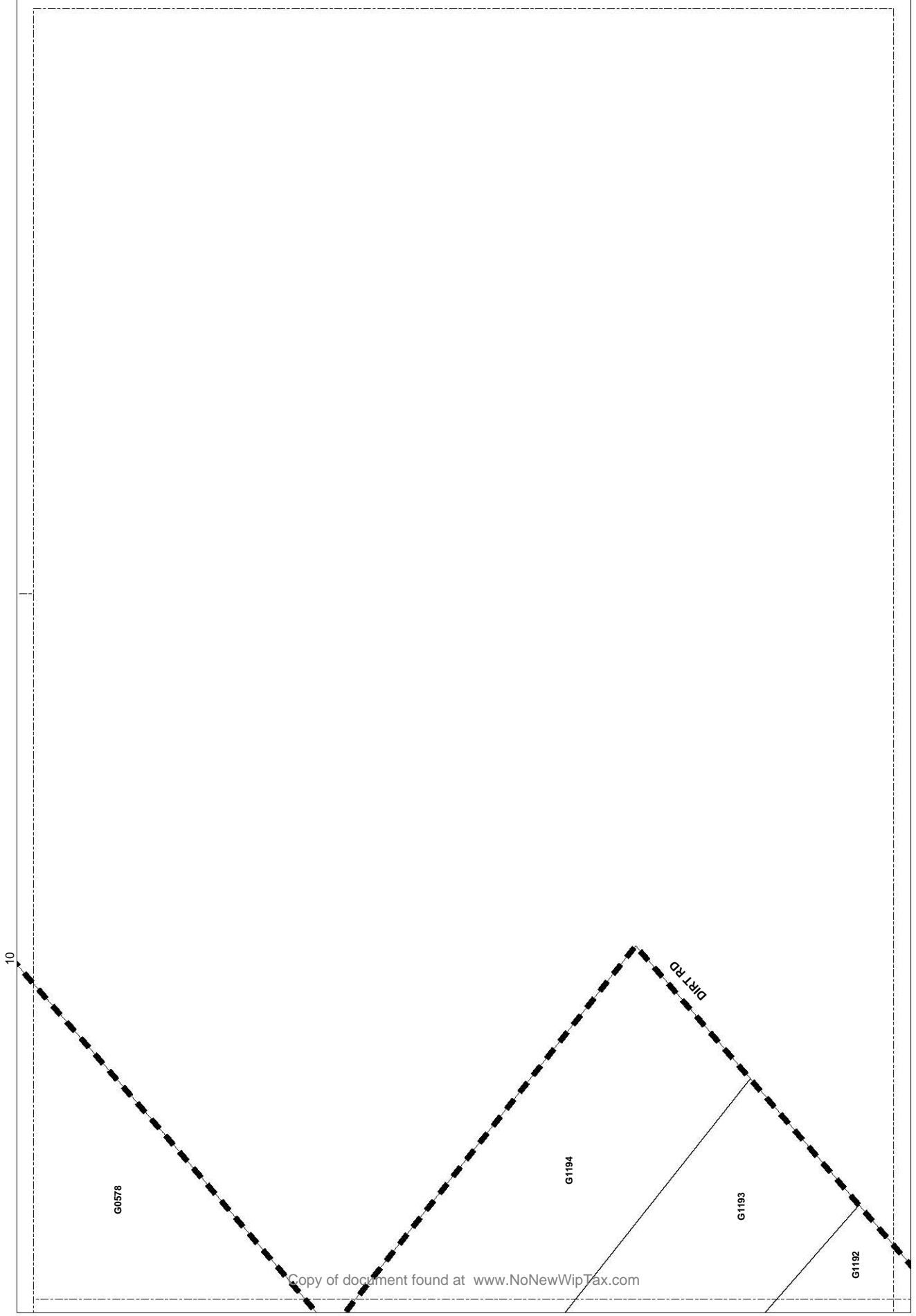

LOTS ON THIS SHEET ARE
BASED ON ASSESSORS
MAP COUNTY OF SAN LUIS
OBISPO, CA. BK 090 PG 271,
PGS 001-002, 003, 004, 005, 006, 007, 008, 009, 010, 011, 012, 013, 014, 015, 016, 017, 018, 019, 020, 021, 022, 023, 024, 025, 026, 027, 028, 029, 030, 031, 032, 033, 034, 035, 036, 037, 038, 039, 040, 041, 042, 043, 044, 045, 046, 047, 048, 049, 050, 051, 052, 053, 054, 055, 056, 057, 058, 059, 060, 061, 062, 063, 064, 065, 066, 067, 068, 069, 070, 071, 072, 073, 074, 075, 076, 077, 078, 079, 080, 081, 082, 083, 084, 085, 086, 087, 088, 089, 090, 091, 092, 093, 094, 095, 096, 097, 098, 099, 100, 101, 102, 103, 104, 105, 106, 107, 108, 109, 110, 111, 112, 113, 114, 115, 116, 117, 118, 119, 120, 121, 122, 123, 124, 125, 126, 127, 128, 129, 130, 131, 132, 133, 134, 135, 136, 137, 138, 139, 140, 141, 142, 143, 144, 145, 146, 147, 148, 149, 150, 151, 152, 153, 154, 155, 156, 157, 158, 159, 160, 161, 162, 163, 164, 165, 166, 167, 168, 169, 170, 171, 172, 173, 174, 175, 176, 177, 178, 179, 180, 181, 182, 183, 184, 185, 186, 187, 188, 189, 190, 191, 192, 193, 194, 195, 196, 197, 198, 199, 200, 201, 202, 203, 204, 205, 206, 207, 208, 209, 210, 211, 212, 213, 214, 215, 216, 217, 218, 219, 220, 221, 222, 223, 224, 225, 226, 227, 228, 229, 230, 231, 232, 233, 234, 235, 236, 237, 238, 239, 240, 241, 242, 243, 244, 245, 246, 247, 248, 249, 250, 251, 252, 253, 254, 255, 256, 257, 258, 259, 260, 261, 262, 263, 264, 265, 266, 267, 268, 269, 270, 271, 272, 273, 274, 275, 276, 277, 278, 279, 280, 281, 282, 283, 284, 285, 286, 287, 288, 289, 290, 291, 292, 293, 294, 295, 296, 297, 298, 299, 300, 301, 302, 303, 304, 305, 306, 307, 308, 309, 310, 311, 312, 313, 314, 315, 316, 317, 318, 319, 320, 321, 322, 323, 324, 325, 326, 327, 328, 329, 330, 331, 332, 333, 334, 335, 336, 337, 338, 339, 340, 341, 342, 343, 344, 345, 346, 347, 348, 349, 350, 351, 352, 353, 354, 355, 356, 357, 358, 359, 360, 361, 362, 363, 364, 365, 366, 367, 368, 369, 370, 371, 372, 373, 374, 375, 376, 377, 378, 379, 380, 381, 382, 383, 384, 385, 386, 387, 388, 389, 390, 391, 392, 393, 394, 395, 396, 397, 398, 399, 400, 401, 402, 403, 404, 405, 406, 407, 408, 409, 410, 411, 412, 413, 414, 415, 416, 417, 418, 419, 420, 421, 422, 423, 424, 425, 426, 427, 428, 429, 430, 431, 432, 433, 434, 435, 436, 437, 438, 439, 440, 441, 442, 443, 444, 445, 446, 447, 448, 449, 450, 451, 452, 453, 454, 455, 456, 457, 458, 459, 460, 461, 462, 463, 464, 465, 466, 467, 468, 469, 470, 471, 472, 473, 474, 475, 476, 477, 478, 479, 480, 481, 482, 483, 484, 485, 486, 487, 488, 489, 490, 491, 492, 493, 494, 495, 496, 497, 498, 499, 500, 501, 502, 503, 504, 505, 506, 507, 508, 509, 510, 511, 512, 513, 514, 515, 516, 517, 518, 519, 520, 521, 522, 523, 524, 525, 526, 527, 528, 529, 530, 531, 532, 533, 534, 535, 536, 537, 538, 539, 540, 541, 542, 543, 544, 545, 546, 547, 548, 549, 550, 551, 552, 553, 554, 555, 556, 557, 558, 559, 560, 561, 562, 563, 564.



Copy of document found at www.NoNewWipTax.com

**ASSESSMENT
DIAGRAM**

NIPOMO MESA
SUPPLEMENTAL
ASSessment DISTRICT
NO.1
NIPOMO COMMUNITY
SERVICES DISTRICT
STATE OF CALIFORNIA

- Legend**
-  ASSESSOR PARCEL
 -  ASSESSOR PARCEL
 -  DIAGRAM SHEET

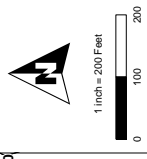

18

**SHEET:
17 OF 21**

3	4	5
6	7	8
9	10	11
12	13	14
15	16	17
18	19	20
21		

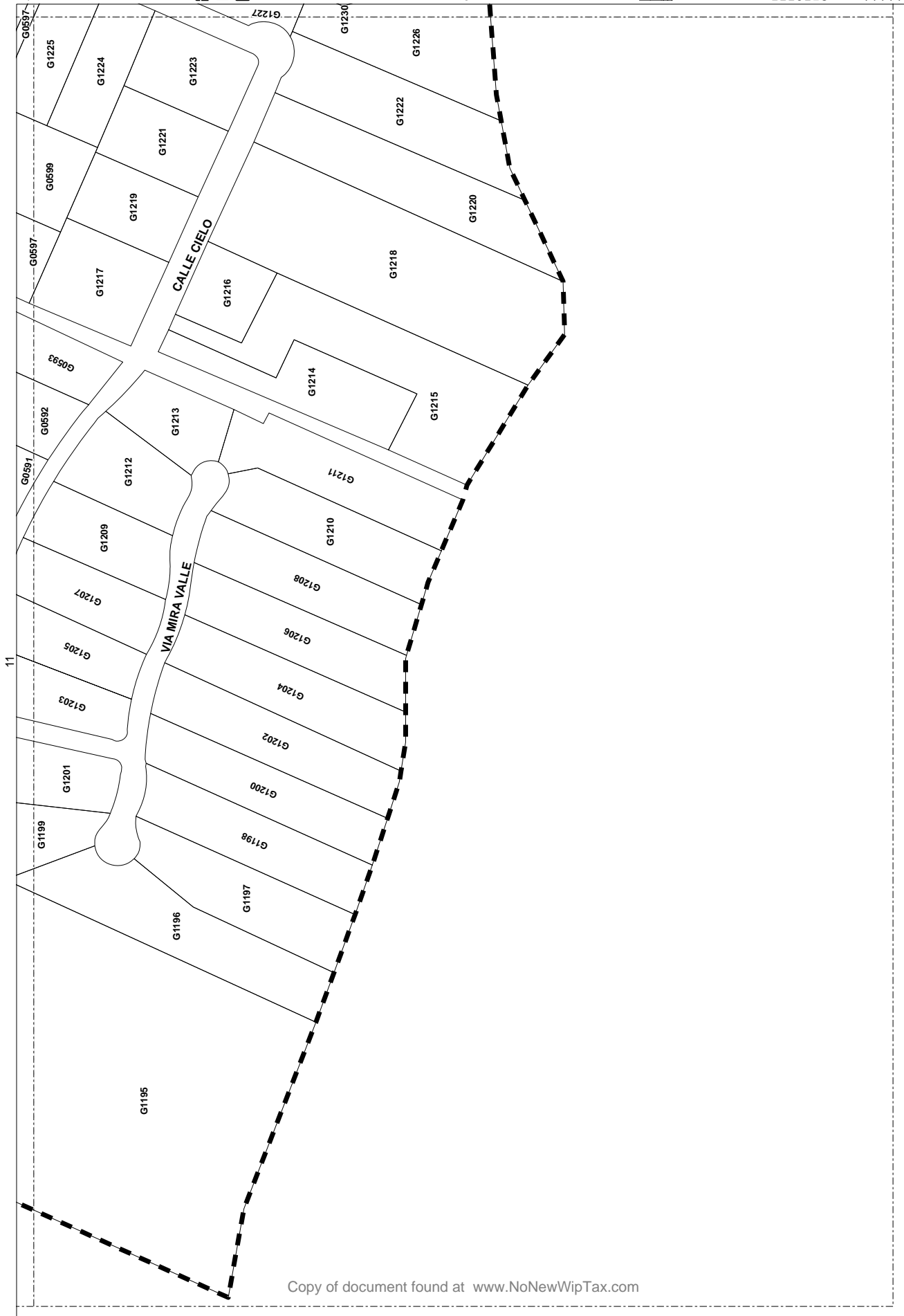

LOTS ON THIS SHEET ARE
BASED ON ASSESSORS'
MAP COUNTY OF SAN LUIS
OBISPO, CA, BK 090 PG 271,
PGS 001-002, 003, 004, 005, 006, 007, 008, 009, 010, 011, 012,
013, 014, 015, 016, 017, 018, 019, 020, 021,
022, 023, 024, 025, 026, 027, 028, 029, 030, 031,
032, 033, 034, 035, 036, 037, 038, 039, 040, 041,
042, 043, 044, 045, 046, 047, 048, 049, 050, 051,
052, 053, 054, 055, 056, 057, 058, 059, 060, 061,
062, 063, 064, 065, 066, 067, 068, 069, 070, 071,
072, 073, 074, 075, 076, 077, 078, 079, 080, 081,
082, 083, 084, 085, 086, 087, 088, 089, 090, 091,
092, 093, 094, 095, 096, 097, 098, 099, 100, 101,
102, 103, 104, 105, 106, 107, 108, 109, 110, 111,
112, 113, 114, 115, 116, 117, 118, 119, 120, 121,
122, 123, 124, 125, 126, 127, 128, 129, 130, 131,
132, 133, 134, 135, 136, 137, 138, 139, 140, 141,
142, 143, 144, 145, 146, 147, 148, 149, 150, 151,
152, 153, 154, 155, 156, 157, 158, 159, 160, 161,
162, 163, 164, 165, 166, 167, 168, 169, 170, 171,
172, 173, 174, 175, 176, 177, 178, 179, 180, 181,
182, 183, 184, 185, 186, 187, 188, 189, 190, 191,
192, 193, 194, 195, 196, 197, 198, 199, 200, 201,
202, 203, 204, 205, 206, 207, 208, 209, 210, 211,
212, 213, 214, 215, 216, 217, 218, 219, 220, 221,
222, 223, 224, 225, 226, 227, 228, 229, 230, 231,
232, 233, 234, 235, 236, 237, 238, 239, 240, 241,
242, 243, 244, 245, 246, 247, 248, 249, 250, 251,
252, 253, 254, 255, 256, 257, 258, 259, 260, 261,
262, 263, 264, 265, 266, 267, 268, 269, 270, 271,
272, 273, 274, 275, 276, 277, 278, 279, 280, 281,
282, 283, 284, 285, 286, 287, 288, 289, 290, 291,
292, 293, 294, 295, 296, 297, 298, 299, 300, 301,
302, 303, 304, 305, 306, 307, 308, 309, 310, 311,
312, 313, 314, 315, 316, 317, 318, 319, 320, 321,
322, 323, 324, 325, 326, 327, 328, 329, 330, 331,
332, 333, 334, 335, 336, 337, 338, 339, 340, 341,
342, 343, 344, 345, 346, 347, 348, 349, 350, 351,
352, 353, 354, 355, 356, 357, 358, 359, 360, 361,
362, 363, 364, 365, 366, 367, 368, 369, 370, 371,
372, 373, 374, 375, 376, 377, 378, 379, 380, 381,
382, 383, 384, 385, 386, 387, 388, 389, 390, 391,
392, 393, 394, 395, 396, 397, 398, 399, 400, 401,
402, 403, 404, 405, 406, 407, 408, 409, 410, 411,
412, 413, 414, 415, 416, 417, 418, 419, 420, 421,
422, 423, 424, 425, 426, 427, 428, 429, 430, 431,
432, 433, 434, 435, 436, 437, 438, 439, 440, 441,
442, 443, 444, 445, 446, 447, 448, 449, 450, 451,
452, 453, 454, 455, 456, 457, 458, 459, 460, 461,
462, 463, 464, 465, 466, 467, 468, 469, 470, 471,
472, 473, 474, 475, 476, 477, 478, 479, 480, 481,
482, 483, 484, 485, 486, 487, 488, 489, 490, 491,
492, 493, 494, 495, 496, 497, 498, 499, 500, 501,
502, 503, 504, 505, 506, 507, 508, 509, 510, 511,
512, 513, 514, 515, 516, 517, 518, 519, 520, 521,
522, 523, 524, 525, 526, 527, 528, 529, 530, 531,
532, 533, 534, 535, 536, 537, 538, 539, 540, 541,
542, 543, 544, 545, 546, 547, 548, 549, 550, 551,
552, 553, 554, 555, 556, 557, 558, 559, 560, 561,
562, 563, 564, 565, 566, 567, 568, 569, 570, 571,
572, 573, 574, 575, 576, 577, 578, 579, 580, 581,
582, 583, 584, 585, 586, 587, 588, 589, 590, 591,
592, 593, 594, 595, 596, 597, 598, 599, 600, 601,
602, 603, 604, 605, 606, 607, 608, 609, 610, 611,
612, 613, 614, 615, 616, 617, 618, 619, 620, 621,
622, 623, 624, 625, 626, 627, 628, 629, 630, 631,
632, 633, 634, 635, 636, 637, 638, 639, 640, 641,
642, 643, 644, 645, 646, 647, 648, 649, 650, 651,
652, 653, 654, 655, 656, 657, 658, 659, 660, 661,
662, 663, 664, 665, 666, 667, 668, 669, 670, 671,
672, 673, 674, 675, 676, 677, 678, 679, 680, 681,
682, 683, 684, 685, 686, 687, 688, 689, 690, 691,
692, 693, 694, 695, 696, 697, 698, 699, 700, 701,
702, 703, 704, 705, 706, 707, 708, 709, 710, 711,
712, 713, 714, 715, 716, 717, 718, 719, 720, 721,
722, 723, 724, 725, 726, 727, 728, 729, 730, 731,
732, 733, 734, 735, 736, 737, 738, 739, 740, 741,
742, 743, 744, 745, 746, 747, 748, 749, 750, 751,
752, 753, 754, 755, 756, 757, 758, 759, 760, 761,
762, 763, 764, 765, 766, 767, 768, 769, 770, 771,
772, 773, 774, 775, 776, 777, 778, 779, 780, 781,
782, 783, 784, 785, 786, 787, 788, 789, 790, 791,
792, 793, 794, 795, 796, 797, 798, 799, 800, 801,
802, 803, 804, 805, 806, 807, 808, 809, 810, 811,
812, 813, 814, 815, 816, 817, 818, 819, 820, 821,
822, 823, 824, 825, 826, 827, 828, 829, 830, 831,
832, 833, 834, 835, 836, 837, 838, 839, 840, 841,
842, 843, 844, 845, 846, 847, 848, 849, 850, 851,
852, 853, 854, 855, 856, 857, 858, 859, 860, 861,
862, 863, 864, 865, 866, 867, 868, 869, 870, 871,
872, 873, 874, 875, 876, 877, 878, 879, 880, 881,
882, 883, 884, 885, 886, 887, 888, 889, 890, 891,
892, 893, 894, 895, 896, 897, 898, 899, 900, 901,
902, 903, 904, 905, 906, 907, 908, 909, 910, 911,
912, 913, 914, 915, 916, 917, 918, 919, 920, 921,
922, 923, 924, 925, 926, 927, 928, 929, 930, 931,
932, 933, 934, 935, 936, 937, 938, 939, 940, 941,
942, 943, 944, 945, 946, 947, 948, 949, 950, 951,
952, 953, 954, 955, 956, 957, 958, 959, 960, 961,
962, 963, 964, 965, 966, 967, 968, 969, 970, 971,
972, 973, 974, 975, 976, 977, 978, 979, 980, 981,
982, 983, 984, 985, 986, 987, 988, 989, 990, 991,
992, 993, 994, 995, 996, 997, 998, 999, 1000



**ASSESSMENT
DIAGRAM**

NIPOMO MESA
SUPPLEMENTAL
ASSIGNMENT
ASSESSMENT DISTRICT
NO. 1
NIPOMO COMMUNITY
SERVICES DISTRICT
STATE OF CALIFORNIA

Legend

-  ASSM BOUNDARY
-  ASSESSOR PARCEL
-  DIAGRAM SHEET



1 inch = 200 Feet

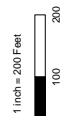

**SHEET:
18 OF 21**

3	4	5
6	7	8
9	10	11
12	13	14
15	16	17
18	19	20
21		

LOTS ON THIS SHEET ARE
BASED ON ASSESSORS'
MAP COUNTY OF SAN LUIS
OBISPO, CA, BK 060 PG 271,
PGS 001-002, 003, 004, 005, 006, 007, 008, 009, 010, 011, 012, 013, 014, 015, 016, 017, 018, 019, 020, 021, 022, 023, 024, 025, 026, 027, 028, 029, 030, 031, 032, 033, 034, 035, 036, 037, 038, 039, 040, 041, 042, 043, 044, 045, 046, 047, 048, 049, 050, 051, 052, 053, 054, 055, 056, 057, 058, 059, 060, 061, 062, 063, 064, 065, 066, 067, 068, 069, 070, 071, 072, 073, 074, 075, 076, 077, 078, 079, 080, 081, 082, 083, 084, 085, 086, 087, 088, 089, 090, 091, 092, 093, 094, 095, 096, 097, 098, 099, 100, 101, 102, 103, 104, 105, 106, 107, 111, 122, 123, 124, 125, 126, 127, 128, 129, 130, 131, 132, 133, 134, 135, 136, 137, 138, 139, 140, 141, 142, 143, 144, 145, 146, 147, 148, 149, 150, 151, 152, 153, 154, 155, 156, 157, 158, 159, 160, 161, 162, 172, 173, 174, 175, 181, 182, 183, 205, 206, 421, 422, 423, 424, 431, 432, 433, 434, 435, 436, 437, 438, 439, 440, 441, 442, 443, 444, 445, 446, 447, 448, 451, 452, 453, 454, 455, 456, 457, 472, 473, 482, 481, 501, 510, 511, 521, 541, 542, 546, 562, 563, 564.

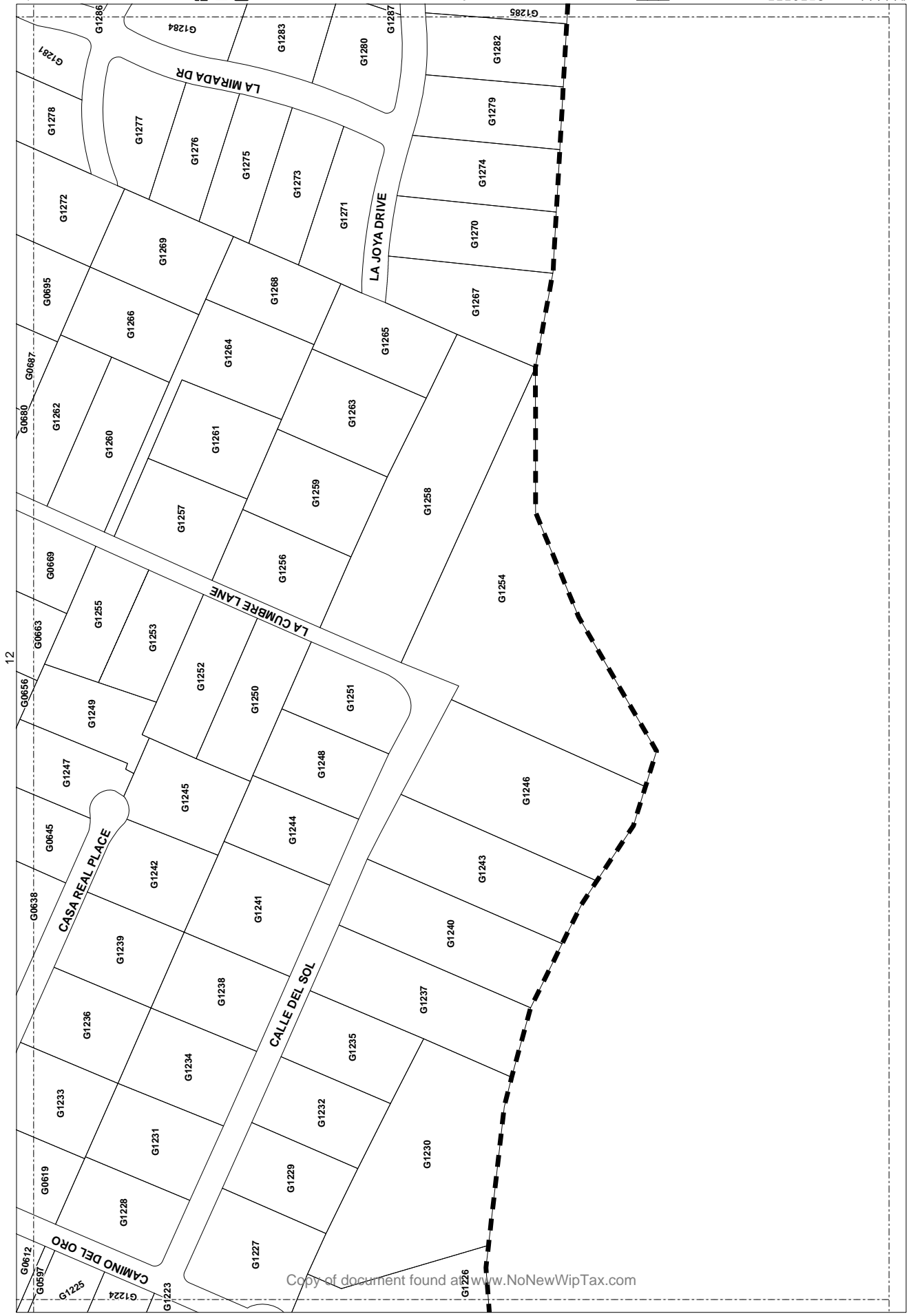

12

19

17

Property Owner Assessment Ballot

Nipomo Community Services District
Assessment District No. 2012-1 (Supplemental Water Project)

Please indicate your support of or opposition to the proposed assessment on your property by returning this Property Owner Assessment Ballot to the Secretary of the Nipomo Community Services District by _____, 2012.

- ① Read the enclosed information about the proposed Assessment District and the proposed assessment amount.
- ② Mark Yes or No on the backside of this ballot.
- ③ Sign your name and write the date in ink. (Unsigned ballots will not be counted. Only one property owner signature is required.)

- ④ Return the ballot in the envelope provided or deliver to:
Secretary
Nipomo Community Services District
148 South Wilson Street
Nipomo, CA 93444-0326

Completed ballots must be received by the Secretary no later than the close of the Public Hearing scheduled for ___00 p.m. on Wednesday, _____, 2012, at 148 South Wilson Street, Nipomo, CA 93444-0326. If you wrongly mark or deface this property owner assessment ballot, you may receive a replacement ballot by contacting the Secretary's office at 805-929-1133.

DRAFT BALLOT – FRONT SIDE

Property Owner Assessment Ballot
Nipomo Community Services District
Assessment District No. 2012-1 (Supplemental Water Project)

In order to preserve groundwater resources and increase water supply reliability in your parcel's geographic area, and to fund the construction and financing costs of a supplemental water project of benefit to your parcel, do you support the proposed assessment amount shown below for your property?

Yes, I SUPPORT the proposed assessment amount of \$<<F_Assmnt_Amt>> for my property for a supplemental water project.

No, I OPPOSE the proposed assessment amount of \$<<F_Assmnt_Amt>> for my property for a supplemental water project.



091,054,018 YES



091,054,018 NO

Property: APN No(s.) «APNs»
«New_Owner_First_Last»
«mailing»
«mailcity», «mailstate» «mailzip»

Signature: _____

Printed Name: _____

Date: _____

I hereby declare under penalty of perjury that I am a/the record owner of the parcel listed hereon. (Ballots must be marked and signed in ink to be counted. Only one property owner signature is required.)

**DRAFT BALLOT –
BACK SIDE**