

Harold Snyder  
P.O. Box 926  
Nipomo, CA 93444  
(805) 929-2455 H

October 7, 2011

Nipomo Community Services District  
148 Wilson Street  
P.O. Box 326  
Nipomo, CA 93444

(805) 929-1133 Phone  
(805) 929-1932 Fax

Dear Michael LeBrun:

At the 8/23/11 public presentation, in reference to the currently proposed "Water Intertie Project / Supplemental Water Project" you stated:

"1:28:20 Lebrun: so it's much more cost effective, especially when you look at the life cycle of operation this thing for 30 years.."

I searched the NCSD website for "life Cycle" and did not find any documents that relate to the "Life Cycle" "Costs" of the "Water Intertie Project / Supplemental Water Project"

I am making a public record request for a copy of the documentation of the "cost" for the "life cycle of operation" of the Water Intertie Project or Supplemental water project.

You state that it is "much more cost effective" so I am also requesting a copy of the documentation of the "Life Cycle" "Costs" of any alternatives that were used for comparison.

Thank You



Harold Snyder

RECEIVED

OCT 07 2011

NIPOMO COMMUNITY  
SERVICES DISTRICT

# NIPOMO COMMUNITY

## BOARD MEMBERS

JAMES HARRISON, PRESIDENT  
 LARRY VIERHEILIG, VICE PRESIDENT  
 MICHAEL WINN, DIRECTOR  
 ED EBY, DIRECTOR  
 DAN A. GADDIS, DIRECTOR



*Serving the Community Since 1965*

# SERVICES DISTRICT

## STAFF

MICHAEL S. LEBRUN, GENERAL MANAGER  
 LISA BOGNUDA, ASSISTANT GENERAL MANAGER  
 PETER SEVCIK, P.E., DISTRICT ENGINEER  
 TINA GRIETENS, UTILITY SUPERINTENDENT  
 JON SEITZ, GENERAL COUNSEL

148 SOUTH WILSON STREET POST OFFICE BOX 326 NIPOMO, CA 93444 - 0326  
 (805) 929-1133 FAX (805) 929-1932 Website address: ncsd.ca.gov

October 14, 2011

Mr. Harold Snyder  
 P. O. Box 926  
 Nipomo, California 93444  
 kochcal@earthlink.net

Dear Mr. Snyder:

**SUBJECT: OCTOBER 7, 2011 PUBLIC DOCUMENT REQUEST**

In responding to the public document request dated and received in the District office on October 7, 2011 (Attached). We have printed an excerpt of Attachment 7 of the San Luis Obispo County Integrated Proposal for State of California Department of Water Resources IRWM Proposition 84 Round 1 Implementation Grant, submitted January 2011.

There are 45 pages contained in this excerpt and the fee for copying is \$10.30.

\*\*\*\*\*  
 \* Nipomo CSD \*  
 \*\*\*\*\*

Very truly yours,

NIPOMO COMMUNITY SERVICES DISTRICT

Michael S. LeBrun  
 General Manager

148 S Wilson, PO Box 326  
 Nipomo, CA. 93444

Enclosure(s):

- 111007 Snyder Request

October 14, 2011 Receipt #.: 73959  
 Friday 2:40 pm Register #: 000  
 By: KATHY Terminal ID: 70

COPIES 10.30  
 Total 10.30  
 Check #  
 Check Amt...: .00  
 Cash.....: 10.30  
 Amt Tendered: 10.30  
 Total Paid...: 10.30  
 Change.....: .00  
 Paid By.: SNYDER

## San Luis Obispo County Integrated Proposal Economic Analysis – Water Supply Costs and Benefits

Attachment 7 describes, calculates, and documents the high value of the water supply benefits that will be delivered by the San Luis Obispo County Integrated Proposal (SLOCIP). The projects in this proposal that deliver water supply benefits are:

- Project Number 2. Los Osos Community Wastewater Project
- Project Number 4. Nipomo Waterline Intertie Project

As will be documented in this Attachment, both projects are shown to be beneficial to the local area, region, and State. Table 7-1 summarizes the total water supply benefits for the projects which total \$163,304,242, all attributable to the avoided project costs. The individual project costs as compared to the individual project benefits demonstrate the economic feasibility of each project as well as the overall proposal's economic feasibility.

This Attachment begins with a brief summary of the current state of the water supply and water quality in the San Luis Obispo region. Following that, both projects are analyzed for water supply benefits.

**Table 7-1 Monetized Benefits of Proposal Projects**

San Luis Obispo County Integrated Proposal				
Project	Total Discounted Water Supply Benefits	Total Discounted Avoided Project Costs	Other Discounted Water Supply Benefits	Total Present Value of Discounted Benefits
		Present Value		
Project Number 2. Los Osos Community Wastewater Project	\$0	\$65,337,940	\$0	\$65,337,940
Project Number 4. Nipomo Waterline Intertie Project	\$0	\$97,966,302	\$0	\$97,966,302
<b>Grand Total</b>	<b>\$0</b>	<b>\$163,304,242</b>	<b>\$0</b>	<b>\$163,304,242</b>

## Regional Water Supply Background

San Luis Obispo County obtains nearly 80 percent of its water from groundwater supplies and about 20 percent from reservoirs and other sources. Figure 7-1 illustrates the region’s water supplies. From a regional perspective, the status of overall water supplies within the San Luis Region and their ability to meet projected demand over the next 20 years has improved dramatically with the 2004 decisions to implement the Nacimiento Water Project. Other water supply reliability concerns still continue – those that are in the more urban areas of the region are relatively “small quantity” needs for the communities of Arroyo Grande, Grover Beach and Morro Bay – all of whom have existing infrastructure connections to at least two surface water supplies in addition to their existing groundwater facilities. Thus, while those communities are developing alternatives and recommendations to meet their needs, the communities are in the meanwhile protected in emergencies and droughts as a result of existing facilities and opportunities for water transfers and exchanges.

**Figure 7-1 San Luis Obispo Regional Water Supplies**

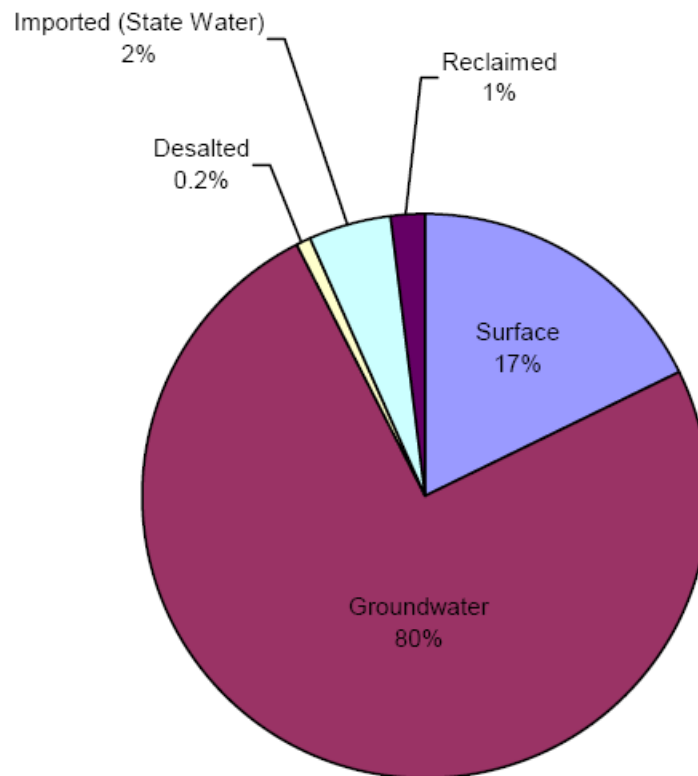

One of the highest priority water supply issues in the region is addressing the Santa Maria Groundwater Basin Adjudication. In 1997, the Santa Maria Valley Water Conservation District filed a groundwater adjudication lawsuit involving the Santa Maria Groundwater Basin that stretches from Orcutt to the South to Pismo Beach to the North (Figure 7-2). The greater Santa Maria Groundwater Basin includes waters underlying the Nipomo Mesa area (at the time commonly known as the Nipomo Hydrologic Sub-basin). The parties to the lawsuit included the City of Santa Maria, landowners and other water purveyors that pump groundwater from the Santa Maria Groundwater Basin including Nipomo Community Services District (NCSD), Woodlands Mutual Water Company (WMWC), Golden State Water Company (GSWC) and Rural Water Company (RWC).

Figure 7-2: Nipomo Mesa Management Area Water Purveyors

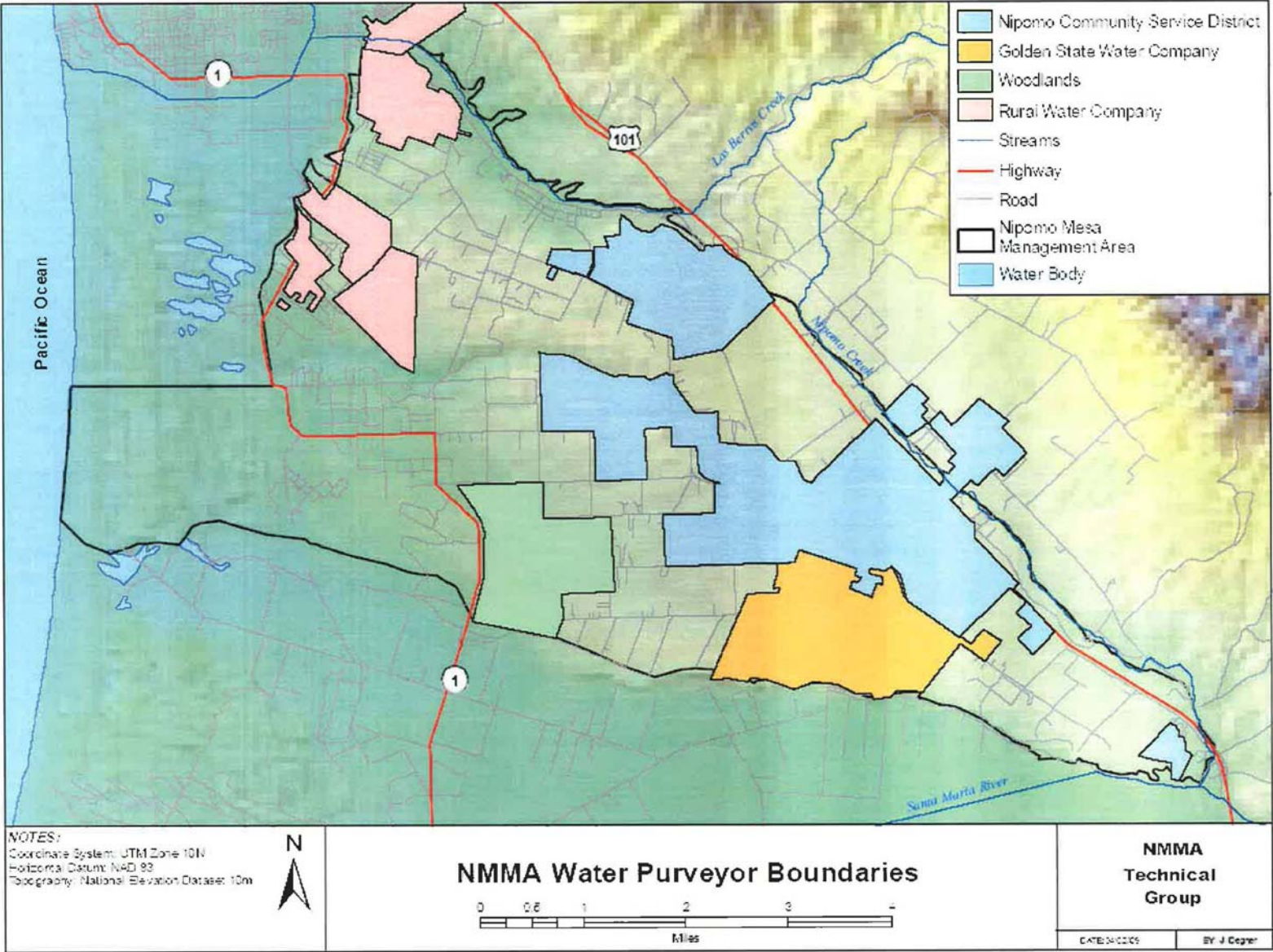

Subsequently, many of the parties including NCSO, WMWC, GSWC, City of Santa Maria, and County of San Luis Obispo signed a June 30, 2005, Stipulation (the “Stipulation”). The Stipulation was approved by the Court and the parties were ordered to comply with the terms of the Stipulation. The Stipulation divides the Santa Maria Groundwater Basin into three management areas known as the Santa Maria Valley Management Area (Southern portion of the Groundwater Basin) the Nipomo Mesa Management Area (the NMMA) (the center portion of the Groundwater Basin) and the Northern Cities Management Area (the northern portion of the Groundwater Basin).

Pursuant to the Stipulation, WMWC, GSWC and RWC agreed to participate in the Nipomo Waterline Intertie Project that is the subject of the 2004 MOU. The Nipomo Waterline Intertie Project will import water from the City of Santa Maria in Santa Barbara County to the community of Nipomo. Currently groundwater is the only water source in Nipomo and this supply is approaching its limit. The San Luis Region has water supply opportunities not available to individual water suppliers within the Region. Water suppliers that form partnerships with other entities in the region can accomplish projects that provide benefits that no single agency could do alone. The NCSO partnership with the City of Santa Maria on the Nipomo Waterline Intertie Project will improve water supply reliability by establishing a connection with the neighboring water supply; increase operational flexibility by participating in regional groundwater management and conjunctive use; protect water quality by participating in regional watershed management; reduce costs by cooperating with other agencies on water conservation and outreach programs; and alleviate groundwater conflicts in the Region.

While the Los Osos community gained notoriety for its water quality challenges, the Los Osos Community Wastewater Project is designed to provide water supply benefits to the region. The project will include recycling of all collected wastewater and reusing it within the limits of the groundwater basin. The recycled water reuse plan is being developed as part of an inter-agency groundwater basin management plan that includes agency inter-ties and water exchange and cooperative monitoring and water conservation efforts. With project implementation, reclaimed water will be approximately 30% of urban water demand.

## **Regional Water Quality Background**

The waters in the San Luis Region have the good fortune of being exposed to fewer pollutants than many of the urban areas of the State. However, despite the high quality water in many areas, the region also has some notable water quality challenges. Specific wastewater systems have been facing compliance challenges, other areas are exposed to groundwater pollutants from septic systems and other activities, and coastal areas are impacted by seawater intrusion.

The region’s most notable – perhaps “notorious” – project is the Los Osos Wastewater Project, embroiled in decades of local debate and deliberation. Nitrate contamination of drinking water supplies is a pervasive and serious problem in the Los Osos Community. The State MCL for nitrate in public drinking water is 45 mg/L, which is essentially equivalent to the federal MCL of 10 mg/L nitrite-nitrogen (nitrate-N). In 1991, EPA set additional MCLs for nitrite – N (1 mg/L) and for total nitrate and nitrite N (10 mg/L). In Los Osos, the upper basin is no longer useable without treatment due to nitrate contamination. The current average nitrate level is 12.5 mg/l (as N). Additionally, the community of Los Osos has been subject to seawater intrusion. The impact of the intrusion has recently been estimated to be migrating 100 feet per year.

Recent studies prepared by the County indicated that there is both a strong potential for seawater intrusion into the Nipomo area and that intrusion may already be occurring. The Nipomo Waterline Intertie Project will improve these groundwater conditions by importing water that allows in-lieu recharge of the groundwater basin thereby increasing groundwater elevations and helping protect against seawater intrusion.

## **Project Synergies**

Whether a public water system relies on surface water, groundwater, or a combination of the two, prevention of contamination is one of the most cost-effective methods of ensuring safe drinking water supplies. If source water becomes contaminated, expensive treatment or replacement of the water source may be required before safe drinking water can be delivered to users. The increased treatment or replacement costs are then passed on to users served by the public water system. The Los Osos Community Wastewater Project and the Nipomo Waterline Intertie Project are two of the highest water resources projects identified in the San Luis Obispo IRWMP. Both

projects protect the groundwater resources from future contamination and provide critically needed reliable local water supply resources.

### **Water Supply Synergies**

The goal of the Water Supply Program is to improve regional water supply reliability and security, reduce dependence on imported water, reduce water rights disputes and protect watershed communities from drought with a focus on interagency conjunctive use of regional water resources without unfairly burdening communities, neighborhoods or individuals.

The Nipomo Waterline Intertie Project will import water from the City of Santa Maria in Santa Barbara County to the community of Nipomo. The Nipomo Community Services District (NCSD) partnership with the City of Santa Maria on the project will improve water supply reliability by establishing a connection with the neighboring water supply; increase operational flexibility by participating in regional groundwater management and conjunctive use; protect water quality by participating in regional watershed management; reduce costs by cooperating with other agencies on water conservation and outreach programs; and alleviate groundwater conflicts in the Region. The Nipomo Waterline Intertie Project supports the following IRWMP Water Supply Program objective:

- Implement inter-agency projects including emergency inter-ties between systems, jointly developed facilities, water exchanges, and other methods of enhancing reliability through cooperative efforts over the development of new supplies.

The Los Osos Community Wastewater Project supports the following water supply objectives by recycling all collected wastewater and reusing it within the limits of the groundwater basin. The recycled water reuse plan is being developed as part of an inter-agency groundwater basin management plan that includes agency inter-ties and water exchange and cooperative monitoring and water conservation efforts. With project implementation, reclaimed water will be approximately 30% of urban water demand.

- Implement inter-agency projects including emergency inter-ties between systems, jointly developed facilities, water exchanges, and other methods of enhancing reliability through cooperative efforts over the development of new supplies.
- Expand reclaimed water use to make up 5% of total water use by 2010 and 10% of total water use by 2020.

### **Water Quality Synergies**

The goal of the Water Quality Program is to protect and improve water quality for beneficial uses consistent with regional interests and the Basin Plan in cooperation with local and state agencies and regional stakeholders without unfairly burdening communities, neighborhoods or individuals. The mission of the Los Osos Community Wastewater Project is to develop a wastewater treatment system for Los Osos, in cooperation with the community water purveyors, to solve the high-level water resource shortage and groundwater pollution problem, in an environmentally sustainable and cost effective manner, while respecting community preferences and promoting participatory government, and addressing individual affordability and environmental justice challenges to the greatest extent possible. The Los Osos Community Wastewater Project supports the following IRWMP Water Quality Program objectives:

- Protect and improve source water quality.
- Meet all federal and state drinking water standards.
- Support the development and implementation of TMDLs.
- Implement NPDES Phase II Storm Water Management Programs.
- Implement the California NPS Plan and the RWQCB Conditional Agricultural Waiver Program for irrigated agriculture.
- Comply with new waste discharge requirements.

The Nipomo Waterline Intertie Project primarily supports the following water quality objectives through the protection of the groundwater basin and the delivery of high quality drinking water:

- Protect and improve source water quality.
- Meet Drinking Water standards.

### **Groundwater Protection Synergies**

The goal of the Groundwater Monitoring and Management Program is to monitor, protect, and improve the regions groundwater through a collaborative approach designed to reduce conflicts without unfairly burdening communities, neighborhoods or individuals.

The Los Osos Community Wastewater Project supports the following groundwater objectives with the development of an inter-agency groundwater monitoring program as a component of the overall groundwater basin management plan. Groundwater monitoring reporting and requirements for adaptive management to address any adverse effects of the project are also required by the projects Coastal Development Permit.

- Develop monitoring and reporting programs for groundwater basins in the region.
- Protect and improve groundwater quality from point and non-point source pollution, including nitrate contamination; MTBE and other industrial, agricultural, and commercial sources of contamination; naturally occurring mineralization, boron, radionuclide, geothermal contamination; and seawater intrusion and salts.
- Conduct public education and outreach about ground water protection.
- Identify areas of known or expected conflicts and target stakeholders on specific actions that they should take to help protect groundwater basin quality and supply.
- Recharge ground water with high quality water.

The Nipomo Waterline Intertie Project will allow in-lieu recharge of the groundwater basin; alleviate groundwater conflicts in the Region through implementation of groundwater adjudication stipulated agreement requirements; and continue a rigorous groundwater monitoring and reporting program. NCSO manually measures groundwater levels in its production wells on a monthly basis. In addition, the District has installed a real-time level transducer in one of its production wells and based on the performance to date, is now planning on installing transducers in three additional production wells when the well pumps are pulled for repair or maintenance in the future. The level data is reported to SLO County as well as the Nipomo Mesa Management Area (NMMA) Technical Group that is responsible for preparing a report to the Court on an annual basis regarding the health of the groundwater basin. The NMMA Technical Group has developed a Key Well Index to track overall basin groundwater levels. This program will continue when the Nipomo Waterline Intertie Project comes on-line so that the impact of the project on the health of the basin can be monitored.

The Nipomo Waterline Intertie Project supports the following groundwater objectives:

- Develop monitoring and reporting programs for groundwater basins in the region.
- Evaluate and consider Groundwater Banking Programs.
- Protect and improve groundwater quality from point and non-point source pollution, including nitrate contamination; MTBE and other industrial, agricultural, and commercial sources of contamination; naturally occurring mineralization, boron, radionuclide, geothermal contamination; and seawater intrusion and salts.
- Conduct public education and outreach about ground water protection.
- Identify areas of known or expected conflicts and target stakeholders on specific actions that they should take to help protect groundwater basin quality and supply.
- Recharge ground water with high quality water.



## Los Osos Community Wastewater Project (Project Number 2)

The following water supply economic analysis for the Los Osos Community Wastewater Project has been developed according to the requirements outlined in the Proposition 84 Proposal Solicitation Package (PSP) and the guidelines document provided by the Department of Water Resources Division of Integrated Regional Water Management, and using available studies, reports, and technical documents. Components of the wastewater project are described in further detail in Attachment 3 of the Proposal.

### Introduction and Approach

In 1983, the Central Coast Regional Water Quality Control Board (RWQCB) established a wastewater prohibition zone in the coastal community of Los Osos. In 2006, the RWQCB issued a Cease and Desist Order ordering the discontinuation of septic discharges in certain urban areas of the community. In 2007, a Settlement Agreement and Order was developed by the RWQCB. The Settlement Agreement mandated the construction of a wastewater facility and elimination of septic discharges for the Los Osos Community. Failure to construct the wastewater facility would lead to penalties being imposed on each of the dischargers (septic tank owners). The approved Settlement Agreement and Order states:

The Parties acknowledge that pursuant to California Water Code section 13350, liability and remedies for violations of this Agreement are provided for including the authority of the Water Board to impose civil liability on a daily basis not to exceed \$5,000 against the Discharger for each day the violation occurs. However, the Parties agree that California Water Code section 13350(e)(1)A does not require the Water Board to impose a required minimum penalty of \$500 for each day of discharge.

The County of San Luis Obispo, through AB 2701, has undertaken the responsibility on a discretionary basis for developing a project that complies with the Settlement Agreement.

### *With Project Conditions*

The County developed the Los Osos Community Wastewater Project which complies with the Settlement Agreement and delivers the following water resources benefits:

- Reduction of nitrate concentrations in the upper groundwater basin of the community of Los Osos: The Basin Plan for Region 3 (Central Coast) identifies a number of beneficial uses for the Los Osos Groundwater Basin (Basin No. 3-8), including municipal use. However, the upper basin is no longer useable without treatment due to nitrate contamination. The current average nitrate level is 12.5 mg/l (as N). The proposed project will restore this beneficial use after a period of approximately 30 years based on previous water quality modeling efforts (Yates, 2003).
- Elimination of pathogen contamination source for Morro Bay Estuary: The Morro Bay Estuary has been identified as a 303(d) water quality limited water body for a number of contaminants, including pathogens. The EPA-approved list specifically identifies septic tank discharges as a source of pathogens. Fresh water seeps on the bay fringe have also been tested under a number of on-going monitoring programs (See Section 7), and bacterial limits for recreational use are periodically exceeded. The proposed project will eliminate a source of contamination for the estuary, and is expected to result in a measurable reduction in the fresh water bacteriological content of bay fringe seeps.
- Elimination of existing seawater intrusion and establishment of a sustainable water supply: The lower aquifer of the Los Osos Groundwater Basin is currently being degraded by approximately 450 ac-ft per year of seawater intrusion due to over pumping. The proposed project will provide an important source of reclaimed water for various recharge and re-use projects that will result in a balanced groundwater basin and will help mitigate seawater intrusion.

### *Without Project Conditions*

If the Los Osos Community Wastewater Project were not implemented by the County, an alternative project or projects would have to be developed and implemented that:

- Eliminated the septic discharges;
- Fully complied with all other regulatory requirements; and
- Delivered equivalent water supply benefits.

Until reasonable progress to eliminate septic discharges can be demonstrated to the RWQCB, the community can be subject to fines of \$5,000 per day per household as authorized in the Settlement Agreement.

Without the Los Osos Community Wastewater Project, the following conditions and approach are assumed to occur and are the basis for the without project conditions:

- Regional Board would fine all dischargers until adequate progress was made towards developing an alternative wastewater project. It is assumed that fines would be on the low end of the fine scale (\$500 per day per discharger), and be implemented for one year (the time it would take for another agency to demonstrate to the Regional Board they were making adequate progress towards construction).

In addition to the fines, alternative water resources projects would have to be developed to treat the contaminated groundwater, meet the water supply demands for the community, balance the basin, and mitigate seawater intrusion. The most feasible alternative projects, as identified in the Fine Screening Report, are

- Project A: Pump and Treat Nitrate Remediation
- Project B: Import State Water to Eliminate Seawater Intrusion

The two alternatives, implemented together, would provide the same level of water resource benefits as the Los Osos Community Wastewater Project.

For economic analysis, the avoided costs of the discharge penalties are considered in Attachment 8 – Water Quality Economics, and the avoided costs of Projects A and B are considered in Attachment 7 – Water Supply Economics. The total avoided cost will be the sum of the water supply and water quality avoided costs as specified in Attachment 10.

### **Economic Costs (With and Without Project)**

Costs considered in this economic analysis include initial implementation costs and estimated on-going costs associated with the administration, operation, and maintenance of the project, including replacement of project components. Even though the wastewater project is mandated by the state of California, both initial investments and on-going costs associated with the “without-project” alternatives that would be needed to accomplish full implementation of the project and achieve benefits identified in this analysis are considered. As outlined in the Proposition 84 guideline documents, costs reported in this economic analysis are consistent with costs reported in Attachment 4, and do not include sunk costs or costs spent in the past that have no recoverable value. Costs and benefits presented in the tables are expressed in 2009 dollars and are discounted according to the discount rates identified in the Proposition 84 PSP. Based on discussion with DWR’s representative, costs for financing the construction of projects should not be considered in this economic analysis and should be excluded from the economic analysis tables. Also, based on DWR’s guidance, costs reported for project administration, operation, maintenance, and replacement are reported in 2009 dollars and do not include assumed inflation during the project life cycle. A narrative description and associated cost details for the following project factors for with and without project conditions are included in this Attachment:

- Period of Economic Analysis
- Initial Project Costs

- Replacement Costs
- Operation & Maintenance Costs
- Water Supply Costs

### *Period of Economic Analysis (With and Without Project)*

The economic analysis for the Los Osos Wastewater Project and the ‘without-project’ alternatives are based on a project life cycle of 50 years, which is a commonly used life cycle for wastewater treatment facilities.

### *Initial Project Costs (With Project)*

Initial project costs for the wastewater project (see Table 7-2 on page 22) included in this economic analysis are based on the May 2010 Preliminary Engineers Report (PER) prepared for the United States Department of Agriculture, Rural Development (USDA). The PER was the basis for awarding over \$87 million in American Recovery & Reinvestment Act (ARRA) funds for the project, and the PER has been deemed adequate by the State Revolving Loan Fund staff (SRF) to use as an application for over \$80 million in SRF funds. Costs associated with the wastewater project are summarized in Attachment 4. In 2005 the project was designed, bid and partially constructed, with cost estimates used in this application developed from these actual bids.

### *Initial Project Costs (Without Project)*

Two alternative projects have been analyzed that correspond to the water supply benefits identified as a result of implementing a wastewater system. These projects would increase water supply by addressing nitrate remediation and seawater intrusion. Table 7-3 on page 24 summarizes the present worth of avoided projects that would provide similar water supply benefits in lieu of the project. Since the Regional Board’s order to construct a wastewater facility is based on water quality issues, the quantitative water quality impacts of “without project” are considered in Attachment 8. The alternative water supply projects are described in detail below.

#### **Project A: Pump and Treat Nitrate Remediation**

The geology of the upper aquifer has been extensively studied, including the ability to extract shallow groundwater and return recycled water. In addition, the mass quantity of nitrogen that will be removed from the basin has been estimated as part of the wastewater project design (Carollo, 2007). The water purveyors within the Los Osos community are currently considering implementing a nitrate removal system, with an estimated operations cost (including brine disposal) of approximately \$600/acre ft. through a service agreement with an independent vendor. This does not include operator labor and electrical power at the well head, which would be comparable to pumping from other sources. Preliminary cost estimates of the capital costs of infrastructure for blending and delivery are in the range of \$4.7 million. In order to provide the same volume of supply as recycled water, approximately 900 acre-ft per year would be pumped, treated for nitrates and blended with other potable water supplies. This alternative would provide similar water supply benefits as the wastewater project. However, without the removal of septic system discharges it is not expected to have an appreciable benefit to water quality.

#### **Project B: Import State Water to Eliminate Seawater Intrusion**

In lieu of 900 acre-ft of reclaimed water from the proposed project, State Water could be imported into Los Osos, if available. A number of recent studies have been completed that provide a basis for the estimated avoided cost as follows:

- The Fine Screening Report provides a basis for the annual water volume needed. In order to mitigate 450 acre-ft of seawater intrusion, an annual imported volume of 818 acre-ft would be required.
- In the Central Coast Region, the actual delivery of State Water averages 75% of the purchased entitlement, therefore a purchase of 1,090 acre-ft should be anticipated.
- The cost of pipeline facilities has been estimated in the Imported Water Technical Memorandum (See Exhibit 2N), and the cost construction is estimated at \$2,300,000.
- The cost to buy-in to existing State Water infrastructure was estimated in the Imported Water Technical Memorandum from \$15,000 to \$20,000 per acre-ft, which results in a conservative total of \$18 million.

*Replacement Costs (With Project)*

The USDA ARRA application required consideration of short-lived assets. A short-lived asset reserve schedule was developed in the PER and is summarized below. It is estimated that the annual replacement cost will be \$206,300.

*Replacement Costs (Without Project)*

Replacement costs for the without project alternatives were estimated to be 3% of total project costs. Estimated annual replacement costs for State Water were derived from the Imported Water Tech Memo and are estimated to be \$609,000. Replacement costs for well-head treatment are estimated to be \$141,000.

**Estimated 5, 10 and 15-Year Short-Lived Asset Reserve Schedule for Los Osos Wastewater Project**

Facility/Components	Overall Life Span	Service Age			Type of Service Required	Equipment Cost	Total	Total	Total
		5	10	15					
<b>Pocket Pump Stations</b>									
04A									
Grinder Pump No. 1	15		X		Unit Replacement	\$2,000	\$0	\$2,000	\$0
Grinder Pump No. 2	15			X	Unit Replacement	\$2,000	\$0	\$0	\$2,000
Grinder Pump No. 3	15			X	Unit Replacement	\$2,000	\$0	\$0	\$2,000
07A									
Grinder Pump No. 1	15		X		Unit Replacement	\$2,000	\$0	\$2,000	\$0
Grinder Pump No. 2	15			X	Unit Replacement	\$2,000	\$0	\$0	\$2,000
08A									
Grinder Pump No. 1	15		X		Unit Replacement	\$2,000	\$0	\$2,000	\$0
Grinder Pump No. 2	15			X	Unit Replacement	\$2,000	\$0	\$0	\$2,000
09A									
Grinder Pump No. 1	15		X		Unit Replacement	\$2,000	\$0	\$2,000	\$0
Grinder Pump No. 2	15			X	Unit Replacement	\$2,000	\$0	\$0	\$2,000
Grinder Pump No. 3	15			X	Unit Replacement	\$2,000	\$0	\$0	\$2,000
09B									
Grinder Pump No. 1	15		X		Unit Replacement	\$2,000	\$0	\$2,000	\$0
Grinder Pump No. 2	15			X	Unit Replacement	\$2,000	\$0	\$0	\$2,000
09C									
Grinder Pump No. 1	15		X		Unit Replacement	\$2,000	\$0	\$2,000	\$0
Grinder Pump No. 2	15			X	Unit Replacement	\$2,000	\$0	\$0	\$2,000
10A									
Grinder Pump No. 1	15		X		Unit Replacement	\$2,000	\$0	\$2,000	\$0
Grinder Pump No. 2	15			X	Unit Replacement	\$2,000	\$0	\$0	\$2,000
11A									
Grinder Pump No. 1	15		X		Unit Replacement	\$2,000	\$0	\$2,000	\$0
Grinder Pump No. 2	15			X	Unit Replacement	\$2,000	\$0	\$0	\$2,000

Facility/Components	Overall Life Span	Service Age			Type of Service Required	Equipment Cost	Total	Total	Total
		5	10	15					
12A									
Grinder Pump No. 1	15		X		Unit Replacement	\$2,000	\$0	\$2,000	\$0
Grinder Pump No. 2	15			X	Unit Replacement	\$2,000	\$0	\$0	\$2,000
13A									
Grinder Pump No. 1	15		X		Unit Replacement	\$2,000	\$0	\$2,000	\$0
Grinder Pump No. 2	15			X	Unit Replacement	\$2,000	\$0	\$0	\$2,000
13B									
Grinder Pump No. 1	15		X		Unit Replacement	\$2,000	\$0	\$2,000	\$0
Grinder Pump No. 2	15			X	Unit Replacement	\$2,000	\$0	\$0	\$2,000
15B									
Grinder Pump No. 1	15		X		Unit Replacement	\$2,000	\$0	\$2,000	\$0
Grinder Pump No. 2	15			X	Unit Replacement	\$2,000	\$0	\$0	\$2,000
Palisades									
Grinder Pump No. 1	15		X		Unit Replacement	\$2,000	\$0	\$2,000	\$0
Grinder Pump No. 2	15			X	Unit Replacement	\$2,000	\$0	\$0	\$2,000
Spare Pumps (All Pocket Pump Stations)									
Grinder Pump No. 1	15				Unit Replacement	\$2,000	\$0	\$0	\$0
Grinder Pump No. 2	15				Unit Replacement	\$2,000	\$0	\$0	\$0
Grinder Pump No. 3	15				Unit Replacement	\$2,000	\$0	\$0	\$0
Grinder Pump No. 4	15				Unit Replacement	\$2,000	\$0	\$0	\$0
Grinder Pump No. 5	15				Unit Replacement	\$2,000	\$0	\$0	\$0
<b>West Paso Pump Station</b>									
Pump No. 1	15		X		Unit Replacement	\$37,000	\$0	\$37,000	\$0
Pump No. 2	15			X	Unit Replacement	\$37,000	\$0	\$0	\$37,000
Pump No. 3	15			X	Unit Replacement	\$37,000	\$0	\$0	\$37,000
<b>East Paso Pump Station</b>									
Pump No. 1	15		X		Unit Replacement	\$7,100	\$0	\$7,100	\$0
Pump No. 2	15			X	Unit Replacement	\$7,100	\$0	\$0	\$7,100

Facility/Components	Overall Life Span	Service Age			Type of Service Required	Equipment Cost	Total	Total	Total
		5	10	15					
<b>Baywood Pump Station</b>									
Pump No. 1	15		X		Unit Replacement	\$4,300	\$0	\$4,300	\$0
Pump No. 2	15			X	Unit Replacement	\$4,300	\$0	\$0	\$4,300
<b>Santa Ysabel Pump Station</b>									
Pump No. 1	15		X		Unit Replacement	\$7,100	\$0	\$7,100	\$0
Pump No. 2	15			X	Unit Replacement	\$7,100	\$0	\$0	\$7,100
<b>Lupine Pump Station</b>									
Pump No. 1	15		X		Unit Replacement	\$19,000	\$0	\$19,000	\$0
Pump No. 2	15			X	Unit Replacement	\$19,000	\$0	\$0	\$19,000
Pump No. 3	15			X	Unit Replacement	\$19,000	\$0	\$0	\$19,000
<b>Solano Pump Station</b>									
Pump No. 1	15		X		Unit Replacement	\$19,000	\$0	\$19,000	\$0
Pump No. 2	15			X	Unit Replacement	\$19,000	\$0	\$0	\$19,000
<b>Mountain Viewm Pump Station</b>									
Pump No. 1	15		X		Unit Replacement	\$4,300	\$0	\$4,300	\$0
Pump No. 2	15			X	Unit Replacement	\$4,300	\$0	\$0	\$4,300
<b>Sunny Oaks Pump Station</b>									
Pump No. 1	15		X		Unit Replacement	\$4,300	\$0	\$4,300	\$0
Pump No. 2	15			X	Unit Replacement	\$4,300	\$0	\$0	\$4,300
<b>Mid Town Pump Station</b>									
Pump No. 1	15		X		Unit Replacement	\$50,000	\$0	\$50,000	\$0
Pump No. 2	15		X		Unit Replacement	\$50,000	\$0	\$50,000	\$0
Pump No. 3	15			X	Unit Replacement	\$50,000	\$0	\$0	\$50,000
Pump No. 4	15			X	Unit Replacement	\$50,000	\$0	\$0	\$50,000
Pump No. 5	15			X	Unit Replacement	\$50,000	\$0	\$0	\$50,000
Mag Meter	15			X	Unit Replacement	\$6,000	\$0	\$0	\$6,000
<b>Headworks</b>									
Influent Pump Station Influent Pump No. 1	15		X		Unit Replacement	\$19,000	\$0	\$19,000	\$0

Facility/Components	Overall Life Span	Service Age			Type of Service Required	Equipment Cost	Total	Total	Total
		5	10	15					
Influent Pump No. 2	15		X		Unit Replacement	\$19,000	\$0	\$19,000	\$0
Influent Pump No. 3	15			X	Unit Replacement	\$19,000	\$0	\$0	\$19,000
Influent Pump No. 4	15			X	Unit Replacement	\$19,000	\$0	\$0	\$19,000
Influent Screening									
Mechanical Bar Screen	10		X		Unit Replacement	\$138,000	\$0	\$138,000	\$0
Screenings Washer/Compactor	10		X		Unit Replacement	\$62,000	\$0	\$62,000	\$0
Odor Control									
Headworks Supply Fan	15			X	Motor Replacement/ Major Mechanical Refurbishment	\$9,000	\$0	\$0	\$3,600
Headworks Exhaust Fan	15			X	Unit Replacement	\$9,000	\$0	\$0	\$9,000
Septage Receiving									
Septage Receiving Tank	30								
Septage Transfer Pump	15			X	Unit Replacement	\$16,000	\$0	\$0	\$16,000
<b>Oxidation Ditch No. 1</b>									
Anoxic Mixer No. 1	20								
Anoxic Mixer No. 2	20								
Aerator No. 1	20		X		Minor Mechanical Refurbishment	\$121,000	\$0	\$18,150	\$0
Aerator No. 2	20			X	Minor Mechanical Refurbishment	\$121,000	\$0	\$0	\$18,150
<b>Oxidation Ditch No. 2</b>									
Anoxic Mixer No. 1	20								
Anoxic Mixer No. 2	20								
Aerator No. 1	20		X		Minor Mechanical Refurbishment	\$121,000	\$0	\$18,150	\$0
Aerator No. 2	20			X	Minor Mechanical Refurbishment	\$121,000	\$0	\$0	\$18,150



Facility/Components	Overall Life Span	Service Age			Type of Service Required	Equipment Cost	Total	Total	Total
		5	10	15					
<b>Secondary Clarifier No. 1</b>									
Clarifier Mechanism	20								
Scum Pump	15		X		Unit Replacement	\$8,000	\$0	\$8,000	\$0
<b>Secondary Clarifier No. 2</b>									
Clarifier Mechanism	20								
Scum Pump	15			X	Unit Replacement	\$8,000	\$0	\$0	\$8,000
<b>RAS/WAS Pump Station</b>									
RAS/WAS Pump No. 1	15		X		Motor Replacement/ Major Mechanical Refurbishment	\$30,000	\$0	\$12,000	\$0
RAS/WAS Pump No. 2	15			X	Unit Replacement	\$30,000	\$0	\$0	\$30,000
RAS/WAS Pump No. 3	15			X	Unit Replacement	\$30,000	\$0	\$0	\$30,000
RAS Mag Meter	15			X	Unit Replacement	\$6,000	\$0	\$0	\$6,000
WAS Mag Meter	15			X	Unit Replacement	\$4,000	\$0	\$0	\$4,000
<b>Solid Handling Facilities</b>									
Sludge Holding Tank	30								
Sludge Feed Pumps No. 1 (Progressive Cavity)	25		X		Motor Replacement/ Major Mechanical Refurbishment	\$40,000	\$0	\$16,000	\$0
Sludge Feed Pumps No.2 (Progressive Cavity)	25			X	Motor Replacement/ Major Mechanical Refurbishment	\$40,000	\$0	\$0	\$16,000
Belt Filter Press, Centrifuge or Screw Press	20						\$0	\$0	\$0
Polymer Feed Unit	15			X	Unit Replacement	\$31,000	\$0	\$0	\$31,000
Solids Conveyor No. 1	20								
Solids Conveyor No. 2	20								

Facility/Components	Overall Life Span	Service Age			Type of Service Required	Equipment Cost	Total	Total	Total
		5	10	15					
Odor Control									
Solids Building Supply Fan	15			X	Motor Replacement/ Major Mechanical Refurbishment	\$9,000	\$0	\$0	\$3,600
Solids Building Exhaust Fan	15			X	Unit Replacement	\$9,000	\$0	\$0	\$9,000
<b>Tertiary Filtration</b>									
Disk Filter Unit No. 1	5	X			Unit Replacement	\$8,000	\$8,000	\$0	\$0
Disk Filter Unit No. 2	5	X			Unit Replacement	\$8,000	\$8,000	\$0	\$0
<b>Disinfection</b>									
NaOCl Storage Tank	30								
NaOCl Feed Pump No. 1	10		X		Unit Replacement	\$12,000	\$0	\$12,000	\$0
NaOCl Feed Pump No. 2	10		X		Unit Replacement	\$12,000	\$0	\$12,000	\$0
UV Bank No. 1	5	X			Unit Replacement	\$163,320	\$163,320	\$0	\$0
UV Bank No. 2	5	X			Unit Replacement	\$163,320	\$163,320	\$0	\$0
UV Bank No. 3	5	X			Unit Replacement	\$163,320	\$163,320	\$0	\$0
<b>Effluent Pump Station</b>									
Effluent Pump No. 1	25		X		Motor Replacement/ Major Mechanical Refurbishment	\$80,000	\$0	\$32,000	\$0
Effluent Pump No. 2	25			X	Motor Replacement/ Major Mechanical Refurbishment	\$80,000	\$0	\$0	\$32,000
Effluent Pump No. 3	25			X	Motor Replacement/ Major Mechanical Refurbishment	\$80,000	\$0	\$0	\$32,000
Plant Water Pump No. 1	25		X		Motor Replacement/ Major Mechanical Refurbishment	\$21,000	\$0	\$8,400	\$0

Facility/Components	Overall Life Span	Service Age			Type of Service Required	Equipment Cost	Total	Total	Total
		5	10	15					
Plant Water Pump No. 2	25			X	Motor Replacement/ Major Mechanical Refurbishment	\$21,000	\$0	\$0	\$8,400
<b>Potable/Fire Water Storage</b>									
Water Storage Tank	30								
Fire Pump (Engine Driven)	20								
<b>Storm Water Pump Station</b>									
Storm Water Pump No. 1	20								
Storm Water Pump No. 2	20			X	Unit Replacement	\$15,000	\$0	\$0	\$15,000
<b>Totals</b>									
Total Cost per Replacment Period							<b>\$506,000</b>	<b>\$603,000</b>	<b>\$672,000</b>
Annual Cost per Replacement Period							<b>\$101,200</b>	<b>\$60,300</b>	<b>\$44,800</b>
<b>Total Annual Short-Lived Assets Reserve Fund Allocation</b>									<b>\$206,300</b>

**Operation and Maintenance Costs (With Project)**

Since operation of the wastewater project will continue beyond the project life cycle, operation and maintenance costs continue throughout the project lifecycle. As previously described, based on guidance provided by DWR, estimated operation and maintenance costs are reported in 2009 dollars and do not include assumed inflation during the project life cycle.

Operation and maintenance costs for the wastewater project were developed for the USDA’s Preliminary Engineer’s Report. Estimated operation and maintenance for the gravity collection system, treatment plant, biosolids and recycled water reuse are summarized in the tables below. A summary of all project O&M costs is also included.

**Estimated Annual Wastewater Project Collection System Operation and Maintenance Costs**

Estimated Annual O&M Costs for Gravity Collection System				
Item	Units	Quantity	Unit Price (\$)	Annual O&M (\$)
Labor	Hrs/year	4,160 <sup>(1)</sup>	40 <sup>(2)</sup>	170,000
Power	Kwh/year	500,000 <sup>(3)</sup>	0.12 <sup>(2)</sup>	60,000
Equipment Maintenance				200,000
<b>TOTAL O&amp;M COST<sup>(4)</sup></b>				<b>\$430,000</b>
(1) Based on 2 full-time employees and 2,080 hours per year. (2) From Basis of Cost Evaluation Technical Memorandum. (3) Based on energy required to convey 1.4 mgd to an out-of-town treatment facility. (4) Septic hauling costs for homes outside of the Prohibition Zone are not included.				

Annual O&M costs for each of the treatment alternatives were estimated for the following categories based on BioTran<sup>®</sup> modeling of unit process requirements.

- Labor
- Power
- Maintenance/ Equipment Replacement
- Allowances—Includes chemicals, screenings and grit disposal
- Unit cost curves for tertiary treatment per MGD

**Estimated Annual Wastewater Project Treatment Process Operation and Maintenance Costs**

Estimated Annual O&M Costs for Treatment Process				
Item	Units	Quantity	Unit Price (\$)	Annual O&M (\$)
Labor	Hrs/year	5,200	60 <sup>(1)</sup>	310,000
Power	Kwh/year	900,000	0.12 <sup>(2)</sup>	110,000
Equipment Maintenance				75,000
Allowances				50,000
Tertiary Filter O&M				100,000
<b>TOTAL O&amp;M COST</b>				<b>\$645,000</b>
(1) Labor costs are based on an average \$60 hourly rate, including direct and indirect costs. (2) Power costs based on \$0.12 per kWh electrical rate.				

The cost basis for biosolids processing was developed in the Fine Screening Report and is based on master planning efforts for a similar sized facility in Morro Bay, CA.

**Estimated Annual Wastewater Project Biosolids Processing Operation and Maintenance Costs**

Estimated Annual O&M Costs for Biosolids Processing	
Item	Annual O&M (\$)
Thickening <sup>(1)</sup>	170,000
Mechanical Dewatering <sup>(1)</sup>	280,000
Hauling <sup>(2) (3)</sup>	190,000
<b>TOTAL O&amp;M COST</b>	<b>\$640,000</b>
<p>(1) Includes labor, power, chemicals, and maintenance.                      (2) Based on an average solids volume from primary and secondary treatment process of 4,000 pounds per day (dry weight) with dewatering to 18% solids.                      (3) Based on a hauling and tipping fee at San Joaquin Composting facility of \$42 per ton for Class B biosolids and \$46 per ton for Sub-Class B biosolids.</p>	

The cost basis for recycled water reuse was developed in the Fine Screening Report, Appendix A, and is based on estimated energy costs for delivering recycled water to reuse locations and labor costs for routine maintenance.

**Estimated Annual Wastewater Project Recycled Water Operation and Maintenance Costs**

Estimated Annual O&M Costs for Recycled Water Reuse				
Item	Units	Quantity	Unit Price (\$)	Annual O&M (\$)
Leachfield Labor	Hrs/year	1,500	60 <sup>(1)</sup>	90,000
Leachfield Power	Kwh/year	1,375,000	0.12 <sup>(2)</sup>	165,000
Reuse Irrigation Power	Kwh/year	333,000	0.12 <sup>(2)</sup>	40,000
<b>TOTAL O&amp;M COST</b>				<b>\$295,000</b>
<p>Notes:                      (1) Labor costs are based on an average \$60 hourly rate, including direct and indirect costs.                      (2) Power costs based on \$0.12 per kWh electrical rate.                      (3) Cost estimates summarized from Table A2 of Fine Screening Report (Carollo, August, 2007)</p>				

**Estimated Annual Wastewater Project Total Operation and Maintenance Costs**

<b>Summary of Total Project Annual O&amp;M Cost Estimate</b>	
	<b>Annual O&amp;M</b>
Collection System	
• Labor	\$170,000
• Power	\$60,000
• Equipment Maintenance	\$200,000
Treatment Process	
• Labor	\$310,000
• Power	\$110,000
• Equipment Maintenance	\$75,000
• Allowances	\$50,000
• Tertiary Filter O&M	\$100,000
Solids Handling	
• Thickening & Dewatering	\$450,000
• Hauling	\$190,000
Recycled Water Reuse	
• Leachfield Energy	\$165,000
• Leachfield Labor	\$90,000
• Reuse Irrigation Energy	\$40,000
Miscellaneous Costs	
• Habitat Mitigation	\$10,000
• County Overhead and Billing	\$300,000
• Contingency/Operating Reserves	\$50,000
<b>Total Annual O&amp;M Costs</b>	<b>\$2,370,000</b>

***Operation and Maintenance Costs (Without Project)***

For each project alternative, operation costs that are dependent on the amount of supplemental water delivered each year (dollars per acre-foot basis) of the project lifecycle are projected. Operation and maintenance costs for the alternative supply projects are based on the Imported Water Tech Memo and field experience from a Los Osos Water purveyor. Operation and maintenance costs are estimated to be \$1,180/Acre Foot for State Water and is incorporated into the contract and part of the \$600/Acre Foot for well head treatment.

***Water Supply Costs (With Project)***

There are no additional water supply costs associated with the Los Osos Community Wastewater Project. Tertiary treatment and 100% beneficial reuse of the treated effluent are part of the total wastewater project.

***Water Supply Costs (Without Project)***

There are no water supply costs associated with well head treatment. The cost to buy-in to existing State Water infrastructure was estimated in the Imported Water Technical Memorandum from \$15,000 to \$20,000 per acre-ft, which results in a conservative total of \$18 million.

### *Total Project Cost (With Project)*

The total project cost are reported in Table 7-2 (PSP Table 11) of this economic analysis are consistent with costs reported in Attachment 4, and do not include sunk costs or costs spent in the past that have no recoverable value. Costs are expressed in 2009 dollars and are discounted according to the discount rates identified in the Proposition 84 PSP.

### **Avoided Cost Benefits**

As previously described, the Los Osos Wastewater Project is a mandated project by the Regional Water Control Board. Alternative means of providing supplemental water were evaluated, but the wastewater project should provide the water supply necessary to balance the basin. Even with other alternatives available, the County has identified the wastewater project as being the most cost effective approach to improving the community's water supply

Since an alternative supplemental water project would need to be implemented if the wastewater project were not executed, this economic analysis considers benefits of the wastewater project in terms of avoided costs relative to the "without-project condition," which would involve implementation of the next most feasible project alternative with comparable objectives and benefits. The total present value of discounted avoided costs is **\$65,337,940**, as presented in Table 7-3 (PSP Table 13).

Table 7-2: Annual Cost of Los Osos Wastewater Community Project (2 pages)

Annual Cost of Project									
Project: Los Osos Community Wastewater Project									
Initial Costs		Operations and Maintenance Costs <sup>(1)</sup>					Discounting Calculations		
YEAR	(a) Grand Total Cost From Table 7 (row (i), column(d))	(b) Admin	(c) Operation	(d) Maintenance	(e) Replacement	(f) Other	(g) Total Costs (a) +...+ (f)	(h) Discount Factor	(i) Discounted Costs(g) x (h)
2009	\$160,350,000						\$160,350,000	1.000	\$160,350,000
2010							\$0	0.943	\$0
2011							\$0	0.890	\$0
2012							\$0	0.840	\$0
2013							\$0	0.792	\$0
2014		\$300,000	\$1,585,000	\$425,000	\$206,300	\$60,000	\$2,576,300	0.747	\$1,924,496
2015		\$300,000	\$1,585,000	\$425,000	\$206,300	\$60,000	\$2,576,300	0.705	\$1,816,292
2016		\$300,000	\$1,585,000	\$425,000	\$206,300	\$60,000	\$2,576,300	0.665	\$1,713,240
2017		\$300,000	\$1,585,000	\$425,000	\$206,300	\$60,000	\$2,576,300	0.627	\$1,615,340
2018		\$300,000	\$1,585,000	\$425,000	\$206,300	\$60,000	\$2,576,300	0.592	\$1,525,170
2019		\$300,000	\$1,585,000	\$425,000	\$206,300	\$60,000	\$2,576,300	0.558	\$1,437,575
2020		\$300,000	\$1,585,000	\$425,000	\$206,300	\$60,000	\$2,576,300	0.527	\$1,357,710
2021		\$300,000	\$1,585,000	\$425,000	\$206,300	\$60,000	\$2,576,300	0.497	\$1,280,421
2022		\$300,000	\$1,585,000	\$425,000	\$206,300	\$60,000	\$2,576,300	0.469	\$1,208,285
2023		\$300,000	\$1,585,000	\$425,000	\$206,300	\$60,000	\$2,576,300	0.442	\$1,138,725
2024		\$300,000	\$1,585,000	\$425,000	\$206,300	\$60,000	\$2,576,300	0.417	\$1,074,317
2025		\$300,000	\$1,585,000	\$425,000	\$206,300	\$60,000	\$2,576,300	0.394	\$1,015,062
2026		\$300,000	\$1,585,000	\$425,000	\$206,300	\$60,000	\$2,576,300	0.371	\$955,807
2027		\$300,000	\$1,585,000	\$425,000	\$206,300	\$60,000	\$2,576,300	0.350	\$901,705
2028		\$300,000	\$1,585,000	\$425,000	\$206,300	\$60,000	\$2,576,300	0.331	\$852,755
2029		\$300,000	\$1,585,000	\$425,000	\$206,300	\$60,000	\$2,576,300	0.312	\$803,806
2030		\$300,000	\$1,585,000	\$425,000	\$206,300	\$60,000	\$2,576,300	0.294	\$757,432
2031		\$300,000	\$1,585,000	\$425,000	\$206,300	\$60,000	\$2,576,300	0.278	\$716,211
2032		\$300,000	\$1,585,000	\$425,000	\$206,300	\$60,000	\$2,576,300	0.262	\$674,991
2033		\$300,000	\$1,585,000	\$425,000	\$206,300	\$60,000	\$2,576,300	0.247	\$636,346
2034		\$300,000	\$1,585,000	\$425,000	\$206,300	\$60,000	\$2,576,300	0.233	\$600,278



Annual Cost of Project									
Project: Los Osos Community Wastewater Project									
Initial Costs		Operations and Maintenance Costs <sup>(1)</sup>					Discounting Calculations		
YEAR	(a) Grand Total Cost From Table 7 (row (i), column(d))	(b) Admin	(c) Operation	(d) Maintenance	(e) Replacement	(f) Other	(g) Total Costs (a) +...+ (f)	(h) Discount Factor	(i) Discounted Costs(g) x (h)
2035		\$300,000	\$1,585,000	\$425,000	\$206,300	\$60,000	\$2,576,300	0.220	\$566,786
2036		\$300,000	\$1,585,000	\$425,000	\$206,300	\$60,000	\$2,576,300	0.207	\$533,294
2037		\$300,000	\$1,585,000	\$425,000	\$206,300	\$60,000	\$2,576,300	0.196	\$504,955
2038		\$300,000	\$1,585,000	\$425,000	\$206,300	\$60,000	\$2,576,300	0.185	\$476,616
2039		\$300,000	\$1,585,000	\$425,000	\$206,300	\$60,000	\$2,576,300	0.174	\$448,276
2040		\$300,000	\$1,585,000	\$425,000	\$206,300	\$60,000	\$2,576,300	0.164	\$422,513
2041		\$300,000	\$1,585,000	\$425,000	\$206,300	\$60,000	\$2,576,300	0.155	\$399,327
2042		\$300,000	\$1,585,000	\$425,000	\$206,300	\$60,000	\$2,576,300	0.146	\$376,140
2043		\$300,000	\$1,585,000	\$425,000	\$206,300	\$60,000	\$2,576,300	0.138	\$355,529
2044		\$300,000	\$1,585,000	\$425,000	\$206,300	\$60,000	\$2,576,300	0.130	\$334,919
2045		\$300,000	\$1,585,000	\$425,000	\$206,300	\$60,000	\$2,576,300	0.123	\$316,885
2046		\$300,000	\$1,585,000	\$425,000	\$206,300	\$60,000	\$2,576,300	0.116	\$298,851
2047		\$300,000	\$1,585,000	\$425,000	\$206,300	\$60,000	\$2,576,300	0.109	\$280,817
2048		\$300,000	\$1,585,000	\$425,000	\$206,300	\$60,000	\$2,576,300	0.103	\$265,359
2049		\$300,000	\$1,585,000	\$425,000	\$206,300	\$60,000	\$2,576,300	0.097	\$249,901
2050		\$300,000	\$1,585,000	\$425,000	\$206,300	\$60,000	\$2,576,300	0.092	\$237,020
2051		\$300,000	\$1,585,000	\$425,000	\$206,300	\$60,000	\$2,576,300	0.087	\$224,138
2052		\$300,000	\$1,585,000	\$425,000	\$206,300	\$60,000	\$2,576,300	0.082	\$211,257
2053		\$300,000	\$1,585,000	\$425,000	\$206,300	\$60,000	\$2,576,300	0.077	\$198,375
2054		\$300,000	\$1,585,000	\$425,000	\$206,300	\$60,000	\$2,576,300	0.073	\$188,070
2055		\$300,000	\$1,585,000	\$425,000	\$206,300	\$60,000	\$2,576,300	0.069	\$177,765
2056		\$300,000	\$1,585,000	\$425,000	\$206,300	\$60,000	\$2,576,300	0.065	\$167,460
2057		\$300,000	\$1,585,000	\$425,000	\$206,300	\$60,000	\$2,576,300	0.061	\$157,154
2058		\$300,000	\$1,585,000	\$425,000	\$206,300	\$60,000	\$2,576,300	0.058	\$149,425
Total Present Value of Discounted Costs (Sum of Column (i))									\$191,896,794
Transfer to Table 20, column (c), Exhibit F: Proposal Costs and Benefits Summaries									

Table 7-3: Annual Costs of Avoided Projects (2 pages)

Annual Costs of Avoided Projects											
Project: Los Osos Community Wastewater Project											
Costs					Costs				Discounting Calculations		
(a)	(b)	(c)	(d)	(e)	(b)	(c)	(d)	(e)		(f)	(g)
YEAR	Alternative (Avoided Project Name): Pump & Treat Nitrate Contamination				Alternative (Avoided Project Name): Imported State Water to Stop Sea Water Intrusion				Total Costs Avoided All Alternatives (Sum of Total Cost Avoided for Individual Alternatives)	Disco unt Factor	Discounted Costs (e) x (f)
	Avoided Capital Costs	Avoided Replacement Costs	Avoided Operations and Maintenance Costs	Total Cost Avoided for Individual Alternatives (b) + (c) + (d)	Avoided Capital Costs	Avoided Replacement Costs	Avoided Operations and Maintenance Costs	Total Cost Avoided for Individual Alternatives			
2009	\$4,700,000	\$141,000	\$540,000	\$5,381,000	\$20,300,000	\$609,000	\$ 1,124,000	\$22,033,000	\$27,414,000	1.000	\$27,414,000
2010		\$141,000	\$540,000	\$681,000		\$609,000	\$ 1,124,000	\$1,733,000	\$2,414,000	0.943	\$2,276,402
2011		\$141,000	\$540,000	\$681,000		\$609,000	\$ 1,124,000	\$1,733,000	\$2,414,000	0.890	\$2,148,460
2012		\$141,000	\$540,000	\$681,000		\$609,000	\$ 1,124,000	\$1,733,000	\$2,414,000	0.840	\$2,027,760
2013		\$141,000	\$540,000	\$681,000		\$609,000	\$ 1,124,000	\$1,733,000	\$2,414,000	0.792	\$1,911,888
2014		\$141,000	\$540,000	\$681,000		\$609,000	\$ 1,124,000	\$1,733,000	\$2,414,000	0.747	\$1,803,258
2015		\$141,000	\$540,000	\$681,000		\$609,000	\$ 1,124,000	\$1,733,000	\$2,414,000	0.705	\$1,701,870
2016		\$141,000	\$540,000	\$681,000		\$609,000	\$ 1,124,000	\$1,733,000	\$2,414,000	0.665	\$1,605,310
2017		\$141,000	\$540,000	\$681,000		\$609,000	\$ 1,124,000	\$1,733,000	\$2,414,000	0.627	\$1,513,578
2018		\$141,000	\$540,000	\$681,000		\$609,000	\$ 1,124,000	\$1,733,000	\$2,414,000	0.592	\$1,429,088
2019		\$141,000	\$540,000	\$681,000		\$609,000	\$ 1,124,000	\$1,733,000	\$2,414,000	0.558	\$1,347,012
2020		\$141,000	\$540,000	\$681,000		\$609,000	\$ 1,124,000	\$1,733,000	\$2,414,000	0.527	\$1,272,178
2021		\$141,000	\$540,000	\$681,000		\$609,000	\$ 1,124,000	\$1,733,000	\$2,414,000	0.497	\$1,199,758
2022		\$141,000	\$540,000	\$681,000		\$609,000	\$ 1,124,000	\$1,733,000	\$2,414,000	0.469	\$1,132,166
2023		\$141,000	\$540,000	\$681,000		\$609,000	\$ 1,124,000	\$1,733,000	\$2,414,000	0.442	\$1,066,988
2024		\$141,000	\$540,000	\$681,000		\$609,000	\$ 1,124,000	\$1,733,000	\$2,414,000	0.417	\$1,006,638
2025		\$141,000	\$540,000	\$681,000		\$609,000	\$ 1,124,000	\$1,733,000	\$2,414,000	0.394	\$951,116
2026		\$141,000	\$540,000	\$681,000		\$609,000	\$ 1,124,000	\$1,733,000	\$2,414,000	0.371	\$895,594
2027		\$141,000	\$540,000	\$681,000		\$609,000	\$ 1,124,000	\$1,733,000	\$2,414,000	0.350	\$844,900
2028		\$141,000	\$540,000	\$681,000		\$609,000	\$ 1,124,000	\$1,733,000	\$2,414,000	0.331	\$799,034

2029		\$141,000	\$540,000	\$681,000		\$609,000	\$ 1,124,000	\$1,733,000	\$2,414,000	0.312	\$753,168
2030		\$141,000	\$540,000	\$681,000		\$609,000	\$ 1,124,000	\$1,733,000	\$2,414,000	0.294	\$709,716
2031		\$141,000	\$540,000	\$681,000		\$609,000	\$ 1,124,000	\$1,733,000	\$2,414,000	0.278	\$671,092
2032		\$141,000	\$540,000	\$681,000		\$609,000	\$ 1,124,000	\$1,733,000	\$2,414,000	0.262	\$632,468
2033		\$141,000	\$540,000	\$681,000		\$609,000	\$ 1,124,000	\$1,733,000	\$2,414,000	0.247	\$596,258
2034		\$141,000	\$540,000	\$681,000		\$609,000	\$ 1,124,000	\$1,733,000	\$2,414,000	0.233	\$562,462
2035		\$141,000	\$540,000	\$681,000		\$609,000	\$ 1,124,000	\$1,733,000	\$2,414,000	0.220	\$531,080
2036		\$141,000	\$540,000	\$681,000		\$609,000	\$ 1,124,000	\$1,733,000	\$2,414,000	0.207	\$499,698
2037		\$141,000	\$540,000	\$681,000		\$609,000	\$ 1,124,000	\$1,733,000	\$2,414,000	0.196	\$473,144
2038		\$141,000	\$540,000	\$681,000		\$609,000	\$ 1,124,000	\$1,733,000	\$2,414,000	0.185	\$446,590
2039		\$141,000	\$540,000	\$681,000		\$609,000	\$ 1,124,000	\$1,733,000	\$2,414,000	0.174	\$420,036
2040		\$141,000	\$540,000	\$681,000		\$609,000	\$ 1,124,000	\$1,733,000	\$2,414,000	0.164	\$395,896
2041		\$141,000	\$540,000	\$681,000		\$609,000	\$ 1,124,000	\$1,733,000	\$2,414,000	0.155	\$374,170
2042		\$141,000	\$540,000	\$681,000		\$609,000	\$ 1,124,000	\$1,733,000	\$2,414,000	0.146	\$352,444
2043		\$141,000	\$540,000	\$681,000		\$609,000	\$ 1,124,000	\$1,733,000	\$2,414,000	0.138	\$333,132
2044		\$141,000	\$540,000	\$681,000		\$609,000	\$ 1,124,000	\$1,733,000	\$2,414,000	0.130	\$313,820
2045		\$141,000	\$540,000	\$681,000		\$609,000	\$ 1,124,000	\$1,733,000	\$2,414,000	0.123	\$296,922
2046		\$141,000	\$540,000	\$681,000		\$609,000	\$ 1,124,000	\$1,733,000	\$2,414,000	0.116	\$280,024
2047		\$141,000	\$540,000	\$681,000		\$609,000	\$ 1,124,000	\$1,733,000	\$2,414,000	0.109	\$263,126
2048		\$141,000	\$540,000	\$681,000		\$609,000	\$ 1,124,000	\$1,733,000	\$2,414,000	0.103	\$248,642
2049		\$141,000	\$540,000	\$681,000		\$609,000	\$ 1,124,000	\$1,733,000	\$2,414,000	0.097	\$234,158
2050		\$141,000	\$540,000	\$681,000		\$609,000	\$ 1,124,000	\$1,733,000	\$2,414,000	0.092	\$222,088
2051		\$141,000	\$540,000	\$681,000		\$609,000	\$ 1,124,000	\$1,733,000	\$2,414,000	0.087	\$210,018
2052		\$141,000	\$540,000	\$681,000		\$609,000	\$ 1,124,000	\$1,733,000	\$2,414,000	0.082	\$197,948
2053		\$141,000	\$540,000	\$681,000		\$609,000	\$ 1,124,000	\$1,733,000	\$2,414,000	0.077	\$185,878
2054		\$141,000	\$540,000	\$681,000		\$609,000	\$ 1,124,000	\$1,733,000	\$2,414,000	0.073	\$176,222
2055		\$141,000	\$540,000	\$681,000		\$609,000	\$ 1,124,000	\$1,733,000	\$2,414,000	0.069	\$166,566
2056		\$141,000	\$540,000	\$681,000		\$609,000	\$ 1,124,000	\$1,733,000	\$2,414,000	0.065	\$156,910
2057		\$141,000	\$540,000	\$681,000		\$609,000	\$ 1,124,000	\$1,733,000	\$2,414,000	0.061	\$147,254
2058		\$141,000	\$540,000	\$681,000		\$609,000	\$ 1,124,000	\$1,733,000	\$2,414,000	0.058	\$140,012
<b>Total Present Value of Discounted Costs (Sum of Column (g))</b>											\$65,337,940
<b>(%) Avoided Cost Claimed by Project</b>											100%
<b>Total Present Value of Discounted Avoided Project Costs Claimed by alternative Project (Total Present Value of Discounted Costs x % Avoided Cost Claimed by Project)</b>											\$65,337,940

## Other Benefits

The wastewater project will provide immediate benefit to the local community. In addition to satisfying the legal requirements of the Central Coast Regional Water Quality Control Board, the project will improve water quality and increase water supply. Regional benefits include the availability of supplemental water to other communities, since Los Osos will not be using State Water or Nacimiento water. Statewide benefits include the increased protection of valuable marine resources. The table below highlights the benefits distributed to each category.

<b>Los Osos Project Beneficiaries</b>		
Local	Regional	Statewide
The community of Los Osos will satisfy a Regional Water Board mandate, improve groundwater quality, and address seawater intrusion	Supplemental water sources will remain available to other communities	Protection of environmental resources within the Morro Bay State Marine Reserve

## Total Water Supply Benefits

The total water supply benefit is simply the total present value of discounted avoided project costs from Table 7-3.

<b>Table 7 -4: Total Water Supply Benefits</b>			
<b>Project: Los Osos Wastewater Project</b>			
Total Discounted Water Supply Benefits (a)	Total Discounted Avoided Project Costs (b)	Other Discounted Water Supply Benefits (c)	Total Present Value of Discounted Benefits (d) (a) + (c) or (b) + (c)
\$0	\$65,337,940	\$0	\$65,337,940

## Beneficiaries

The wastewater project will benefit groundwater users in the community of Los Osos, including municipal users, private residential users, and agricultural users. Decreased urban demand, beneficial reuse of treated wastewater, improved water quality, and decreased potential for seawater intrusion will allow private residential users of groundwater and agricultural users in Los Osos to continue to utilize groundwater as a municipal and agriculture supply of water.

## Realization and Certainty of Benefits

The project's useful life is expected to be 50 years, with construction of the wastewater facility ending – and the community connected to a wastewater system – in 2014. Customers connected directly to the system will realize the benefits of wastewater treatment at project start up and those benefits will continue through operation of the facility. Benefits to groundwater users will be immediate due to reduced demand on the groundwater basin from water conservation. Additionally, groundwater users will see increasing benefits as treated effluent is used as a beneficial resource to replenish the groundwater basin.

## Uncertainty of the Benefits (With Project)

The analysis provided is based on historical studies and assumptions made by independent consultants who are professionals in their respective fields. However, some uncertainty in the calculation of benefit still exists.

- Reduction of nitrate concentrations in the upper groundwater basin and restoration of its beneficial use: The reduction of nitrates introduced into the aquifer should begin once septic discharges cease. The rate of restoration of the groundwater basin to a beneficial use is estimated as approximately 30 years and based on water quality modeling. The modeling has numerous parameters that each have a level of uncertainty; therefore, the timing for restoration of the basin is less certain. Groundwater monitoring in accordance with the plan presented in Attachment 6 will monitor and measure the performance of the project and the project operation may have to be adjusted through adaptive management practices
- Elimination of existing seawater intrusion and establishment of a sustainable water supply: Undeveloped parcels are still subject to certain conditions before obtaining a building permit. However, it is still believed elimination of seawater intrusion and a sustainable water supply can be achieved because the project incorporates 100% beneficial reuse of the treated effluent.

## Uncertainty of the Benefits (Without Project)

- Well Head Nitrate Removal: The increased use of septic tanks (assuming no wastewater treatment plant, may result in an increase in nitrate levels. Treatment at the well head may become difficult or impossible. Costs would also increase.
- State Water: State Water deliveries may be less than 100% during the projected project timeline. The inability to obtain the necessary water would have an impact on provided the assumed benefits.

## Adverse Effects

Adverse effects from the wastewater project will consist of temporary construction disturbances that typically occur from collection system and treatment facility construction. Permit conditions requiring adaptive monitoring and management of biological resources will further prevent the project from having adverse effects.

## Nipomo Waterline Intertie Project (Project Number 4) Introduction and Approach

The following water supply economic analysis for the Nipomo Waterline Intertie Project has been developed according to the requirements and guidance outlined in the Proposition 84 Proposal Solicitation Package (PSP) and the Guidelines document provided by the Department of Water Resources Division of Integrated Regional Water Management, and using available studies, reports, and technical documents. Components of the Waterline Intertie Project are described in further detail in Attachment 3 of the Proposal.

The following documents are referenced in this water supply economic analysis and provided electronically:

- Evaluation of Supplemental Water Alternatives Technical Memorandum No. 1, Constraints Analysis (Boyle Engineering, 2007)
- Evaluation of Desalination as a Source of Supplemental Water Technical Memorandum No. 2 (Boyle Engineering, 2007)
- Evaluation of Supplemental Water Alternatives Technical Memorandum No. 3, Implementation of Water Supply from CCWA/ State Water Pipeline (Boyle Engineering, 2007)
- 2010 Nipomo Community Services District Strategic Plan Update (NCSO, 2010)
- Finalized Wholesale Water Supply Agreement (approved by the NCSO and the City of Santa Maria January 2010)
- Waterline Intertie Project Design Phase Status Report (AECOM, November, 2010)

The Nipomo Waterline Intertie Project responds to the Santa Maria Groundwater Basin adjudication and the stipulation for developing a supplemental water supply. Without the Project, an alternative project would need to be implemented. Alternative means of providing supplemental water were evaluated in the Evaluation of Supplemental Water Alternatives (Technical Memorandums 1 through 3, Boyle Engineering, 2007). This evaluation identified the Waterline Intertie Project as being the most cost effective approach to providing supplemental water, and desalination was identified as the next most feasible alternative. Desalination was also identified as the District's long-term approach for meeting future water demands (2010 NCSO Strategic Plan Update). Since an alternative supplemental water project would need to be implemented if the Waterline Intertie Project were not executed, the "without-project condition" involves implementation of an alternative project meeting comparable objectives. Therefore, benefits of the Waterline Intertie Project are considered in this economic analysis in terms of avoided costs, relative to implementation of the next most feasible alternative supplemental water project, and using Table 13 for qualifying avoided project costs. Since desalination has been identified as both the second most feasible supplemental water project and the District's long-term water supply strategy, the "without-project" condition is defined as construction of a desalination facility with a capacity and delivery schedule similar to the Waterline Intertie Project. Costs associated with the Desalination supplemental water supply alternative are documented in the Evaluation of Desalination as a Source of Supplemental Water (Technical Memorandum 2, Boyle Engineering, 2007).

*Desalination has been identified as the second most feasible alternative and will be the basis for the 'without-Nipomo Waterline Intertie Project' condition.*

The Nipomo Waterline Intertie Project as currently designed will provide a total of 3,000 AFY of supplemental water to the Nipomo Mesa Management Area. The project will provide 2,500 AFY of supplemental water pursuant to the stipulation and an additional 500 AFY of supplemental water to serve future development within the existing NCSO boundaries in accordance with the County of San Luis Obispo South County Area Plan (General Plan), September 2006. Both the Waterline Intertie Project and the alternative desalination project considered in this economic analysis would be capable of providing 3,000 AFY and satisfying legal requirements for a supplemental water supply. Additionally, the fixed water demands (3,000 AFY) satisfied by either project will continue beyond each project's lifecycle.

## Economic Costs

Costs considered in this economic analysis include initial implementation costs and estimated on-going costs associated with the administration, operation, and maintenance of the Waterline Intertie Project, and replacement of project components. Similarly, both initial investments and on-going costs associated with the “without-project” alternative (Desalination) that would be needed to accomplish full implementation of the project and achieve benefits identified in this analysis are considered. As outlined in the Proposition 84 guideline documents, costs reported in Table 7-5 (Guidelines Table 11) of this economic analysis are consistent with costs reported in Attachment 4 (Guidelines Table 7), and do not include sunk costs or costs spent in the past that have no recoverable value. Costs and benefits presented in Tables 7-5, 7-6, and 7-7 are expressed in 2009 dollars and are discounted according to the discount rates identified in the Proposition 84 PSP. Based on discussion with DWR’s representative, costs for financing the construction of projects should not be considered in this economic analysis and should be excluded from the economic analysis tables. Also, based on DWR’s guidance, costs reported for project administration, operation, maintenance, and replacement are reported in 2009 dollars and do not include assumed inflation during the project life cycle. A narrative description and associated cost details for the following project factors for with and without project conditions are included in this Attachment:

- Period of Economic Analysis
- Initial Project Costs
- Replacement Costs
- Operation & Maintenance Costs
- Water Supply Costs

### *Period of Economic Analysis (With and Without Project)*

The economic analysis for the Waterline Intertie Project and the ‘without-project’ alternative (Desalination) is based on a project life cycle of 75 years. This project life cycle coincides with the terms of the final Wholesale Water Supply Agreement approved by the NCSD and the City of Santa Maria (January 2010). This project life cycle also exceeds the projected operational life of the majority of the Waterline Interline Project components and the reverse osmosis membranes and other components of the Desalination facility. Projected operational life of project components are summarized in the Replacement Costs section, below.

### *Initial Project Costs (With Project)*

Initial project costs for the Waterline Intertie Project included in this economic analysis are based on the current Engineer’s Opinion of Probable Construction Cost (90-percent design cost opinion) included in the Waterline Intertie Project Design Phase Status Report (AECOM, November 2010), and information on incurred costs provided by NCSD. Costs associated with the Waterline Intertie Project are summarized in Attachment 4. Since the Waterline Intertie Project is currently at 90-percent design, and much of the required planning, design, and environmental documentation has been completed, these and other costs have been estimated and excluded from Table 7-5 costs, in accordance with the table below. Also, funds expended to date have been used for studies, preliminary design, environmental documentation, development of construction documents, and administration of the project, and no assets which would retain future value if the project was not implemented have been acquired. Therefore, no opportunity costs are included. Contingencies are also excluded from Table 7-5. Remaining initial costs associated with implementation of the Waterline Intertie Project are distributed in Table 7-5 over the projected construction period (2011 through 2012).

**Nipomo Waterline Intertie Project Sunk and Future Project Costs**

Budget Category	Cost Schedule		
	9/30/08 – 9/30/10	Future	Total
Direct Project Administration	\$154,421	\$292,612	\$447,033
Land Purchase/Easement	\$49,308	\$275,821	\$325,129
Planning/Design/Engineering/EIR	\$1,299,925	\$368,346	\$1,668,271
Construction	\$0	\$15,878,200	\$15,878,200
Environmental Compliance	\$0	\$160,000	\$160,000
Construction Administration	\$0	\$2,666,274	\$2,666,274
Other Costs	\$0	\$0	\$0
Construction Contingency	\$0	\$2,946,000	\$2,946,000
<b>Grand Total</b>	<b>\$1,503,654</b>	<b>\$22,587,253</b>	<b>\$24,090,907</b>

1. Cost schedule based on Waterline Intertie Project Design Phase Status Report (AECOM, November 2010) and additional information on expended costs, provided by NCSA.
2. Total cost is consistent with Attachment 7, Project Budget.
3. Future cost, minus construction contingency, is distributed in Table 7-5 over projected construction period (contingencies are excluded).

***Initial Project Costs (Without Project)***

Capital costs for the alternative water supply project (Desalination) are based on the conceptual cost estimate for construction of a desalination facility capable of delivering 3,000 AFY of water, presented in the Evaluation of Desalination as a Source of Supplemental Water Technical Memorandum 2 (Boyle Engineering, September 2007). Since this alternative project would have been implemented in the fall of 2007 (when the District made the decision to pursue the Waterline Intertie Project), projected economic costs for the Desalination project are presented in Table 7-6 according to the preliminary schedule identified for the desalination project in the Evaluation of Desalination as a Source of Supplemental Water (Boyle Engineering, 2007). Costs associated with studies, planning, engineering and permitting would have begun in the fourth quarter of 2007 and, as projected in the desalination project schedule, ended in the first quarter of 2015. Total costs associated with these tasks are summarized in the table below. The sum of these costs has been evenly distributed according to the desalination project schedule. Annual distributed costs are also summarized in the table below. By consistently distributing projected costs for the alternative project similarly to the occurrence of costs associated with implementation of the Waterline Intertie Project over the past three years, this method of distribution allows a reasonable comparison of costs associated with the two supplemental water alternatives. As previously described, based on guidance provided by DWR, costs for financing projects should not be considered in this economic analysis and are not included in Tables 7-5 and 7-6.



**Projected Distribution of Initial Costs for Desalination Project Alternative**

Phase 1 Desalination Project Implementation	Probable Costs (a)		Distribution Period, years (c)	Annual Distributed Cost (d)		
	(2007)	(2009)				
<b>Planning, Studies, and Design</b>						
Terrestrial and Freshwater Impact Studies	\$440,000	\$457,600	7.5	\$1,282,000		
Phase 1 Marine Impact Studies	\$250,000	\$260,000				
Cultural Resource Study	\$66,000	\$68,640				
Phase 1 Hydrogeologic Field Study	\$360,000	\$374,400				
Test-Scale Feasibility Study	\$2,320,000	\$2,412,800				
Phase 2 Hydrogeologic Field Study	\$180,000	\$187,200				
Preliminary Engineering	\$210,000	\$218,400				
CEQA/NEPA	\$240,000	\$249,600				
Public Outreach	\$1,310,000	\$1,362,400				
Design and Permitting	\$3,870,000	\$4,024,800				
<b>Subtotal</b>	<b>\$9,246,000</b>	<b>\$9,615,840</b>				
Contingency (b)	\$2,272,000	\$2,362,880				
<b>Total Planning Studies and Design</b>	<b>\$11,518,000</b>	<b>\$11,979,000</b>				
<b>Construction</b>						
Construction (Phase 1, 3,000 AFY)	\$58,200,000	\$60,528,000	1.0	\$62,088,000		
Project Management	\$1,500,000	\$1,560,000				
<b>Subtotal</b>	<b>\$59,700,000</b>	<b>\$62,088,000</b>				
Contingency (b)	\$14,668,000	\$15,254,720				
<b>Total Construction Phase</b>	<b>\$74,368,000</b>	<b>\$77,343,000</b>				
<b>Desalination Project Total Probable Cost</b>	<b>\$85,890,000</b>	<b>\$89,322,000</b>				

(a) Probable cost data based on Desalination Phase 1 (3,000 AFY) costs reported in the 2007 Evaluation of Desalination as a Source of Supplemental Water. Costs updated to 2009 dollars per DWR IRWM Prop 84 PSP Table 10 Update Factors, using a factor of 1.04 for 2007 dollars. Totals rounded to 1,000.

(b) Contingency used in the 2007 Evaluation of Desalination separated between overall Planning, Studies, and Design and Construction Phases.

(c) General distribution of project costs based on preliminary desalination project schedule.

(d) Total costs for planning studies, and design distributed evenly from Q4 2007 through Q1 2015. Total costs for construction phase distributed evenly from Q1 2015 through Q1 2016. Annual distributed costs do not include contingencies and are presented in 2009 dollars.

**Replacement Costs (With Project)**

It is assumed that the water demand satisfied by either of the projects will continue beyond the project life cycle, therefore, total replacement costs for each project include estimated replacement costs for all components of the project needed to continue operation through the identified period of analysis and beyond. Based on guidance provided by DWR, estimated replacement costs are reported in 2009 dollars and do not include assumed inflation during the project life cycle.

Costs associated with replacement of project components are accounted for as “replacement costs.” For the Waterline Intertie Project, replacement costs are grouped by major project components and are based on initial construction costs. Replacement costs are distributed evenly over the estimated design life of each component. For

example, a project component with an initial construction cost of \$50,000 in 2009 dollars and an estimated design life of 10 years would result in an annual distribution of estimated replacement cost for that component of \$5,000 (2009 dollars) for each year of the overall project's design life (75 years in this case). In this way, projected replacement costs are budgeted annually instead of once over the duration of the component's design life. Construction costs for major and minor project components of the Waterline Intertie Project and estimated design lives and replacement schedules are summarized on page 33.

### *Replacement Costs (Without Project)*

For the desalination project, replacement costs have been estimated as a combination of costs associated with reverse osmosis membranes and other general replacement costs, estimated as 1% of the project capital cost, annually. Membrane replacement costs are estimated using data reported by the Bureau of Reclamation (Desalination and Water Purification Research and Development Program Report No. 72, 2003) for desalination of seawater using reverse osmosis membrane technology. Membrane replacement costs are considered on a per acre-foot basis in 2009 dollars, according to the delivery schedule identified in the final Wholesale Water Supply Agreement approved by the NCSD and the City of Santa Maria (2010). Estimated annual replacement costs for the desalination project are presented on page 34.

### *Operation and Maintenance Costs (With Project)*

Since the water demand satisfied by either of the projects will continue beyond the project life cycle, operation and maintenance costs continue throughout the project lifecycle. As previously described, based on guidance provided by DWR, estimated operation and maintenance costs are reported in 2009 dollars and do not include assumed inflation during the project life cycle.

Operation and maintenance costs for the Waterline Intertie Project have been developed based on available design information, estimated cost of consumables such as chloramination reagents, electricity, etc., and estimated staffing cost for operation of facilities, and a maintenance budget to account for routine operator tasks and materials used for preventative maintenance. Estimated operation and maintenance costs are summarized at the end of page 34.

**Estimated Annual Replacement Cost for Waterline Intertie Project**

Item	Component	Capital Cost	Estimated Component Life (Years)	Est. Annual Replacement Cost
1	Prestressed concrete reservoir (partially buried 500,000 gal.)	\$1,432,800	100	\$14,328
2	(4) 200-hp Vertical Turbine Pumps (2,000 gpm capacity)	\$340,000	20	\$17,000
3	Ductile Iron, Steel, and PVC Piping (various sizes)	\$7,112,020	75	\$94,827
4	Pump Station CMU Building (1300 FT <sup>2</sup> )	\$443,000	75	\$5,907
5	Chloramination Facilities (5 sites)	\$563,300	10	\$56,330
6	Horizontal Direction Drilled 24-inch HDPE Pipe (2700 LF)	\$4,828,000	100	\$48,280
7	Control Valves (10 PRVs and 1 FCV)	\$72,152	20	\$3,608
8	Project Electrical	\$279,500	20	\$13,975
9	Project Controls (VFDs, SCADA connection )	\$158,500	15	\$10,567
10	Other	\$648,928	20	\$32,446
	<b>Total</b>	<b>\$15,878,200</b>	<b>n/a</b>	<b>\$298,000</b>

- a. Capital costs are based on 90% design engineer's opinion of probable construction cost and exclude contingency. All costs are reported in 2009 dollars. Total estimated Annual Replacement Costs rounded to 000.
- b. Line Item 1 includes cost for partially buried tank and appurtenances, excavation and structural backfill.
- c. Line Item 2 includes cost for replacement/rebuilding of pumps and cans only.
- d. Line Item 3 includes costs to replace all project piping, valves (except control valves), and appurtenances, with trenching, traffic control, sheeting and shoring and asphalt repair.
- e. Line Item 4 includes cost to replace 1300 square foot CMU building and related site grading.
- f. Line Item 5 includes cost to replace chloramination facilities including chemical tanks, dosing equipment, and analyzers.
- g. Line Item 6 includes costs to replace approximately 2700-linear feet of 24-inch HDPE pipe across the Santa Maria River via HDPE and approximately 250-LF of deep 24-inch DIP between the levee jack-and-bore and HDPE entry.
- h. Line Item 7 includes costs to replace five 6-inch pressure reducing valves (PRVs), five 2 ½-inch PRV, and one 16-inch flow control valve (FCV).
- i. Line Item 8 includes costs to replace all electrical components on the project, including 300-KW standby generator and fuel tank, pump station lighting, and wiring of components.
- j. Line Item 9 includes costs to replace controls components on the project including four VFDs for the 200-hP pumps, SCADA connections for the pump station, the chloramination facilities, control valves, and meters.
- k. Line Item 10 includes other project replacement costs, calculated by subtracting costs for lines 1 through 9 from the total project capital cost. Components covered here include pump station/tank site landscaping and irrigation, access road to pump station/tank site, valve vaults, hatches, and ladders, sump pumps in the control valve and meter vaults, etc.

**Estimated Annual Replacement Cost for Desalination Project**

Operation Years	Scheduled Delivery, AFY (a)	Estimated Membrane Replacement Cost (b)		Probable Capital Cost (c)	General Annual Replacement Costs (d)	Est. Annual Replacement Costs
		\$/ AF	\$/ year			
Years 1 through 10	2,000	\$46	\$92,320	\$60,528,000	\$605,280	\$697,600
Years 11 through 19	2,500		\$115,400			\$720,680
Year 20 through end of term	3,000		\$138,480			\$743,760

- a. Delivery schedule based on the final Wholesale Water Supply Agreement approved by the NCSO and the City of Santa Maria (2010).
- b. Membrane replacement cost based on data reported by the Bureau of Reclamation (2003) for desalination of seawater using reverse osmosis membrane technology (2003), presented in dollars/ AF of product water, and adjusted to 2009 dollars.
- c. Probable cost data based on Desalination Phase 1 (3,000 AFY) construction cost reported in the 2007 Evaluation of Desalination as a Source of Supplemental Water. Costs updated to 2009 dollars per DWR IRWM Proposition 84 PSP Table 10 Update Factors, using a factor of 1.04 for costs considered in 2007 dollars.
- d. General annual replacement costs assume 1% replacement of direct capital costs on an annual basis.

**Estimated Annual Waterline Intertie Project Operation and Maintenance Costs**

Operation Years	Scheduled Delivery, AFY (a)	Operation Costs (b)		Est. Annual Operator and Maintenance Cost (c)	Total Annual O&M Costs
		\$/ AF	\$/ year		
Years 1 through 10	2,000	\$60	\$120,000	\$119,000	\$239,000
Years 11 through 19	2,500		\$150,000		\$269,000
Year 20 through end of term	3,000		\$180,000		\$299,000

- a. Delivery schedule based on the final Wholesale Water Supply Agreement approved by the NCSO and the City of Santa Maria (January, 2010)
- b. Projected operations costs include energy usage, consumable chemicals for chloramination and residual disinfection, and do not include water supply cost, which are accounted for in the Water Supply Costs section below.
- c. Estimated annual maintenance based on one full-time equivalent operator salary and estimated maintenance materials budget.

**Operation and Maintenance Costs (Without Project)**

For each project alternative, operation costs that are dependent on the amount of supplemental water delivered each year (dollars per acre-foot basis) of the project lifecycle are projected using the delivery schedule outlined in the final Wholesale Water Supply Agreement approved by the NCSO and the City of Santa Maria (January, 2010). Annual operation and maintenance costs for the desalination project are distributed evenly between columns “c” and “d” of Table 7-6 for respective delivery years.

Operation and maintenance costs for the alternative supply project (desalination) are based on the preliminary operation and maintenance cost estimates presented in the Evaluation of Desalination as a Source of Supplemental

Water Technical Memorandum 2 (Boyle Engineering, September, 2007) for a desalination facility capable of delivering 3,000 AFY of water. Operation and maintenance costs are provided in the table below.

**Estimated Annual Desalination Project Operation and Maintenance Costs**

Operation Years	Scheduled Delivery, AFY (a)	Estimated Operation & Maintenance Costs (b)	
		\$/ AF	\$/ year
Years 1 through 10	2,000	\$1,100	\$2,660,000
Years 11 through 19	2,500		\$3,325,000
Year 20 through end of term	3,000		\$3,990,000

- a. Delivery schedule based on the final Wholesale Water Supply Agreement approved by the NCSD and the City of Santa Maria (January 2010) and is assumed for the desalination project, for consistency.
- b. Operation and maintenance costs based on the O&M costs in the Evaluation of Desalination as a Source of Supplemental Water Technical Memorandum 2 (Boyle Engineering, September 2007).
- c. Estimated annual maintenance based on one full-time equivalent operator salary and estimated maintenance materials budget.

**Water Supply Costs (With Project)**

Water supply costs for the Waterline Intertie Project are based on the final Wholesale Water Supply Agreement approved by the NCS D and the City of Santa Maria (January 2010). Annual water supply costs for the Waterline Intertie Project are calculated using the fixed cost per unit of water (\$1270.22 per AF) and the annual delivery schedule outlined in the final Wholesale Water Supply Agreement (2010). Annual water supply costs are reported in Column “F” of Table 7-5. As previously described, based on guidance provided by DWR, estimated economic costs are reported in 2009 dollars and do not include assumed inflation during the project life cycle.

**Annual Water Supply Costs**

Operation Years	Scheduled Delivery, AFY	Annual Water Supply Costs	
		\$/ AF	\$/ year
Years 1 through 10	2,000	\$1,270	\$2,540,000
Years 11 through 19	2,500		\$3,175,000
Year 20 through end of term	3,000		\$3,810,000

- a. Delivery schedule and unit cost for water based on the final Wholesale Water Supply Agreement approved by the NCS D and the City of Santa Maria (January 2010).

**Water Supply Costs (Without Project)**

There are no water supply costs associated with the alternative water supply project (desalination).

**Total Project Cost (With Project)**

The total present value of the discounted project costs is **\$67,275,671** as reported in Table 7-5 (Guidelines Table 11). This calculation is consistent with costs reported in Attachment 4 (Guidelines Table 7), and do not include sunk costs or costs spent in the past that have no recoverable value. Costs are expressed in 2009 dollars and are discounted according to the discount rates identified in the Proposition 84 PSP.

**Avoided Cost Benefits**

As previously described, the Waterline Intertie Project responds to adjudication of the Santa Maria Groundwater Basin and the court stipulation for a supplemental water supply. Alternative means of providing supplemental water were evaluated in the Evaluation of Supplemental Water Alternatives (Technical Memorandums 1 through 3, Boyle Engineering, 2007). Through this evaluation, the District identified the Waterline Intertie Project as being the most cost effective approach to providing supplemental water. Desalination was identified as the next most feasible alternative and was also identified as the District’s long-term supplement water supply approach for meeting future water demands in the 2010 NCS D Strategic Plan Update.

Since an alternative supplemental water project would need to be implemented if the Waterline Intertie Project were not executed, this economic analysis considers benefits of the Waterline Intertie Project in terms of avoided costs relative to the “without-project condition,” which would involve implementation of the next most feasible project alternative with comparable objectives and benefits. The total present value of discounted avoided costs is **\$97,966,302**, as presented in Table 7-6 (Guidelines Table 13). These costs and are based on available documentation and published literature, as described above.

Both the Waterline Intertie Project and the alternative desalination project considered in this economic analysis would be capable of providing 3,000 AFY and satisfying legal requirements for a supplemental water supply. Additionally, the fixed water demands (3,000 AFY) satisfied by either project will continue beyond each project’s lifecycle.

Table 7-5: Annual Cost of Project (All costs are in 2009 dollars) Project: Nipomo Waterline Intertie Project									
Initial Costs		Operations and Maintenance Costs <sup>(1)</sup>					Discounting Calculations		
YEAR	(a) Grand Total Cost From Table 7 (row (i), column(d))	(b) Admin	(c) Operation	(d) Maintenance	(e) Replacement	(f) Other	(g) Total Costs (a) +...+ (f)	(h) Discount Factor	(i) Discounted Costs(g) x (h)
2009							\$0	1.000	\$0
2010							\$0	0.943	\$0
2011	\$9,820,627						\$9,820,627	0.890	\$8,740,358
2012	\$9,820,627						\$9,820,627	0.840	\$8,249,326
2013			\$120,000	\$119,000	\$298,000	\$2,540,000	\$3,077,000	0.792	\$2,436,984
2014			\$120,000	\$119,000	\$298,000	\$2,540,000	\$3,077,000	0.747	\$2,298,519
2015			\$120,000	\$119,000	\$298,000	\$2,540,000	\$3,077,000	0.705	\$2,169,285
2016			\$120,000	\$119,000	\$298,000	\$2,540,000	\$3,077,000	0.665	\$2,046,205
2017			\$120,000	\$119,000	\$298,000	\$2,540,000	\$3,077,000	0.627	\$1,929,279
2018			\$120,000	\$119,000	\$298,000	\$2,540,000	\$3,077,000	0.592	\$1,821,584
2019			\$120,000	\$119,000	\$298,000	\$2,540,000	\$3,077,000	0.558	\$1,716,966
2020			\$120,000	\$119,000	\$298,000	\$2,540,000	\$3,077,000	0.527	\$1,621,579
2021			\$120,000	\$119,000	\$298,000	\$2,540,000	\$3,077,000	0.497	\$1,529,269
2022			\$120,000	\$119,000	\$298,000	\$2,540,000	\$3,077,000	0.469	\$1,443,113
2023			\$150,000	\$119,000	\$298,000	\$3,175,000	\$3,742,000	0.442	\$1,653,964
2024			\$150,000	\$119,000	\$298,000	\$3,175,000	\$3,742,000	0.417	\$1,560,414
2025			\$150,000	\$119,000	\$298,000	\$3,175,000	\$3,742,000	0.394	\$1,474,348
2026			\$150,000	\$119,000	\$298,000	\$3,175,000	\$3,742,000	0.371	\$1,388,282
2027			\$150,000	\$119,000	\$298,000	\$3,175,000	\$3,742,000	0.350	\$1,309,700
2028			\$150,000	\$119,000	\$298,000	\$3,175,000	\$3,742,000	0.331	\$1,238,602
2029			\$150,000	\$119,000	\$298,000	\$3,175,000	\$3,742,000	0.312	\$1,167,504
2030			\$150,000	\$119,000	\$298,000	\$3,175,000	\$3,742,000	0.294	\$1,100,148
2031			\$150,000	\$119,000	\$298,000	\$3,175,000	\$3,742,000	0.278	\$1,040,276
2032			\$150,000	\$119,000	\$298,000	\$3,175,000	\$3,742,000	0.262	\$980,404

**Table 7-5: Annual Cost of Project**  
(All costs are in 2009 dollars)  
Project: Nipomo Waterline Intertie Project

YEAR	Initial Costs		Operations and Maintenance Costs <sup>(1)</sup>				Discounting Calculations		
	(a) Grand Total Cost From Table 7 (row (i), column(d))	(b) Admin	(c) Operation	(d) Maintenance	(e) Replacement	(f) Other	(g) Total Costs (a) +...+ (f)	(h) Discount Factor	(i) Discounted Costs(g) x (h)
2033			\$180,000	\$119,000	\$298,000	\$3,810,000	\$4,407,000	0.247	\$1,088,529
2034			\$180,000	\$119,000	\$298,000	\$3,810,000	\$4,407,000	0.233	\$1,026,831
2035			\$180,000	\$119,000	\$298,000	\$3,810,000	\$4,407,000	0.220	\$969,540
2036			\$180,000	\$119,000	\$298,000	\$3,810,000	\$4,407,000	0.207	\$912,249
2037			\$180,000	\$119,000	\$298,000	\$3,810,000	\$4,407,000	0.196	\$863,772
2038			\$180,000	\$119,000	\$298,000	\$3,810,000	\$4,407,000	0.185	\$815,295
2039			\$180,000	\$119,000	\$298,000	\$3,810,000	\$4,407,000	0.174	\$766,818
2040			\$180,000	\$119,000	\$298,000	\$3,810,000	\$4,407,000	0.164	\$722,748
2041			\$180,000	\$119,000	\$298,000	\$3,810,000	\$4,407,000	0.155	\$683,085
2042			\$180,000	\$119,000	\$298,000	\$3,810,000	\$4,407,000	0.146	\$643,422
2043			\$180,000	\$119,000	\$298,000	\$3,810,000	\$4,407,000	0.138	\$608,166
2044			\$180,000	\$119,000	\$298,000	\$3,810,000	\$4,407,000	0.130	\$572,910
2045			\$180,000	\$119,000	\$298,000	\$3,810,000	\$4,407,000	0.123	\$542,061
2046			\$180,000	\$119,000	\$298,000	\$3,810,000	\$4,407,000	0.116	\$511,212
2047			\$180,000	\$119,000	\$298,000	\$3,810,000	\$4,407,000	0.109	\$480,363
2048			\$180,000	\$119,000	\$298,000	\$3,810,000	\$4,407,000	0.103	\$453,921
2049			\$180,000	\$119,000	\$298,000	\$3,810,000	\$4,407,000	0.097	\$427,479
2050			\$180,000	\$119,000	\$298,000	\$3,810,000	\$4,407,000	0.092	\$405,444
2051			\$180,000	\$119,000	\$298,000	\$3,810,000	\$4,407,000	0.087	\$383,409
2052			\$180,000	\$119,000	\$298,000	\$3,810,000	\$4,407,000	0.082	\$361,374
2053			\$180,000	\$119,000	\$298,000	\$3,810,000	\$4,407,000	0.077	\$339,339
2054			\$180,000	\$119,000	\$298,000	\$3,810,000	\$4,407,000	0.073	\$321,711
2055			\$180,000	\$119,000	\$298,000	\$3,810,000	\$4,407,000	0.069	\$304,083
2056			\$180,000	\$119,000	\$298,000	\$3,810,000	\$4,407,000	0.065	\$286,455



**Table 7-5: Annual Cost of Project**  
(All costs are in 2009 dollars)  
Project: Nipomo Waterline Intertie Project

YEAR	Initial Costs		Operations and Maintenance Costs <sup>(1)</sup>				Discounting Calculations		
	(a) Grand Total Cost From Table 7 (row (i), column(d))	(b) Admin	(c) Operation	(d) Maintenance	(e) Replacement	(f) Other	(g) Total Costs (a) +...+ (f)	(h) Discount Factor	(i) Discounted Costs(g) x (h)
2057			\$180,000	\$119,000	\$298,000	\$3,810,000	\$4,407,000	0.061	\$268,827
2058			\$180,000	\$119,000	\$298,000	\$3,810,000	\$4,407,000	0.058	\$255,606
2059			\$180,000	\$119,000	\$298,000	\$3,810,000	\$4,407,000	0.054	\$237,978
2060			\$180,000	\$119,000	\$298,000	\$3,810,000	\$4,407,000	0.051	\$224,757
2061			\$180,000	\$119,000	\$298,000	\$3,810,000	\$4,407,000	0.048	\$211,536
2062			\$180,000	\$119,000	\$298,000	\$3,810,000	\$4,407,000	0.046	\$202,722
2063			\$180,000	\$119,000	\$298,000	\$3,810,000	\$4,407,000	0.043	\$189,501
2064			\$180,000	\$119,000	\$298,000	\$3,810,000	\$4,407,000	0.041	\$180,687
2065			\$180,000	\$119,000	\$298,000	\$3,810,000	\$4,407,000	0.038	\$167,466
2066			\$180,000	\$119,000	\$298,000	\$3,810,000	\$4,407,000	0.036	\$158,652
2067			\$180,000	\$119,000	\$298,000	\$3,810,000	\$4,407,000	0.034	\$149,838
2068			\$180,000	\$119,000	\$298,000	\$3,810,000	\$4,407,000	0.032	\$141,024
2069			\$180,000	\$119,000	\$298,000	\$3,810,000	\$4,407,000	0.030	\$132,210
2070			\$180,000	\$119,000	\$298,000	\$3,810,000	\$4,407,000	0.029	\$127,803
2071			\$180,000	\$119,000	\$298,000	\$3,810,000	\$4,407,000	0.027	\$118,989
2072			\$180,000	\$119,000	\$298,000	\$3,810,000	\$4,407,000	0.025	\$110,175
2073			\$180,000	\$119,000	\$298,000	\$3,810,000	\$4,407,000	0.024	\$105,768
2074			\$180,000	\$119,000	\$298,000	\$3,810,000	\$4,407,000	0.023	\$101,361
2075			\$180,000	\$119,000	\$298,000	\$3,810,000	\$4,407,000	0.021	\$92,547
2076			\$180,000	\$119,000	\$298,000	\$3,810,000	\$4,407,000	0.02	\$88,140
2077			\$180,000	\$119,000	\$298,000	\$3,810,000	\$4,407,000	0.019	\$83,733
2078			\$180,000	\$119,000	\$298,000	\$3,810,000	\$4,407,000	0.018	\$79,326
2079			\$180,000	\$119,000	\$298,000	\$3,810,000	\$4,407,000	0.017	\$74,919
2080			\$180,000	\$119,000	\$298,000	\$3,810,000	\$4,407,000	0.016	\$70,512

Table 7-5: Annual Cost of Project (All costs are in 2009 dollars) Project: Nipomo Waterline Intertie Project									
	Initial Costs		Operations and Maintenance Costs <sup>(1)</sup>				Discounting Calculations		
YEAR	(a) Grand Total Cost From Table 7 (row (i), column(d))	(b) Admin	(c) Operation	(d) Maintenance	(e) Replacement	(f) Other	(g) Total Costs (a) +...+ (f)	(h) Discount Factor	(i) Discounted Costs(g) x (h)
2081			\$180,000	\$119,000	\$298,000	\$3,810,000	\$4,407,000	0.015	\$66,105
2082			\$180,000	\$119,000	\$298,000	\$3,810,000	\$4,407,000	0.014	\$61,698
2083			\$180,000	\$119,000	\$298,000	\$3,810,000	\$4,407,000	0.013	\$57,291
2084			\$180,000	\$119,000	\$298,000	\$3,810,000	\$4,407,000	0.013	\$57,291
2085			\$180,000	\$119,000	\$298,000	\$3,810,000	\$4,407,000	0.012	\$52,884
Total Present Value of Discounted Costs (Sum of Column (i))									\$67,275,671
Transfer to Table 20, column (c), Exhibit F: Proposal Costs and Benefits Summaries									

(1) The incremental change in O&M costs attributable to the project.

<b>Table 7-6: Annual Costs of Avoided Project</b>						
<b>(All avoided costs are in 2009 dollars)</b>						
<b>Project: NCS D Waterline Intertie Project</b>						
<b>Costs</b>					<b>Discounting Calculations</b>	
<b>(a)</b>	<b>(b)</b>	<b>(c)</b>	<b>(d)</b>	<b>(e)</b>	<b>(f)</b>	<b>(g)</b>
<b>YEAR</b>	<b>Alternative : Phase 1 Desalination Project</b>				<b>Discount Factor</b>	<b>Discounted Costs (e) x (f)</b>
	<i>Avoided Project Description: Desalination facility for providing 3,000 AFY of supplemental water supply.</i>					
	<b>Avoided Capital Costs</b>	<b>Avoided Replacement Costs</b>	<b>Avoided Operations and Maintenance Costs</b>	<b>Total Cost Avoided for Individual Alternatives (b) + (c) + (d)</b>		
2007	\$641,000			\$641,000	1.040	\$666,640
2008	\$1,282,000			\$1,282,000	1.010	\$1,294,820
2009	\$1,282,000			\$1,282,000	1.000	\$1,282,000
2010	\$1,282,000			\$1,282,000	0.943	\$1,208,926
2011	\$1,282,000			\$1,282,000	0.890	\$1,140,980
2012	\$1,282,000			\$1,282,000	0.840	\$1,076,880
2013	\$1,282,000			\$1,282,000	0.792	\$1,015,344
2014	\$1,282,000			\$1,282,000	0.747	\$957,654
2015	\$62,088,000			\$62,088,000	0.705	\$43,772,040
2016		\$697,600	\$2,660,000	\$3,357,600	0.665	\$2,232,804
2017		\$697,600	\$2,660,000	\$3,357,600	0.627	\$2,105,215
2018		\$697,600	\$2,660,000	\$3,357,600	0.592	\$1,987,699
2019		\$697,600	\$2,660,000	\$3,357,600	0.558	\$1,873,541
2020		\$697,600	\$2,660,000	\$3,357,600	0.527	\$1,769,455
2021		\$697,600	\$2,660,000	\$3,357,600	0.497	\$1,668,727
2022		\$697,600	\$2,660,000	\$3,357,600	0.469	\$1,574,714
2023		\$697,600	\$2,660,000	\$3,357,600	0.442	\$1,484,059
2024		\$697,600	\$2,660,000	\$3,357,600	0.417	\$1,400,119
2025		\$697,600	\$2,660,000	\$3,357,600	0.394	\$1,322,894
2026		\$720,700	\$3,325,000	\$4,045,700	0.371	\$1,500,955
2027		\$720,700	\$3,325,000	\$4,045,700	0.350	\$1,415,995
2028		\$720,700	\$3,325,000	\$4,045,700	0.331	\$1,339,127
2029		\$720,700	\$3,325,000	\$4,045,700	0.312	\$1,262,258
2030		\$720,700	\$3,325,000	\$4,045,700	0.294	\$1,189,436
2031		\$720,700	\$3,325,000	\$4,045,700	0.278	\$1,124,705
2032		\$720,700	\$3,325,000	\$4,045,700	0.262	\$1,059,973
2033		\$720,700	\$3,325,000	\$4,045,700	0.247	\$999,288
2034		\$720,700	\$3,325,000	\$4,045,700	0.233	\$942,648
2035		\$720,700	\$3,325,000	\$4,045,700	0.220	\$890,054
2036		\$743,800	\$3,990,000	\$4,733,800	0.207	\$979,897
2037		\$743,800	\$3,990,000	\$4,733,800	0.196	\$927,825
2038		\$743,800	\$3,990,000	\$4,733,800	0.185	\$875,753

**Table 7-6: Annual Costs of Avoided Project**  
(All avoided costs are in 2009 dollars)  
Project: NCSO Waterline Intertie Project

Costs							Discounting Calculations	
(a)	(b)	(c)	(d)	(e)	(f)	(g)		
YEAR	Alternative : Phase 1 Desalination Project				Discount Factor	Discounted Costs (e) x (f)		
	Avoided Capital Costs	Avoided Replacement Costs	Avoided Operations and Maintenance Costs	Total Cost Avoided for Individual Alternatives				
	<i>Avoided Project Description: Desalination facility for providing 3,000 AFY of supplemental water supply.</i>				(b) + (c) + (d)			
2039		\$743,800	\$3,990,000	\$4,733,800	0.174	\$823,681		
2040		\$743,800	\$3,990,000	\$4,733,800	0.164	\$776,343		
2041		\$743,800	\$3,990,000	\$4,733,800	0.155	\$733,739		
2042		\$743,800	\$3,990,000	\$4,733,800	0.146	\$691,135		
2043		\$743,800	\$3,990,000	\$4,733,800	0.138	\$653,264		
2044		\$743,800	\$3,990,000	\$4,733,800	0.130	\$615,394		
2045		\$743,800	\$3,990,000	\$4,733,800	0.123	\$582,257		
2046		\$743,800	\$3,990,000	\$4,733,800	0.116	\$549,121		
2047		\$743,800	\$3,990,000	\$4,733,800	0.109	\$515,984		
2048		\$743,800	\$3,990,000	\$4,733,800	0.103	\$487,581		
2049		\$743,800	\$3,990,000	\$4,733,800	0.097	\$459,179		
2050		\$743,800	\$3,990,000	\$4,733,800	0.092	\$435,510		
2051		\$743,800	\$3,990,000	\$4,733,800	0.087	\$411,841		
2052		\$743,800	\$3,990,000	\$4,733,800	0.082	\$388,172		
2053		\$743,800	\$3,990,000	\$4,733,800	0.077	\$364,503		
2054		\$743,800	\$3,990,000	\$4,733,800	0.073	\$345,567		
2055		\$743,800	\$3,990,000	\$4,733,800	0.069	\$326,632		
2056		\$743,800	\$3,990,000	\$4,733,800	0.065	\$307,697		
2057		\$743,800	\$3,990,000	\$4,733,800	0.061	\$288,762		
2058		\$743,800	\$3,990,000	\$4,733,800	0.058	\$274,560		
2059		\$743,800	\$3,990,000	\$4,733,800	0.054	\$255,625		
2060		\$743,800	\$3,990,000	\$4,733,800	0.051	\$241,424		
2061		\$743,800	\$3,990,000	\$4,733,800	0.048	\$227,222		
2062		\$743,800	\$3,990,000	\$4,733,800	0.046	\$217,755		
2063		\$743,800	\$3,990,000	\$4,733,800	0.043	\$203,553		
2064		\$743,800	\$3,990,000	\$4,733,800	0.041	\$194,086		
2065		\$743,800	\$3,990,000	\$4,733,800	0.038	\$179,884		
2066		\$743,800	\$3,990,000	\$4,733,800	0.036	\$170,417		
2067		\$743,800	\$3,990,000	\$4,733,800	0.034	\$160,949		
2068		\$743,800	\$3,990,000	\$4,733,800	0.032	\$151,482		
2069		\$743,800	\$3,990,000	\$4,733,800	0.030	\$142,014		
2070		\$743,800	\$3,990,000	\$4,733,800	0.029	\$137,280		
2071		\$743,800	\$3,990,000	\$4,733,800	0.027	\$127,813		
2072		\$743,800	\$3,990,000	\$4,733,800	0.025	\$118,345		

Table 7-6: Annual Costs of Avoided Project						
(All avoided costs are in 2009 dollars)						
Project: NCSO Waterline Intertie Project						
Costs					Discounting Calculations	
(a)	(b)	(c)	(d)	(e)	(f)	(g)
YEAR	Alternative : Phase 1 Desalination Project				Discount Factor	Discounted Costs (e) x (f)
	Avoided Capital Costs	Avoided Replacement Costs	Avoided Operations and Maintenance Costs	Total Cost Avoided for Individual Alternatives  (b) + (c) + (d)		
	<i>Avoided Project Description: Desalination facility for providing 3,000 AFY of supplemental water supply.</i>					
2073		\$743,800	\$3,990,000	\$4,733,800	0.024	\$113,611
2074		\$743,800	\$3,990,000	\$4,733,800	0.023	\$108,877
2075		\$743,800	\$3,990,000	\$4,733,800	0.021	\$99,410
2076		\$743,800	\$3,990,000	\$4,733,800	0.020	\$94,676
2077		\$743,800	\$3,990,000	\$4,733,800	0.019	\$89,942
2078		\$743,800	\$3,990,000	\$4,733,800	0.018	\$85,208
2079		\$743,800	\$3,990,000	\$4,733,800	0.017	\$80,475
2080		\$743,800	\$3,990,000	\$4,733,800	0.016	\$75,741
2081		\$743,800	\$3,990,000	\$4,733,800	0.015	\$71,007
2082		\$743,800	\$3,990,000	\$4,733,800	0.014	\$66,273
2083		\$743,800	\$3,990,000	\$4,733,800	0.013	\$61,539
2084		\$743,800	\$3,990,000	\$4,733,800	0.013	\$61,539
2085		\$743,800	\$3,990,000	\$4,733,800	0.012	\$56,806
Total Present Value of Discounted Costs (Sum of Column (g))						\$97,966,302
(% Avoided Cost Claimed by Project)						100%
Total Present Value of Discounted Avoided Project Costs Claimed by alternative Project (Total Present Value of Discounted Costs x % Avoided Cost Claimed by Project)						\$97,966,302

## Other Benefits

In addition to benefits considered in terms of avoided cost (described above), the Waterline Intertie Project will decrease demand on the Nipomo Mesa Hydrologic Sub-Area resulting from urban uses and will reduce overall groundwater pumping. The imported water will also contribute return flow to the groundwater sub area. Reduced demand and return flow from imported water will contribute to balancing of the groundwater sub area and will reduce potential for seawater intrusion. Finally, return flow from the project will improve groundwater quality (since the supply has lower TDS than local groundwater currently used to satisfy the District’s demands and use of wells exhibiting high TDS will be significantly reduced or eliminated). Improvement to groundwater quality is described and quantified further in Attachment 8.

## Total Water Supply Benefits

The total water supply benefit is simply the total present value of discounted avoided project costs from Table 7-6.

<b>Table 7-7: Total Water Supply Benefits</b>			
Project: Waterline Intertie Project			
Total Discounted Water Supply Benefits (a)	Total Discounted Avoided Project Costs (b)	Other Discounted Water Supply Benefits (c)	Total Present Value of Discounted Benefits (d) (a) + (c) or (b) + (c)
\$0	\$97,966,302	\$0	\$97,966,302

## Beneficiaries

The Waterline Intertie Project will benefit groundwater users in the Nipomo Mesa region, including municipal users, private residential users, and agricultural users. Decreased urban demand, return flow from imported water, improved water quality from return flow, and decreased potential for seawater intrusion will allow private residential users of groundwater and agricultural users in the Nipomo Mesa region to continue to utilize groundwater as a municipal and agriculture supply of water. Municipal and agricultural water supply benefits have been identified in the Central Coast Water Quality Control Plan (Basin Plan, SWRCB). Additionally, the project will benefit NMMA member agencies by satisfying the requirements of adjudication of the Santa Maria Groundwater Basin and eliminate the need to implement a more costly alternative supplemental water supply project in the near future.

## Realization and Certainty of Benefits

Benefits from the project will be realized once the Waterline Intertie projected is constructed and in operation. The current schedule projects system start up in December 2012. Customers connected directly to the system will realize the benefits at project start up and those benefits continue through operation of the facility. Benefits to groundwater users will also be immediate due to reduced demand on the groundwater basin. Additionally, groundwater users will see increasing benefits as return flow from imported water recharges the groundwater basin.

The Nipomo Waterline Intertie Project is the cornerstone of the physical solution recognized by the court as establishing a legal and physical mean for ensuring the groundwater basins long-term sustainability. The project will be monitored through the existing court approved monitoring plan through the Nipomo Mesa Management Area Technical Group to ensure that the anticipated benefits are realized and certain.

## **Adverse Effects**

Adverse effects from the Waterline Intertie Project will consist of temporary construction disturbances typical of a transmission pipeline and booster station construction project.

# REFERENCES





San Luis Obispo County  
Los Osos Wastewater Project Development

**TECHNICAL MEMORANDUM**

**IMPORTED WATER**

**FINAL**  
July 2008



San Luis Obispo County  
Los Osos Wastewater Project Development

**TECHNICAL MEMORANDUM**

**IMPORTED WATER**

**TABLE OF CONTENTS**

	<b><u>Page No.</u></b>
1.0 PURPOSE .....	1
2.0 INTRODUCTION .....	1
3.0 QUANTITY OF WATER TO BE IMPORTED.....	1
4.0 POTENTIAL SOURCES.....	2
4.1 State Water Project Water .....	3
4.2 Nacimiento Water .....	11
5.0 SUMMARY .....	16

**LIST OF TABLES**

Table 1	Levels of Seawater Intrusion Mitigation (Project Benefits) .....	2
Table 2	State Water Cost Estimates .....	10
Table 3	Summary of Imported Water Costs .....	17

**LIST OF FIGURES**

Figure 1	Base Map .....	4
Figure 2	Coastal Branch, Phase I .....	5
Figure 3	Pipeline Route .....	7
Figure 4	SWP Delivery Reliability.....	9
Figure 5	Unit Map for Nacimiento Water Project.....	13
Figure 6	Pipeline Alignment .....	14

## **1.0 PURPOSE**

The purpose of this technical memorandum is to identify the challenges and opportunities of potential sources of water for the community of Los Osos from outside the groundwater basin.

The Viable Project Alternatives Fine Screening Analysis (prepared by the County's project team, August 2007) identified and developed options for wastewater treatment and disposal. While importing water from outside the basin is not a function of a community wastewater project, it remains an option for future consideration by the Los Osos community water purveyors for solving the current basin overdraft.

## **2.0 INTRODUCTION**

Los Osos is facing major water resources issues due to seawater intrusion into the groundwater basin. The community of Los Osos currently relies entirely on its underlying groundwater for water supply and seawater is intruding into the lower aquifer. Various options are being considered to remedy this seawater intrusion and overdraft problem. One potential solution is to introduce a new water source into the community.

The water potentially brought into Los Osos from outside the groundwater basin is termed "imported water." If imported water is brought into Los Osos, it would be used to meet the potable demand of Los Osos. By using imported water for the potable needs of the community, the amount of water needed to be pumped from the groundwater basin would be reduced, thus mitigating the seawater intrusion that is currently taking place. The mitigation benefits of the reduced pumping is dependent on the location of where that pumping is being replaced (e.g., the closer to the bay that pumping is reduced, the greater the seawater intrusion benefit).

## **3.0 QUANTITY OF WATER TO BE IMPORTED**

Since the purpose of importing water would be to introduce a new supply to mitigate seawater intrusion, the quantity of water to be imported is calculated based on the level of mitigation desired. Five levels of mitigating seawater intrusion were defined in the Fine Screening Analysis.

Table 1 describes the quantitative mitigation benefits of each of the levels.

<b>Table 1 Levels of Seawater Intrusion Mitigation (Project Benefits)<sup>(1)</sup> Los Osos Wastewater Project Development San Luis Obispo County</b>				
<b>Level</b>	<b>Absolute Volume Mitigated (AFY)<sup>(2)</sup></b>	<b>Project Impact, Relative to Current Conditions (AFY)</b>	<b>Overall Basin Balance (at Current Pumping Rates) (AFY)</b>	<b>Description</b>
Level 0	0	-90	-550	No mitigation of seawater intrusion
Level 1	90 to 140	0 to 50	-460 to -410	Mitigation of seawater intrusion similar to current conditions
Level 2	190 to 240	100 to 150	-360 to -310	Maximum mitigation of seawater intrusion possible without purveyor participation
Level 3	550 to 600	460 to 510	0 to 50	Achievement of a balanced basin at present water use rates
Level 4 <sup>(3)</sup>	780 to 830	690 to 740	230 to 280	Achievement of a balanced basin at buildout

Notes:  
(1) In addition to the benefits associated with complying with the WDR.  
(2) One acre-foot/year (AFY) is equal to 892 gallons per day (gpd).  
(3) Levels 3 and 4 are possible to achieve, but only with extensive infrastructure reconfiguration by the water purveyors.

Imported water can be used to mitigate sea water intrusion by reducing the amount of lower aquifer groundwater needed to meet the community water demand. Based on the groundwater model developed by Cleath and Associates, reducing pumping of lower aquifer groundwater on the West side of the basin has a maximum mitigation factor of 0.55. Achieving a balanced basin at current levels of water demand requires eliminating approximately 500-acre-feet per year (AFY) of sea water intrusion. Therefore, the amount of imported water needed to achieve a balanced basin, assuming no other changes, would be approximately 900 AFY (500 AFY divided by the mitigation factor 0.55).

Currently, the community’s water purveyors are considering other efforts that would reduce seawater intrusion. Those efforts could therefore reduce the estimated 900 AFY of imported water required. At the community’s build-out, however, (Level 4), water demand would increase. Consequently, final estimates of the need for imported water, if any, will be known only after the community’s water purveyors have completed further evaluation of their groundwater management options – including the options that they may choose to pursue regarding re-use of treated effluent from a community wastewater project.

#### **4.0 POTENTIAL SOURCES**

The potential sources of imported water for Los Osos are State Water Project water, and Nacimiento water.

There has been some discussion with reference to the Clark Valley Watershed also being a potential source of imported water. The Clark Valley watershed drains to Los Osos Creek, which flows into the groundwater basin near the Los Osos Valley Equine Farms (Gorby Site) at the south end of the Los Osos Creek valley. The watershed drainage area upstream of the groundwater basin limits is approximately 7 square miles. Golden State Water Company had expressed interest in developing a well field at the southernmost end of the creek valley, since it is relatively close to its Bayview Heights system. This well field, if feasible, would not be a source of imported water, but would tap unconsolidated sediments within the groundwater basin. However, since the water from this watershed presently flows into the Los Osos groundwater basin, it is not a source of “imported water” and is thus not discussed further in this memorandum.

#### **4.1 State Water Project Water**

The State Water Project (SWP) is the largest State-built water and power development and conveyance system in the United States. Consisting of 17 pumping plants, 8 hydroelectric power plants, 29 dams and reservoirs, and 675 miles of aqueducts and pipelines, the SWP conveys around 2.4 million AFY to its 29 long-term contractors, and several other agencies. Figure 1 shows the State Water Project conveyance system.

The State Water Project has various branches off the California aqueduct, and the branch that would potentially supply water to Los Osos is the Chorro Valley Pipeline of the Coastal Branch. The Coastal Branch of the SWP consists of water conveyance facilities built by the California Department of Water Resources (DWR) and regional distribution and treatment facilities constructed by the Central Coast Water Authority (CCWA). Figure 2 shows the Coastal Branch of the SWP.

Although Phase 1 of the Coastal Branch (indicated in Figure 2) was completed in 1968, Phase 2, which brings water to San Luis Obispo and Santa Barbara Counties, was only completed in 1997. Phase 2 includes the 43 mgd Polonio Pass Treatment Plant (PPTP), 143 miles of pipeline, and additional pumping and storage facilities.

While the Coastal Branch was built by both DWR and CCWA, only CCWA is responsible for operating and maintaining the PPTP and all downstream Coastal Branch facilities. Contractual issues associated with connecting to the State Water Project are discussed further in 4.1.6.

##### **4.1.1 Bringing State Water to Los Osos**

During the Environmental Impact Report preparation stage for Phase 2 of the Coastal Branch, inclusions and provisions were made for all potential future users of State water. A provision of 300 AFY was made by San Luis Obispo (SLO) County for Los Osos. However since none of the Los Osos water purveyors contracted for any State Water, it was never included in any initial contracts, and thus the Chorro Valley pipeline was not designed to accommodate its needs.



**Figure 1**  
**NAMES AND LOCATIONS OF**  
**PRIMARY WATER DELIVERY FACILITIES**  
**STATE WATER PROJECT**  
**LOS OSOS WASTEWATER PROJECT DEVELOPMENT**  
**SAN LUIS OBISPO COUNTY**

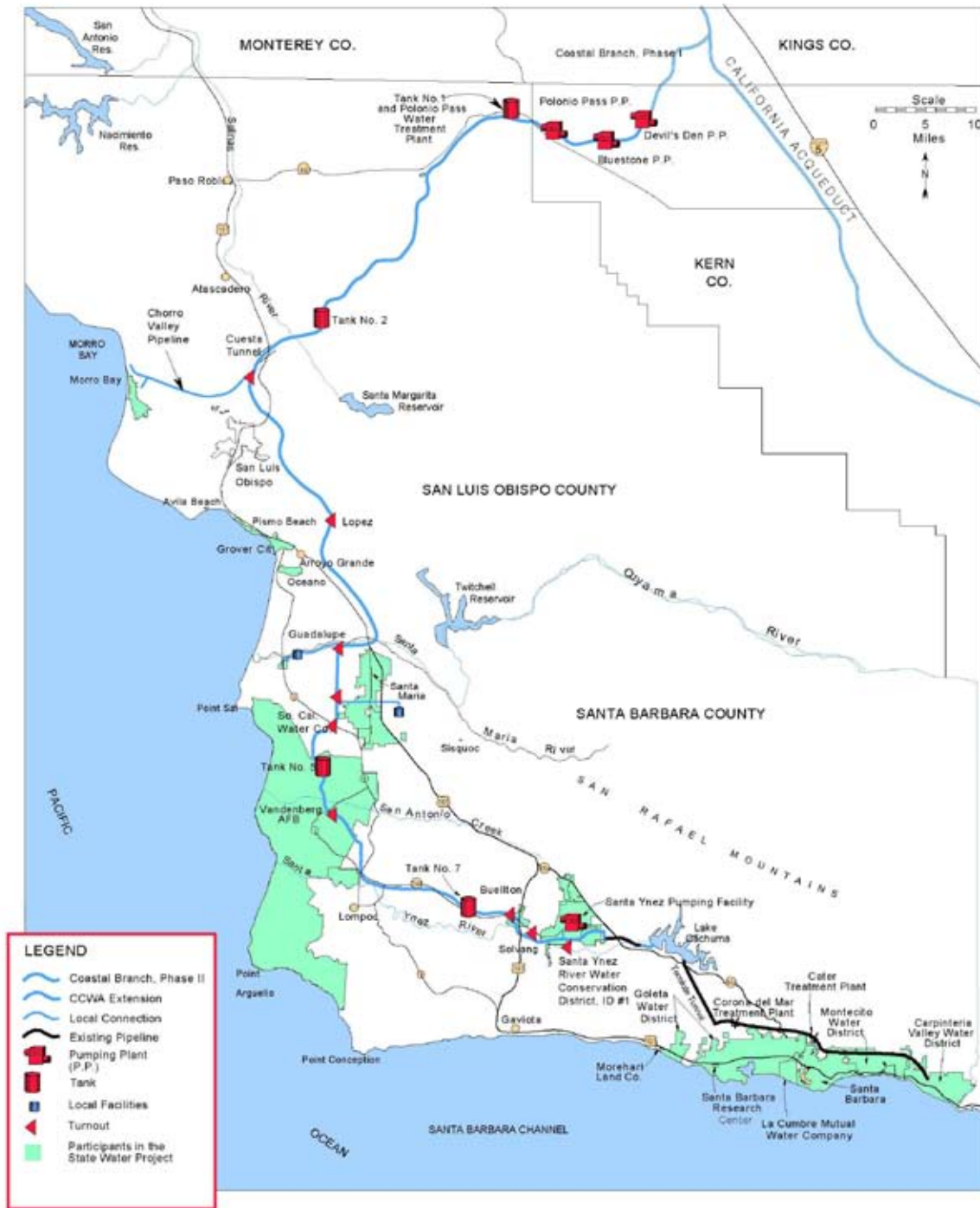

**Figure 2**  
**COASTAL BRANCH**  
**STATE WATER PROJECT**  
 LOS OSOS WASTEWATER PROJECT DEVELOPMENT  
 SAN LUIS OBISPO COUNTY

Presently the peak seasonal requirements of the City of Morro Bay take up all the capacity of the Chorro Valley pipeline. Therefore, Los Osos would have to pump during off peak seasons to take advantage of any available capacity for importing water.<sup>1</sup>

Connecting to State Water could pose several engineering, environmental, contractual, financial, and public sentiment challenges. This technical memorandum serves only as an initial exploratory exercise, and further detailed analysis would be necessary to formulate a plan for connecting to State Water if this option is explored further. Presented in the following paragraphs is a discussion of possible pipeline alignment, environmental impacts, reliability of state water, initial cost estimates, contractual issues, and public sentiment regarding State Water.

#### **4.1.2 Pipeline Alignment and Connection**

Shown on Figure 3 is one alternative alignment for bringing State Water into Los Osos. An approximate 3-mile pipeline would be designed and constructed from the Chorro Valley pipeline to Los Osos.

A turnout (in the form of a tee with a blind flange) exists for Los Osos on the Chorro Valley pipeline at South Bay Boulevard. The Public Works Department at the County has indicated the size of the tee to be 10 inches diameter. The proposed connection to the State Water Project ties into this turnout, and runs along South Bay Boulevard into Los Osos.

#### **4.1.3 Environmental Impacts of Proposed Pipeline Alignment**

The pipeline route shown in Figure 3 passes through Morro Bay State Park. However, South Bay Boulevard is owned partly by the County of San Luis Obispo, and partly by the City of Morro Bay. Thus running the pipeline along South Bay Boulevard would require the permission of both the County and the City of Morro Bay, and not of the State Park<sup>2</sup>. However, since the pipeline would be running adjacent to sensitive habitat, it would likely require additional environmental impact assessment and numerous mitigation measures during construction.

It is likely that permits would need to be obtained from the California Coastal Commission, California Department of Fish and Game, and the US Army Corps of Engineers.

It is difficult to predict how obtaining the above permits would impact project schedule without a full analysis of the environmental impact of the pipeline route conducted by an EIR consultant. However, it is anticipated that negotiation of regulatory permits of this or some similar alignment would take over a year.



---

<sup>1</sup> Based on phone conversation with San Luis Obispo County Public Works staff.

<sup>2</sup> Based on phone conversations with the staff of Crawford Multari and Clark Associates, and San Luis Obispo County Public Works staff.





LEGEND	
	Chorro Valley Turnout (existing facility)
	Proposed Pipeline Alignment to Los Osos (new facility)

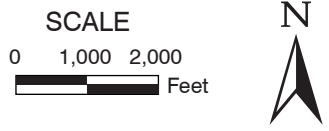

**Figure 3**  
**PROPOSED CONNECTION TO STATE WATER PROJECT**  
**LOS OSOS WASTEWATER PROJECT DEVELOPMENT**  
**SAN LUIS OBISPO COUNTY**

#### **4.1.4 Reliability of State Water**

Reliability of a new water supply is an important consideration for any community both from a standpoint of water quality and quantity.

##### **4.1.4.1 *Water Quality***

The SWP Coastal Branch is treated to Department of Public Health (DPH) drinking water standards at the Polonio Pass Water Treatment Plant using advanced coagulation, activated carbon filters, chlorine, and chloramines. Algae, taste and odor, and disinfection byproduct formation are potential issues connected to water quality that may affect recipients of State Water Project.<sup>3</sup> That being said, treated water delivered from the Coastal Branch Aqueduct meets all the primary and secondary drinking water standards for potable water.

##### **4.1.4.2 *Water Quantity***

Connecting to State Water inherently brings a question on reliability of supply. The original Water Service Agreement of the SWP had in it "Table A amounts" - the maximum a SWP participant could request in a year. In any year, the SWP allocates amounts in proportion to the Table A amounts, however the Table A amount is not guaranteed. Thus a Table A amount is not the amount of water received by an SWP customer, rather it is representative of the participant's allocation of State Water.

As seen on Figure 4, the probability of receiving all of Table A amount is only 28 percent in any single year. On an average annual basis, the reliability is about 74 percent based on the State Water Project Delivery Reliability Report 2005. Thus many SWP contractors have established Table A amounts in excess of their actual delivery needs, and this extra amount is called a "drought buffer". Based on recent court decisions addressing environmental issues in the Delta, where the water is pumped into the SWP system, initial SWP delivery amounts for 2008 were planned at only 25 percent of their Table A amount, and have been only recently increased to 35 percent.

Since SWP delivery amounts vary each year, it is assumed that Los Osos is likely to contract for a drought buffer in addition to 900 AFY. Contractors of State Water contract for drought buffers of various amounts and for the purposes of this technical memorandum, it is assumed that Los Osos would contract for a Table A amount of 900 AFY, and a drought buffer of 320 AFY. An average delivery of 74 percent of Table A amounts is assumed, based on the State Water Project Delivery Reliability Report 2005.

---

<sup>3</sup> As per Evaluation of Supplemental Alternatives Technical Memorandum No. 1 Constraints Analysis by Boyle Engineering Corporation for the Nipomo Community Services District.

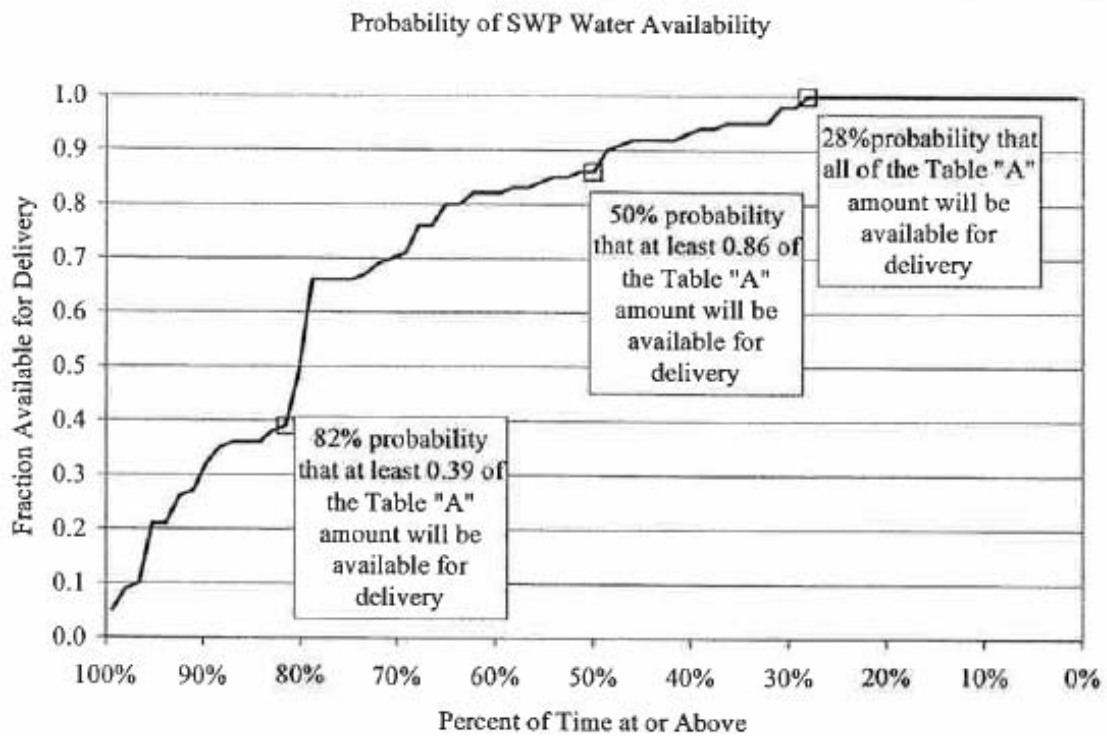

Source: The State Water Project Delivery Reliability Report 2005, April 2006

**Figure 4**  
**SWP DELIVERY RELIABILITY**  
 LOS OSOS WASTEWATER PROJECT DEVELOPMENT  
 SAN LUIS OBISPO COUNTY

#### 4.1.5 Cost of State Water

The cost of State Water consists of the following three components:

- Buy-in costs: This is the amount paid for the past capital improvements made by the seller. As this is a negotiated cost, it is difficult to predict the amount. However, it is likely to be on the order of \$15,000-\$20,000/AFY<sup>4</sup>. This would be paid for the contracted amount, or the “Table A amount”.
- Annual costs: This is the amount paid for the water used in that particular year, and is estimated to be approximately \$1,180/AF<sup>5</sup>.
- Drought buffer costs: this is the amount paid for the drought buffer allocation and is approximately \$75/AF.

State Water Project costs are summarized in Table 2.

<b>Table 2 State Water Cost Estimates Los Osos Wastewater Project Development San Luis Obispo County</b>								
Mitigation	Amount of Water to be Imported <sup>(1)</sup>	Contractual Table A Amount	Contractual Drought Buffer Allocations	Buy-In Costs		Pipeline Costs <sup>(3)</sup>	Annual Costs for 900 AFY <sup>(4)</sup>	Annual Drought Buffer Costs <sup>(5)</sup>
				At \$15,000/AFY <sup>(2)</sup>	At \$20,000/AFY <sup>(2)</sup>			
Level 1 - Level 3	900 AFY	900 AFY	320 AFY	\$13.5 million	\$18 million	\$2.3 million	\$1.1 million	\$24,000
Notes:								
(1) Assumes that the goal of importing water is to achieve mitigation to a balanced basin.								
(2) Range of possible buy-in costs as per phone conversation with San Luis Obispo County Public Works staff, based on an analysis sponsored by the City of Santa Maria.								
(3) Assumes approximate length of pipeline of 4 miles.								
(4) Multiplying 900 AFY by \$1,180/AF.								
(5) Multiplying 320 AFY by \$75/AF.								

##### 4.1.5.1 *Cost of Pipeline*<sup>6</sup>

The length of pipeline from the turnout on the Chorro Valley pipeline to Los Osos is approximately 3 miles. Delivering an average of 900 AFY would require sizing the pipe for 1,120 gpm (1,800 AFY), which assumes delivery of maximum day demands with a peaking factor of 2 for average demand of 560 gpm (900 AFY). A pipeline size of 8-inch diameter is appropriate.

This diameter may vary slightly depending on the actual peaking factor required to pump during City of Morro Bay off-peak seasons, but the impact on costs likely would be minimal.

<sup>4</sup> Estimate from phone conversation with San Luis Obispo County Public Works staff based on an analysis sponsored by the City of Santa Maria.

<sup>5</sup> This amount reflects the average of actual costs paid by State Water Project customers on the Chorro Valley Pipeline.

<sup>6</sup> These are construction cost estimates only, and do not include permitting costs, CEQA costs, design costs, and other project implementation costs.

It is also assumed at this time that AWWA PVC pipe would be appropriate for this transmission pipeline. Applying a unit cost estimate of \$110/LF<sup>7</sup>, and a 30 percent contingency, the cost of 3 miles of 8-inch diameter C900 PVC pipe Class 150 is \$2.3 million. Trenching, backfill, compaction, and "T" Top trench repair (paving 1 ft outside the trench on either side) are included in the per linear foot pipe cost.

These are construction cost estimates only, and do not include permitting costs, CEQA costs, design costs, and other project implementation costs.

#### **4.1.6 Contractual Issues with Connecting to State Water**

To receive State Water, Los Osos water purveyor(s) would have to enter into agreements with San Luis Obispo County Flood Control and Water Conservation District (District), but additional agreements would be needed by the District to provide it with the contractual ability to deliver SWP water to Los Osos. Particularly, District would have to negotiate agreements with Santa Barbara County Flood Control and Water Conservation District, the California Department of Water Resources, and the Central Coast Water Authority. Alternatively, acquiring the rights of existing SWP participant who was under-utilizing its allocation is possible although no interested 'sellers' are known. It is also important to note that local agencies do not control the decision making process for State Water and as a result, "local control" of the water resource is further removed. The outcome of these efforts, if pursued, is speculative at this time.

## **4.2 Nacimiento Water**

In 1959 the San Luis Obispo County Flood Control and Water Conservation District (District) obtained the rights to 17,500 AFY water from Lake Nacimiento. On January 7, 2008, construction commenced on the 45 mile pipeline that will convey untreated water from Lake Nacimiento to Paso Robles, Templeton, Atascadero, San Luis Obispo, and County Service Area 10, Zone A (CSA 10A), which supplies water to Southern Cayucos. Figure 5 shows a map of the project.

The Nacimiento project does not serve water to CSA 10 directly via the Nacimiento pipeline. By a process of exchange, CSA 10 and the City of San Luis Obispo exchange rights to water from the Whale Rock Reservoir and the Nacimiento pipeline. Thus, the City of San Luis Obispo withdraws less water from the Whale Rock Reservoir, and compensating for this amount from Nacimiento, allows CSA 10 to withdraw that share from Whale Rock Reservoir. CSA 10A's Nacimiento water is then delivered to the City for its use.

---

<sup>7</sup> Engineer's estimate made in 2007 for Potable Water Distribution System Upgrade for Department of Corrections and Rehabilitation , California Men's Colony, San Luis Obispo. The estimate includes a contingency of 30 percent.

#### **4.2.1 Bringing Nacimiento Water to Los Osos**

New facilities would need to be constructed to bring Nacimiento Water to Los Osos. Since facilities up to the City of San Luis Obispo are already being planned, the new facilities would have to start there.

The Nacimiento project serves raw water to its customers, and thus Los Osos would have to treat the water before it could be used for potable demand, or use the water for groundwater recharge into the lower aquifer.

While Los Osos could explore collaboration opportunities for required treatment with the City of San Luis Obispo or California Men's Colony, it was assumed in this technical memorandum that treatment would be provided by Los Osos, and thus the cost of treatment is included in the assessment of the cost of this alternative.

#### **4.2.2 Pipeline Alignment and Connection**

The proposed pipeline alignment for bringing Nacimiento water into Los Osos would connect somewhere upstream of the City of San Luis Obispo Water Treatment Plant, down Foothill Boulevard to Los Osos Valley Road and into the Los Osos system. This would require approximately an 11-mile pipeline as shown on Figure 6.

#### **4.2.3 Environmental Impacts of Proposed Pipeline Alignment**

The pipeline route shown on Figure 6 passes along Los Osos Valley Road, and along Foothill Boulevard. The route is not as environmentally sensitive as the proposed State Water Project line, and would potentially only require permits from the California Department of Fish and Game and the US Army Corps of Engineers.

#### **4.2.4 Cost of Nacimiento Water**

The City of San Luis Obispo is paying a capital cost of about \$22,000/AFY for Nacimiento Water. The Operations and Maintenance (O&M) cost for the first year is estimated to be approximately \$400/AFY<sup>8</sup>. It is reasonable to assume that Los Osos would pay at least the same amount of capital and O&M cost as the City of San Luis Obispo.

##### ***4.2.4.1 Cost of Pipeline***

The length of pipeline along the proposed alignment is approximately 11 miles. Delivering an average of 900 AFY would require sizing the pipe for 1,120 gpm (1,800 AFY) which assumes delivery of maximum day demands with a peaking factor of 2 for average demand 560 gpm (900 AFY). A pipeline size of 8-inch diameter is appropriate. It is also assumed at

---

<sup>8</sup> As per phone conversation with the Project Manager of the Nacimiento Water Project at County of San Luis Obispo.

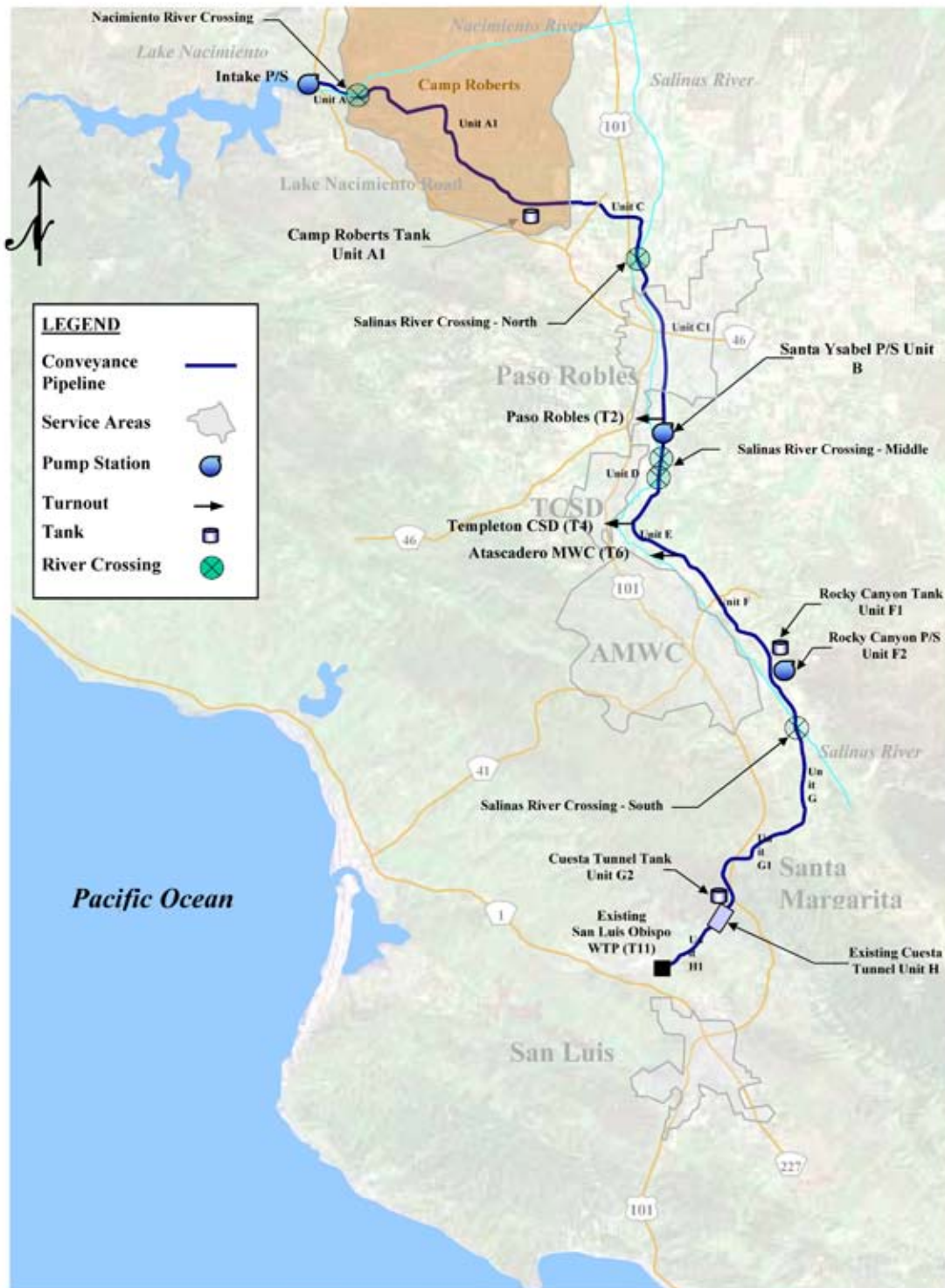

**Figure 5**  
**UNIT MAP FOR NACIMIENTO WATER PROJECT**  
**LOS OSOS WASTEWATER PROJECT DEVELOPMENT**  
**SAN LUIS OBISPO COUNTY**

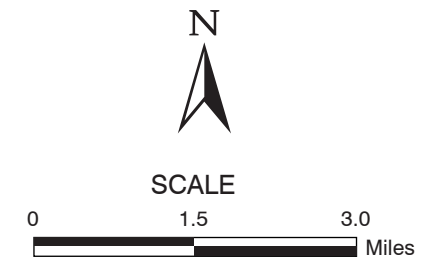
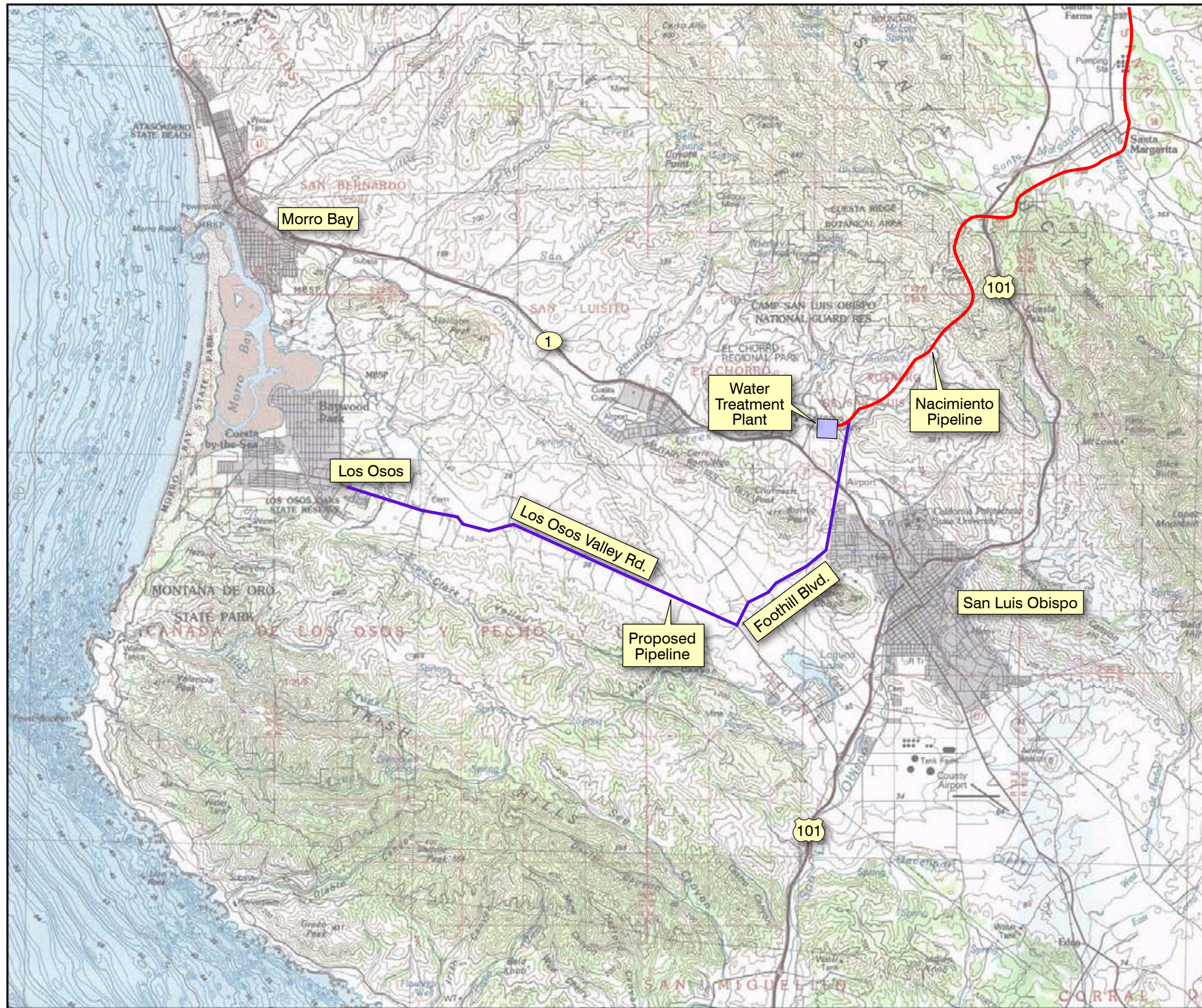

LEGEND	
<span style="color: red;">—</span>	Nacimiento Pipeline (existing facility)
<span style="color: blue;">—</span>	Alignment Alternative (new facility)

**Figure 6**  
**PROPOSED CONNECTION TO**  
**NACIMIENTO WATER PROJECT**  
**LOS OSOS WASTEWATER PROJECT DEVELOPMENT**  
**SAN LUIS OBISPO COUNTY**



this time that AWWA PVC pipe would be appropriate for this transmission pipeline. Applying a unit cost estimate of \$110/LF<sup>9</sup> and a 30 percent contingency, the cost of 11 miles of 8-inch diameter C900 PVC pipe Class 150 is \$8.3 million. Trenching, backfill, compaction, and "T" Top trench repair (paving 1 foot outside the trench on either side) are all included in the per linear foot pipe cost.

These are construction cost estimates only, and do not include permitting costs, CEQA costs, design costs and other project implementation costs. The estimate includes a contingency of 30 percent.

#### **4.2.4.2 Cost of Treatment Plant**

Assuming that Los Osos builds its own treatment plant to treat Nacimiento water, and assuming a treatment plant of size 2 mgd (1.0 mgd average day, 2.0 mgd maximum day), and a planning level treatment plant cost of \$4/gpd, the construction cost of the treatment plant is estimated to be \$8.0 million. These are construction cost estimates only, and do not include permitting costs, CEQA costs, design costs and other project implementation costs. The estimate includes a contingency of 30 percent. An alternative could be that the raw Nacimiento water gets treated at the City of San Luis Obispo and then piped to Los Osos. In this case, costs would need to be negotiated with the City of San Luis Obispo. A second alternative could be that the water would be treated at upgraded CMC facilities and piped down the Chorro Valley pipeline.

#### **4.2.5 Contractual Issues with Connecting to Nacimiento Water**

The City of San Luis Obispo has contracted for the amount of Nacimiento Water that it needs for buildout, so the scope of negotiations to purchase some of the City's allocation of Nacimiento water might be limited at present. Also, since the participants of the Nacimiento project are obliged to pay for the full contractually agreed amount irrespective of actual demand, it is anticipated that the City of San Luis Obispo is going to use its maximum Nacimiento allotment before using other sources.

An alternative Nacimiento delivery configuration for Los Osos would be similar to that of CSA 10, by negotiating an exchange of Nacimiento contract water with the Whale Rock supply. However, the City of San Luis Obispo optimizes its water supply by applying its "conjunctive use model" which uses the flexibility of many sources to maximize supply. It also has a "multi-source water policy" which improves the reliability of its water supply by diversifying its sources. Thus any agreement which hampered the diversity of its sources, by making the City give up its use of another source (such as Whale Rock Reservoir) could defeat the purpose of having a new diversified supply in the first place.<sup>10</sup>

---

<sup>9</sup> Engineer's estimate made in 2007 for Potable Water Distribution System Upgrade for Department of Corrections and Rehabilitation, California Men's Colony, San Luis Obispo.

<sup>10</sup> As per telephone conversations with San Luis Obispo County Public Works staff, and the Water Division Manager of the City of San Luis Obispo.

A supplemental EIR would need to be prepared for Los Osos to receive Nacimiento water, and it would require that at least 55 percent of participating agencies agree to the proposed project. Thus participating in the Nacimiento project could prove to be a lengthy and complicated process requiring a negotiation with several parties. In addition, it would require Los Osos to get into the water treatment plant operations business.

## **5.0 SUMMARY**

Imported water is anticipated to offset potable water demand from the groundwater basin. Consideration of State water or Nacimiento water would require a complete environmental review by the water purveyors as per the California Environmental Quality Act (CEQA). This technical memorandum summarizes the evaluation of imported water as an option for mitigating sea water intrusion (SWI) in the Los Osos groundwater basin. Imported water does not forgo the need for wastewater disposal. Therefore, to evaluate the total cost to the community for wastewater disposal and SWI mitigation, any imported water option would be paired up with a disposal option for comparison to other alternatives. The reuse projects that provide a fair comparison to imported water are those that provide seawater intrusion mitigation benefits similar to importing water by offsetting pumping on the West side of the basin. These comparable options include urban reuse and agricultural exchange (using recycled water for agricultural demand and transporting potable water from the East side to the West side, thereby offsetting pumping from the West side of the basin).

Both alternatives of importing water will involve a lengthy negotiation process that would take a considerable amount of time and effort from all involved parties. Both options would require additional facilities to be built, although Nacimiento could require a longer pipeline, and a treatment plant as compared with State water.

A cost comparison of the two alternatives is shown in Table 3. Note that these are construction cost estimates only, and do not include all contingencies, permitting costs, CEQA costs, design costs and other project implementation costs.

Notwithstanding the institutional and cost barriers to an expedient solution, public sentiment also plays a large role in the decision making process. Development could potentially be fueled by importing water into rural lands. These issues should be addressed as part of the EIR.

<b>Table 3 Summary of Imported Water Costs Los Osos Wastewater Project Development San Luis Obispo County</b>		
<b>Project</b>	<b>State Water</b>	<b>Nacimiento Water</b>
<b>Initial costs</b>		
Buy- in cost	\$13.5 - \$18 million <sup>(1)</sup>	\$19.8 million <sup>(2)</sup>
Pipeline cost	\$2.3 million <sup>(3)</sup>	\$8.3 million <sup>(3)</sup>
Treatment cost	\$0	\$8.0 million <sup>(3)</sup>
<b>Total Initial Cost</b>	<b>\$ 15.8 - \$20.3 million</b>	<b>\$36.1 million</b>
<b>Annual Costs<sup>(4)</sup></b>		
Cost of 900 AF <sup>(5)</sup>	\$1.1 million	0.36 million
Drought Buffer Costs	\$24,000	
<b>Total Annual Cost</b>	<b>\$ 1.1 million</b>	<b>0.36 million</b>
Notes:		
(1) As per telephone conversation with County of San Luis Obispo County Works staff based on a study sponsored by the City of Santa Maria, the buy-in costs of SWP could be as high as \$15,000 to \$20,000 per AFY, and multiplying by 900 AFY.		
(2) As per telephone conversation with the County Project Manager for the Nacimiento project, these are the costs of Nacimiento water for the City of San Luis Obispo.		
(3) As per engineer's estimate, costs do not include all contingencies, permitting, CEQA, design and other project implementation costs.		
(4) Annual costs shown are for contractual costs for purchase of imported water supply only, and do not include O&M costs for Project owned community facilities such as pipelines and treatment plant.		
(5) 900 AFY is the volume of imported water required to achieve mitigation level 3 to reach a balanced basin. The annual costs are for the purchase of water only, and do not include the costs for pumping or treating the water.		

# Los Osos Wastewater Project Preliminary Engineering Report

Prepared for:



Mike Starinsky, Civil Engineer  
430 G Street, Agency 4169  
Davis, CA 95616-4169

Prepared by:



John Waddell, Project Engineer  
RCE No. 66846, Exp. 9/30/2010  
San Luis Obispo County  
Department of Public Works  
County Gov't Center, Room 207  
San Luis Obispo, CA 93408  
p (805) 781-5252 f (805) 781-1229



May 2010



**TABLE OF CONTENTS**

**CHAPTER 1: PROJECT SUMMARY** ..... 1

1.1. BACKGROUND ..... 1

1.2. EARLY PROJECT EFFORTS BY COUNTY ..... 1

1.3. LOS OSOS COMMUNITY SERVICES DISTRICT..... 2

1.4. CURRENT COUNTY EFFORTS UNDER AB 2701 (BLAKESLEE, 2006) ..... 2

1.5. SUMMARY OF APPROVED PROJECT..... 3

**CHAPTER 2: PROJECT PLANNING AREA** ..... 8

2.1. INTRODUCTION ..... 8

2.2. LOCATION ..... 8

2.3. ENVIRONMENTAL RESOURCES PRESENT ..... 12

2.4. GROWTH AREAS AND POPULATION TRENDS..... 19

2.5. ECONOMIC DEMOGRAPHICS..... 20

**CHAPTER 3: EXISTING FACILITIES**..... 22

**CHAPTER 4: NEED FOR PROJECT** ..... 24

4.1. INTRODUCTION ..... 24

4.2. HEALTH, SANITATION AND SECURITY ..... 25

4.3. SYSTEM OPERATIONS AND MAINTENANCE..... 26

4.4. GROWTH/BUILD-OUT FLOWS AND LOADS PROJECTIONS ..... 26

**CHAPTER 5: ALTERNATIVES CONSIDERED** ..... 28

5.1. INTRODUCTION ..... 28

5.2. APPROACH TO ALTERNATIVES ANALYSIS ..... 28

5.3. ALTERNATIVES DESCRIPTION..... 32

5.4. EVALUATION CRITERIA ..... 46

5.5. MAPS..... 54

5.6. ENVIRONMENTAL IMPACTS..... 59

5.7. CARBON FOOTPRINT/GREENHOUSE GAS EMISSIONS ..... 59

5.8. PUBLIC PARTICIPATION/COMMUNITY SURVEY ..... 61

5.9. LAND REQUIREMENTS..... 61

5.10. CONSTRUCTABILITY ISSUES ..... 62

5.11. COST ESTIMATES ..... 63

5.12. ADVANTAGES/DISADVANTAGES ..... 76

**CHAPTER 6: SELECTION OF AN ALTERNATIVE**..... 87

6.1. INTRODUCTION ..... 87

6.2. PRESENT WORTH COST ANALYSIS..... 87

6.3. NON-MONETARY FACTORS CONSIDERED..... 91

**CHAPTER 7: PROPOSED PROJECT (RECOMMENDED ALTERNATIVE)** ..... 95

7.1. INTRODUCTION ..... 95

7.2. PROJECT DESIGN ..... 95

7.3. TOTAL PROJECT COST ESTIMATE..... 101

7.4. ANNUAL OPERATION BUDGET..... 103

**CHAPTER 8: CONCLUSIONS AND RECOMMENDATIONS**..... 119

**REFERENCES**..... 122

**APPENDICES**

- Appendix A: Los Osos Community Services District Collection System Bid Results 2/24/2005  
Appendix B: [Viable Project Alternatives: Fine Screening Analysis](#), Carollo Engineers, in association with Crawford, Multari & Clark Associates and Cleath and Associates; August 2007. (Under Separate Cover)  
Appendix C: [Engineer’s Report for the San Luis Obispo County Wastewater Assessment District No. 1](#), Wallace Group; December 2007. (Under Separate Cover)

**LIST OF TABLES**

2.1	Year 1990, Year 2000, and Build-out Population and Housing Data for Community of Los Osos.....	19
2.2	Employment Status – Los Osos, CA .....	20
2.3	Household Income – Los Osos, CA.....	20
4.1	Projected Wastewater Generation Rates.....	27
4.2	Gravity collection System Wastewater Characteristics .....	27
5.1	Los Osos Wastewater Project Core Community Values .....	30
5.2	Treatment Facility Site Requirements and Issues.....	51
5.3	Greenhouse Gas Emissions Summary: Annual Metric Tons of CO <sub>2</sub> Equivalent .....	60
5.4	Range of Probable Costs for Gravity Collection System.....	64
5.5	Range of Probable Costs for Low Pressure Collection System (LPCS).....	66
5.6	Range of Probable Costs for STEP/STEG Collection System .....	67
5.7	Estimated O & M Costs for Gravity Collection System.....	68
5.8	Estimated O & M Costs for Low Pressure Collection System (LPCS).....	68
5.9	Estimated O & M Costs for STEP/STEG Collection System.....	69
5.10	Summary of Treatment Alternative Costs .....	70
5.11	Capital Cost Summary for Solids Treatment Alternatives .....	71
5.12	O & M Cost Summary for Solids Treatment Alternatives .....	72
5.13	Capital Cost Summary for Effluent Reuse and Disposal Alternatives .....	73
5.14	O & M Cost Summary for Effluent Reuse and Disposal Alternatives .....	73
5.15	Total Project Capital Cost Summary (\$ Millions).....	74
5.16	Total Project O & M Cost Summary (\$ Millions) .....	75
5.17	Collection System Alternatives – Advantages, Disadvantages and Issues.....	76
5.18	Treatment Process Alternatives – Advantages, Disadvantages and Issues.....	78
5.19	Effluent Reuse and Disposal Alternatives – Advantages, Disadvantages and Issues.....	80
5.20	Solids Handling Alternatives – Advantages, Disadvantages and Issues .....	81
5.21	Treatment Facility Site Alternatives – Advantages, Disadvantages and Issues .....	82
6.1	Collection System Alternatives Present Worth (\$ Million).....	87
6.2	Solids Handling Alternatives Present Worth (\$ Million) .....	88
6.3	Treatment Process Alternatives Present Worth (\$ Million).....	88
6.4	Effluent Reuse and Disposal Alternatives Present Worth (\$ Million).....	89
6.5	Project Soft Costs Present Worth (\$ Million).....	90
6.6	Present Worth Comparison for Project Combinations of Apparent Low Cost Alternatives.....	90

**LIST OF TABLES (CONTINUED)**

7.1	Collection System Information .....	96
7.2	Total Project Capital Cost Estimate .....	101
7.3	Estimated Total Revenue Requirements .....	103
7.4	Example Total Monthly Cost by User Group .....	104
7.5	Assessment Benefit Unit Allocation .....	105
7.6	Assessment Benefit Unit Weighted Average (EDU's) .....	105
7.7	Example Assessment Charges by User Group .....	105
7.8	User Charges EDU's .....	106
7.9	Example User Charges by User Group .....	106
7.10	Estimated Annual O & M Costs for Gravity Collection System .....	107
7.11	Estimated Annual O & M Costs for Treatment Process .....	107
7.12	Estimated Annual O & M Costs for Biosolids Processing .....	108
7.13	Estimated Annual O & M Costs for Recycled Water Reuse .....	108
7.14	Summary of Total Project Annual O & M Cost Estimate .....	109
7.15	Estimated Annual Debt Service .....	110
7.16	Short-Lived Asset Reserves .....	111

**LIST OF FIGURES**

1.1	Vicinity Map .....	5
1.2	Project Setting .....	6
1.3	Project Diagram .....	7
2.1	Los Osos Area Topography .....	9
2.2	Los Osos Planning Areas .....	10
2.3	Los Osos Water Purveyors, Urban Services Line, and Prohibition Zone .....	11
2.4	Environmental Setting .....	13
2.5	Special Status Species Habitat .....	14
2.6	Jurisdictional Waters and Wetlands .....	15
2.7	SRA and ESHA Lands .....	16
2.8	Archaeological Sensitive Areas .....	17
2.9	Agricultural Soils and Williamson Act Status .....	18
2.10	Population and Median Household Income .....	21
3.1	Location of Existing Neighborhood Septic and Sewer Systems .....	23
5.1	Project Diagram .....	55
5.2	Treatment Plant Site Alternatives .....	56
5.3	Out-of-Town Conveyance Route Alternatives .....	57
5.4	Effluent Disposal and Recycled Water Reuse Alternatives .....	58
6.1	Present Worth Comparison for Apparent Low Cost Alternatives .....	91
7.1	Treatment Facility Layout .....	97
7.2	Treatment Facility Administration Building Architectural Rendering .....	98
7.3	Treatment Facility Maintenance Building Architectural Rendering .....	99
8.1	Los Osos Affordability Threshold by 2000 Census Household Age Category .....	119
8.2	Benefits of Favorable USDA Financing .....	120





## **CHAPTER 1: PROJECT SUMMARY**

### **1.1. BACKGROUND**

The community of Los Osos, California is an unincorporated community situated about mid-way on the coastline of San Luis Obispo County, at the southern end of Morro Bay and adjacent to the Morro Bay National Estuary and State Marine Reserve. It is surrounded by Morro Bay, the Pacific Ocean, Montana de Oro State Park, open space preserves, and prime agricultural lands. The population of the community is approximately 15,000 residents. Drinking water is obtained by means of well extraction from the Los Osos groundwater basin, a multi-level aquifer underlying the Los Osos community. The basin is comprised of an upper and a lower aquifer separated by an impermeable layer of clay, which thereby restricts the vertical movement of groundwater.

The physical development of Los Osos began in the late 19<sup>th</sup> Century with the division of land into a grid of long, narrow residential lots located on wide streets. By the early 1960's, a community of summer homes and retreats had been developed. The community's permanent population grew steadily during the 1970's and into the mid-1980's, with the absence of a central wastewater collection and treatment system. Consequently, sanitation needs were met primarily through individual septic systems with septic pits, leachfields and similar methods. Today, wastewater treatment for the community continues to consist of privately owned, individual septic systems serving each developed property, or in some cases multiple properties.

The Regional Water Quality Control Board – Central Coast Region (RWQCB) determined in 1983 that contamination in excess of the State standards had occurred in the groundwater basin (upper aquifer) at least partially due to use of the septic systems throughout the community. Therefore, in January 1988, the State Water Resources Control Board approved an amendment to the Water Quality Control Plan, Central Coastal Basin. The amendment contained the discharge moratorium established by the RWQCB for a portion of the Los Osos area known as the “Prohibition Zone” (Figure 2-2). By prohibiting discharge from additional individual and community sewage disposal systems, the moratorium effectively halted new construction or major expansions of existing development until the water pollution problem was solved. In effect, the regulatory actions necessitated the development of a community wastewater system to collect, treat, and dispose/reuse the wastewater.

### **1.2. EARLY PROJECT EFFORTS BY COUNTY**

Since the establishment of the Prohibition Zone, there have been many attempts to rectify the situation through construction of a wastewater project. The County produced a plan and Environmental Impact Report (EIR) by 1987 for a wastewater treatment system that was composed of conventional collection, treatment and disposal technologies, with the treatment plant site located in a rural area northeast of the community near the westerly end of Turri Road. The County prepared a Supplemental EIR in 1988 and began the design process. However, the project was delayed by litigation and other issues. By the mid-1990's the planned treatment plant site was moved to a partially developed area on the eastern side of the Los Osos community. This site change necessitated preparation of a second supplemental EIR (1997). For

a variety of reasons, the conventional wastewater collection and treatment system evaluated by the 1997 supplemental EIR, did not enjoy community-wide support. Overriding concerns with the project related to project costs and feasibility of the effluent disposal plan.

### 1.3. LOS OSOS COMMUNITY SERVICES DISTRICT

Community opposition to the County's planned project led to the formation of the "Solutions Group," a coalition of community members with a vision for an alternative sewer project. The plan included a STEP collection system, facultative pond treatment, and community amenities, such as a park, in the project description. In 1998, the community voted to establish a community services district with wastewater authority and elected members of the "Solutions Group" to the Board of Directors. The Los Osos Community Services District (LOCSD) prepared a project EIR, began the design process, and purchased a treatment plant site located in the west-central portion of the community (referred to as both the "Tri-W" and "Mid-Town" site). By the time the LOCSD certified the EIR in 2001, the alternative technologies had been removed in favor of a conventional gravity collection system and extended aeration treatment process.

The LOCSD did not receive final approval of the Coastal Development Permit (CDP) and start construction until mid-2005. By that time, there was growing community opposition to the project, focused primarily on project costs and the Mid-Town treatment plant site. In the fall of 2005, the voters in Los Osos recalled a majority of the LOCSD board members in a special election. The new board immediately halted construction on the wastewater project. In August 2006, the LOCSD rescinded certification of the 2001 EIR and filed for federal bankruptcy protection due to default on construction and financing contracts.

In response to the community vote to effectively stop the wastewater project, which was in construction, the RWQCB began to take regulatory enforcement action against individual property owners for violation of the septic tank discharge prohibition. The RWQCB initially sent Cease and Desist orders to 45 property owners and has subsequently sent a Notice of Violation to all property owners within the prohibition zone. The RWQCB established a deadline of January 1, 2011, after which property owners will face fines if substantial progress has not been made to complete the project.

### 1.4. CURRENT COUNTY EFFORTS UNDER AB 2701 (BLAKESLEE, 2006)

After the recall and suspension of construction, California Assemblyman Sam Blakeslee attempted to resolve the dispute between the State Water Board, which was the funding agency, and the LOCSD. When a compromise could not be reached, Assemblyman Blakeslee proposed special legislation, Assembly Bill (AB) 2701, to authorize transfer of wastewater authority from the LOCSD to the County of San Luis Obispo. AB 2701 was passed unanimously by the California State legislature and signed into law by Governor Arnold Schwarzenegger. It became effective on January 1, 2007.

Among its key provisions, AB 2701 required that the County determine whether property owners would authorize local assessments pursuant to Proposition 218, which is commonly referred to as

the “Right to Vote on Taxes Act” and which is incorporated into the California State Constitution. The County’s first task was the development of a Rough Screening Report and a Fine Screening Report. These documents focused on identifying a set of viable project alternatives and cost estimates for those alternatives. The cost estimates were the basis for the Proposition 218 assessment vote.

In October, 2007, the assessments were approved with 80% of property owner ballots in support. The assessments have since been established as liens on properties in an amount that varies by property but is equivalent to \$24,941 per single family dwelling unit and total \$126,722,296. Consequently, project funding has been substantially secured for the Los Osos Wastewater Project (LOWWP). A separate assessment ballot process for vacant properties is planned prior to the final implementation of the wastewater project. However, the liens assessed to developed properties in the 2007 proceedings represent approximately 78% of the total capital cost of the proposed project, including capitalized interest.

Following the successful Proposition 218 vote, the County completed a co-equal environmental review process to meet the requirements of the California Environmental Quality Act (CEQA) and the National Environmental Policy Act (NEPA). The project draft EIR was released in November, 2008, and the final EIR was adopted by the County Board of Supervisors on September 29, 2009. The County has also applied for all state and federal environmental permits; however, as a result of the “due-diligence” provisions of AB 2701, is waiting for final issuance of key permits, including the Coastal Development Permit, before proceeding with final design or project bids.

## 1.5. SUMMARY OF APPROVED PROJECT

The final approved project description in the EIR process consists of the following components:

### Collection System

A gravity collection system is planned for Los Osos. A full collection system design was completed by the Los Osos CSD in 2004, prior to their cessation of the project and the passage of AB 2701. This existing design is the basis of the current planning and environmental permitting process. The collection system will consist of the following:

- Approximately 45 miles of pipelines, plus service laterals
- Nine major duplex and triplex pump stations, all with stand-by power
- Thirteen “pocket” pump stations
- A 2.5 mile force main to convey raw wastewater from the service area to the treatment plant

### Treatment Facility

The planned treatment facility will be located on approximately 38 acres of the Giacomazzi property, located 2 miles east of the community core and behind the Los Osos cemetery. The

property is currently zoned agricultural. However, the soil is poor quality and is not regularly farmed. The treatment facility will be design for an average daily flow of 1.2 MGD and will consist of the following:

- Headworks and bar screens covered for odor control
- Extended aeration secondary treatment process designed to meet total nitrogen limit of 7 mg/L.
- Tertiary filter process with ultraviolet disinfection designed to meet California Title 22 standards for tertiary recycled water
- Mechanical sludge dewatering (belt filter press or screw press) enclosed in a building for odor control

#### Recycled Water Reuse Program

Recycled wastewater will be reused within the community or surrounding agricultural land overlying the groundwater basin. It will either be discharged through leachfields or directly reused for urban or agricultural irrigation. The reuse program will consist of the following:

- 50 acre-feet of storage at the treatment plant site
- A recycled water main running from the treatment plant site, through the adjacent agricultural area, to reuse sites within the community
- 8 acres of leachfields at the Broderson site, with an annual capacity of 450 acre-feet
- Utilize one acre of existing leachfields in the Bayridge Estates sub-division with an annual capacity of 32 acre-feet
- Provide recycled water to Los Osos schools, parks, golf course, and cemetery
- Provide recycled water main turn-outs to adjacent farmlands and develop reuse agreements for approximately 100 to 200 acre-feet per year.

#### Conservation Program

The project will also implement a water conservation program with a goal of reducing indoor water consumption to 50 gallons per capita per day, which is more than a 25% reduction over current use estimates. The conservation program will be accomplished through subsidized, mandatory residential and commercial fixture retrofits, appliance rebates, education, and water efficiency audits.

Figure 1.1 Vicinity Map



Source: Census 2000 Data, The CaSIL, MBA GIS 2008.

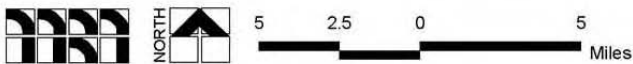

Michael Brandman Associates  
 02240002 • 11/2008 | 1-1\_project\_vicinity.mxd

Exhibit 1-1  
 Project Vicinity

COUNTY OF SAN LUIS OBISPO • LOS OSOS WASTEWATER PROJECT  
 ENVIRONMENTAL IMPACT REPORT

Figure 1.2 Project Setting



Source: AirPhoto USA, San Luis Obispo County GIS Data, and MBA GIS Data.



  
 2,000 1,000 0 2,000 Feet
   
 Michael Brandman Associates
   
 02240002 • 10/2008 | 1-2\_project\_setting.mxd

Exhibit 1-2  
Project Setting

COUNTY OF SAN LUIS OBISPO • LOS OSOS WASTEWATER PROJECT  
ENVIRONMENTAL IMPACT REPORT

Figure 1.3 Project Diagram

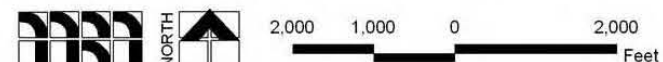
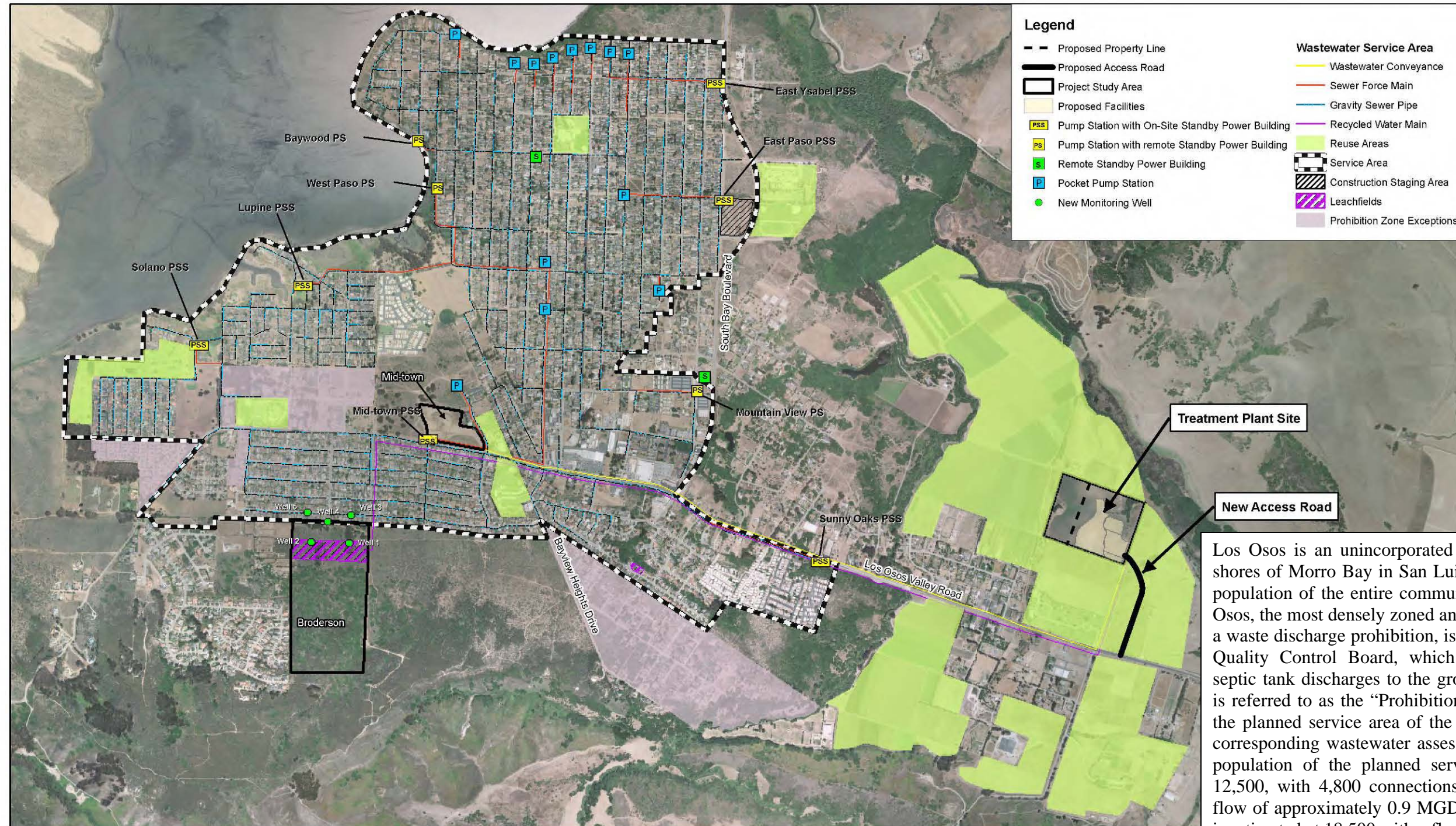

Los Osos is an unincorporated community located on the shores of Morro Bay in San Luis Obispo County, Ca. The population of the entire community is 14,500. Within Los Osos, the most densely zoned and developed areas are under a waste discharge prohibition, issued by the Regional Water Quality Control Board, which requires the cessation of septic tank discharges to the groundwater basin. This area is referred to as the "Prohibition Zone." It is the basis for the planned service area of the wastewater project and the corresponding wastewater assessment district. The current population of the planned service area is approximately 12,500, with 4,800 connections and an estimated start-up flow of approximately 0.9 MGD. The build-out population is estimated at 18,500 with a flow of 1.2 MGD.

Source: 2007 Digital Globe aerials, San Luis Obispo County GIS Data, Carollo Engineers, and MBA GIS Data.

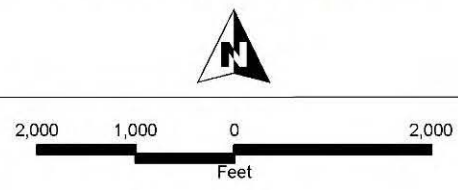

**Overall Project Site Plan**  
**Los Osos Wastewater Project, County of San Luis Obispo, 2009**  
 COUNTY OF SAN LUIS OBISPO • LOS OSOS WASTEWATER PROJECT



## CHAPTER 2: PROJECT PLANNING AREA

### 2.1. INTRODUCTION

Los Osos is an unincorporated community located on the shores of Morro Bay in San Luis Obispo County, Ca. The population of the entire community is 14,500. Within Los Osos, the most densely zoned and developed areas are under a waste discharge prohibition, issued by the Regional Water Quality Control Board, which requires the cessation of septic tank discharges to the groundwater basin. This area is referred to as the “Prohibition Zone.” It is the basis for the planned service area of the wastewater project and the corresponding wastewater assessment district. The current population of the planned service area is approximately 12,500, with 4,800 connections and an estimated start-up flow of approximately 0.9 MGD. The build-out population is estimated at 18,500 with a flow of 1.2 MGD.

### 2.2. LOCATION

The planned project facilities will be located both inside and outside the wastewater service area. Facilities in the service area include gravity sewer collectors, force mains, pump stations, recycled water mains, and recycled water reuse and disposal systems. The wastewater treatment plant, recycled water storage, and delivery pipelines will be located approximately one to two miles east of the service area. The following figures provide an overview of the community and facilities location.

Figure 2.1 Los Osos Area Topography

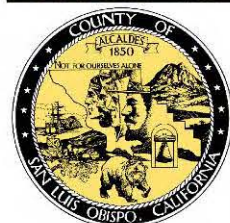
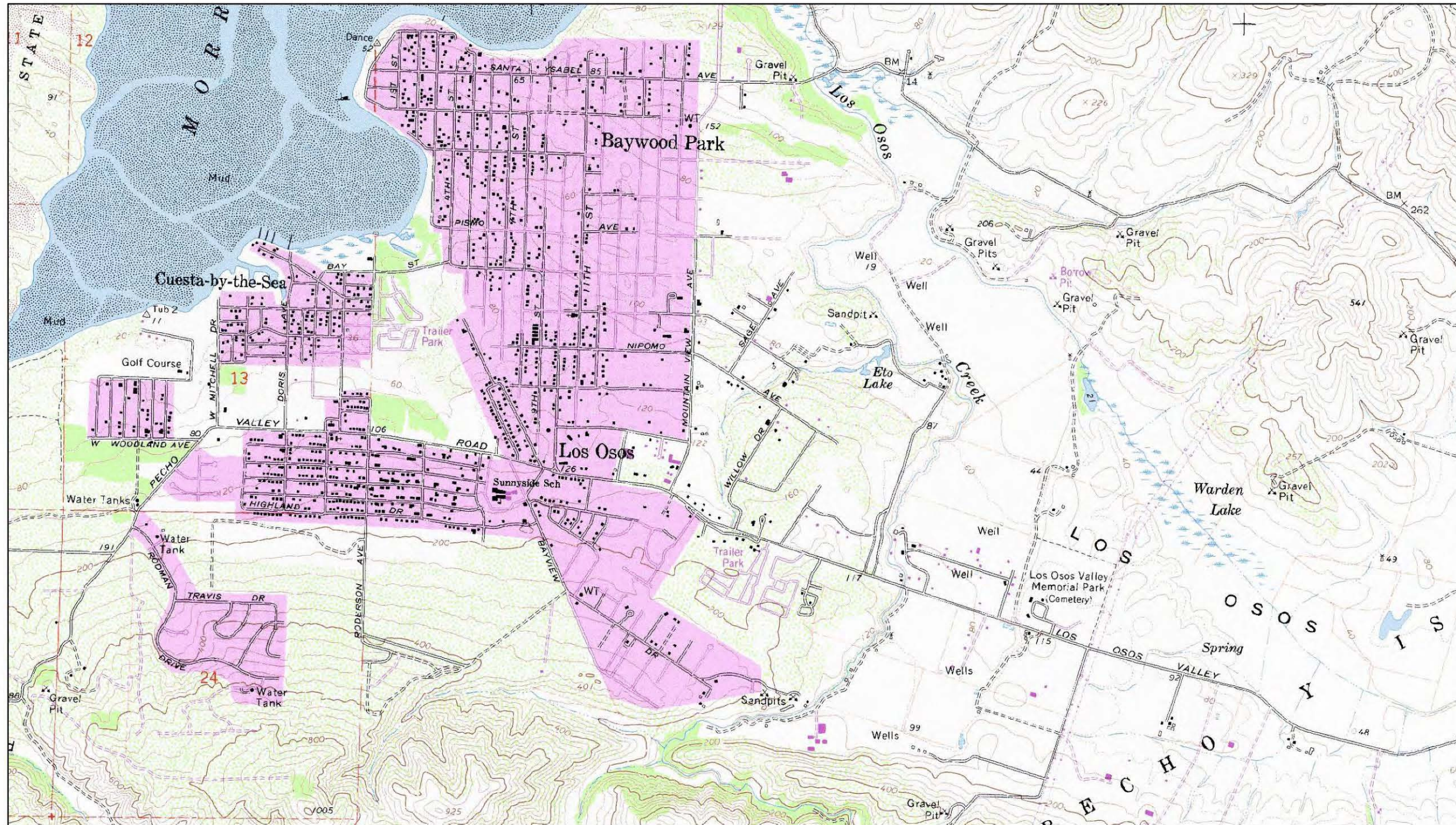

Source: USGS 7.5-minute Topographic Map

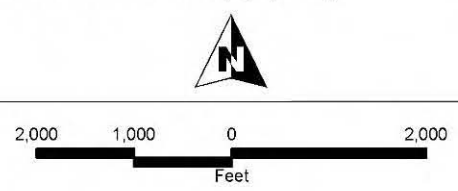

Topographic Map

COUNTY OF SAN LUIS OBISPO • LOS OSOS WASTEWATER PROJECT

Figure 2.2 Los Osos Planning Areas

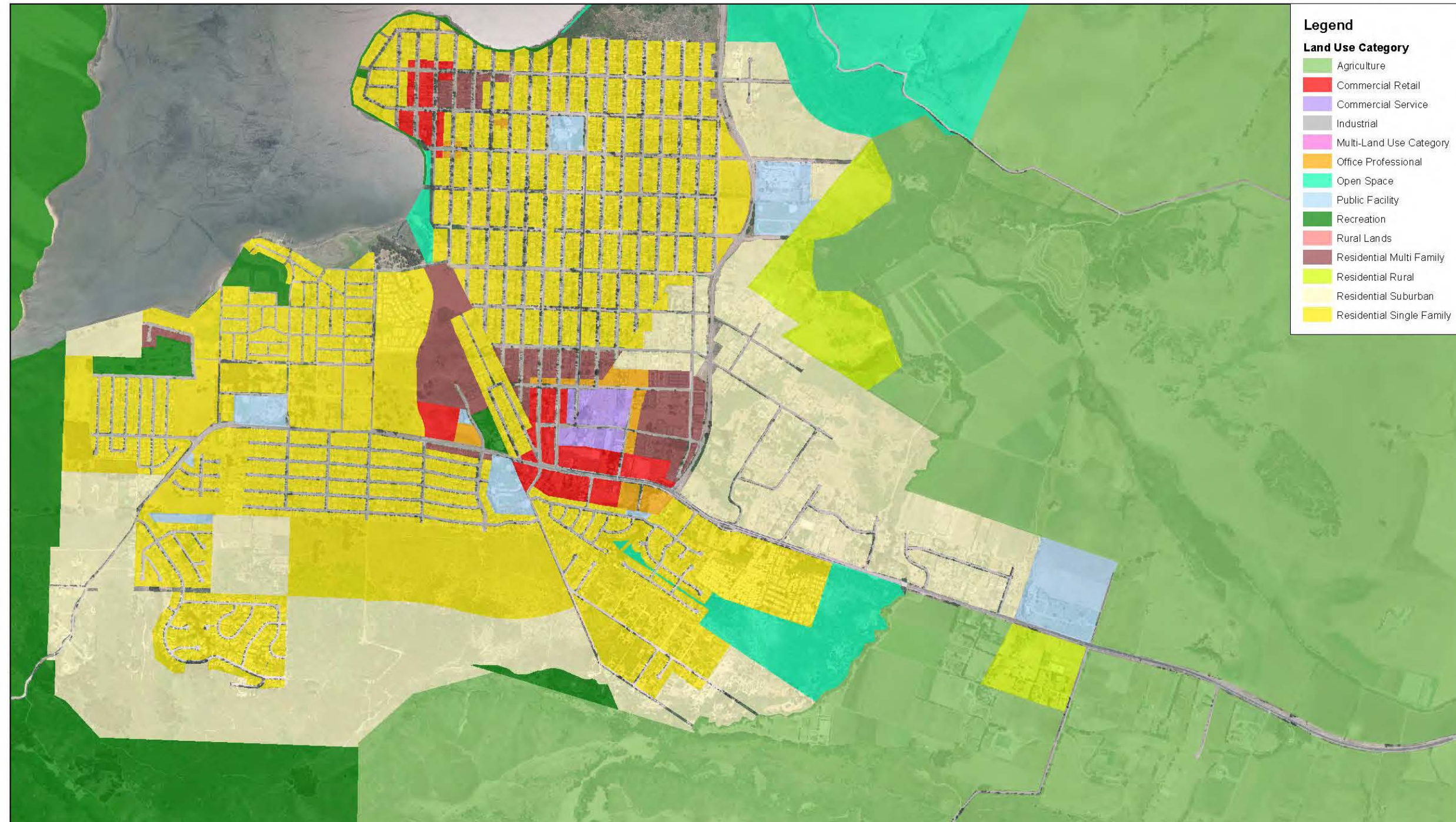

Source: 2007 Digital Globe aeriels, San Luis Obispo County GIS Data

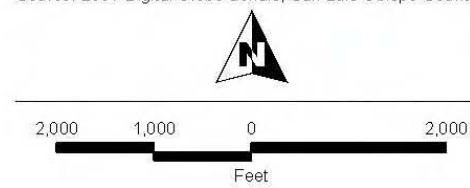

Los Osos Area Land Use

COUNTY OF SAN LUIS OBISPO • LOS OSOS WASTEWATER PROJECT

Figure 2.3 Los Osos Water Purveyors, Urban Services Line, and Prohibition Zone

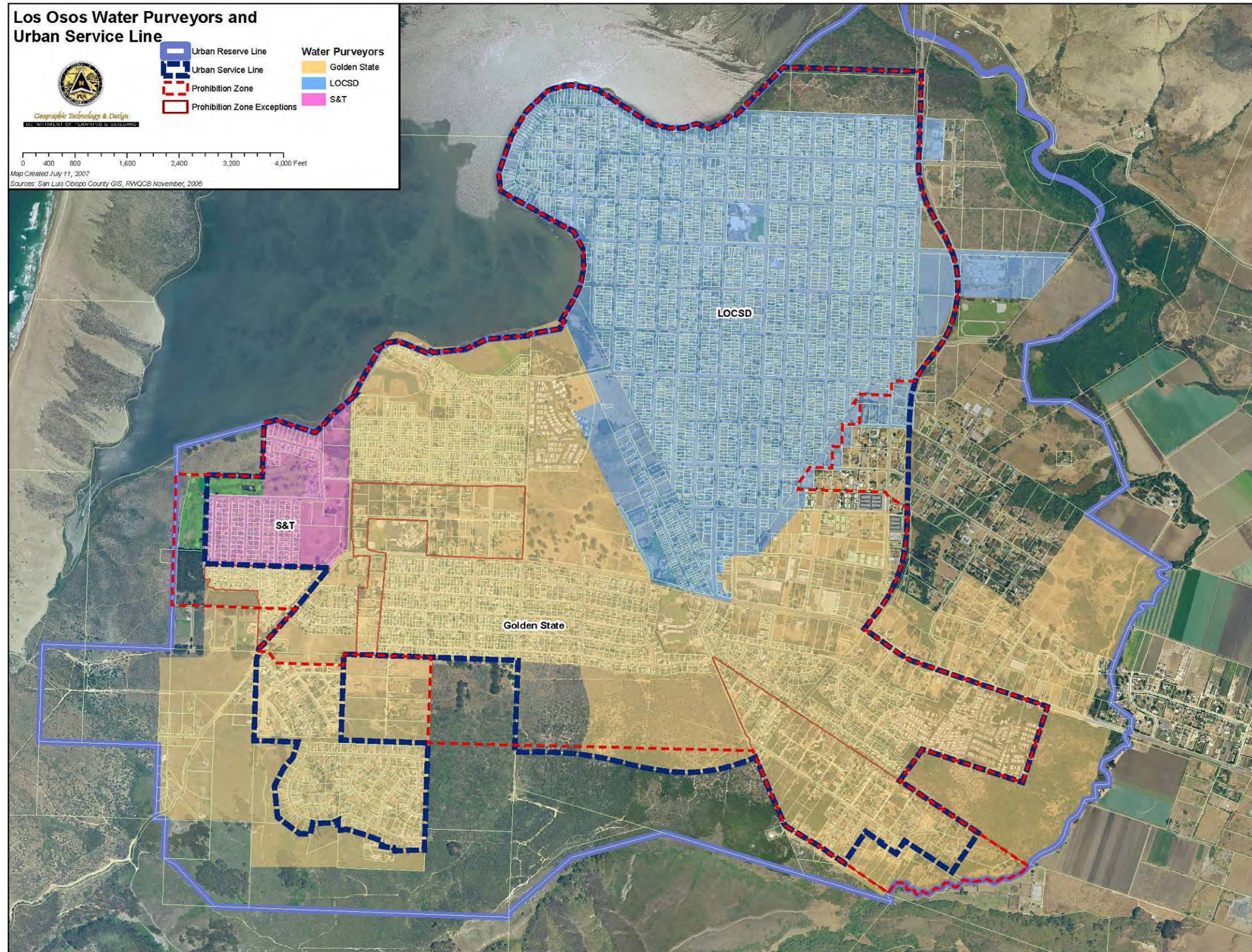

### 2.3. ENVIRONMENTAL RESOURCES PRESENT

An EIR has been prepared for the project in accordance with the California Environmental Quality Act (CEQA) which evaluates the potential environmental impacts associated with a wastewater collection, treatment, and disposal system for the community of Los Osos. The County of San Luis Obispo, as the lead agency for the EIR, certified it on September 29, 2009. An Environmental Assessment in accordance with the National Environmental Policy Act (NEPA) has also been prepared. CEQA requires that all state and local government agencies consider the environmental consequences of projects over which they have discretionary authority before taking action. The EIR is unique in that it examines a range of alternatives on a co-equal basis in order to maximize flexibility during project selection.

The EIR is intended to serve as an informational document for the public agency decision-makers and the public regarding the objectives, impacts, and components of the proposed project. The document addresses the potential significant adverse environmental impact that may be associated with this project, as well as identifies appropriate feasible mitigation measures and design features that may be adopted to reduce or eliminate these impacts. It identifies environmental sensitivities in the project study area, and it establishes mitigation measures and guidelines to address project-level environmental impacts that may result from specific project implementation for construction and operational consideration. The EIR evaluates the direct, indirect, and cumulative impacts of the proposed project, as well as project alternatives in accordance with the provisions set forth in CEQA and the CEQA Guidelines.

The EIR contains numerous subsections describing potential impacts of the proposed project alternatives analyzed for the project. These subsections include:

- Land Use and Planning
- Groundwater Quality and Water Supply
- Drainage and Surface Water Quality
- Geology
- Biological Resources
- Cultural Resources
- Public Health and Safety
- Traffic and Circulation
- Air Quality (and Greenhouse Gasses)
- Noise
- Agricultural Resources
- Visual Resources
- Environmental Justice

Appendix K of the EIR includes an extensive analysis of climate change impacts through the estimation and review of potential greenhouse gas emissions. The EIR concludes that in the context of overall community carbon footprint, the available collection, treatment, and disposal alternatives are relatively close from the perspective of climate change impact.

Figure 2.4 Environmental Setting

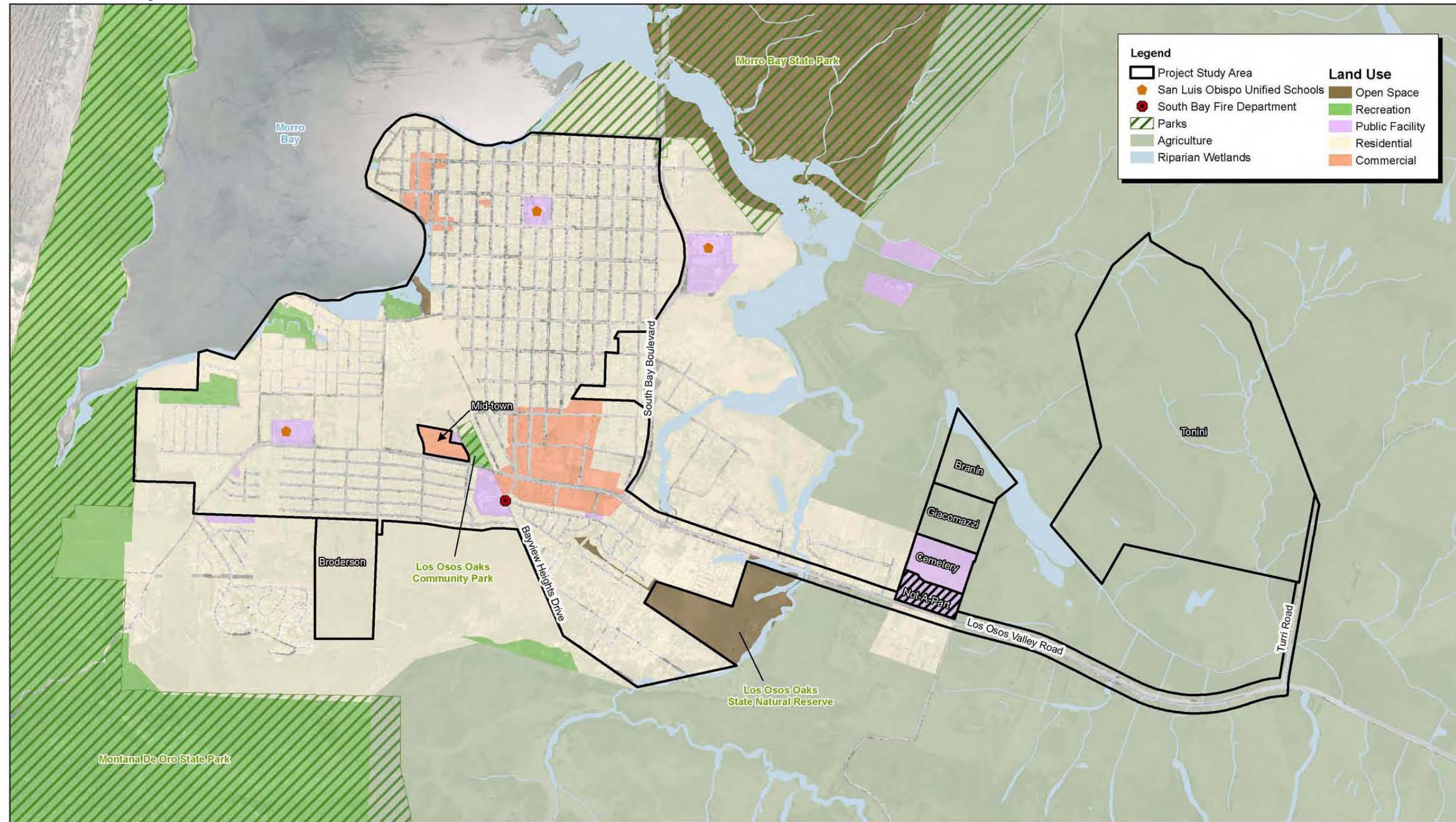

Source: AirPhoto USA, San Luis Obispo County GIS Data, and MBA GIS Data.

Michael Brandman Associates  
 02240002 • 11/2008 | 4-1\_environmental\_setting.mxd

Exhibit 4-1  
Environmental Setting Map

COUNTY OF SAN LUIS OBISPO • LOS OSOS WASTEWATER PROJECT  
ENVIRONMENTAL IMPACT REPORT

Figure 2.5 Special Status Species Habitat

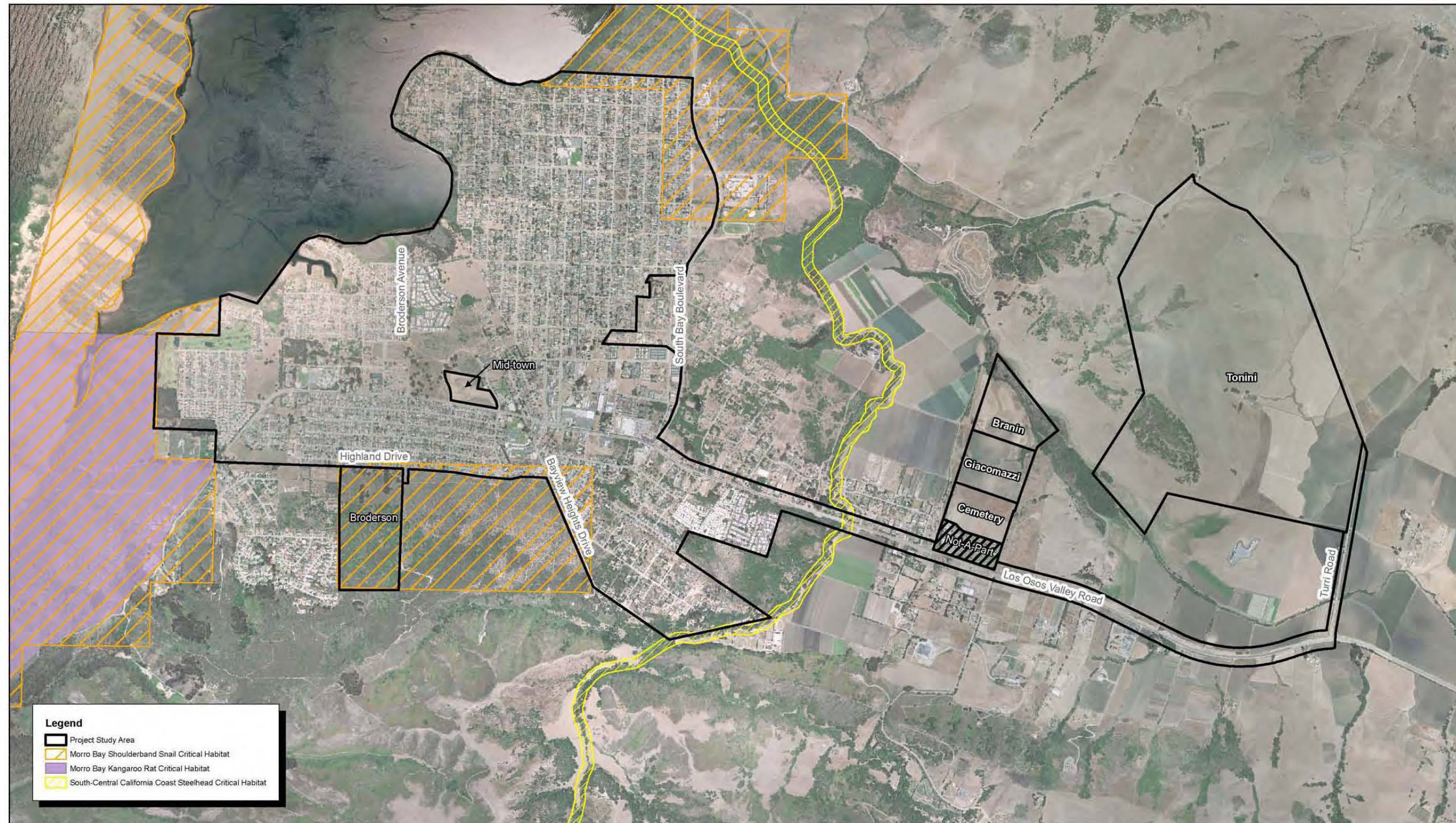

Source: AirPhoto USA and San Luis Obispo County GIS.

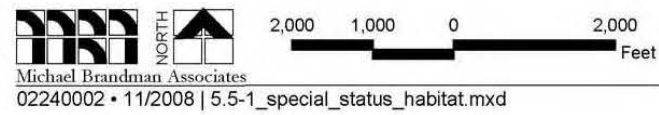

Exhibit 5.5-1  
Special Status Species Habitat

COUNTY OF SAN LUIS OBISPO • LOS OSOS WASTEWATER PROJECT  
ENVIRONMENTAL IMPACT REPORT

Figure 2.6 Jurisdictional Waters and Wetlands



Source: AirPhoto USA and San Luis Obispo County GIS.

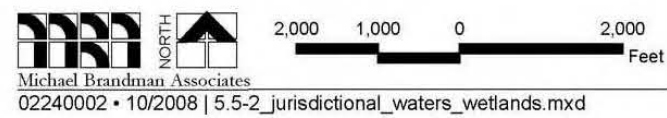
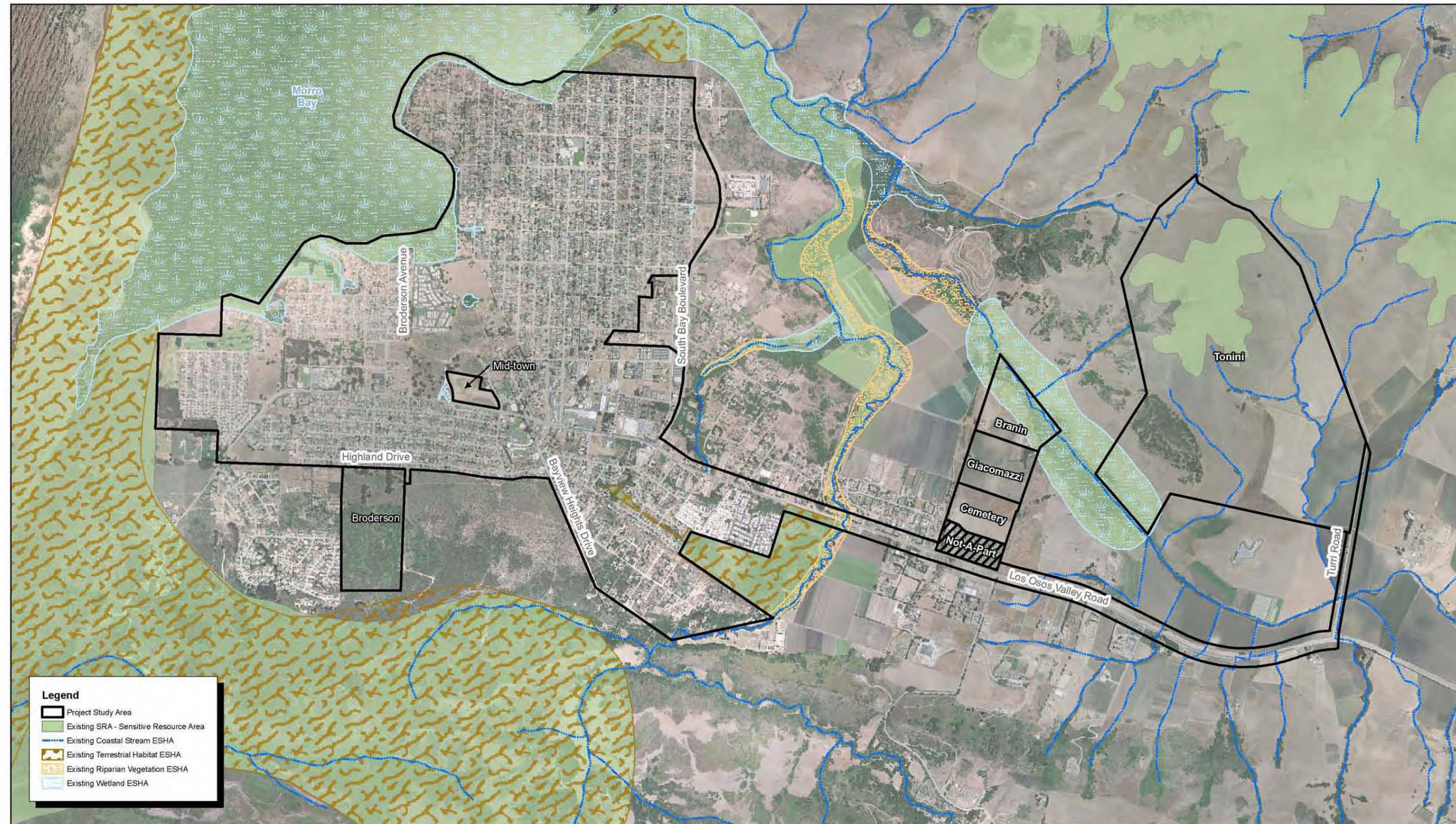

Exhibit 5.5-2  
 Jurisdictional Waters and Wetlands

COUNTY OF SAN LUIS OBISPO • LOS OSOS WASTEWATER PROJECT  
 ENVIRONMENTAL IMPACT REPORT



Figure 2.7 SRA and ESHA Lands



Source: AirPhoto USA and San Luis Obispo County GIS.

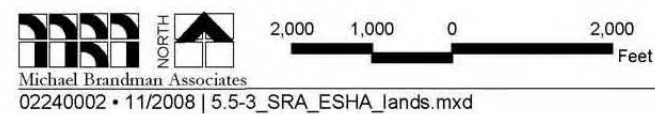
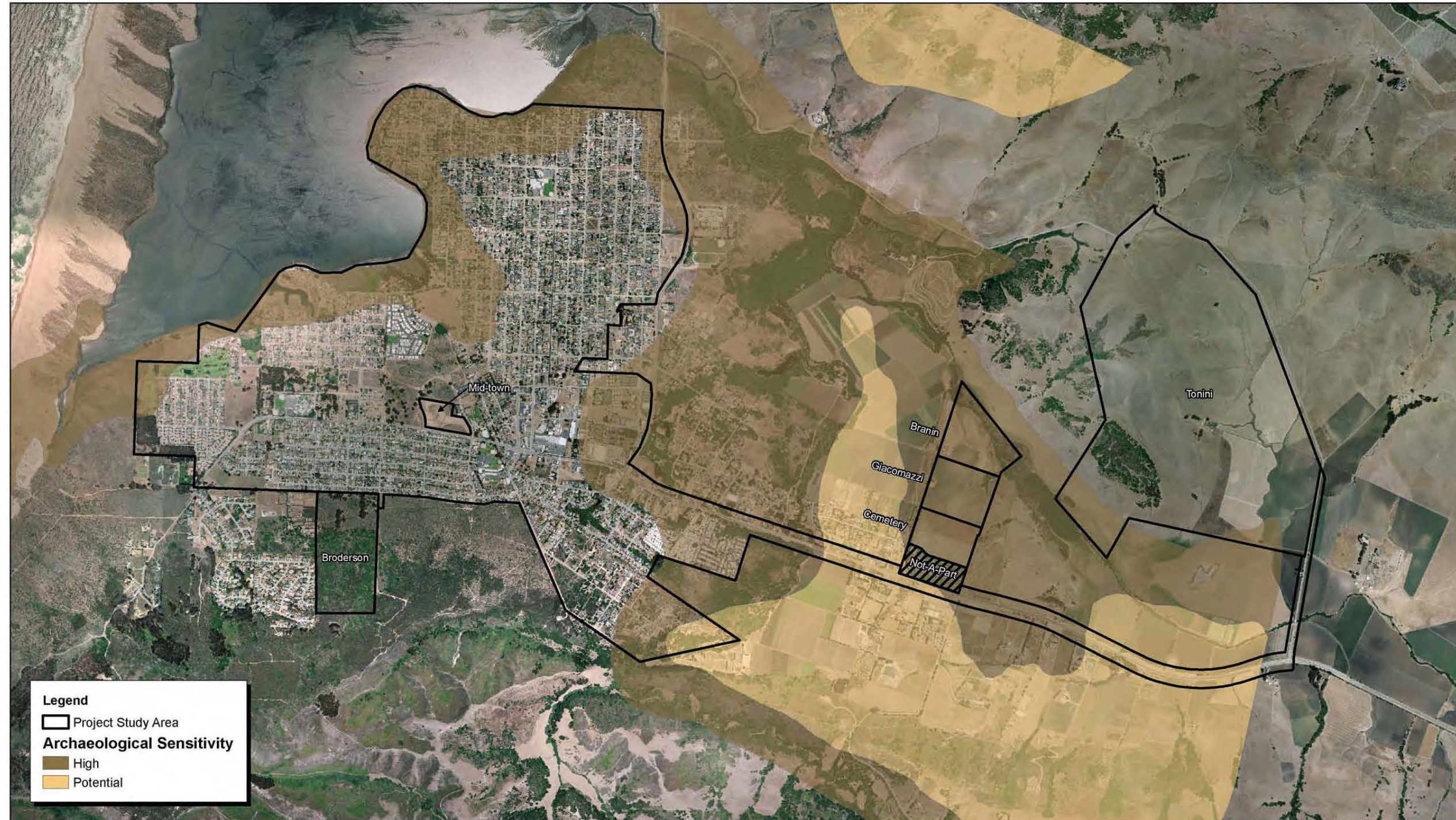



Exhibit 5.5-3  
 SRA and ESHA Lands

COUNTY OF SAN LUIS OBISPO • LOS OSOS WASTEWATER PROJECT  
 ENVIRONMENTAL IMPACT REPORT

Figure 2.8 Archaeological Sensitive Areas



Source: AirPhoto USA, San Luis Obispo County GIS Data, Far Western GIS Data, and MBA GIS Data.

 **NORTH**  
2,000 1,000 0 2,000 Feet  
Michael Brandman Associates  
02240002 • 11/2008 | 5.6-1\_archaeo\_sensitive\_areas.mxd

**Exhibit 5.6-1**  
**Archaeological Sensitive Areas**

COUNTY OF SAN LUIS OBISPO • LOS OSOS WASTEWATER PROJECT  
ENVIRONMENTAL IMPACT REPORT

Figure 2.9 Agricultural Soils and Williamson Act Status

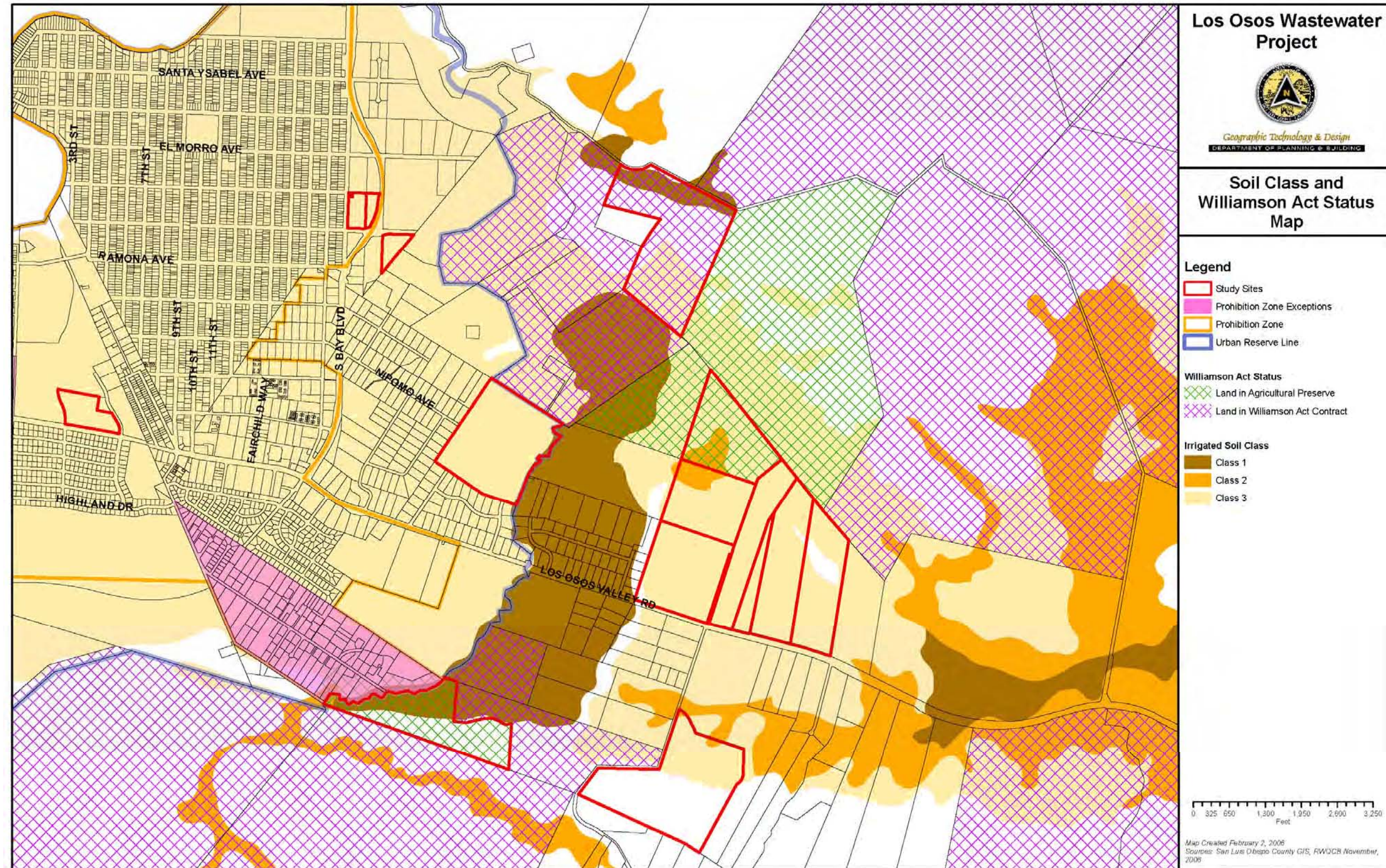

2.4. GROWTH AREAS AND POPULATION TRENDS

The current population of the community of Los Osos is approximately 14,200 residents, of which approximately 12,500 reside within the proposed wastewater project area. Since 1988, very little new housing has been constructed within the Prohibition Zone, and there is a backlog of construction demand in the community. The removal of the discharge moratorium within the Prohibition Zone will lead to a certain amount of new growth. However, not all of this development is expected to occur immediately. Although the discharge moratorium will be removed after completion of the project, further development in the Prohibition Zone will be subject to numerous other regulatory requirements such as compliance with Coastal Development Permit conditions which call for addressing water supply and endangered species habitat issues prior to connection to the wastewater project.

As shown in Table 2.1, the growth that has occurred within Los Osos between Year 1990 and Year 2000 includes an increase in 117 residential units, but a decrease in population of 223 people. Table 2.1 also includes an estimate of the build-out population for the community.

<b>Table 2.1: Year 1990, Year 2000, and Build-out Population and Housing Data for Community of Los Osos</b>			
<b>Community of Los Osos</b>	<b>Year 1990 <sup>1</sup></b>	<b>Year 2000 <sup>1</sup></b>	<b>Estimated Build-out</b>
Population	14,377	14,154	19,713
Housing	6,094	6,214	8,284

<sup>1</sup> Draft Environmental Impact Report for the Los Osos Community Services District, Wastewater Facilities Project, Page 61, November 2000

The proposed project will provide a new wastewater system that will allow infill housing and population growth within the Prohibition Zone. This increase in housing and population would occur on currently vacant or underdeveloped lots scattered throughout the community. Many of these lots are currently served by roads which contain utilities within the rights-of-way that can serve additional development.

Land use and zoning in Los Osos is regulated by the County of San Luis Obispo, primarily through a General Plan document entitled the Estero Area Plan. The portions of the Estero Area Plan that impact Los Osos will be updated following the implementation of the proposed wastewater project. The current Estero Area Plan projects the ultimate population of the Los Osos community to be over 28,000 residents. However, many of the properties historically slated for development have been acquired for permanent open space and create a “green-belt” around Los Osos. More current estimates compiled by the County as part of the Estero Area Plan update process projected the build-out population at 19,713 (2004 draft). Estimates of the future population within the prohibition zone vary by source, but generally fall in the range of 17,800 (SLO County Planning) to 18,428 (Wastewater Project Team). For the purpose of the wastewater project, the more conservative build-out population of 18,428 was utilized for the collected area. See Section 4.c for discussion of growth capacity of the wastewater system.

2.5. ECONOMIC DEMOGRAPHICS

The community of Los Osos is a predominantly residential community of 14,251 residents (U.S. Census 2000) located along the central Coast of California on the southern edge of Morro Bay in San Luis Obispo County. It is combined with Baywood Park to form the Census designated place of Baywood-Los Osos. There is a small business district concentrated over just a few blocks along Los Osos Valley Road on the southeast side of the town, with several additional shops servicing the Baywood section of Los Osos. The remaining sections of town are almost entirely residential. There is no heavy or light industry within Los Osos.

Employment status for the active members of the labor force is provided in Table 2.2. In Year 1999, there were 11,538 residents aged 16 years or older; 7,250 (68%) of which were active within the labor force.

Table 2.3 provides statistical data on Year 1999 income per household within the community of Los Osos. Median household income is shown as **\$46,558**. A total of 190 families and 1,205 individuals were living below the poverty level in Year 1999.

**Table 2.2 Employment Status – Los Osos, CA<sup>1</sup>**

Occupation	Number	Percent
Management, professional, and related occupations	2,660	38.4
Service Occupations	1,258	18.2
Sales and office occupations	1,657	23.9
Farming, fishing, and forestry occupations	73	1.1
Construction, extraction, and maintenance occupations	654	9.4
Production, transportation, and material moving occupations	629	9.1
Armed Forces	28	0.2
Unemployed	291	2.5
<b>Total</b>	<b>7,250</b>	<b>68</b>
<sup>1</sup> U.S. Bureau of the Census, Census 2000		

**Table 2.3 Household Income – Los Osos, CA<sup>1</sup>**

Income Range	Number	Percent
Households	5,908	100
Less than \$10,000	296	5.0
\$10,000 to \$14,999	322	5.5
\$15,000 to \$24,999	793	13.4
\$25,000 to \$34,999	791	13.4
\$35,000 to \$49,999	914	15.5
\$50,000 to \$74,999	1,269	21.5
\$75,000 to \$99,999	792	13.4
\$100,000 to \$149,000	484	8.2
\$150,000 to \$199,999	100	1.7
\$200,000 or more	147	2.5
<b>Median Household Income</b>	<b>\$46,558</b>	<b>--</b>
<sup>1</sup> U.S. Bureau of the Census, Census 2000		

Figure 2.10 Population and Median Household Income

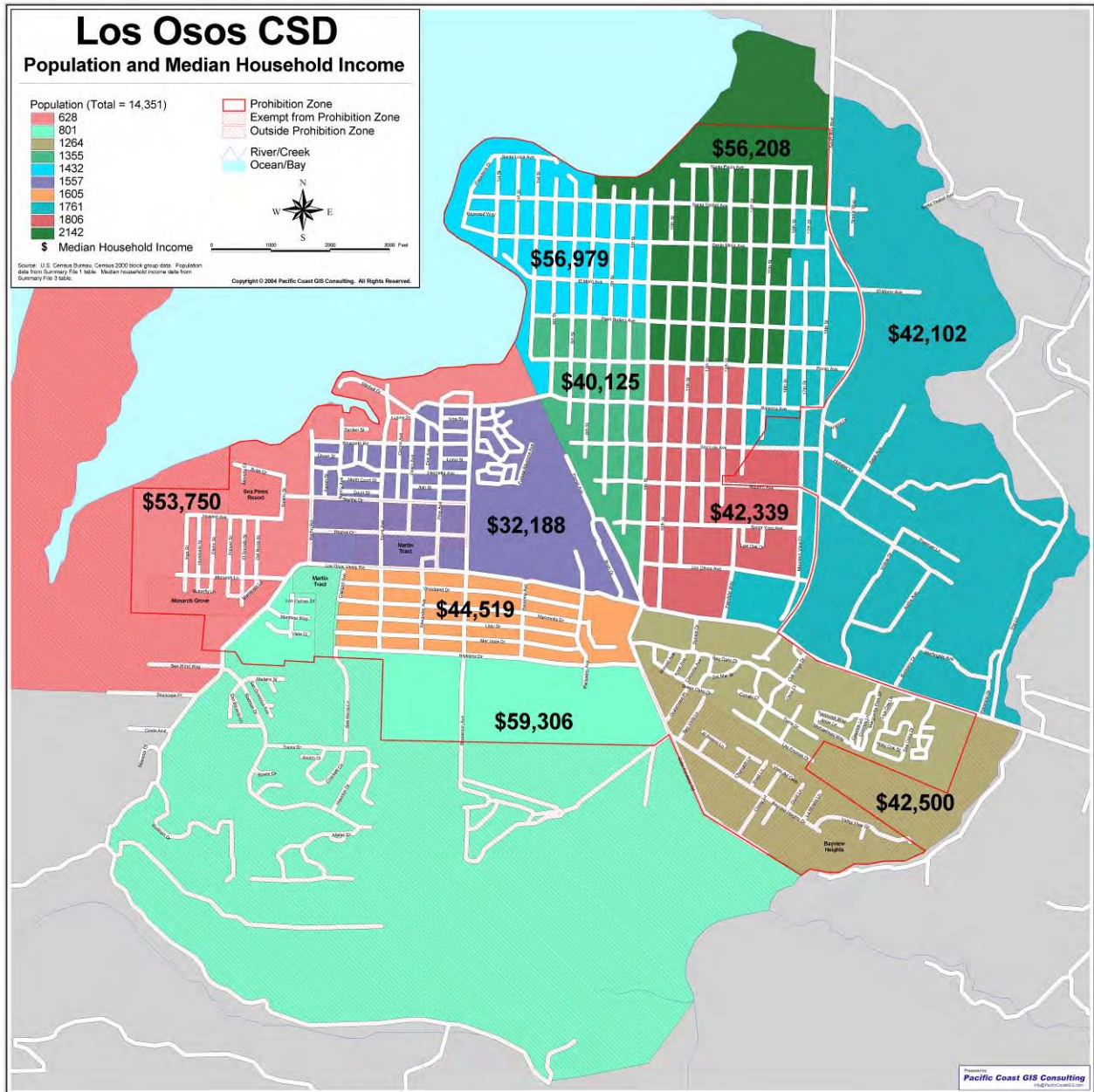

### CHAPTER 3: EXISTING FACILITIES

A number of small neighborhood septic systems, and one decentralized tertiary reclamation facility, currently exist in Los Osos. These facilities are described below:

- Four mobile home parks exist within the proposed collection area, each of which has neighborhood septic systems, including laterals to each unit and collector sewers within each park. The mobile home parks will be connected to the project and the septic system abandoned.
- The subdivision of Vista De Oro includes 73 single family lots that are connected to a gravity sewer system, followed by a neighborhood septic system. This subdivision will be connected to the project and the septic system abandoned.
- The subdivision of Bayridge Estates includes 147 single family lots that are connected to a gravity sewer system, followed by a neighborhood septic system. This subdivision will be connected to the project and the septic tanks abandoned. The existing leachfields will be used to discharge recycled water from the project.
- The subdivision of Monarch Grove includes 83 single family lots that are connected to a tertiary wastewater treatment facility, which is regulated under adopted wastewater discharge requirements. The Sea Pines golf resort is also served by this decentralized facility. The current project does not include a connection to Monarch Grove and Sea Pines.

In addition to the above facilities, approximately 3,000 linear feet of gravity sewer pipeline was installed in 2005 prior to the cessation of construction activities on the Los Osos Community Services District project. These installed facilities are consistent with the planned gravity sewer system contemplated in this report.

a. Location Map. See Figure 3-1.

b. History. There are no existing sewage facilities in Los Osos, beyond the few thousand feet of gravity sewer collectors. All facilities associated with this project will be new construction.

c. Condition of Facilities. The existing gravity sewer collectors are expected to be in acceptable condition for continued use as part of the wastewater project. However, they will be inspected during the construction phase of the project and any necessary repairs will be made prior to connection to the project.

d. Financial Status of any Existing Facilities. The existing facilities are owned the by Los Osos CSD and will be transferred to the County for use in the project according to the transfer provisions authorized in AB 2701.

Figure 3.1 Location of Existing Neighborhood Septic and Sewer Systems

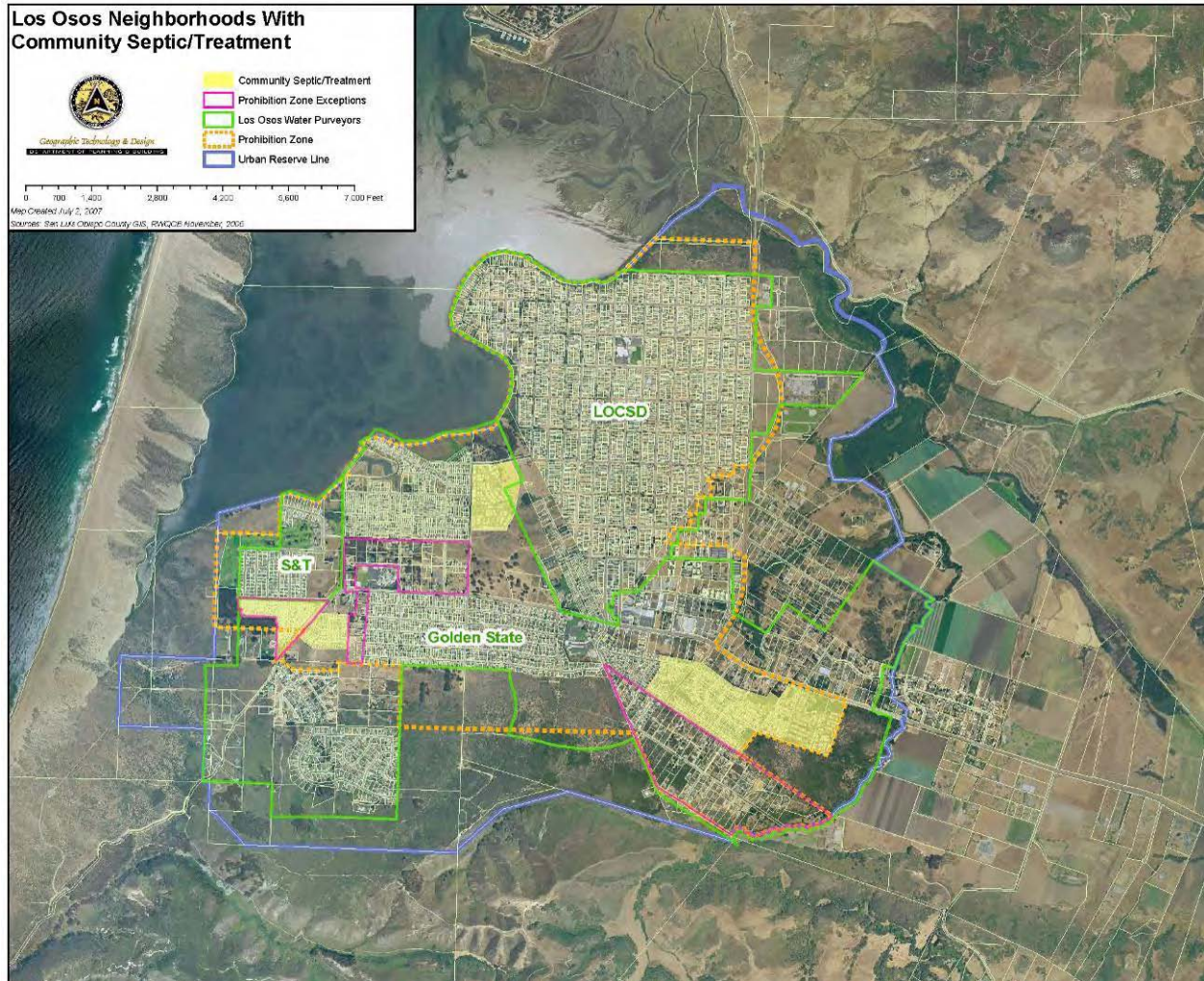



## CHAPTER 4: NEED FOR PROJECT

### 4.1. INTRODUCTION

Beginning as early as 1971, the RWQCB and other health agencies became concerned with the safety of the Los Osos community sanitary system. Concern arose from the high level of variance in depth to the ground water, which in certain areas is shallow enough to flood leach fields during wet weather. Additionally, many of the smaller lots do not contain sufficient land area to accommodate leach fields. As a result, these areas depend solely on deeper seepage pits which may discharge directly into the ground water. To compound matters, the Los Osos area draws its potable water supply from the groundwater. The RWQCB responded in June, 1971, by adopting an interim Basin Plan which contained a provision prohibiting septic system discharge in the area after 1974.

In 1983 the RWQCB determined that contamination in excess of State standards had occurred in the groundwater basin (upper aquifer) with a substantial effect from the use of septic systems throughout the community and followed with a regulatory mandate to cease and desist.

The RWQCB issued Resolution No. 83-13 and made the following findings:

- Previous studies (Brown and Caldwell, 1983) indicated that the quality of water derived from the shallow aquifer underlying the community was deteriorating, particularly as it relates to increasing concentrations of nitrates in excess of State standards.
- The current method of wastewater disposal by individual septic tank systems located in areas of high groundwater are a major contributing factor to this degradation of water quality.
- Continuation of this method of waste disposal could result in health hazards to the community and the continued degradation of groundwater quality is in violation of the Porter-Cologne Act.

Further, the RWQCB resolution established discharge prohibitions for a portion of the Los Osos area that became known as the Prohibition Zone. The action set a deadline for 1988, beyond which most new septic system discharges from new construction or remodels were prohibited. These regulatory actions created a moratorium, effectively halting new construction or major expansions of existing development until the water pollution problem was solved.

The need and primary purpose of the project is development of infrastructure for a wastewater collection, treatment and disposal system to serve the community of Los Osos in the designated Prohibition Zone in order to comply with the RWQCB mandate. In addition to meeting the RWQCB regulatory requirements, the project will provide a number of water quality and water supply benefits.

- The primary benefit of the LOWWP is compliance with the Regional Water Quality Control Board directives to alleviate groundwater contamination, primarily nitrates, which have occurred at least partially because of the use of septic systems throughout the community of Los Osos.
- The LOWWP provides an opportunity to begin the process of mitigating seawater intrusion, reducing nitrate contamination, and setting long term goals for achieving a sustainable water supply.
- Developing a wastewater project in Los Osos will lead to the removal of the discharge moratorium instituted by the RWQCB, returning community growth and development decisions to local officials and allowing for local control of water resources.
- Alleviating groundwater contamination will provide an additional direct benefit to the Morro Bay National Estuary and State Marine Reserve located adjacent to the Los Osos community.
- Properly implemented future measures for effluent disposal will enhance opportunities for water purveyors to improve the local water resources.

The need for the project has never been more acute than the present time. Over 25 years and approximately \$50 million have been spent with no solution to the septic tank pollution. The current County efforts, authorized through unprecedented action by the state legislature, are likely the last chance for a locally led solution. The currently favorable bidding climate, availability of federal stimulus funding, and pending RWQCB fines are all factors that point to the need to implement this project within the next several months.

#### 4.2. HEALTH, SANITATION AND SECURITY

Nitrates are the primary constituent of concern in sewage. Excessive nitrate levels can lead to health problems in humans and can cause algal blooms in surface water, which consume large quantities of dissolved oxygen resulting in adverse impacts to aquatic life. Bacteria, such as fecal coliform, and viruses are additional constituents of concern as they pose potential health risks to humans both from direct contact with contaminants in the surface water and through the consumption of shellfish.

In 1995, a study issued in by the RWQCB titled “Assessment of Nitrate Contamination in Ground Water Basins of the Central Coast Region Preliminary Working Draft,” illustrated significant increases in nitrate concentrations over time in both the lower and upper aquifers. According to a letter from the RWQCB on July 10, 1998, 107 monitoring wells with more than 1,100 data points were used in the construction of the contour maps included in the study. The RWQCB letter stated:

*Monitoring data indicates much of the shallow groundwater in the most densely developed areas exceeds 45mg/l, the drinking water standard for nitrate. For this reason, many of the shallow water supply wells have been removed from service and demand shifted to the deeper aquifer. Dependence upon the deeper aquifer exacerbates the surface water problems because the community's water supply, formerly from the upper aquifer, is now drawn from the deeper aquifer and recharged (after use) to the upper aquifer causing ground water levels to rise and flood more septic systems. Increasing surface water impacts including: restriction of portions of shellfish harvesting areas because of rising bacteria levels: water surround the Los Osos area periodically do not meet bacteria standards for water contact recreation (such as swimming, wading, kayaking and small boat sailing): and the public is increasingly exposed to surface wastewater.*

#### 4.3. SYSTEM OPERATIONS AND MAINTENANCE

Existing system O&M considerations are not a factor in determining the need for the project, as there are no existing sewage facilities in Los Osos, beyond the few thousand feet of gravity sewer collectors. All facilities associated with this project will be new construction.

#### 4.4. GROWTH/BUILD-OUT FLOWS AND LOADS PROJECTIONS

Estimates of the projected wastewater flows and loads for this project were presented in the Rough Screening Report and Fine Screening Report. The Fine Screening Report recommended an I/I allowance of 0.3 million gallons per day (mgd) additional flow for the average monthly wet weather flow for a gravity system. I/I estimates for the collection system are the main source of uncertainty in calculating the future treatment facility influent volume. Updates to the I/I estimates were included in the Flows and Loads Technical Memorandum (Carollo Engineers, 2008) which resulted in a reduction of PHWWF to 2.5 mgd for a gravity system. The full text of the final Flows and Loads Technical Memorandum is included in the Appendices.

There is some uncertainty in the anticipated per capita wastewater flows in the Prohibition Zone. Wastewater from the Prohibition Zone is currently discharged onsite from septic tanks at each home. Therefore, the volume and quality cannot be directly measured. Instead, dry weather wastewater flows were estimated based on wintertime water use. This assumes that limited exterior occurs during the wintertime. According to the Flows and Loads TM and the Rough Screening Analysis, the 2006 water consumption rates for the approximately 8,500 residents served by the LOCSO were about 66 gallons per capita per day. Assuming minimal exterior water use, 66 gallons per capita per day is a reasonable current estimate of the Los Osos per capita wastewater flow. Because Los Osos is not a vacation community and because there is no seasonal industry, this figure is expected to be fairly constant throughout the year. With the estimated build-out population of 18,428, this yields a baseline dry-weather wastewater generation rate of 1.2 mgd.

As a condition of approval in the Coastal Development Permit, the project will also implement a water conservation program with a goal of reducing indoor water consumption to 50 gallons per capita per day, which is more than a 25% reduction over current use estimates. The conservation

program will be accomplished through subsidized, mandatory residential and commercial fixture retrofits, appliance rebates, education, and water efficiency audits. Ongoing monitoring and public outreach programs will be adopted to ensure that the water conservation goals are maintained. Based on this conservation level, the dry weather flow value is expected to drop below 1.0 mgd at build-out. However, to be conservative, the project will be designed for the base flow rate of 1.2 mgd and assume a more moderate conservation level of 0.1 mgd.

A summary of flow estimates are presented in the table below. These are conservative flow estimates provided for treatment facility sizing. Estimates were calculated based on assumptions derived from varying literature data and previous experience with I/I as well as information specific to the current water use in Los Osos (see Final Flows and Loads Technical Memorandum, November 2008, for additional detail). Average daily flow, even during periods of sustained high groundwater, is expected to be substantially less than 120 gallons per capita per day as indicated. As a result, excessive I/I is not anticipated in accordance with SRF guideline IX.A.5. The final peak daily flow (ADWWF) for process design is assumed to be 1.4 mgd.

<b>Table 4.1: Projected Wastewater Generation Rates</b>				
<b>Wastewater Generation Estimate (mgd)<sup>1</sup></b>	<b>Conservation (mgd)</b>	<b>I/I<sub>average</sub> (mgd)</b>	<b>ADWWF<sup>2</sup> (mgd)</b>	<b>PHWWF<sup>3</sup> (mgd)</b>
1.2	0.1 - 0.3	0.3	1.4	2.5
<sup>1</sup> Based on Buildout Population of 18,500 people and 66 gallons per capita per day wastewater generation rate. <sup>2</sup> ADWWF = Average Day Wet Weather Flow = Wastewater Generation Estimate - Conservation + I/I <sub>average</sub> . ADWWF serves as a basis for sizing wastewater collection and treatment facilities. <sup>3</sup> PHWWF = Peak Hour Wet Weather Flow				

The Rough Screening Report listed influent concentrations from a gravity collection system for the future wastewater treatment facility. These values are considered valid and will be used for treatment facilities sizing for a gravity collection system. They are shown in the table below.

<b>Table 4.2: Gravity Collection System Wastewater Characteristics</b>			
<b>Gravity Collection System</b>	<b>BOD5<sup>1</sup> (mg/l)</b>	<b>SS<sup>1</sup> (mg/l)</b>	<b>total - N<sup>1</sup> (mg/l)</b>
Average Day	340	390	56
Peak Day	350	400	58
<sup>1</sup> BOD5 = 5 Day Biological Oxygen Demand    SS = suspended solids    N = Nitrogen			

## CHAPTER 5: ALTERNATIVES CONSIDERED

### 5.1. INTRODUCTION

Project alternatives have received extensive analysis in previous and current efforts to complete a wastewater project in Los Osos. The County's current efforts under AB 2701 started with a broad range of alternatives. The alternatives were narrowed through the engineering screening process with the Rough Screening and Fine Screening Reports. These reports maintained the widest possible range of alternatives, while eliminating those that were non-viable or redundant. The primary engineering and cost alternatives analysis was completed in the Fine Screening Report with in subsequent public discussions through the Technical Advisory Committee. Capital costs were developed in April, 2007 dollars (ENR Index 7879) with inflation factors and associated project soft costs included in the final calculations. A series of 12 technical memoranda were also used to evaluate various alternatives in more detail and support the EIR development. Finally, the selection of an alternative for each of the project components is a result of the environmental process and the co-equal analysis in the project EIR. The EIR analyzed several alternatives on a co-equal basis and identified the environmentally superior project. Then, through the formal decision making process at the County Planning Commission and Board of Supervisors, the environmental, economic and social factors were all considered together to reach a final approved project description.

### 5.2. APPROACH TO ALTERNATIVES ANALYSIS

The primary goal of the project is to construct and operate a community wastewater collection, treatment, and disposal system and thereby comply with the RWQCB's Resolution 83-13. Eliminating discharges from onsite septic systems, as directed by the RWQCB, will also help accomplish the project's second primary goal: alleviating groundwater contamination, primarily nitrate contamination that has occurred at least partially because of the use of septic systems throughout the community.

The sustainability of water resources is also an important issue because of seawater intrusion that is contaminating the lower aquifer of the Los Osos groundwater basin. While the focus of the project is to solve the wastewater problem, and thereby alleviate groundwater contamination, the wastewater project also creates opportunities for the water purveyors to improve the local water resources.

#### Screening Analysis

When the County assumed responsibility for the project in January, 2007, it had already embarked on an alternatives review process based on policies established by the County Board of Supervisors in June 2006. The Project Team began by preparing the "Potential Viable Project Alternatives Rough Screening Analysis Report" (Carollo Engineers, March, 2007). The Rough Screening Report focused on potential alternatives for each component of the wastewater project. The project components included the collection system, treatment technologies, treatment facility sites, effluent reuse and disposal, and solids treatment and disposal. The Rough Screening Report categorized alternatives as being infeasible or potentially viable.

The project component alternatives that passed through the rough screening analysis were screened further detail, including developing cost estimates, in the “Potential Viable Project Alternatives Fine Screening Analysis Report” (Carollo Engineers, August, 2007).

A key issue addressed in the Fine Screening Report was the relationship between the wastewater project and water supply benefits. All of the potable water for the community is obtained from its underlying groundwater basin. The basin consists, generally, of an unconfined, upper aquifer, which is contaminated with high nitrate levels at least partially because of the use of septic systems, and a confined, lower aquifer which is being impacted to seawater intrusion as a result of over pumping. The seawater intrusion has progressed to the central area of the community and required the shut-down of several production wells. On March, 27, 2007, the San Luis Obispo County Board of Supervisors certified a Level of Severity III for Los Osos, the highest water resource problem level in the County’s Resource Management System (RMS).

The Fine Screening Report recognizes that the wastewater project has the ability to provide important water supply benefits and to help mitigate seawater intrusion. By replacing the existing septic tanks, the project will address the nitrate contamination and be a critical factor in increasing the supply from the upper aquifer. The effluent reuse and disposal alternatives also have the opportunity to mitigate seawater intrusion in the lower aquifer. The report analyzed and categorized project alternatives based on their respective level of seawater intrusion mitigation, while considering capital costs and the feasibility of implementation.

Three other important considerations in the Fine Screening Report were sustainability, future adaptability and project costs. Sustainability, a stated goal for the Los Osos community, is defined in the Fine Screening Report as minimizing the project’s energy consumption and reusing the treated wastewater effluent as a resource to benefit the community. To the extent possible, project facility alternatives that provide flexibility to meet future regulatory requirements or provide capacity to serve the build-out population were preferred. To evaluate project costs, the engineering consultant developed conceptual-level capital and maintenance cost estimates and identified the apparent low cost alternatives.

The potential project components which passed the fine screening process, meeting the goals of the project at the lowest life-cycle costs, were combined into complete projects, known as “Viable Project Alternatives” (VPA). Each VPA was one that is considered permissible, constructible, and fundable. They included all of the project components, including collection system, wastewater treatment facility, treatment plant site, effluent reuse/disposal system, and solids processing and disposal system.

#### Technical Advisory Committee

In March, 2007 the San Luis Obispo County Board of Supervisors appointed fourteen local experts and laypersons to the Los Osos Wastewater Project Technical Advisory Committee (TAC). The TAC was divided into three sub-committees by the following disciplines: engineering/water resources, finance, and environmental. The TAC’s first priority was to

provide an evaluation of the Pros and Cons of the “Viable Project Alternatives.” They began by agreeing upon five core values and the major criteria for each.

<b>Table 5.1: Los Osos Wastewater Project Core Community Values</b>	
<b>Core Values</b>	<b>Major Criteria</b>
Affordability	<ul style="list-style-type: none"> <li>• Capital and construction cost</li> <li>• O&amp;M costs</li> <li>• Financing factors</li> <li>• Grant eligibility</li> <li>• Engineering and project management costs</li> </ul>
Environmental Stewardship	<ul style="list-style-type: none"> <li>• Environmental impacts</li> <li>• Potential risks due to system failure</li> <li>• Carbon footprint</li> </ul>
Flexibility	<ul style="list-style-type: none"> <li>• Flexibility to meet future needs and opportunities, including: expansion, future higher regulations, regional opportunities, etc.</li> <li>• Potential alternative energy opportunities</li> </ul>
Sustainability	<ul style="list-style-type: none"> <li>• Restoring and protecting our groundwater resources</li> <li>• Mitigating seawater intrusion and achieving groundwater balance in the basin</li> <li>• Minimizing energy use</li> <li>• Minimizing sludge production</li> </ul>
Community	<ul style="list-style-type: none"> <li>• Impacts on individual homeowners, residents, and businesses</li> <li>• Stakeholder support</li> <li>• Community acceptance</li> </ul>
Controllability	<ul style="list-style-type: none"> <li>• Risk of third party decisions, policies</li> <li>• Financial risks associated with wastewater projects</li> <li>• Design for maximum system control</li> </ul>
Source: Los Osos Wastewater Project Technical Advisory Committee, San Luis Obispo County Department of Public Works, Pro/Con Analysis on Project Component Alternatives, August 2007.	

Basing their analysis of the draft Fine Screening Report, their own experience, and public comments received in writing and at the open public meetings, the TAC prepared a report entitled “Pro/Con Analysis on Project Component Alternatives” (LOWWP Technical Advisory Committee, August 2007). The TAC’s detailed comments were carried forward into the screening process used to identify the project alternatives detailed in the Draft Environmental Impact Report (DEIR) prepared for the project (Michael Brandman Associates, November 2008). During 2008, a series of preliminary engineering Technical Memoranda were prepared

by the County's engineering consultants to support the environmental analysis. The TAC reviewed each of these in a public forum, receiving public input, and providing formal comments.

### Engineering Technical Memoranda

In early 2008, the County engineering consultant developed a series of twelve Technical Memoranda. These memoranda provided additional analysis of issues and alternatives that were identified in the screening process as need further study. They also supported the environmental analysis that was being conducted in parallel. The Technical Memoranda cover the following range of issues:

- Onsite Treatment
- Decentralized Treatment
- Low Pressure Collection System
- Flows and Loads
- Out-of-Town Conveyance
- Partially Mixed Facultative Pond Options
- Imported Water
- Solids Handling Options
- Effluent Reuse and Disposal Alternatives
- Septage Receiving Station Option
- Regional Treatment
- Greenhouse Gas Emissions Inventory

Each Technical Memorandum advanced the level of detail provided in previous documents. Draft memoranda were reviewed by the TAC and the public in community meetings, with formal comments received by the County. The environmental consultant also reviewed the draft memoranda and provided comments and questions. The final Technical Memoranda were revised in response to the comments received.

### Environmental Review

The County completed a co-equal environmental review process to meet the requirements of the California Environmental Quality Act (CEQA) and the National Environmental Policy Act (NEPA). The project draft EIR was released in November, 2008, and the final EIR was adopted by the County Board of Supervisors on September 29, 2009. The environmental documents evaluate the potential impacts associated with a range of alternatives for wastewater collection, treatment, and disposal systems for Los Osos. CEQA requires that all state and local government agencies consider the environmental consequences of projects over which they have discretionary authority before taking action. The project EIR is unique under CEQA in that it examines a range of alternatives on a co-equal basis in order to maximize flexibility during project selection.



An EIR is intended to serve as an informational document for the public agency decision-makers and the public regarding the objectives, impacts, and components of the proposed project. The document addresses the potential significant adverse environmental impacts that may be associated with this project, as well as identifies appropriate feasible mitigation measures and design features that may be adopted to reduce or eliminate these impacts. It identifies environmental sensitivities in the project study area and establishes mitigation measures and guidelines to address project-level environmental impacts that may result from construction and operation of the project.

The EIR for the Los Osos project contains numerous subsections describing potential impacts of the proposed project alternatives analyzed for the project. These subsections include:

- Land Use and Planning
- Groundwater Quality and Water Supply
- Drainage and Surface Water Quality
- Geology
- Biological Resources
- Cultural Resources
- Public Health and Safety
- Traffic and Circulation
- Air Quality (and Greenhouse Gasses)
- Noise
- Agricultural Resources
- Visual Resources
- Environmental Justice

Appendix K of the EIR also includes an extensive analysis of climate change impacts through the estimation and review of potential greenhouse gas emissions. The EIR concludes that in the context of overall community carbon footprint, the available collection, treatment, and disposal alternatives are relatively close from the perspective of climate change impact.

The EIR evaluation included the direct, indirect, and cumulative impacts of the proposed project, as well as project alternatives in accordance with the provisions set forth in CEQA and the CEQA Guidelines. It provided a comprehensive environmental document that allowed the County of San Luis Obispo to approve the environmentally superior alternative. The County certified a Final EIR based on the alternatives identified through this process and made findings that support the final project decision.

### 5.3. ALTERNATIVES DESCRIPTION

The project alternatives in the following components: collection system, treatment technologies, effluent reuse and disposal, solids treatment and disposal, and treatment facility sites.

#### a. Collection System.

The Rough and Fine Screening Reports, Technical Memoranda, and project EIR reviewed of a number of collection system technologies, including conventional gravity sewers, Septic Tank Effluent Pump/Septic Tank Effluent Gravity (STEP/STEG) collection, vacuum, and low pressure grinder pump systems.

Gravity: A conventional gravity system was designed and permitted as part of the previous LOCSD Project. The system is a mostly passive central sewer system that uses gravity to move waste to the treatment facility. Based on topography, it is necessary to utilize lift stations throughout the collection system. The system transports both liquids and solids to the treatment facility.

STEP/STEG: A STEP/STEG collection system retains the use of septic tanks. The septic tanks serve to settle solids and provide a primary level of treatment. The effluent from the tanks is conveyed to an in-street collection system via pumping (STEP system) or gravity (STEG system) through small diameter pipes. The in-street collection system also has relatively small diameter pipes because the waste stream is relatively free of solids. STEP/STEG wastewater lacks dissolved oxygen (anaerobic) compared to wastewater collected by other systems, which includes a small amount of dissolved oxygen (aerobic).

Vacuum: Vacuum sewer systems use an on-site vacuum valve pit package and then a pressure differential, instead of gravity, to move wastewater to a vacuum station and on to the treatment plant. Differential air pressure is used as the motive force to transport sewage. The main lines are under a vacuum of 16 to 20-inches mercury (-0.5 to -0.7 bar) created by vacuum pumps located at the vacuum station.

The vacuum system requires a normally closed vacuum/gravity interface valve at each entry point to seal the lines so that vacuum is maintained. The interface valves, located in a valve pit, open when a predetermined amount of sewage accumulates in the collecting sump. When the valve is opened, the pressure differential between atmospheric pressure and the vacuum in the mains provides the energy required to open the vacuum interface valves, evacuate the sump contents, and propel the sewage toward the vacuum station.

Low Pressure Grinder Pump: A low pressure collection system consists of individual sumps at each customer location that collect waste and contain a grinder pump. The low pressure system is also classified as a central sewer system. The waste is conveyed from the grinder pump sumps to an in-street collection system via pumping through small diameter pipes and on to the treatment plant. The in-street collection system also has relatively small diameter pipes because the solids in the waste stream have been broken down by the grinder pumps.

Combined Gravity, Vacuum and Low Pressure Collection System: The combined system consists of gravity, vacuum, and/or low pressure collection grinder pump systems depending on the localized topography throughout the system. The combined system allows for optimization of construction and operation and maintenance costs as compared to a dedicated system. The previous designed gravity system would serve as the starting point for this alternative. Vacuum and low pressure could be incorporated in locations where topography, groundwater, or other site-specific conditions dictate, based on a value-engineering process to reduce costs.

b. Treatment Process. The Rough and Fine Screening Reports, Technical Memoranda, and project EIR reviewed of a number of wastewater treatment management alternatives and treatment processes. The management alternatives included centralized, decentralized, onsite and regional treatment. The treatment processes evaluated include extended aeration/activated sludge, attached growth fixed media, and advanced treatment ponds.

(1) Centralized Treatment. The treatment process options considered for a centralized treatment facility included a broad range of potential process, divided into the three following categories.

- Extended Aeration/Activated Sludge
  - Extended Aeration Modified Ludzak-Ettinger (MLE)
  - Membrane Bio-reactor (MBR)
  - BIOLAC® Wastewater Treatment Process
  - Sequencing Batch Reactor (SBR)
  - Oxidation Ditch
- Attached-Growth Fixed Media
  - Trickling Filters
  - Rotating Biological Contactors (RBCs)
  - Packed-Bed Filters
- Advanced Wastewater Treatment Ponds
  - Advanced Integrated Wastewater Pond System (AIWPS)®
  - Facultative Ponds with Constructed Wetlands
  - Partially Mixed Facultative Ponds (e.g., Nelson Air Diffusion System (ADS)®, Advanced Integrated Pond System (AIPS)®)

**Extended Aeration/Activated Sludge**. These processes remove carbonaceous pollutants and convert ammonia in the raw wastewater to nitrate. The process typically operates without primary sedimentation, using raw wastewater as its source. This system is called “extended aeration” to distinguish it from the conventional activated sludge treatment process, which is usually preceded by primary sedimentation. If necessary for the selected disposal/reuse alternative, filtration (except for the MBR system) and disinfection would be required in addition to the extended aeration/activated sludge secondary treatment process to produce Title 22 unrestricted reuse tertiary recycled water.

- **Extended Aeration Modified Ludzak-Ettinger (MLE) Processes**. To meet nitrogen removal objectives of 7 to 10 mg/L required for most reuse/disposal alternatives, the extended aeration process must be modified by addition of anoxic tanks and internal recycle pumping. When modified in this way, this process is called the modified Ludzack-Ettinger (MLE) process, after its inventor. Extended aeration MLE has a proven history in wastewater treatment and is capable of meeting BOD,

suspended solids, and nitrogen water quality objectives. The extended aeration MLE process requires approximately 4 to 6 acres. The compact size of the system facilitates siting and minimizes land acquisition costs.

- Membrane Bio-Reactor (MBR). A membrane bio-reactor (MBR) system, was selected for the prior LOCSD Project treatment alternative due to the compact footprint. It is an activated sludge system similar to extended aeration MLE. However, polymeric membranes are used for separation of treatment organisms from the flow stream, instead of gravity sedimentation tanks. A membrane bio-reactor is used instead of secondary sedimentation tanks to remove the microorganisms from the flow stream. The membranes remove significantly more solids than sedimentation resulting in higher secondary effluent quality. Due to the high quality of the membrane effluent, only disinfection is required in addition to the MBR process to produce Title 22 unrestricted use recycled water. MBR facilities have a proven history in wastewater treatment and are capable of meeting BOD, suspended solids, nitrogen, turbidity, and coliform water quality objectives. The MBR treatment process requires approximately 4 acres, somewhat less than extended aeration MLE. The compact size of the system facilitates siting and minimizes land acquisition costs.
- BIOLAC® Wastewater Treatment System. The BIOLAC® process is a proprietary activated sludge process developed by Parkson Corporation. The BIOLAC® system is similar to the extended aeration MLE process with multiple “cells” in a large, lined earthen basin to facilitate biological treatment of the wastewater. The BIOLAC® system is typically designed for a microorganism solids residence time (SRT) of approximately 50 days compared to an SRT of approximately 6 to 15 days for the MLE process. The longer SRT reduces effluent BOD levels and provides almost complete nitrification/denitrification. Parkson Corporation claims over 500 BIOLAC® installations throughout North America treating municipal and industrial wastewater and is likely capable of meeting BOD, suspended solids and nitrogen water quality objectives. The BIOLAC® treatment process requires approximately 10 acres.
- Sequencing Batch Reactor (SBR). A sequencing batch reactor (SBR) is an activated sludge system that relies on a series of tanks. Each tank sequentially fills, aerates, settles and decants the wastewater to achieve the desired water quality objectives. SBRs have a proven history in wastewater treatment and are capable of meeting BOD, suspended solids and nitrogen water quality objectives. The SBR treatment process requires approximately 6 acres. The compact size of the system facilitates siting and minimizes land acquisition costs.

- **Oxidation Ditch.** An oxidation ditch system is an activated sludge system that consists of a ring or oval-shaped channel equipped with mechanical aeration devices. Oxidation ditches typically operate with long detention and solids retention times. The oxidation ditch system has a proven history in wastewater treatment and is capable of meeting BOD, suspended solids, and nitrogen water quality objectives. The oxidation ditch treatment process requires approximately 8 acres. The land requirement is greater than MLE, MBR, or SBR processes because surface aeration in the oxidation ditch process typically limits tank depth to approximately 12 feet.

**Attached-Growth Fixed Media.** These processes use media such as plastic or rock to support microbial growth. Wastewater is spread over the media, where the soluble organic matter is metabolized by the microorganisms and the colloidal organic matter is adsorbed on the film. Attached-growth processes require primary sedimentation tanks and would required add-on denitrification facilities to meet the expected 7 mg/L total nitrogen requirement. If necessary for the selected disposal/reuse alternative, filtration and disinfection would be required in addition to the attached-growth fixed media secondary treatment process to produce Title 22 unrestricted reuse tertiary recycled water.

- **Trickling Filters.** Trickling filters are an aerobic attached-growth biological treatment process that may include nitrification (the conversion of ammonia to nitrate) but are not typically employed to obtain low levels of nitrogen. If low levels of effluent nitrogen are required, typically multi-stage filters including methanol addition would be required. The trickling filter process has a proven history in wastewater treatment and is capable of meeting BOD and suspended solids, but has generally not been used to meet low levels of nitrogen. To meet secondary treatment levels for suspended solids, a supplemental contact tank is usually required. The trickling filter process requires approximately five acres. The compact size of the system facilitates siting and minimizes land acquisition costs. The trickling filter process usually includes towers 20 to 30 feet high, which can be a visual obstruction.
- **Rotating Biological Contactors (RBCs).** Rotating biological contactors are an aerobic attached-growth biological treatment process that may include nitrification (the conversion of ammonia to nitrate) but are not typically employed to obtain low levels of nitrogen. RBCs consist of a series of closely spaced circular disks submerged in wastewater and rotated slowly through it. As with trickling filters, clarification is required after the RBCs. RBCs have a proven history in wastewater treatment, although historically not as widely used as trickling filters, and are capable of meeting BOD and suspended solids limits. As with trickling filters, RBC systems are generally not capable of meeting low levels of nitrogen.

The RBC process requires approximately 4 to 6 acres. The compact size of the system facilitates siting and minimizes land acquisition costs.

- **Packed-Bed Filters.** Packed bed filters utilize hanging synthetic fibers as a fixed substrate for aerobic growth in pre-manufactured fiberglass pods with nominal dimensions of 8 feet by 16 feet. These pod-packed-bed filters are commonly used for commercial and small residential applications that utilize STEP/STEG collection. Packed-bed filters are a very new treatment process and there is little experience with long-term operation of this technology in municipal treatment plants. Most experience with the process is with small scale or on-site systems. According to the Los Osos Wastewater Management Plan Update (Ripley Pacific Company, July 2006), approximately 410 pod filters are required to accommodate a flow of 1.3 mgd at an application rate of 25 gallons per day per square foot (gpd/sf). A packed-bed filter system requires approximately 4 to 6 acres. The cost to distribute and collect process flow from this quantity of filters is likely impractical and would result in a relatively high construction costs.

**Advanced Wastewater Treatment Ponds.** Advanced wastewater treatment ponds is a broad term to classify large earthen or concrete basins used to stabilize domestic wastewater by natural biological processes that occur in shallow ponds. Numerous variations of treatment ponds exist to optimize suspended solids, BOD, fecal microorganisms and ammonia removal. Descriptions are provided for several types of relatively common pond systems. If necessary for the selected disposal/reuse alternative, coagulation, filtration, and disinfection would be required in addition to the advanced pond secondary treatment process to produce Title 22 unrestricted reuse tertiary recycled water.

- **Advanced Integrated Wastewater Pond System (AIWPS®).** The Advanced Integrated Wastewater Pond System was assessed for use in Los Osos in the Wastewater Facilities Project, Draft Project Report (Oswald Engineering Associates, January 2000). AIWPS is generally differentiated from AIPS technology by including shallow high-rate algal ponds. AIPS is similar to partially mixed facultative ponds with some adjustments. The advanced facultative and initial high rate ponds remove about 40 percent of the plant influent nitrogen by incorporation into algae. The algal mass is removed in the algal settling pond and dissolved air flotation unit. The flow is then conveyed to another set of high rate ponds where approximately 55 percent of the plant influent nitrogen is removed by another algal biomass. A second set of settling ponds and dissolved air flotation are required to remove this algal biomass. Effluent nitrogen is predicted to be approximately 8 mg/L. Filtration would be required to achieve the water quality objective of 7 mg/L total nitrogen (Oswald Engineering Associates, January 2000). Advanced Integrated Wastewater Pond Systems have a proven history of BOD and suspended solids

removal, but have generally not been used to meet low levels of nitrogen. Documented nitrogen removal performance data is limited and acceptance by the RWQCB to meet the waste discharge requirements is questionable. The AIWPS® treatment process requires approximately 64 acres for the treatment ponds and emergency storage ponds as recommended by Oswald Engineering Associates, Inc. The significant area required, assuming nitrogen removal is required at some point in time, would severely limit the potential treatment plant sites.

- Facultative Ponds with Constructed Wetlands. Facultative organisms function with or without dissolved oxygen. Facultative ponds are generally aerobic, however, these ponds do operate in a facultative manner and have an anaerobic zone. Dissolved oxygen is supplied by algae living within the pond and atmospheric transfer through wind action. Treatment in a facultative pond is provided by settling of solids and reduction of organic oxygen demanding material by bacterial activity. Facultative ponds are usually four to eight feet in depth and can be viewed as having three layers. The top six to eighteen inches is aerobic where aerobic bacteria and algae exist in a symbiotic relationship. The aerobic layer is important in maintaining an oxidizing environment in which gases and other compounds leaving the lower anaerobic layer are oxidized. The middle two to four feet is partly aerobic and partly anaerobic, in which facultative bacteria decompose organic material. The bottom one to two feet is where accumulated solids are decomposed by anaerobic bacteria. Aerobic reactions in facultative ponds are limited because they do not have mechanical aeration. Facultative and anaerobic reactions need more time than aerobic reactions to provide the same degree of treatment. The detention time of facultative ponds is typically over 120 days. This process utilizes constructed wetlands for the final step to provide nitrogen removal.

This system has been used at many facilities to meet BOD and suspended solids requirements for all disposal/reuse alternatives. However, the wetlands provide limited control and have water quality impacts resulting from wildlife contact. Nitrogen levels of 8 to 10 mg/L may be achieved but filtration would be required to comply with turbidity limits for reuse alternatives and achieve nitrogen levels of approximately 7 mg/L. Permitting this system would be problematic for most reuse/disposal alternatives due to the limited control and likely variations in effluent quality. The facultative ponds and constructed wetlands treatment process requires approximately 60 to 90 acres. The area required limits the potential treatment plant sites.

- Partially Mixed Facultative Ponds. Partially mixed facultative ponds include proprietary designs such as Nelson Air Diffusion System (ADS)®

and Advanced Integrated Pond System (AIPS)®. Specific design requirements will be considered during detailed evaluation and design, if applicable. Partially mixed facultative ponds can be viewed as a combined biological process that oxidizes organic oxygen demanding material and a physical operation that allows settling of organic and inorganic solids. Mechanical aeration provides dissolved oxygen needed for aerobic organisms in the pond to convert and oxidize the organic material in the wastewater. It also provides the physical mixing necessary to distribute dissolved oxygen, suspend the organic material and bring the organisms into contact with the organic material. Mixing must not be so great as to prevent the settling of solids for both sedimentation and for facultative and anaerobic degradation. Partially mixed facultative ponds provided with adequate aeration can be deeper and smaller than facultative ponds. Typical partial mix ponds are 10 to 16 feet deep and have a detention time of 30 to 60 days. This system has been used at many facilities to meet BOD and suspended solids requirements for all disposal/reuse alternatives. Nitrogen levels of 8 to 10 mg/L may be achieved but the system offers limited control. Filtration would be required to comply with turbidity limits for reuse alternatives and achieve nitrogen levels of approximately 7 mg/L. The partially mixed facultative pond treatment process requires approximately 20 acres. A dual power aerated lagoon would require slightly less area. The area may limit the potential treatment plant sites.

- (2) Decentralized Treatment. Decentralized treatment is a wastewater management strategy that utilizes several cluster, or neighborhood, collection and treatment facilities within a larger community. They typically utilize STEP/STEG collection systems and packed bed filters, or other packaged designs, for the treatment process. This option reduces the amount and costs of pipeline for collection and effluent distribution. The County included this option in the alternatives considered and evaluated it through a series of technical memoranda. The County released a draft technical memoranda that identified issues and requirements that were specific to a decentralized treatment alternative for Los Osos. The County then retained Pio Lombardo, of Lombardo Associates, Inc., a nationally recognized expert on decentralized treatment, to develop a conceptual plan and cost estimates for Los Osos. The County then completed a final technical memorandum on the subject and incorporated it into the environmental analysis for the project EIR.

The decentralized conceptual plan developed by Pio Lombardo included seven collection and treatment zones located throughout the community. The system included a STEP/STEG collection system with a recirculating media filter followed by Nitrex denitrification filter treatment process. The denitrification filter would be necessary to meet the 7 mg/L total nitrogen requirements. Tertiary filtration and disinfection would also be provided to produce Title 22 recycled



water for unrestricted reuse. The recycled water would be distributed to the individual residences for irrigation use or percolation through existing leachfields.

- (3) Onsite Treatment. Onsite treatment is a wastewater management strategy that utilizes individual, onsite treatment facilities at each individual home or business. This option does not require a collection system and typically uses a package treatment process. Due to the existing pollution problem of high nitrogen levels in the groundwater, an additional denitrification process would also be required on each system. The treated effluent is used for sub-surface irrigation or discharged to a leachfield. The County included this option in the alternatives considered and evaluated it through in a technical memorandum and incorporated it into the environmental analysis for the project EIR.
- (4) Regional Treatment. Regional treatment is a wastewater management strategy that combines the treatment facility for multiple communities or wastewater authorities. This option allows for cost sharing for construction and operation of the treatment facilities and may realize some economies of scale. The County included this option in the alternatives considered and evaluated it through in a technical memorandum and incorporated it into the environmental analysis for the project EIR. The other wastewater agencies considered for regional treatment are the Morro Bay/Cayucos Sanitary District and/or the California Mens Colony, a state prison. A regional treatment facility with Los Osos and one of these agencies would require a capacity of 2.4 mgd, a facility with Los Osos and both of these agencies would require a capacity of 3.7 mgd. Several alternative locations were evaluated, as well as, the pipeline routes to convey wastewater from each service area to the treatment facility. A regional treatment plant would present unique opportunities and challenges for water supply management related to the reuse of the treated effluent.

c. Effluent Reuse and Disposal.

The Rough and Fine Screening Reports, Technical Memoranda, and project EIR reviewed of a number of effluent reuse/disposal alternatives, including unrestricted urban and agricultural reuse, percolation ponds, sub-surface leachfields, sprayfields, creek discharge, constructed terminal wetlands, and direct groundwater injection.

Unrestricted Urban Reuse. Unrestricted urban reuse is the practice of using treated wastewater to irrigate landscaping in areas where public access is not restricted and requires tertiary disinfected recycled water in accordance with CA Title 22. Urban reuse would reduce pumping from the groundwater basin for potable uses, thus helping with overall groundwater management. Urban reuse was considered in Wastewater Facilities Project Final Project Report (Montgomery Watson Americas, March 2001) for irrigation of schools, parks and golf courses. The Final Project Report indicated that there are not nearly enough potential sites for water reuse in the community of Los Osos to accept all of the treated effluent. The irrigation flow for large urban water users was estimated to be 132 acre-feet/year. In terms of residential

use of reclaimed water, approximately half of the water use in Los Osos is for outside irrigation, so there is significant potential for water reuse.

Unrestricted Agricultural Reuse. Unrestricted agricultural reuse is the practice of using treated wastewater to irrigate food crops that can be eaten raw and where the irrigation water comes in contact with the crop. This requires tertiary disinfected recycled water in accordance with CA Title 22. Agricultural reuse in areas overlying the Los Osos groundwater basin would reduce pumping from the groundwater basin and provide some benefit to overall groundwater management. The extent of the agricultural reuse depends on demand from growers. The recycled water could provide irrigation for as much as 600 to 800 acres, if up to 150 days (650 acre-feet) of seasonal storage is provided.

Percolation Ponds. Percolation ponds are open ponds where water is stored and percolated into the ground. The pond bottoms are managed to maintain percolation rates by drying, ripping and conditioning the soils. Site requirements for this strategy are similar to those for leachfields in that they function best with permeable soil and sufficient depth to groundwater. A percolation pond could be as large as several acres. Construction of a percolation pond involves the excavation of the pond itself and trenches for supply pipes. The area converted to a percolation pond would be permanently lost to agricultural production or habitat. Due to aesthetic issues, percolation ponds would have to be located downwind, and therefore east, of residential areas. Based on the previous WDRs developed for Los Osos, both suspended solids and BOD would be limited to a monthly average of 60 mg/L and a daily maximum of 100 mg/L. Total nitrogen would be limited to a monthly average of 7 mg/L and a daily maximum of 10 mg/L.

Leachfields. Leachfields are operated by subsurface spreading and percolation, so there is no open water. There are limited areas within the groundwater basin that would be appropriate for subsurface leachfields. The Broderson Site, identified as the disposal option for the LOCSO project, has a capacity of 448 acre feet per year, which is much less than the effluent flow projected for the future wastewater treatment facility. Harvest wells could be used to effectively double the site's capacity, but this route requires a separate plan for collecting, treating and disposing of the harvest water. Other potential leachfields sites in the community include the existing large septic system that serves the Bayridge Estates subdivision and disposes of approximately 33 acre feet per year. Additional potential leachfield sites could be constructed on ranch and agricultural lands east of the community in the vicinity of the potential treatment plant locations. The capacity of a disposal leachfield greatly depends on the permeability of the soil and the depth to the underlying groundwater. For example, the Broderson Site was identified as a favorable location because of the permeability of the underlying soils (mostly dune sand) and its connectivity with the shallow aquifer. By contrast, soils associated with agricultural fields generally exhibit slower percolation rates. Construction of a leachfield involves the excavation of trenches and the installation of percolation and supply pipe. Based on the previous WDRs developed for Los Osos, both suspended solids and BOD would be limited to

a monthly average of 60 mg/L and a daily maximum of 100 mg/L. Total nitrogen would be limited to a monthly average of 7 mg/L and a daily maximum of 10 mg/L.

Sprayfields. Sprayfield disposal is the practice of spraying effluent on lands to grow a crop which requires large amounts of water. Water is disposed through evapotranspiration and percolation. Care must be taken to ensure that runoff is reduced and contained. The capacity of sprayfields to accept treated wastewater would be greatest during the dry season. Spraying of fields during the rainy season would accelerate erosion and sedimentation as well as the volume of runoff conveyed by natural drainage courses. Additionally, most WDR's prohibit spraying immediately before, during, or immediately after a rainfall event. Since the capacity of the sprayfields is reduced during the rainy season, a portion of the treated wastewater would need to be stored. Under this strategy, treated wastewater would be sprayed on grazing land east of town where it would percolate into the ground or simply evaporate into the air. If the use of sprayfields is the sole disposal strategy, about 600 acres would be needed. There are several large holdings east of the community used for grazing which may be potentially suitable. The viability of this strategy depends, in part, on the ability to purchase, or negotiate contractual arrangements for the use of sufficient acreage to accommodate the desired level of disposal.

Creek Discharge. Creek discharge is the practice of disposing wastewater to a surface water body, such as a creek. Discharge to surface waters would be regulated by an NPDES permit and would have to meet the strict requirements of the California Toxics Rule for metals and organics. There are several creeks in the Los Osos area, including Los Osos Creek, which runs along the southern, eastern and northern edges of the community. Los Osos Creek empties into Morro Bay, which borders the community on its western edge. All the creeks in the Los Osos area, as well as Morro Bay, are subject to total maximum daily loads (TMDLs), since they are classified as impaired water bodies. The creeks and Morro Bay are also designated as having body contact recreation as a beneficial use, which requires Disinfected Tertiary treatment. Due to impairment and the TMDLs, nitrate (as nitrogen) would likely be limited to an average of 2.2 mg/L (Montgomery Watson Americas, Inc., 2001). Since Los Osos Creek has been issued a TMDL for sediments, pathogens, nutrients and dissolved oxygen, the treatment facility would be issued a waste load allocation for these constituents.

Constructed Terminal Wetlands. Wetlands serve an important role in improving water quality, providing flood protection and important habitat. Constructed wetlands can be used for treatment, for mitigation for destruction of wetlands elsewhere or for creation of habitat. They are also considered as a disposal method if it is necessary to release recycled water to maintain the wetland. A terminal wetland has no discharge to surface waters and is designed to evaporate and percolate wastewater effluent for disposal. This is essentially a variant of the percolation pond strategy in which the pond (or ponds) consists of newly constructed wetlands or the expansion/augmentation of existing wetlands. Wetlands have both aesthetic and

biological value, in addition to possessing certain water purifying qualities. A constructed wetland could be combined with larger conservation/restoration efforts such as those undertaken by the Morro Bay National Estuary Program or other regional efforts to improve/restore water quality and biodiversity. The most suitable sites, therefore, would be those adjacent to existing wetlands where the opportunity for expansion or augmentation currently exists.

Direct Groundwater Injection. Groundwater injection is the practice of injecting wastewater into a groundwater aquifer, usually deep underground. Groundwater injection can be considered to be water reuse and is regulated by the California of Department of Health Services (DHS). Disinfected tertiary treatment is required as a minimum. However, all groundwater injection projects that have been implemented in California have been required to add membranes, such as reverse osmosis, to the treatment process. Treatment by reverse osmosis requires a disposal option for the concentrated brine that results from the process. Based on the DHS published draft regulations for planned direct and indirect recharge of groundwater, BOD will be limited to the concentration of dissolved oxygen in the effluent and total nitrogen will likely be limited to an average of 5 mg/L and a maximum of 10 mg/L. The DHS requires extensive monitoring and testing to protect public health, and there are strict guidelines for distance to nearest wells, time of travel to nearest well, depth to groundwater, percolation rate versus application rate, treatment level and water quality.

d. Solids Handling.

The Rough and Fine Screening Reports, Technical Memoranda, and project EIR reviewed of a number of biosolids treatment technologies and handling alternatives, including hauling off-site for treatment or disposal of dewatered sub-Class B (unclassified), digested Class B, or heat dried Class B and the recycling of composted Class B, composted Class A, or digested and composted Class A.

Sub-Class B Biosolids. This is the solids treatment and disposal alternative planned for the Tri-W Project. Sub-Class B biosolid production includes two unit processes: thickening followed by mechanical dewatering or solar drying. This alternative results in minimal construction of on-site treatment facilities but has relatively high disposal costs due to increased tipping fees charged by off-site facilities. Biosolids hauled to the off-site facilities receive further treatment by a contract operator prior to recycling/disposal. Sub-Class B gives the community the flexibility to add more treatment equipment in the future to upgrade to Class A or B biosolids for hauling or local recycling.

Digested Class B Biosolids. Digested Class B biosolids is similar to the previous alternative with the addition of a digestion treatment process. Digestion would occur between the thickening and dewatering operations to further stabilize the sludge and reduce the overall volume. The digestion process is assumed to produce Class B biosolids. Class B biosolids have more options for off-site recycling/disposal than

Sub-Class B biosolids, however, the capital and operating costs associated with digestion are greater than those costs associated with producing a Sub-Class B biosolids. Digested Class B gives the community the flexibility to add more treatment equipment in the future to upgrade to Class A biosolids for local recycling.

Heat Dried Class B Biosolids. Thermal drying to produce heat dried Class B biosolids uses a mechanical dryer instead of a digester. Heat drying occupies a smaller site footprint and facilitates containment of the treatment system for odor control. In the future, should the decision be made to produce Class A biosolids the Class B dryer would need significant modifications and may ultimately entail the purchase of a new dryer. Alternatively, a dryer sized to produce Class A biosolids could be purchased initially, and operated at a reduced level to make Class B biosolids. Then, should the decision be made to produce Class A, a new dryer would not have to be purchased.

Composted Class B Biosolids. Composted Class B biosolids expands upon hauling of Sub-Class B biosolids with the addition of a composting process after the dewatering process. The composting process will allow the community to produce Class B biosolids, increasing the hauling options for off-site recycling/disposal.

Composted Class A Biosolids. Composted Class A biosolids is similar to the option of composted Class B biosolids. The major differences are the time that the biosolids are required to remain in the composting facility, and the required temperature for composting. This extra time and temperature requirement necessitates only a slightly larger composting facility. The final biosolids product, however, can have been treated to the Class A level. This would allow for the greatest range of options for recycling/disposal of the biosolids including local recycling within the community. If local recycling is pursued, marketability and public acceptance of the biosolids should be investigated as part of the planning process. Additional screening of the biosolids will likely be required to remove the majority of plastics and hair that the public will likely find objectionable.

Digested/Composted Class A Biosolids. Digested/composted Class A biosolids are similar to the above recycling option except that digestion is included between the thickening and dewatering operations to further stabilize the sludge and reduce the overall volume. This alternative has the most complex operations requirements and significant capital investment. As with the above recycling option, marketability and public acceptance of the biosolids should be investigated as part of the planning process for local recycling.

e. Treatment Facility Site.

Andre 2. The Andre property is a narrow, triangular shaped parcel bordering LOVR. The site slopes gently downward to the north and contains one dwelling. Access is currently provided from the adjacent parcel in common ownership. There is one group of large trees that follows an ephemeral drainage that crosses the northerly

portion of the site. The useable area of site is about 9 acres, but narrow triangular shape limits development flexibility. Access to the site is from LOVR, which is adjacent.

Branin. The Branin property is an irregularly shaped 42.2 acre parcel north of LOVR and west of Clark Valley Road. The site is adjacent to Warden Lake which consists of native wetland and riparian vegetation. The site slopes to the north and contains two ephemeral drainages. Access to the site is provided by a dirt road that wraps around the Cemetery Property and provides access to surrounding farming operations.

Cemetery Property. The Cemetery Property consists of a rectangular 47.4 parcel north of Los Osos Valley Road (LOVR) and west of Clark Valley Road. The Los Osos Mortuary and Memorial Park occupies the southerly portion of the site (about 19 acres). The site slopes gently downward to the north; the westerly boundary slopes downward to the west to a dirt road that provides access to surrounding farming operations. There are no large trees or other natural features. Access is provided from LOVR by way of a level, unimproved road bordering on the east that intersects LOVR opposite Clark Valley Road.

Giacomazzi. The Giacomazzi property is a rectangular 38.2-acre parcel north of LOVR and west of Clark Valley Road. The site slopes gently downward to the north and east toward an ephemeral drainage that extends along the easterly portion of the site to Warden Lake (offsite). The channel supports a small oak woodland along its northerly reaches adjacent to the Branin property. There is a collection of farm-related buildings along the western border with numerous tall trees surround the buildings. The level areas of the site have been plowed, but are not regularly cultivated with crops. Access to the site is provided by way of an unimproved road bordering on the east that intersects LOVR opposite Clark Valley Road.

Gorby. The Gorby property is an irregular 51.7 acre parcel south of LOVR on the east bank of Los Osos Creek. The southerly half of the parcel is steeply sloped and heavily wooded and is not suitable for building. The northern half is level and contains a residence and equestrian farm with paddocks and riding arenas. This area is Class 1 agricultural soil. The level area contains approximately 20 – 25 acres of buildable land. However, the parcel is adjacent to Los Osos Creek on its longest side and creek setbacks would significantly reduce the buildable area. Additional constraints are that the parcel is within a 100 year floodplain and is proximate to a presumed seismic fault. Access to the site is by an unimproved road across neighboring agricultural parcel from LOVR opposite Sombrero Road.

Mid-Town (aka Tri-W). The Mid-Town property is a rectangular 11 acre parcel north of LOVR and west of Palisades Avenue within the urban area of Los Osos. The parcel is owned by the LOCSO and was purchased as the treatment facility site for the LOCSO project. The parcel was graded in 2005 by the LOCSO's contractor and is gently sloping. A large amount of urban runoff passes through the site, which required a drainage basin as part of the LOCSO plans. The entire parcel is located on

Los Osos dune sands, which is designated as environmentally sensitive. The parcel is served by all urban utility services and access is from the adjacent LOVR or Palisades Avenue.

Morosin/FEA. The Morosin property is an irregular 81.2 acre parcel south of LOVR on the east side of Clark Valley Road. The southerly half of the parcel is steeply sloped and heavily wooded and is not suitable for building. The northern half is gently sloped and suitable for building. The parcel contains a church and parking area on the northeastern portion. PG&E easements for high-voltage powerlines restrict the western 400 – 500 feet of the parcel. The useable area is approximately 35 acres. Access is from the adjacent Clark Valley Road.

Robbins 1. The Robbins 1 property consists of a mostly rectangular 41.1 acre parcel abutting the north side of LOVR east of Clark Valley Road. The site contains at least one dwelling and slopes to the north toward Warden Lake. Large mature trees surround the farm buildings. The site may be used for grazing and the buildable portion of the site is about 30 acres. Access to the site is from LOVR, which is adjacent.

Robbins 2. The Robbins 2 property is a mostly rectangular 43.5 acre parcel abutting the north side of LOVR east of Clark Valley Road. The site slopes to the north toward Warden Lake. The site may be used for grazing and the buildable portion of the site is about 35 acres. Access to the site is from LOVR, which is adjacent.

Tonini. The Tonini property is an irregular 645 acre parcel on Turri Road, north of LOVR. Portions of the parcel are Class 2 agricultural soil and are used for row crops. The upland areas are used for grazing. The parcel contains a historic ranch complex with a residence, barn and other out-buildings. There are approximately 175 acres of flat to gently sloped areas suitable for building. Access to the site is from Turri Road.

#### 5.4. EVALUATION CRITERIA

The evaluation criteria for the project components include life-cycle costs, environmental impacts, greenhouse gas emission/carbon footprint, energy use, property owner/customer impacts, future growth capacity, water quality, water conservation and reuse, and benefits/impacts to the treatment process. Extensive discussion and evaluation of the alternatives are presented in the Rough and Fine Screening Reports, selected Technical Memoranda, and the project EIR. The following is a summary of key evaluation considerations for each project component.

- a. Collection System. The Rough Screening Report includes several case studies for each of the alternative collection system technologies. These case studies identified operational issues and were used to develop long-term operations and maintenance cost estimates in the Fine Screening Report. The Fine Screening Report focuses on gravity and STEP/STEG alternatives and developed detailed estimates of both capital and operations and maintenance costs. The report includes an in-depth evaluation of

the issues related to retrofitting the existing properties from septic systems to a community-wide collection system. Subsequent to the rough and fine screening analysis the County conducted detailed evaluations the collection system alternatives related to key issues in several of the project technical memoranda.

The Low Pressure Collection System technical memorandum evaluated low pressure, grinder pump systems to a similar level of detail as that provided for the gravity and STEP/STEG alternatives in the Fine Screening Report. The technical memorandum includes an expanded case study of similar systems and considered on-lot impacts, construction methods, and pump performance. A detailed estimate of both capital and operations and maintenance costs was also developed.

The Flows and Loads technical memorandum provided detailed estimates of the anticipated flows to the treatment facility from both the gravity and STEP/STEG collection system alternatives. A key evaluation factor was the potential impacts of infiltration and inflow.

The Out of Town Conveyance technical memorandum evaluated potential pipeline routes and construction methods for delivering raw wastewater to treatment facility locations east of the wastewater service area. Alternative pump station locations were evaluated and an estimate of both capital and operations and maintenance costs was also developed.

The Greenhouse Gas Emissions technical memorandum estimated the greenhouse gas emission of all of the project components, including collection system alternatives. For the collection system, besides the indirect emissions resulting from electricity consumption, key emission sources were from septic tank venting and septage hauling associated with the STEP/STEG system.

The overall engineering evaluation in the rough and fine screening analysis and the technical memoranda provided detailed evaluations of many issues which may have significant impact on costs, future flexibility, operations, and maintenance. The key issues include:

- Individual property (on-lot) construction costs and impacts
- Individual property (on-lot) operation and maintenance requirements
- Operations and maintenance costs – including RWQCB monitoring and maintenance requirements
- Conveyance to out-of-town treatment facility alternatives and cost estimates
- Life cycle costs from individual properties to treatment facility
- Impacts and benefits to treatment facility associated with varying influent quality from each collection system
- Greenhouse gas emissions from each collection system
- Easement requirements



The project EIR provides additional evaluation of the collection system alternatives and is included with the project financing application. The key areas of analysis in the EIR that relate to the collection system include groundwater, biological, and cultural resources.

b. Treatment Process.

The approach to evaluating treatment process alternatives in the Rough Screening Report includes:

- Fatal Flaw Analysis - An alternative will be removed from consideration if it has a characteristic that will clearly impede its implementation, from either a cost, regulatory, institutional or technical standpoint.
- Elimination of Redundancy - An alternative will be removed from consideration if it is equivalent to the alternative that has already been developed for the LOCSD's Tri-W Project.
- Removal of Equivalent Alternatives - An alternative will be removed from consideration if there is another alternative that is clearly superior in one respect, even if they are otherwise comparable.

The Fine Screening Report focused on seven treatment alternatives and developed detailed cost estimates of both capital and operations and maintenance costs. The report includes evaluation of treatment capabilities to meet the expected nitrogen limit of 7 mg/L and upgrade to tertiary treatment. Overall, the rough and fine screening analysis include the following evaluation criteria.

- Construction cost
- Operations and maintenance costs
- Land (acreage) requirements
- Nitrogen removal capabilities
- Tertiary treatment compatibility
- Sludge production quantity and quality
- Energy consumption
- Greenhouse gas emissions
- Odor control capabilities
- Potential neighborhood impacts

In addition to the rough and fine screening analysis, the County conducted detailed evaluations of alternative treatment approaches in several of the project technical memoranda.

The Partially Mixed Facultative Pond technical memorandum evaluated facultative pond treatment processes to an additional level of detail not provided in the Fine Screening Report in order to evaluate address several key issues. The evaluation included a more detailed review of dam safety issues, nitrogen removal capabilities,

algae removal, energy consumption, and a comparison between different facultative pond technologies.

The Onsite Treatment technical memorandum evaluated the potential installation of onsite treatment systems on a community-wide scale. The evaluation included a review of operational issues, the ability to dispose of, or reuse, the treated effluent, sea water intrusion mitigation, on-lot impacts, and regulatory/permitting issues. A general estimate of the capital costs per residence was also developed.

The Decentralized Treatment technical memorandum evaluated the potential for developing a decentralized wastewater collection, treatment, and disposal plan consisting of several treatment facilities located throughout the community. The evaluation included a review of operational issues, community issues, the ability to dispose of, or reuse, the treated effluent, sea water intrusion mitigation, treatment facility site constraints, and regulatory/permitting issues. A detailed estimate of both capital and operations and maintenance costs was also developed for specific decentralized alternatives in Los Osos by Lombardo Associates, Inc.

The Regional Treatment technical memorandum evaluated the potential for combining the Los Osos treatment facility with neighboring facilities at Morro Bay or the California Mens Colony. The evaluation included a review of treatment facility site constraints, pipeline routes, contractual issues, the ability to dispose of, or reuse, the treated effluent, sea water intrusion mitigation, and regulatory/permitting issues. A general estimate of both capital and operations and maintenance costs was also developed.

c. Effluent Reuse and Disposal.

The approach to evaluating effluent reuse and disposal alternatives in the rough and fine screening analysis had two primary criteria. The evaluation focused on the ability of each alternative to mitigate the sea water intrusion that is occurring in the community's drinking water aquifer and achieve a balanced groundwater basin. Additionally, the evaluation considered the feasibility of each alternative to be implemented by the County, acting as the wastewater authority, or whether other partners were required that were beyond the control of the County or beyond the scope of a wastewater project. Detailed estimates of both capital and operations and maintenance costs were also developed.

In addition to the rough and fine screening analysis the County provided further detailed evaluation in the Effluent Reuse and Disposal technical memorandum. The technical memorandum provided further details for the most viable alternatives and evaluated various scenarios of combined alternatives. The overall evaluation of reuse and disposal alternatives included the following considerations.

- Mitigation of sea water intrusion.
- Feasibility within the scope of the wastewater project

- Construction cost
- Operations and maintenance costs
- Water quality objectives required for each alternative, including treatment level, suspended solids limits, BOD limits, and total nitrogen limits.
- Salt and mineral loading.
- Total capacity of each alternative relative to total wastewater flows.
- Winter and operational storage requirements.
- Flexibility for future growth within build-out projects of the General Plan.
- Land requirements.
- Regulatory/permitting requirements.
- Dam safety issues.
- Seasonal demand or capacity.
- Ability to phase development and avoid stranded costs

d. Solids Handling.

The Rough Screening Report recognizes the uncertainty of the direction of the biosolids disposal regulations at the state and local levels and establishes the primary criteria that the solids handling facilities be designed in a manner that allows for the greatest treatment and disposal flexibility. At the same time, this flexibility must be sensitive of environmental constraints, community values, footprint availability, energy usage, continued operations and maintenance requirements, and capital cost. It includes the following assumptions for evaluating solids handling alternatives.

- Class A biosolids production should include composting. Other options for long-term Class A production and management would pose a significant acceptance risk.
- Due to a local ordinance, non-composted Class A biosolids must either be hauled off-site or land applied at a regional location. The transportation costs and tipping fees do not favor hauling Class A over that of Class B. Therefore, there is no perceived benefit to the production of non-composted Class A biosolids.
- Alkaline stabilization will not be pursued due to the likely difficulties associated with regulatory approval and mitigation requirements while limiting the biosolids market.

The Fine Screening Report evaluated the solids handling alternatives in greater detail, taking into consideration the impacts of the collection system and treatment process alternatives. Detailed estimates of both capital and operations and maintenance costs were also developed.

In addition to the rough and fine screening analysis the County provided further detailed evaluation in the two technical memoranda. The Solids Handling technical memorandum provided further details for the most viable alternatives including end use options, co-generation potential, solar greenhouse drying, and composting. The

Septage Receiving Station technical memorandum considered the potential impacts and benefits of collection and treatment of additional solids by establishing a regional septage receiving center. The evaluation concluded that a regional septage receiving station would not be cost effective in Los Osos. The overall evaluation of solids handling alternatives included the following considerations.

- Future flexibility
- Capital costs
- Operations and maintenance costs
- Federal, state and local regulations and permitting requirements
- Land requirements
- Co-generation options
- Regional septage receiving options
- Local land disposal constraints
- Storage requirements

e. Treatment Facility Site. The evaluation criteria for potential treatment facility sites are presented in the following table, taken from the Rough Screening Report, and are a summary of the issues considered in rough and fine screening analysis.

<b>Table 5.2 Treatment Facility Site Requirements and Issues</b>	
<b>Siting Requirements</b>	<b>Issues</b>
Acreage and Topography	<ul style="list-style-type: none"> <li>• Must be of sufficient size and level topography to accommodate all of the facilities associated with a particular treatment technology.</li> <li>• More land intensive technologies have a higher potential to adversely affect sensitive biological, archaeological and/or agricultural resources.</li> </ul>
Flood Hazard	<ul style="list-style-type: none"> <li>• A suitable site for a wastewater treatment plant must avoid, or be protected from, the potential affects of flooding.</li> <li>• A treatment plant location should not contribute to downstream flooding or worsen an existing drainage problem.</li> <li>• Areas near Los Osos Creek and its tributaries are subject to flooding during major storm events (See Section 5.3.2).</li> </ul>
Access to Infrastructure	<ul style="list-style-type: none"> <li>• A suitable site must be accessible to supporting infrastructure               <ul style="list-style-type: none"> <li>– Roadways of sufficient size and capacity to accommodate the types of service vehicles and level of traffic anticipated.</li> <li>– A stable source of water and electricity.</li> </ul> </li> </ul>

<b>Table 5.2 Treatment Facility Site Requirements and Issues</b>	
<b>Siting Requirements</b>	<b>Issues</b>
Sensitive Resources	
Agricultural Land	<ul style="list-style-type: none"> <li>• Farmland suitability classifications for the properties as mapped by the California Department of Conservation (See Section 5.3.2).</li> <li>• The California Land Conservation Act (California Government Code Section 51290 et seq.) encourages the conservation of agricultural lands by providing a tax incentive to land owners who contract with the County to restrict land uses to agriculture and compatible uses.               <ul style="list-style-type: none"> <li>– Properties subject to an LCA contract must remain in agricultural use for the duration of the contract, a minimum of ten years.</li> <li>– A property owner may cancel the contract by filing a Notice of Non-renewal and the contract is terminated at the end of ten years.</li> <li>– The law provides for the cancellation of a contract but only under special circumstances and only after the Board of Supervisors makes certain specific findings.</li> <li>– The Gorby and Branin properties are subject to an Agricultural Preserve, making them eligible for an LCA contract.</li> </ul> </li> </ul>
Biological Resources	<ul style="list-style-type: none"> <li>• The Los Osos area provides habitat for a number of special status species, as well as other sensitive biological resources that include riparian corridors (Los Osos Creek) and wetlands. Special-status species are plants and animals that are either listed as 'endangered' or 'threatened' under the Federal or California Endangered Species Acts, listed as 'rare' under the California Native Plant Protection Act, or considered to be rare (but not formally listed) by resource agencies, professional organizations, and the scientific community.</li> <li>• The area contains Environmentally Sensitive Habitat Areas (ESHA), which are subject to additional protections prescribed by the California Coastal Act.</li> </ul>
Archaeological Resources	<ul style="list-style-type: none"> <li>• Over 60 archaeological sites have been identified among the stabilized dunes of Los Osos and extending to the east along both sides of Los Osos Creek and beyond.</li> <li>• The potential to un-earth previously undiscovered archaeological resources should be considered high, especially for sites near Los Osos Creek.</li> </ul>
Hydro-Geology, Soils and Geological Hazards	<ul style="list-style-type: none"> <li>• Geologic constraints that could affect the suitability of a site for treatment facilities include:               <ul style="list-style-type: none"> <li>– The presence of an active fault trace.</li> <li>– The presence of unstable or expansive soils.</li> <li>– Shallow groundwater.</li> <li>– Slope instability.</li> </ul> </li> <li>• The Paso Robles Formation comprises the plateau and gently rolling hill area east of the alluvial deposits adjacent to Los Osos Creek where the majority of potential sites are located. Sediments of the Paso Robles Formation are generally equivalent to stiff to hard cohesive soils and medium dense to very dense granular soils that are less suitable for farming but are suitable for building sites (See Section 5.3.2).</li> <li>• The Los Osos fault is considered 'active' and a portion of the fault zone near the intersection of Los Osos Valley Road and Foothill Boulevard, about 7 miles to the southeast, lies within a Seismic Special Study Zone as prescribed by the State of California Alquist-Priolo Special Studies Zones Act. The potential exists for fault rupture to affect sites in the vicinity.</li> </ul>
Visual Resources	<ul style="list-style-type: none"> <li>• The placement of treatment facilities along these corridors will need to include architectural and landscape mitigation to prevent adversely impacting scenic resources.</li> </ul>

<b>Table 5.2 Treatment Facility Site Requirements and Issues</b>	
<b>Siting Requirements</b>	<b>Issues</b>
Proximity of Sensitive Receptors	<ul style="list-style-type: none"> <li>The design of a treatment plant must consider the management of odors and impacts to surrounding sensitive receptors, which include residential neighborhoods, farms and ranches, businesses, and public/quasi-public facilities (schools, churches, etc.).</li> </ul>
Regulatory Issues	<ul style="list-style-type: none"> <li>Land use within the unincorporated County is governed by the San Luis Obispo County General Plan and Land Use Ordinance.</li> <li>An Agriculture and Open Space Element has been adapted by the County to guide the protection of significant agricultural resources.</li> <li>The community of Los Osos and the area inland of Los Osos Creek fall within the Coastal Zone as defined by the California Coastal Act of 1976. Provisions of the Coastal Act are aimed at protecting important coastal resources and 'environmentally sensitive habitat areas'. Policies of the Coastal Act establish fairly precise criteria to govern the location and design of a 'wastewater treatment works' within the Coastal Zone.</li> <li>The federal Clean Water Act establishes standards for water quality as well as governing activities that may impact 'waters of the United States', such as perennial streams and estuaries.</li> <li>And lastly, the Los Osos area is known to support habitat for a number of species listed in accordance with the California and federal Endangered Species Acts. These laws address direct and indirect impacts to special status plant and animal species and set forth a process through which these species are to be protected from land development activities.</li> </ul>
Proximity to Collection Service Area and Disposal Sites	<ul style="list-style-type: none"> <li>The more distant the treatment plant is from the collection area, the greater is the potential for construction and operational impacts associated with the collection main that conveys wastewater to the plant.</li> </ul>
Other Site-Specific Factors	<ul style="list-style-type: none"> <li>Other factors to be considered include (but are not limited to) easements or other private restrictions on the title of a given site.</li> </ul>

## 5.5. MAPS

Figure 5.1 shows the location of potential collection system pipelines within the community for any alternative and the pump station locations that would be required with a gravity system.

Figure 5.2 shows the alternative treatment facility sites that were considered in the engineering and environmental analysis. [DEIR Ex. 7-1 or FSR (sites)]

Figure 5.3 shows several potential pipeline routes for conveyance of raw wastewater to a treatment facility east of the community. Further information is available in the Out of Town Conveyance Technical Memorandum included in the Appendices. [DEIR Ex. 7-2 or TM (conveyance routes)]

Figure 5.4 shows the viable effluent reuse and disposal alternatives for the project. [DEIR Ex. 7-3 or FSR/TM (reuse/disposal options)]

Figure 5.1 Project Diagram

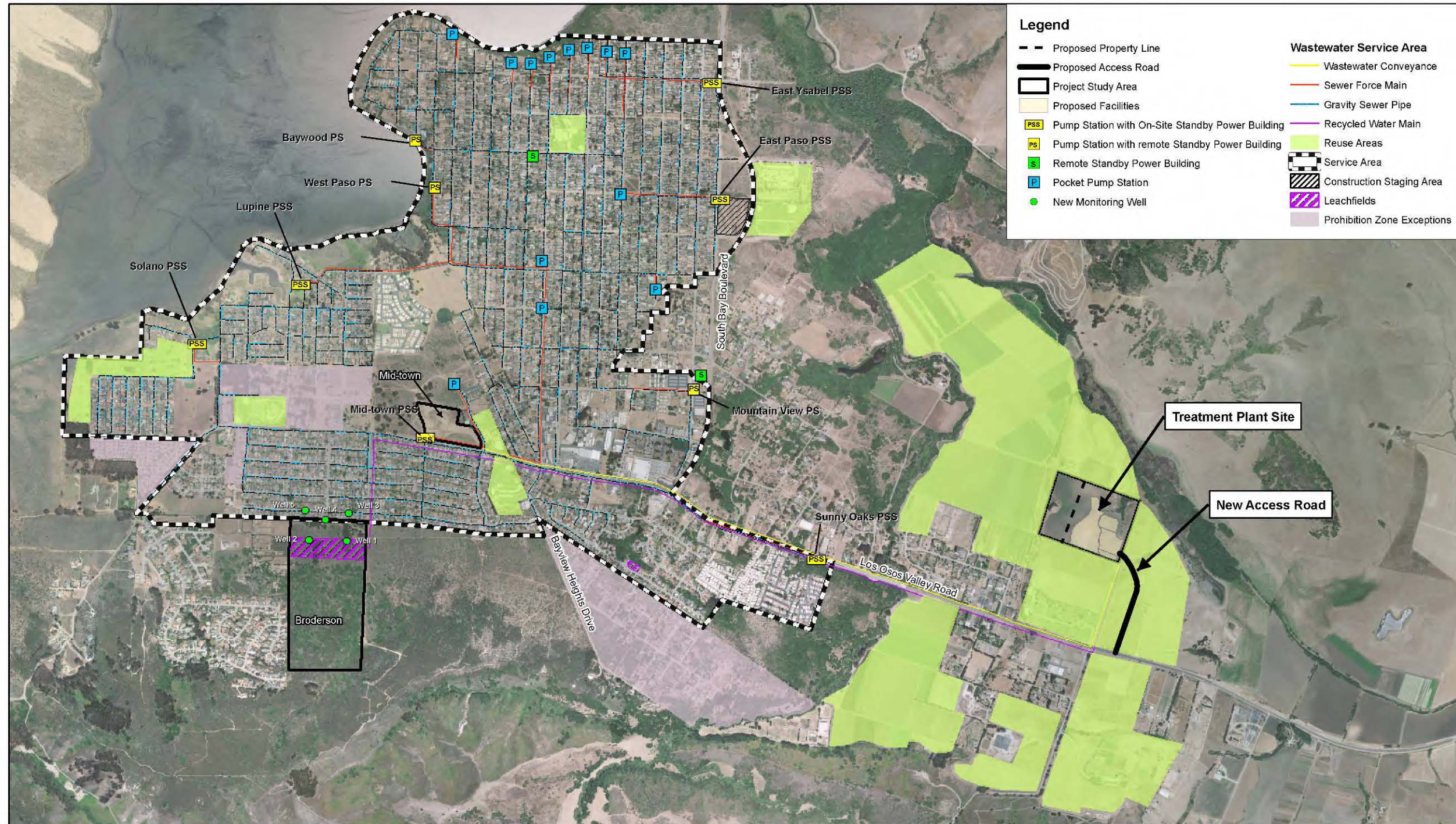

Source: 2007 Digital Globe aerials, San Luis Obispo County GIS Data, Carollo Engineers, and MBA GIS Data.

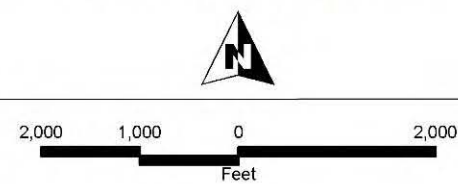

Figure 1  
Overall Project Site Plan  
Los Osos Wastewater Project, County of San Luis Obispo, 2009

COUNTY OF SAN LUIS OBISPO • LOS OSOS WASTEWATER PROJECT



Figure 5.2 Treatment Plant Site Alternatives



Source: AirPhoto USA, San Luis Obispo County GIS Data, and MBA GIS Data.

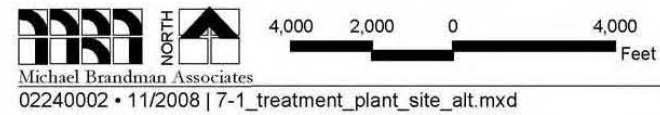

Exhibit 7-1  
Wastewater Treatment Plant Site Alternatives

COUNTY OF SAN LUIS OBISPO • LOS OSOS WASTEWATER PROJECT  
ENVIRONMENTAL IMPACT REPORT

Figure 5.3 Out-of-Town Conveyance Route Alternatives



Source: AirPhoto USA, San Luis Obispo County GIS Data, and MBA GIS Data.

Michael Brandman Associates  
 02240002 • 10/2008 | 7-2\_conveyance\_routes\_tonini.mxd

Exhibit 7-2  
Out of Town Conveyance Routes to Tonini Ranch Site

COUNTY OF SAN LUIS OBISPO • LOS OSOS WASTEWATER PROJECT  
ENVIRONMENTAL IMPACT REPORT

Figure 5.4 Effluent Disposal and Recycled Water Reuse Alternatives



Source: AirPhoto USA, San Luis Obispo County GIS Data, and MBA GIS Data.

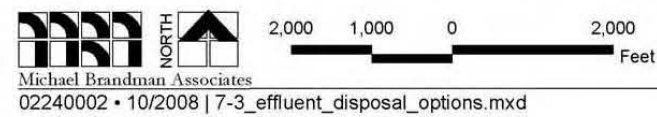

02240002 • 10/2008 | 7-3\_effluent\_disposal\_options.mxd

Exhibit 7-3  
Effluent Disposal Options

COUNTY OF SAN LUIS OBISPO • LOS OSOS WASTEWATER PROJECT  
ENVIRONMENTAL IMPACT REPORT

#### 5.6. ENVIRONMENTAL IMPACTS

Analysis of the potential environmental impacts is included in the environmental documents. The project objective, relative to environmental impacts, is avoidance as the first priority. Any impacts to sensitive habitat or resources that cannot be avoided will be fully mitigated. There will be not direct or indirect impacts on important environmental resources.

Virtually all of the collection system and recycled water distribution components to be constructed will be located in existing roadways or other previously disturbed areas. Where it is necessary for the pipeline routes to cross Los Osos Creek, both the raw wastewater and recycled water mains will be hung from the existing bridge. The primary exception to the impacts avoidance objective is the 8 acres of leachfields on the Broderson site, which is a sensitive habitat area. The impacts at Broderson will be mitigated by the preservation of the remaining 80 acres of the site as permanent open space and species habitat. The treatment facility and associated solids handling facility will be located on previously disturbed land under all site alternatives.

#### 5.7. CARBON FOOTPRINT/GREENHOUSE GAS EMISSIONS

The project alternative analysis included consideration of global warming impacts, in response to California Assembly Bill 32, which mandates that these issues be considered and a reduction in greenhouse gases. Greenhouse gas emission were analyzed in a Technical Memorandum and, separately, in the project EIR. The table below is a summary of the analysis, which compares collection system and treatment process alternatives, while assuming that effluent reuse is a combination of leachfields and irrigation and that solids handling is hauling unclassified sludge to a nearby landfill or composting facility. Gravity collection and extended aeration treatment processes (oxidation ditch/Biolac) were found to have the least carbon footprint of the collection and treatment alternatives.

<b>Table 5.3 Greenhouse Gas Emissions Summary: Annual Metric Tons of CO<sub>2</sub> Equivalent</b>								
<b>Alternatives</b>	<b>Indirect</b>						<b>Direct</b>	<b>Total</b>
	<b>Operations Energy</b>	<b>Construction Production</b>	<b>Chemical Production</b>	<b>Construction Materials</b>	<b>Solids &amp; Septage</b>	<b>Chemical Handling</b>	<b>Septic Tank Venting</b>	<b>Metric Tons CO<sub>2</sub> equivalent</b>
Existing Septic Systems	0	0	0	0	16	0	840	<b>856</b>
Gravity w/ Oxidation Ditch	769	143	48	32	47	22	0	<b>1,061</b>
STEP/STEG w/ Oxidation Ditch	549	103	389	22	14	23	624	<b>1,724</b>
Gravity w/ BIOLAC	657	136	47	38	47	22	0	<b>947</b>
STEP/STEG w/ BIOLAC	464	99	389	26	14	23	624	<b>1,639</b>
Gravity w/ Fac. Ponds	655	138	389	49	9	20	0	<b>1,260</b>
STEP/STEG w/ Fac. Ponds	560	100	389	39	10	21	624	<b>1,742</b>

## 5.8. PUBLIC PARTICIPATION/COMMUNITY SURVEY

The County has created several ongoing opportunities for public involvement and input on the wastewater project. These include regular (weekly or monthly) public hearings at the Board of Supervisors and TAC, town-hall and open house style community meetings, a project website with up-to-date information and documents, email and web-log forums for asking questions or posting comments, and a community-wide project survey that was mailed to all residents and property owners. The community survey was conducted in February, 2009, following the engineering alternatives analysis in the Rough and Fine Screening Reports and Technical Memoranda, and after the release of the draft EIR. The survey questions focused on costs and issues that affected individual residents, the overall community, or the environment. The results of the survey are advisory only and are used by County decision-makers in considering the project.

## 5.9. LAND REQUIREMENTS

A summary of land requirement is provided below. Additional information is available in the Alternative Description and Advantages/Disadvantages discussions in this section and in the attached documents.

- a. Collection System. Land requirements are similar for the pipeline portion of each collection system alternative. However, there are some important distinctions between the alternatives for the other collection system facilities. The gravity system requires nine pumps stations and thirteen pocket pump stations. All of these will be located in the road right-of-way or other publically owned land and all of the locations have been evaluated and previously permitted by the environmental resource agencies for the LOCSO project. Each of the alternative collection systems (STEP/STEG, vacuum, or low pressure grinder pumps) require on-site tanks or vaults to be installed on each property. Due to the density of the development in Los Osos it is likely that there will be conflicts with other facilities that will result in delays or increased costs. Vacuum systems also require large, above-grade vacuum stations, in addition to underground pump stations. No locations for these vacuum stations have been identified.
- b. Treatment Process and Solids Handling. Land requirements for the treatment process alternatives generally range from 5 to 10 acres for all of the extended aeration/activated sludge and the attached growth/fixed media technologies. Land requirements for the Advanced Wastewater Treatment Ponds are more variable and range from 20 acres for Partially Mixed Facultative Ponds to 60 to 90 acres conventional Facultative Ponds. The acreage estimates include allowances for appurtenant facilities including administration and maintenance buildings, tertiary treatment processes, and most solids handling alternatives.
- c. Effluent Reuse and Disposal. Land requirements for effluent reuse or disposal consist of the 8 acres at the Broderson site for leachfields and approximately 10 acres at the Giacomazzi site for storage ponds to facilitate irrigation reuse options. The urban and

agricultural reuse options do require any additional land, or land use conversion. The existing uses of these sites will be maintained, but irrigated with recycled, rather than potable, water. Sprayfields would require up to several hundred acres, depending on the capacity required. It would be necessary to convert the land from its previous use for dedicated irrigation of crops which have a high water intake capacity. Percolation ponds and terminal wetlands would require large amounts of land in order to have significant capacity. No suitable location for these facilities was identified in the alternatives review.

#### 5.10. CONSTRUCTABILITY ISSUES

The treatment facility site alternatives are large, greenfield, sites with suitable soil conditions and no existing facilities to avoid. Constructability issues for the project are largely focused on the collection system, with the following key issues.

- **Sandy Soil:** The community of Los Osos is an ancient sand dune and virtually all of the collection system pipelines will be installed in sandy soil. The soil typical will maintain vertical excavations for a period of time. However, shoring and sheeting will likely be required for worker safety and constructability.
- **High Groundwater:** Selected portions of the planned collection system are in areas of high groundwater. These areas have been mapped, with depth-to-groundwater contours developed. This information will be available to potential contractors, prior to submitting bids. It is expected that extensive dewatering operations and/or alternative construction techniques such as trenchless pipe installation will be required in limited areas.
- **Utility Conflicts:** Utility mapping and coordination was completed for the entire collection system area as part of the LOCSD's project in 2005. Any new development since 2005 has been tracked and coordinated to avoid potential conflicts with the planned sewer pipelines. However, portions of the potable water system are not well mapped and contains transite pipe, which is difficult to locate. A pre-construction potholing program will be required as part of the construction contract.
- **Cultural Resources:** There is a long history of Native American settlements in the Los Osos area. Extensive archeological surveys were conducted for the entire collection system prior to the LOCSD's project in 2005. Pipeline routes were designed to avoid sensitive areas when possible. The construction contract will have provisions for addressing delays and construction impacts associated with encountering artifacts in the pipeline excavations.
- **On-lot Construction:** The gravity collection system alternative will only be constructed within the public right-of-way or easements. Sewer laterals will be constructed to the edge of the right-of-way and all on-lot lateral connections and septic tanks abandonment will be the responsibility of the individual property owner. The other collection system alternatives (STEP/STEG, vacuum, and low pressure grinder pumps) require some type of holding tank, septic tank, or pump vault to be installed on private property at each of the approximately 4,800 connections. Since these facilities must be properly maintained in order to ensure reliable system operation, the County would be responsible for the installation and maintenance. The individual property owner coordination, yard

restoration, site constraints, and contractor liability for each of the 4,800 connections would present significant constructability issues.

#### 5.11. COST ESTIMATES

Cost estimates were developed in the Fine Screening Report, and in subsequent technical memoranda for each of the project components. The following tables summarize the cost estimates for construction, non-construction (soft costs), and operations and maintenance.

Tables 5.4 through 5.14 summarize construction and operations and maintenance costs in 2007 dollars (ENR 7879) for the collection system, treatment facility, solids handling, and effluent reuse and disposal alternatives.

Table 5.15 and 5.16 provide a summary of the total project construction costs, non-construction capital costs and long-term operations and maintenance costs.



**Table 5.4 Range of Probable Costs for Gravity Collection System**

Item <sup>(2)</sup>	Range of Probable Costs		Notes on Development of Range
	Low (\$M) <sup>(1)</sup>	High(\$M) <sup>(1)</sup>	
Mobilization/Demobilization/ General Conditions	3.7	4.0	Based on 5% of Construction Cost Subtotal
<b>COMMON FACILITIES</b>			
Gravity Sewers and Force Mains	27.8	30.6	Low estimate based on Carollo Engineer's Unit Price Catalog with 15% contractor overhead and profit and 8% sales tax. High estimate includes 10% contingency due to final design level.
Manholes	4.3	4.7	Low estimate based on Carollo Engineer's Unit Price Catalog with 15% contractor overhead and profit and 8% sales tax. High estimate includes 10% contingency due to final design level.
Shoring and Dewatering	4.8	5.3	Low estimate based on Carollo Engineer's Unit Price Catalog with 15% contractor overhead and profit and 8% sales tax. High estimate includes 10% contingency due to final design level.
Duplex Pump Station	2.6	2.6	Based on Bid Tab values.
Triplex Pump Station	1.2	1.2	Based on Bid Tab values.
Pocket Pump Station	2.4	2.4	Based on Bid Tab values.
Standby Power Facility	2.5	2.5	Based on Bid Tab values.
Miscellaneous Facility Requirements	3.3	3.3	Based on Bid Tab values.
Laterals in Right of Way	8.8	9.7	Low estimate based on Carollo Engineer's Unit Price Catalog with 15% contractor overhead and profit and 8% sales tax. High estimate includes 10% contingency due to final design level.
Road Restoration	5.2	5.2	Based on bid assessment by the Wallace Group, March 2005
Land and Easement Acquisition	Assumed No Additional Cost <sup>(3)</sup>		

**Table 5.4 Range of Probable Costs for Gravity Collection System**

Item <sup>(2)</sup>	Range of Probable Costs		Notes on Development of Range
	Low (\$M) <sup>(1)</sup>	High(\$M) <sup>(1)</sup>	
<b>ON-LOT FACILITIES</b>			
Project Facilities	0.0	0.0	All on-lot costs assumed to be borne by the individual homeowners for gravity/low pressure systems
Homeowner Facilities	12.6	13.9	Based on on-lot options and cost development information presented above. High estimate includes 10% contingency.
Overhead and Profit (15%)	Included Above <sup>(4)</sup>	Included Above <sup>(4)</sup>	
Subtotal	\$79.3	\$85.5	
Sales Tax (8%)	Included Above <sup>(4)</sup>	Included Above <sup>(4)</sup>	
Conveyance to Out-of-Town Treatment Facility	2.9	4.1	
<b>TOTAL CONSTRUCTION COST</b>	<b>\$82.2</b>	<b>\$89.6</b>	
Notes:			
(1) All costs in April 2007 dollars, based on an ENR of 7879.			
(2) Prohibition zone lots only - 4,769 connections.			
(3) Land and easement acquisition assumed to be sunk cost as part of previous Tri-W project.			
(4) Contractor overhead and profit and sales tax assumed included in bid tab values. Where Unit Price Catalog estimates are used, contractor overhead and profit (15%) and sales tax (8%) are included in the individual line items.			

<b>Table 5.5 Range of Probable Costs for Low Pressure Collection System (LPCS)</b>			
<b>Item <sup>(2)</sup></b>	<b>Range of Probable Costs</b>		<b>Notes on Development of Range</b>
	<b>Low (\$M) <sup>(1)</sup></b>	<b>High (\$M) <sup>(1)</sup></b>	
Mobilization/Demobilization/General Conditions COMMON FACILITIES <sup>(5)</sup>	3.0	3.9	Based on 5% of Construction Cost Subtotal.
Force Mains and Laterals in Right-of-Way	11.7	15.2	Low estimate based on Los Osos Wastewater Management Plan Update (Ripley 2006) and installation costs from Tidwell. High estimate includes 30% contingency due to conceptual design level.
Duplex Pump Station (6)	2.6	2.6	Based on Bid Tab Values and Table 3.1, Fine Screening Report
Triplex Pump Station (2)	1.2	1.2	Based on Bid Tab Values and Table 3.1, Fine Screening Report
Standby Power Facility (7)	2.5	2.5	Based on Bid Tab Values and Table 3.1, Fine Screening Report
Miscellaneous Facility Requirements	3.3	3.3	Based on Bid Tab Values and Table 3.1, Fine Screening Report
Odor Control	0.1	0.3	Low and High estimates based on 100 and 500 air release valves respectively at \$500 each.
Road Restoration	1.3	2.6	Low and High estimates based on 25% and 50% of the gravity system requirements, respectively, due to estimated reduction in pavement disturbance.
Land and Easement Acquisition	Assumed No Additional Cost <sup>(3)</sup>	Assumed No Additional Cost <sup>(3)</sup>	
<b>ON LOT FACILITIES</b>			
Project Facilities	21.8	24.0	All on-lot costs assumed to be borne by the individual homeowners for low pressure systems
Homeowner Facilities	6.6	7.3	Based on on-lot options and cost development information presented above. High estimate includes 10% contingency similar to gravity system.
Electrical Connection	9.1	18.1	Low and High estimates based on community average costs of \$1,900 and \$3,800 per connection as presented in Table 8 for 4769 Prohibition Zone lots.
Subtotal	\$63.2	\$81.0	
Overhead and Profit (15%)	\$9.5	\$12.2	
Subtotal	\$72.7	\$93.2	
Sales Tax (8%) <sup>(4)</sup>	\$2.9	\$3.7	
<b>TOTAL CONSTRUCTION COST <sup>(6)</sup></b>	<b>\$75.6</b>	<b>\$96.9</b>	
Notes:			
(1) All costs in April 2007 dollars, based on an ENR of 7879.			
(2) Prohibition Zone lots only - 4769 connections.			
(3) Land and easement acquisition assumed to be sunk cost as part of the previous Tri-W project.			
(4) Sales Tax included on materials only. Assumed 60 percent materials cost for common and on-lot facilities.			
(5) Common Facilities estimates assumed to be the same for low pressure system as for STEP system.			

<b>Table 5.6 Range of Probable Costs for STEP/STEG Collection System</b>			
<b>Item <sup>(2)</sup></b>	<b>Range of Probable Costs</b>		<b>Notes on Development of Range</b>
	<b>Low (\$M) <sup>(1)</sup></b>	<b>High (\$M) <sup>(1)</sup></b>	
Mobilization/Demobilization /General Conditions	2.6	3.2	Based on 5% of Construction Cost Subtotal.
<b>COMMON FACILITIES</b>			
Force Mains and Laterals in Right-of-Way	11.7	15.2	Low estimate based on Los Osos Wastewater Management Plan Update (Ripley 2006) and installation costs from Tidwell. High estimate includes 30% contingency due to conceptual design level.
Odor Control	0.1	0.3	Low and High estimates based on 100 and 500 air release valves respectively at \$500 each.
Road Restoration	1.3	2.6	Low and High estimates based on 25% and 50% of the gravity system requirements, respectively, due to estimated reduction in pavement disturbance.
Land and Easement Acquisition	Assumed No Additional Cost <sup>(3)</sup>	Assumed No Additional Cost <sup>(3)</sup>	
<b>ON LOT FACILITIES</b>			
Project Facilities	23.5	25.8	Based on on-lot options and cost development information presented above. High estimate includes 10% contingency similar to gravity system.
Homeowner Facilities	6.1	6.7	Based on on-lot options and cost development information presented above. High estimate includes 10% contingency similar to gravity system.
Electrical Connection	9.1	14.3	Low and High estimates based on \$1,900 and \$3,000 per connection as presented in Table 3.15 for 4769 Prohibition Zone lots.
Subtotal	\$54.4	\$68.1	
Overhead and Profit (15%)	\$8.1	\$10.2	
Subtotal	\$62.3	\$78.3	
Sales Tax (8%) <sup>(4)</sup>	\$2.5	\$3.1	
<b>TOTAL CONSTRUCTION COST WITH BASE ELECTRICAL CONNECTION</b>	<b>\$65.0</b>	<b>\$81.4</b>	
Separate Electrical Service Premium	\$14.5	\$24.1	
<b>TOTAL CONSTRUCTION WITH SEPARATE ELECTRICAL SERVICE PREMIUM</b>	<b>\$79.5</b>	<b>\$105.5</b>	
Notes:			
(1) All costs in April 2007 dollars, based on an ENR of 7879.			
(2) Prohibition Zone lots only - 4769 connections.			
(3) Land and easement acquisition assumed to be sunk cost as part of the previous Tri-W project.			
(4) Sales Tax included on materials only.			

<b>Table 5.7 Estimated O&amp;M Costs for Gravity Collection System</b>				
<b>Item</b>	<b>Units</b>	<b>Quantity</b>	<b>Unit Price (\$)</b>	<b>Annual O&amp;M (\$)</b>
Labor	Hrs/year	4,160 <sup>(1)</sup>	40 <sup>(2)</sup>	170,000
Power	Kwh/year	500,000 <sup>(3)</sup>	0.12 <sup>(2)</sup>	60,000
Equipment Maintenance/ Replacement	%/year	2	Pump Station Power Facility and Misc Facility Requirements Construction Cost	250,000
<b>TOTAL O&amp;M COST<sup>(4)</sup></b>				<b>\$480,000</b>
Notes:				
(1) Based on 2 full-time employees and 2,080 hours per year.				
(2) From Basis of Cost Evaluation Technical Memorandum.				
(3) Based on energy required to convey 1.4 mgd to an out-of-town treatment facility.				
(4) Septic hauling costs for homes outside of the Prohibition Zone are not included.				

<b>Table 5.8 Estimated O&amp;M Costs for Low Pressure Collection System (LPCS)</b>				
<b>Item</b>	<b>Units</b>	<b>Quantity</b>	<b>Unit Price (\$)</b>	<b>Annual O&amp;M (\$)</b>
Labor	Hrs/year	10,400 <sup>(1)</sup>	40 <sup>(2)</sup>	420,000
Power	kWh/year	860,000 <sup>(3)</sup>	0.12 <sup>(2)</sup>	100,000
Electrical Maintenance/ Replacement	%/year	1	Electrical Connection Construction Costs	90,000
Pump/Controls Maintenance/ Replacement	Pumps/year	700 <sup>(4)</sup>	1,200-2,000 <sup>(5)</sup>	840,000-1,400,000
Odor Control Maintenance/ Replacement	%/year	20	Odor Control Construction Costs	20,000
<b>TOTAL O&amp;M COST</b>				<b>~\$1,500,000- \$2,000,000</b>
Notes:				
(1) Based on 5 full-time employees from Horseshoe Bay, Hot Springs, and other case studies contacted. Full-time equivalent (FTE) employee based on 2,080 hours per year.				
(2) From Basis of Cost Evaluation Technical Memorandum (Carollo, August 2007).				
(3) Based on energy required to convey 1.2 mgd to an out-of-town treatment facility. Assumed a grinder pump efficiency of 30 percent.				
(4) Assumes full pump replacement every 7 years.				
(5) Range based on replacement pump costs for case studies contacted.				

**Table 5.9 Estimated O&M Costs for STEP/STEG Collection System**

Item	Units	Quantity	Unit Price (\$)	Annual O&M (\$)
Labor	Hrs/year	5,200 <sup>(1)</sup>	40 <sup>(3)</sup>	210,000
Power	kWh/year	425,000 <sup>(4)</sup>	0.12 <sup>(3)</sup>	50,000
Electrical Maintenance/Replacement	%/year	1	Electrical Connection Construction Costs	90,000
Pump/Controls Maintenance/Replacement	Pumps/year	700 <sup>(5)</sup>	400 <sup>(6)</sup>	280,000
Odor Control Maintenance/Replacement	%/year	20	Odor Control Construction Costs	20,000
Septic Hauling <sup>(7)</sup>	Tanks/year	950 <sup>(8)</sup>	150 <sup>(2)</sup>	140,000
<b>TOTAL O&amp;M COST</b>				<b>~\$790,000</b>

Notes:

- (1) Based on 2.5 full-time employees from Charlotte County Utility Authority, Florida, Olympia and other case studies contacted for Rough Screen Analysis. FTE based on 2,080 hours per year.
- (2) Based on 1.5 full-time employees at \$40/hour and \$150,000 for septic hauling truck replaced every 10 years.
- (3) From Basis of Cost Evaluation Technical Memorandum.
- (4) Based on energy required to convey 1.2 mgd to an out-of-town treatment facility.
- (5) Assumes pump replacement every 7 years.
- (6) Based on pump cost provided by Orenco.
- (7) Septic hauling costs for homes outside of the Prohibition Zone are not included.
- (8) Based on anticipated RWQCB requirement for STEP tank pumping frequency of once every 5 years.

Costs <sup>(1,2)</sup>	Treatment Alternative (\$M)						
	Extended Aeration MLE	BIOLAC®	Sequencing Batch Reactor (SBR)	Oxidation Ditch	Trickling Filters	Partially Mixed Facultative Ponds	Membrane Bio-Reactor (MBR)
Gravity Collection System							
Secondary Treatment Construction Costs	\$22.2	\$17.2	\$23.0	\$19.6	\$20.5	\$14.7	\$55.0
Secondary Treatment O&M Costs	\$700,000	\$700,000	\$660,000	\$690,000	\$670,000	\$510,000	\$740,000
Nitrification Facilities Construction Costs <sup>(3,4)</sup>	-	-	-	-	\$3.8	\$1.0 - 3.8 <sup>(6)</sup>	-
Nitrification Facilities O&M Costs <sup>(3,4)</sup>	-	-	-	-	\$90,000	\$30,000 - \$90,000 <sup>(6)</sup>	-
Denitrification Facilities Construction Costs <sup>(3)</sup>	-	-	-	-	\$3.6	\$3.6	-
Denitrification Facilities O&M Costs <sup>(3)</sup>	-	-	-	-	\$250,000	\$250,000	-
STEP Collection System							
Secondary Treatment Construction Costs	\$19.1	\$14.2	\$19.4	\$16.5	\$17.6	\$13.7	N/A
Secondary Treatment O&M Costs	\$570,000	\$550,000	\$590,000	\$570,000	\$610,000	\$510,000	N/A
Nitrification Facilities Construction Costs <sup>(3,4)</sup>	-	-	-	-	\$3.3	\$1.0 - 3.3 <sup>(6)</sup>	-
Nitrification Facilities O&M Costs <sup>(3,4)</sup>	-	-	-	-	\$90,000	\$30,000 - 90,000 <sup>(6)</sup>	-
Denitrification Facilities Construction Costs <sup>(3)</sup>	\$3.6	\$3.6	\$3.6	\$3.6	\$3.6	\$3.6	\$3.6
Denitrification Facilities O&M Costs <sup>(3)</sup>	\$250,000	\$250,000	\$250,000	\$250,000	\$250,000	\$250,000	\$250,000
Gravity or STEP							
Tertiary Treatment Construction Costs <sup>(8)</sup>	\$1.6 - 3.5	\$1.6 - 3.5	\$1.6 - 3.5	\$1.6 - 3.5	\$1.6 - 3.5	\$2.1 - 4.0 <sup>(5)</sup>	- <sup>(7)</sup>
Tertiary Treatment O&M Costs <sup>(8)</sup>	\$30,000 - 100,000	\$30,000 - 100,000	\$30,000 - 100,000	\$30,000 - 100,000	\$30,000 - 100,000	\$60,000 - 130,000 <sup>(5)</sup>	- <sup>(7)</sup>
Notes:							
(1) All costs are in April 2007 dollars, based on an ENR of 7879.							
(2) Total construction costs do not include design, construction management, and legal/administrative costs. Refer to Chapter 7 for project costs.							
(3) Assumed nitrification /denitrification of full plant flow to meet seasonal disposal/ reuse requirements.							
(4) Trickling filters and facultative ponds require nitrification upstream of denitrification.							
(5) Includes additional pre-treatment costs due to high suspended solids effluent from facultative ponds.							
(6) Low costs assume fully nitrifying pond system feasible. High costs assume implementation of nitrifying trickling filters.							
(7) MBR effluent quality meets Title 22 requirements without additional treatment.							
(8) Tertiary cost range dependent on flowrate, upper range is for 1.2 MGD							
(9) Includes 30% contingency for all capital cost estimates.							

<b>Table 5.11 Capital Cost Summary for Solids Treatment Alternatives</b>			
	<b>Assumed Treatment Processes On Site</b>	<b>Estimated Capital Cost with Gravity Collection System (\$M)<sup>(1)</sup></b>	<b>Estimated Capital Cost with STEP/STEG Collection System (\$M)<sup>(2)</sup></b>
Facultative Pond	Facultative Pond	0	0
Sub-Class B Biosolids <sup>(3)</sup>	Gravity Belt Thickening Solar Drying	1.9 - 2.4 (2.6 - 3.3 with BFP Dewatering)	1.0 - 1.7 (1.4 - 2.4 with BFP Dewatering)
Digested Class B Biosolids	Gravity Belt Thickening Aerobic Digestion Solar Drying	4.6 - 5.1 (5.3 - 6.0 with BFP Dewatering)	2.4 - 3.5 (2.8 - 4.2 with BFP Dewatering)
Heat Dried Class B Biosolids	Gravity Belt Thickening Belt Filter Press Dewatering Indirect Heat Drying	5.5 - 6.2	3.0 - 4.4
Composted Class B Biosolids	Gravity Belt Thickening Belt Filter Press Dewatering Windrow Composting	3.6 - 4.3	1.9 - 3.2
Composted Class A Biosolids	Gravity Belt Thickening Belt Filter Press Dewatering Windrow Composting	3.6 - 4.3	1.9 - 3.2
Digested/ Composted Class A Biosolids	Gravity Belt Thickening Aerobic Digestion Belt Filter Press Dewatering Windrow Composting	6.3 - 7.0	3.3 - 5.0
Notes:			
(1) Based on an average solids volume from primary and secondary treatment process of 4,000 pounds per day (dry weight).			
(2) Based on an average solids volume from primary and secondary treatment process of 1,000 pounds per day (dry weight).			
(3) The Tri-W Project included treatment and disposal of Sub-class B biosolids.			
(4) Includes 30% contingency for all estimates.			



<b>Table 5.12 O&amp;M Cost Summary for Solids Treatment Alternatives</b>			
	<b>Assumed Treatment Processes On Site</b>	<b>Estimated O&amp;M Cost with Gravity Collection System (\$M)<sup>(1)</sup></b>	<b>Estimated O&amp;M Cost with STEP/STEG Collection System (\$M)<sup>(2)</sup></b>
Facultative Pond	Facultative Pond Temporary Equipment	0.04 – 0.05 <sup>(3)</sup>	0.03 – 0.04 <sup>(3)</sup>
Sub-Class B Biosolids <sup>(4)</sup>	Gravity Belt Thickening Solar Drying Hauling	0.43 – 0.47 (0.63 - 0.66 with BFP Dewatering)	0.18 – 0.25 (0.28 – 0.38 with BFP Dewatering)
Digested Class B Biosolids	Gravity Belt Thickening Aerobic Digestion Solar Drying Hauling	0.43 – 0.47 (0.63 – 0.66 with BFP Dewatering)	0.18 – 0.25 (0.28 – 0.38 with BFP Dewatering)
Heat Dried Class B Biosolids	Gravity Belt Thickening Belt Filter Press Dewatering Indirect Heat Drying Hauling	0.60 – 0.62	0.30 – 0.42
Composted Class B Biosolids	Gravity Belt Thickening Belt Filter Press Dewatering Windrow Composting Hauling	0.68 – 0.71	0.35 – 0.48
Composted Class A Biosolids	Gravity Belt Thickening Belt Filter Press Dewatering Windrow Composting Hauling	0.62 – 0.65	0.33 – 0.46
Digested/ Composted Class A Biosolids	Gravity Belt Thickening Aerobic Digestion Belt Filter Press Dewatering Windrow Composting Hauling	0.63 – 0.66	0.33 – 0.46
Notes:			
(1) Based on an average solids volume from primary and secondary treatment process of 4,000 pounds per day (dry weight).			
(2) Based on an average solids volume from primary and secondary treatment process of 1,000 pounds per day (dry weight).			
(3) Based on \$600,000 in 2007 dollars escalated at 5% per year until 2027 and saved for in equal annual installments.			
(4) The Tri-W Project included treatment and disposal of Sub-class B biosolids.			

**Table 5.13 Capital Cost Summary for Effluent Reuse and Disposal Alternatives**

Item	Estimated Costs	Notes
Conservation Program	\$1,000,000 - \$5,000,000	1
Piping to Sprayfield	\$1,210,000 - \$1,650,000	2
Sprayfield Development	\$20,000 - \$80,000	3
Sprayfield Maintenance Equipment	\$700,000 - \$2,800,000	4
Sprayfield Land Acquisition	\$1,800,000 - \$7,000,000	5
Recycled Water Storage Ponds	\$400,000 - \$3,900,000	6
Recycled Water Pump Station	\$780,000 - \$1,500,000	7
Recycled Water Return Main to Broderson	\$2,200,000 - \$2,900,000	8
Broderson Leachfield Development	\$2,367,000	9
Urban Reuse Turnout Piping	\$1,400,000 - \$2,100,000	10
(1) Minimum program: 5000 toilets at \$200 each. (2) 10,500 ft from Giacomazzi to Tonini. (3) \$209/acre. (4) \$256/acre/year for 30 years. (5) \$30,000/acre for spray fields, capped at \$7m (price of Tonini Ranch). (6) Range from 30 AF to 290 AF storage. (7) See costs in treatment plant information. (8) 17,700 ft from plant to Broderson. (9) Based on bid tabs for LOCSD project. (10) Estimate 10,000 lf to 15,000 lf for turnouts to ag sites, schools, and Sea Pines at \$143/lf. (11) Includes 30% contingency for all estimates. (12) Cost estimates summarized from Table A1 of Fine Screening Report (Carollo, August, 2007) for Alternatives 1a & 1b, 2a & 2b, and 3a & 3b.		

**Table 5.14 O&M Cost Summary for Effluent Reuse and Disposal Alternatives**

Item	Estimated Annual O&M Cost	Notes
<i>Sprayfields</i>		
Energy	\$67,000 - \$187,000	1
Labor	\$0 - \$89,000	2
<i>Leachfields</i>		
Energy	\$160,000 - \$170,000	3
Labor	\$90,000	4
<i>Recycled Water Reuse</i>		
Energy	\$34,000 - \$44,000	5
(1) Energy from pumping plus fuel for spray field maintenance machinery. (2) Labor for spray field maintenance - \$40/hr. (3) Energy from pumping and leachfield maintenance. (4) Labor for leachfield maintenance - \$60/hr. (5) Energy from pumping to ag land. (6) Cost estimates summarized from Table A1 of Fine Screening Report (Carollo, August, 2007) for Alternatives 1a & 1b, 2a & 2b, and 3a & 3b.		

**Table 5.15 Total Project Capital Cost Summary (\$ Millions)**

Project Element		Seawater Intrusion Mitigation Level 1		Seawater Intrusion Mitigation Level 2		Seawater Intrusion Mitigation Level 3		Tri-W Project
		90 AFY	140 AFY	190 AFY	240 AFY	550 AFY	600 AFY	~285 AFY
Collection System	STEP	\$65 - 81	\$65 - 81	\$65 - 81	\$65 - 81	\$65 - 81	\$65 - 81	\$N/A
	Gravity <sup>(7)</sup>	\$82 - 90	\$82 - 90	\$82 - 90	\$82 - 90	\$82 - 90	\$82 - 90	\$81 - 82
Treatment (Liquid and Solids) <sup>(2)</sup>	STEP	\$14 - 18	\$23 - 25	\$20 - 22	\$23 - 25	\$23 - 25	\$23 - 25	N/A <sup>(8)</sup>
	Gravity	\$15 - 22	\$23 - 26	\$20 - 22	\$23 - 26	\$23 - 26	\$23 - 26	\$55
Disposal/Reuse		\$13 - 16	\$13 - 14	\$15 - 17	\$13 - 14	\$26 - 30	\$26 - 27	\$20 - 23
Treatment Facility Site <sup>(3)</sup>		\$1 - 3	\$1 - 3	\$1 - 3	\$1 - 3	\$1 - 3	\$1 - 3	\$1 - 3
Permitting/Mitigation <sup>(4)</sup>		\$1 - 2	\$1 - 2	\$1 - 2	\$1 - 2	\$1 - 2	\$1 - 2	\$1 - 2
Total Construction Costs	STEP	\$94-120	\$103 - 126	\$102-125	\$103-126	\$116-142	\$116-139	N/A
	Gravity	\$110-130	\$118-133	\$117-132	\$119-133	\$132-149	\$131-146	\$155 - 162
Total Construction Costs Escalated to Mid-Point of Construction <sup>(5)</sup>	STEP	\$117-150	\$128-157	\$126-156	\$129-157	\$144-176	\$144-173	N/A
	Gravity	\$137-162	\$147-166	\$146-164	\$148-165	\$164-185	\$163-182	\$193 - 202
Project Costs <sup>(6)</sup>	STEP	\$18-24	\$18-24	\$18-24	\$18-24	\$21-26	\$21-26	N/A
	Gravity	\$16-21	\$16-21	\$16-21	\$16-21	\$19-23	\$19-23	\$12 - 17
Total Project Costs <sup>(5)</sup>	STEP	\$135-174	\$146-181	\$144-180	\$147-181	\$166-202	\$165-199	N/A
	Gravity	\$153-183	\$163-187	\$161-185	\$163-186	\$182-208	\$182-205	\$205 - 219

N/A - Not Available.

Notes:

- (1) Estimated Construction Costs in April 2007 dollars including contractor overhead and profit and 30% design contingency (feasibility-level estimate).
- (2) Shows combined costs of liquid treatment and solids treatment/disposal.
- (3) Assumes approximately 40 acres acquired, except for Tri-W Project. Actual acreage may vary depending on the final site and plant configuration.
- (4) Costs do not include land restoration costs at \$20,000 to \$50,000 per acre.
- (5) Assumes mid-point of construction is June 2011. Escalation at 24.5% of construction cost sub-total per the Basis of Cost Evaluation (Carollo Engineers, May 2007).
- (6) Project costs include design, construction management, administration and legal costs, as detailed in the Basis of Cost Memorandum in Appendix A of Fine Screening Report (Carollo, August, 2007).
- (7) Cost do not include \$13 to 25 million for electrical connection premium for separate electrical service that may be incurred if permitting and/or funding requirements stipulate this requirement and the funding is pursued.
- (8) Tri-W costs based on gravity collection system. Treatment Costs for the Tri-W Project with STEP collection are not available from bid tab information. Based on other treatment process costs, MBR costs associated with STEP collection could be approximately 10 to 15% less than when associated with a gravity collection system.

Project Element		Seawater Intrusion Mitigation Level 1		Seawater Intrusion Mitigation Level 2		Seawater Intrusion Mitigation Level 3		Tri-W Project
		90 AFY	140 AFY	190 AFY	240 AFY	550 AFY	600 AFY	~285 AFY
Collection System	STEP	\$0.8	\$0.8	\$0.8	\$0.8	\$0.8	\$0.8	N/A
	Gravity	\$0.5	\$0.5	\$0.5	\$0.5	\$0.5	\$0.5	\$0.7
Treatment	STEP	\$0.5-0.6	\$0.9-1.8	\$0.8-1.7	\$0.9-1.8	\$0.9-1.8	\$0.9-1.8	N/A <sup>(4)</sup>
	Gravity	\$0.5-0.7	\$0.8-1.8	\$0.7-1.7	\$0.8-1.8	\$0.8-1.8	\$0.8-1.8	\$0.7
Solids (Sub Class B) <sup>(2)</sup>	STEP	\$0.03-0.3	\$0.03-0.3	\$0.03-0.3	\$0.03-0.3	\$0.03-0.3	\$0.03-0.3	N/A
	Gravity	\$0.04-0.5	\$0.04-0.5	\$0.04-0.5	\$0.04-0.5	\$0.04-0.5	\$0.04-0.5	\$0.5
Disposal/ Reuse	STEP	\$0.1-0.3	\$0.1-0.2	\$0.4	\$0.4	\$0.1-1.1	\$0.3	N/A
	Gravity	\$0.1-0.3	\$0.1-0.2	\$0.4	\$0.4	\$0.1-1.1	\$0.3	\$0.4 - 0.5
Total O&M Costs	STEP	\$1.4 - 1.9	\$1.8 - 3.0	\$2.0 - 3.1	\$2.1 - 3.2	\$1.8 - 3.9	\$2.0 - 3.1	N/A
	Gravity	\$1.1 - 1.9	\$1.4 - 2.9	\$1.6 - 3.0	\$1.7 - 3.2	\$1.4 - 3.8	\$1.6 - 3.0	\$2.3 - 2.4 <sup>(3)</sup>

N/A - Not Available.

Notes:

- (1) Estimated O&M Costs in April 2007 dollars.
- (2) Low costs are based on an annuity to fund temporary, mobile facilities for removal of solids from facultative ponds 20 years following startup of the wastewater treatment facilities.
- (3) Does not include \$0.4 million for water conservation, habitat mitigation, overhead, administration and contingency to correspond to the Final Project Report (Montgomery Watson Americas, March 2001) estimate. See Table 7.2 of Fine Screening Report (Carollo, August, 2007).
- (4) Tri-W costs based on gravity collection system. Treatment Costs for the Tri-W Project with STEP collection are not available from bid tab information. Based on other treatment process costs, MBR costs associated with STEP collection could be approximately 10 to 20% less than when associated with a gravity collection system.

5.12. ADVANTAGES/DISADVANTAGES

The following tables (Table 5.17 through Table 5.21) provide a summary of advantages, disadvantages, and project issues associated with each component of the project alternatives. The discussion includes collection system, treatment process, effluent reuse and disposal, solids handling, and treatment facility sites.

<b>Table 5.17 Collection System Alternatives – Advantages, Disadvantages and Issues</b>			
<b>Collection System</b>	<b>Advantages</b>	<b>Disadvantages</b>	<b>Operations &amp; Maintenance Issues</b>
Conventional Gravity	<ul style="list-style-type: none"> <li>Limited infrastructure and construction disturbance to individual properties</li> <li>Reserve hydraulic capacity</li> <li>Power required only at pump stations</li> <li>Designed as part of LOCSD project</li> <li>No proprietary technology</li> </ul>	<ul style="list-style-type: none"> <li>Several lift stations required</li> <li>Deep excavations for pipe installation</li> <li>Requires larger pipes and manholes</li> <li>Significant I/I</li> </ul>	<ul style="list-style-type: none"> <li>Lift stations must be maintained</li> <li>Reduced septage handling</li> </ul>
STEP/STEG	<ul style="list-style-type: none"> <li>May utilize existing septic systems if in acceptable condition (no off-site pump stations required)</li> <li>Shallow excavation for pipe installation</li> <li>Small pipes and no manholes</li> <li>Minimal I/I</li> <li>Reduced organic and suspended solids loading</li> <li>Reduced biosolids production and associated hauling</li> </ul>	<ul style="list-style-type: none"> <li>Significant infrastructure and construction disturbance to individual properties (septic tanks are typically replaced because of I&amp;I and previous studies have estimated 85 to 100% of tanks to be replaced)</li> <li>Dedicated power supply required at individual properties</li> <li>Limited hydraulic capacity</li> <li>Requirement to add supplemental organic material for denitrification in treatment process</li> </ul>	<ul style="list-style-type: none"> <li>Recurring disturbance to inspect and maintain septic tanks and pumps on individual properties (Blanket easement likely required)</li> <li>Increased septage handling</li> <li>Privatization option may reduce costs</li> <li>RWQCB may impose monitoring system and additional maintenance requirements not accounted for in previous studies/estimates</li> </ul>

**Table 5.17 Collection System Alternatives – Advantages, Disadvantages and Issues**

Collection System	Advantages	Disadvantages	Operations & Maintenance Issues
Vacuum	<ul style="list-style-type: none"> <li>• Limited infrastructure and construction disturbance to individual properties</li> <li>• Shallow excavation for pipe installation</li> <li>• Small pipes and no manholes</li> <li>• Minimal I/I</li> <li>• Power only required at the vacuum stations</li> </ul>	<ul style="list-style-type: none"> <li>• Only one manufacturer of vacuum systems (AIRVAC)</li> <li>• Collection chambers and several vacuum stations required</li> <li>• Limited hydraulic capacity</li> </ul>	<ul style="list-style-type: none"> <li>• Vacuum stations and interface valves must be maintained</li> <li>• Reduced septage handling</li> </ul>
Low Pressure	<ul style="list-style-type: none"> <li>• Minimized clogging because of grinder pumps</li> <li>• Shallow excavation for pipe installation</li> <li>• Small pipes and no manholes</li> <li>• Minimal I/I</li> </ul>	<ul style="list-style-type: none"> <li>• Significant infrastructure and construction disturbance to individual properties</li> <li>• Primary and back-up power supply required at individual properties</li> <li>• Limited hydraulic capacity</li> <li>• Lift stations may be required</li> </ul>	<ul style="list-style-type: none"> <li>• Recurring disturbance to maintain pumps and power source on individual properties (Blanket easement likely required)</li> <li>• Reduced septage handling</li> <li>• Privatization options to be investigated</li> </ul>
Combined (Gravity/Vacuum/Low Pressure)	<ul style="list-style-type: none"> <li>• Can optimize technology for localized conditions</li> <li>• Previously designed gravity system serves as design basis</li> </ul>	<ul style="list-style-type: none"> <li>• Similar to individual collection systems</li> <li>• Non-uniformity of design and construction</li> </ul>	<ul style="list-style-type: none"> <li>• Multiple techniques required to operate and maintain system</li> </ul>

<b>Table 5.18 Treatment Process Alternatives – Advantages, Disadvantages and Issues</b>						
<b>Treatment Alternative</b>	<b>Relative Construction Cost</b>	<b>Relative O &amp; M Cost</b>	<b>Estimated Acreage Required<sup>1,2</sup> (Acres)</b>	<b>Approximate Nitrogen Removal Capabilities (mg/L)<sup>(4)</sup></b>	<b>Relative Energy Usage</b>	<b>"Good Neighbor" Features</b>
<b>Suspended Growth Activated Sludge</b>						
Extended Aeration MLE	Moderate	Moderate	6	Probably less than 10	Moderate	<ul style="list-style-type: none"> <li>• Odor treatment as necessary</li> <li>• Low noise/enclosable equipment</li> <li>• Covered facility not cost-effective</li> </ul>
Membrane Bio-Reactor (MBR)	High	Moderate	4 <sup>3</sup>	Probably less than 10	High	<ul style="list-style-type: none"> <li>• Odor treatment as necessary</li> <li>• Low noise/enclosable equipment</li> <li>• Covered facility for multi-use options feasible</li> </ul>
BIOLAC®	Low	Low	10	Probably less than 10	Low	<ul style="list-style-type: none"> <li>• Basin size prohibits odor control</li> <li>• Low noise/enclosable equipment</li> <li>• Covered facility not feasible</li> </ul>
Sequencing Batch Reactor (SBR)	Moderate	Moderate	6	Probably less than 10	Moderate	<ul style="list-style-type: none"> <li>• Odor treatment as necessary</li> <li>• Low noise/enclosable equipment</li> <li>• Covered facility not cost-effective</li> </ul>
Oxidation Ditch	Moderate	Moderate	8	Probably less than 10	Moderate	<ul style="list-style-type: none"> <li>• Odor control as necessary but costly for oxidation ditch</li> <li>• Low noise/enclosable equipment</li> <li>• Covered facility not feasible</li> </ul>
<b>Attached-Growth Fixed Media</b>						
Trickling Filters	Moderate	Moderate	5	Probably greater than 10	Low	<ul style="list-style-type: none"> <li>• Odor control as necessary</li> <li>• Low noise</li> <li>• Covered facility not feasible</li> </ul>
Rotating Biological Contactors (RBCs)	Moderate	Moderate	4-6	Probably greater than 10	Low	<ul style="list-style-type: none"> <li>• Odor treatment as necessary</li> <li>• Low noise</li> <li>• Covered facility not cost-effective</li> </ul>
Packed Bed Filters	High	Moderate	4-6	Probably greater than 10	Low	<ul style="list-style-type: none"> <li>• Odor control as necessary</li> <li>• Low noise</li> <li>• Covered facility not feasible</li> </ul>

<b>Table 5.18 Treatment Process Alternatives – Advantages, Disadvantages and Issues</b>						
<b>Treatment Alternative</b>	<b>Relative Construction Cost</b>	<b>Relative O &amp; M Cost</b>	<b>Estimated Acreage Required<sup>1,2</sup> (Acres)</b>	<b>Approximate Nitrogen Removal Capabilities (mg/L)<sup>(4)</sup></b>	<b>Relative Energy Usage</b>	<b>"Good Neighbor" Features</b>
<b>Advanced Wastewater Treatment Ponds</b>						
Advanced Integrated Wastewater Pond System (AIWPS®)	Low	Moderate	64	Probably greater than 10	Low	<ul style="list-style-type: none"> <li>• Pond size prohibits odor control</li> <li>• Low noise/enclosable equipment</li> <li>• Covered facility not feasible</li> </ul>
Facultative Ponds and Constructed Wetlands	Low	Low	60-90	Questionable /Limited Control (Probably greater than 10)	Low	<ul style="list-style-type: none"> <li>• Limited control of water quality in wetlands</li> <li>• Pond size prohibits odor control</li> <li>• Low noise/enclosable equipment</li> <li>• Covered facility not feasible</li> </ul>
Partially Mixed Facultative Ponds	Low	Low	20 <sup>(6)</sup>	Questionable /Limited Control (Probably greater than 10)	Low	<ul style="list-style-type: none"> <li>• Pond size prohibits odor control</li> <li>• Low noise/enclosable equipment</li> <li>• Covered facility not feasible</li> </ul>
Notes:						
1) Based on Los Osos Wastewater Management Plan Update (Ripley Pacific Team, 2006).						
2) Based on Final Project Report (Montgomery Watson Americas, 2001).						
3) TRI-W site was 8 acres. However, a significant portion of the space is necessary for community amenities. Acreage estimated is for general MBR facility to be consistent with extended aeration MLE and other alternatives.						
4) Processes evaluated are not acceptable for extremely low nitrogen levels required for creek discharge and groundwater injection. A process such as Bardenpho Aeration would be required to achieve sufficient nutrient removal.						
5) Costs are relative to an Extended Aeration MLE facility. Conceptual level costs will be developed as part of the detailed evaluation process.						
6) Estimated acreage not presented in previous studies. Estimate is based on information from the Wallace Group.						



<b>Table 5.19 Effluent Reuse and Disposal Alternatives – Advantages, Disadvantages and Issues</b>					
<b>Disposal/Reuse Alternative</b>	<b>Sufficient Local Capacity for all flow?</b>	<b>Winter Storage Required</b>	<b>Affect on Sea Water Intrusion</b>	<b>Treatment Level</b>	<b>Other Issues</b>
Unrestricted Reuse - Urban	No, 132 ac-ft/yr identified	This alternative can only accommodate small fraction of flow year round	Helps mitigate	Disinfected Tertiary	<ul style="list-style-type: none"> <li>• Can fit future development with purple pipe</li> <li>• Can be used for nitrogen removal</li> </ul>
Unrestricted Reuse - Agriculture	Possibly - depends on local farmers' cooperation and using land outside basin Need 500 - 800 acres	Yes, 500 to 650 ac-ft	Helps mitigate if applied within basin, to a lesser degree than urban reuse	Disinfected Tertiary	<ul style="list-style-type: none"> <li>• Farmers' response to idea has been mixed</li> <li>• Possibility of in-lieu exchange of reuse water for Agricultural well water</li> <li>• Can be used for nitrogen removal</li> </ul>
Percolation Pond	Yes	No	Helps mitigate if located within basin	Disinfected Secondary 23 or 2.2	<ul style="list-style-type: none"> <li>• Must be downwind of residential areas</li> <li>• Area lost to agriculture</li> <li>• Possible loss of biological resources</li> </ul>
Leachfield	Not at Broderson Site (limited to 800,000 gpd with harvest wells, 400,000 without harvest wells). Would require many sites (more than identified in past reports)	No, if sized for all flow	Helps mitigate if located within basin	Disinfected Secondary 23 or 2.2	<ul style="list-style-type: none"> <li>• Harvest wells increase capacity, but harvest water disposal is additional issue</li> <li>• Additional cost to transport effluent to west of town (Broderson site)</li> <li>• Area lost to agriculture</li> <li>• Possible loss of biological/archeological resources</li> </ul>
Sprayfield	Possibly - depends on using land outside basin Need approximately 600 acres	Yes	Does not address intrusion - most sites outside basin	Disinfected Secondary 23	<ul style="list-style-type: none"> <li>• Can be used for nitrogen removal</li> <li>• Changes natural wet/dry seasonal cycle, affecting local species</li> </ul>
Creek Discharge	Yes	No	Does not address intrusion	Disinfected Tertiary	<ul style="list-style-type: none"> <li>• Stringent regulations</li> <li>• Species established due to increased flows will be afforded protections</li> </ul>
Constructed Terminal Wetlands	Yes	No, if sized for all flow	Helps mitigate if located within basin	Disinfected Secondary 23	<ul style="list-style-type: none"> <li>• Could be protected by federal and state laws once established</li> <li>• Provides habitat and recreation area</li> </ul>
Direct Groundwater Injection	Yes	No	Helps mitigate if located within basin	Disinfected Tertiary with Advanced Oxidation and Reverse Osmosis	<ul style="list-style-type: none"> <li>• Stringent regulations</li> <li>• Harvest wells increase capacity, but harvest water disposal is additional issue</li> <li>• Possible disruption of biological/archeological resources</li> </ul>

<b>Table 5.20 Solids Handling Alternatives – Advantages, Disadvantages and Issues</b>	
<b>Solids Treatment</b>	<b>Considerations for Alternative Selection</b>
Sub-Class B Biosolids	<ul style="list-style-type: none"> <li>Least expensive construction cost</li> <li>Future flexibility for inclusion of digestion and/or composting</li> <li>Most expensive hauling costs</li> <li>Relatively low annual O&amp;M costs</li> <li>Most restrictive disposal option</li> <li>Low acreage requirements</li> <li>Odor problems likely if solar drying used</li> </ul>
Digested Class B Biosolids	<ul style="list-style-type: none"> <li>Relatively high construction cost</li> <li>Future flexibility for inclusion of composting</li> <li>Relatively low annual O&amp;M costs</li> <li>Moderate hauling costs</li> <li>Ability to implement cogeneration (if cost effective)</li> </ul>
Heat Dried Class B Biosolids	<ul style="list-style-type: none"> <li>Least expensive hauling costs (except for local recycling)</li> <li>Moderate to high construction cost</li> <li>Moderate annual O&amp;M costs</li> <li>Low acreage requirements</li> <li>Energy intensive process - economics mostly proportional to price of natural gas</li> </ul>
Composted Class B Biosolids	<ul style="list-style-type: none"> <li>Relatively high construction cost</li> <li>High annual O&amp;M costs</li> <li>Less land required as compared to composting Class A</li> <li>Composting requires large amounts of land</li> <li>More restrictive disposal options as compared to Class A</li> </ul>
Composted Class A Biosolids	<ul style="list-style-type: none"> <li>Relatively high construction cost</li> <li>High annual O&amp;M costs</li> <li>Least restrictive disposal option</li> <li>Composting requires large amounts of land</li> </ul>
Digested/ Composted Class A Biosolids	<ul style="list-style-type: none"> <li>Most expensive alternative overall</li> <li>High annual O&amp;M costs</li> <li>Least restrictive disposal option</li> <li>Composting requires large amounts of land</li> <li>Ability to implement cogeneration (if cost effective)</li> </ul>

**Table 5.21 Treatment Facility Site Alternatives – Advantages, Disadvantages and Issues**

Property	APN	Acre-age	Description/ Topography	Flood Hazard	Access to Infrastructure	Agricultural Land	Biological Resources	Archaeological Resources	Hydro-Geology, Soils and Geologic Hazards	Visual Resources	Proximity of Sensitive Receptors	Proximity to Collection Area and Disposal Sites	Other Site-Specific factors	Advantages	Disadvantages
Cemetery Property	074-222-014	48.1	Rectangular parcel that slopes gently downward to the north; westerly boundary slopes downward to the west to a dirt road that provides access to surrounding farming operations; southerly third of the site is used for a cemetery, about 7 acres in the northwest corner is cultivated with row crops, with the remainder fallow; no trees, or other natural features; useable portion of site is about 22 acres.	None	Close to LOVR, with level, unimproved road bordering on the east that intersects LOVR opposite Clark Valley Road  No public water supply  Electricity at LOVR?	Class III  Northwest portion appears irrigated  No LCA contract	No apparent habitat value	Previously identified archaeological site (site 25)	Soils are suitable for building  No landslides  Potential for Los Osos fault	Site is close to LOVR and visible to passing motorists  Gently sloping terrain may help reduce apparent height /prominence of buildings	Cemetery immediately adjacent to the south  Residences on five-acre lots adjacent to the west  Surrounding properties are ag operations	Useable portion of site is within one eighth mile of LOVR  Site appears large enough to support some level of on-site disposal	No known easements or other restrictions	Effective size of the site (about 22 acres) is sufficient to accommodate a wide range of treatment technologies and on-site disposal  Accessible from LOVR via intersection with Clark Valley Road  No apparent habitat value No known private easement constraints  Topography may allow for screening from LOVR  Close to service area  Less prime farm land, no LCA contract  No potential for flooding.	Archaeological resources on property  Close to cemetery and closer to residences to the west  Expansion plans of cemetery are unknown and may affect availability  Los Osos fault may be present  Expansion plans for cemetery unknown
Giacomazzi	067-011-022	37.1	Rectangular parcel that slopes gently downward to the north and east toward an ephemeral drainage that extends along the easterly portion of the site to Warden Lake (offsite); collection of farm-related buildings along the western border; level areas have been cultivated with row crops (irrigation?); numerous tall trees around the buildings and in the drainage channel; useable portion of site is about 20 acres.	None; however, drainage channel conveys seasonal runoff	Close to LOVR, with level, unimproved road bordering on the east that intersects LOVR opposite Clark Valley Road  No public water supply  Electricity at LOVR?	Class III  No LCA contract	Ephemeral drainage and surrounding sloping (uncultivated) areas support native and non-native grasses  Numerous tall trees in channel and adjacent to buildings  Drainage channel may support riparian species	Previously identified archaeological site (site 25) may extend onto this site	Soils are suitable for building  No landslides  Potential for Los Osos fault	Site is about one third mile from LOVR and partially visible to passing motorists  Gently sloping terrain may help reduce apparent height /prominence of buildings	Cemetery is about one quarter mile to the south  Residences on five-acre lots adjacent to the south and west  Surrounding properties are ag operations	Useable portion of site is within one eighth mile of LOVR  Site appears large enough to support some level of on-site disposal	No known easements or other restrictions	Effective size of the site (about 20 acres) is sufficient to accommodate a wide range of treatment technologies and on-site disposal  Accessible from LOVR via intersection with Clark Valley Road  No known private easement constraints  Topography may allow for screening from LOVR  Close to service area  Less prime farm land, no LCA contract  More removed from receptors and visibility from LOVR.	Ephemeral drainages may pose drainage issues with design and may support sensitive biological resources  Archaeological resources may extend onto property from the south  Los Osos fault may be present  Requires access over intervening properties.

**Table 5.21 Treatment Facility Site Alternatives – Advantages, Disadvantages and Issues**

Property	APN	Acre-age	Description/ Topography	Flood Hazard	Access to Infrastructure	Agricultural Land	Biological Resources	Archaeological Resources	Hydro-Geology, Soils and Geologic Hazards	Visual Resources	Proximity of Sensitive Receptors	Proximity to Collection Area and Disposal Sites	Other Site-Specific factors	Advantages	Disadvantages
Andre 2	067-031-011	9.87	Narrow, triangular shaped parcel bordering LOVR; site slopes gently downward to the north; one small building; access provided from adjacent parcel in common ownership; one group of large trees that follows an ephemeral drainage that crosses the northerly portion of the site; useable area of site is about 9 acres, but narrow triangular shape limits development flexibility.	None; however, drainage channel conveys seasonal runoff	Borders LOVR, with level, unimproved road providing access from adjacent property to the west that intersects LOVR east of Clark Valley Road  No public water supply  Electricity at LOVR?	Class III  No LCA contract	Site supports native and non-native grasses  Ephemeral drainage contains numerous tall trees in channel	No known archaeological sites	Soils are suitable for building  No landslides  Potential for Los Osos fault	Site is adjacent to LOVR where the largest developable area is also located  Would be highly visible to passing motorists  Gently sloping terrain may help reduce apparent height /prominence of buildings, but site boundaries narrow to the north	Cemetery is about one quarter mile to the west  Residences on five-acre lots are about one-half mile to the west and to the south  Cluster ag-related buildings (including two residences) on properties to the east  Church is located along LOVR about one-quarter mile to the west  Surrounding properties are ag operations	Most useable portion of site is adjacent to LOVR  Site appears too small and irregularly shaped to support on-site disposal	No known easements or other restrictions	Directly accessible from LOVR  No known private easement constraints  Topography may allow for screening from LOVR  Slightly farther from service area but abuts LOVR  Less prime farm land, no LCA contract  More removed from receptors  No known archaeological resources	Effective size (about 9 acres) and triangular shape may limit the types of treatment and/or disposal technologies.  Useable portion of site is fairly visible from LOVR.  Ephemeral drainage may support some habitat value.  Vehicle speeds on LOVR are high in this area, which would likely require channelization (east-bound left turn lane, west-bound deceleration lane) for vehicle access.
Morosin /FEA	067-171-084	81.2	Irregularly shaped parcel located south of LOVR on the east side of Clark Valley Road at the base of the Irish Hills; southerly half of the site slopes upward into the foothills and is composed of native vegetation; northerly half of site is relatively flat and has been cultivated with row crops; site contains a church with parking and access road on a small knoll at the northerly border of the site; cluster of ag-related buildings located at the base of the foothills; water tank is located about 100 meters upslope from the ag buildings; useable area of site is about 35 acres.	None	Close to LOVR, with level, borders Clark Valley Road, which is a paved, two-lane county road  No public water supply  Electricity?	Class III on the northerly 35 acres  Native soils and vegetation on the remainder  No LCA contract on site  Property adjacent to the west is governed by an LCA contract	Southerly (and un-buildable) portion of the site is composed of native vegetation which may support special status plant and animals species  Cultivated area appears to have no habitat value  No creeks or ephemeral drainages	No known archaeological sites	Soils on level portion of site are suitable for building  No landslides  Potential for Los Osos fault	Site borders Clark Valley Road which provides access to a small number of ranches and farms in the Clark Valley to the south Site is about one-half mile from LOVR and would be at least partially visible to passing motorists Intervening properties are mostly level and cultivated periodically with row crops	Church located on site  Various farming /equestrian operations on surrounding properties of varying size  Residences on five-acre site located about one mile to the west	Useable portion of site is within one half mile of LOVR  Site appears large enough to support some level of on-site disposal	PG&E easement affects westerly 420 feet of site where buildings are prohibited  Property immediately adjacent to the north is subject to a conservation easement	Effective size of the site (about 35 acres) is sufficient to accommodate a wide range of treatment technologies and on-site disposal  Accessible from LOVR via intersection with Clark Valley Road  Less visible from LOVR which may reduce need for screening  Less prime farm land, no LCA contract  More removed from receptors  No known archaeological resources  No flooding issues	Los Osos fault may be present  Somewhat farther to service area than other sites  Church and housing located on property  Sensitive biological resources upslope to the south  PG&E electrical transmission line easement affects the westerly 420 feet of site where buildings would not be allowed.

**Table 5.21 Treatment Facility Site Alternatives – Advantages, Disadvantages and Issues**

Property	APN	Acre-age	Description/ Topography	Flood Hazard	Access to Infrastructure	Agricultural Land	Biological Resources	Archaeological Resources	Hydro-Geology, Soils and Geologic Hazards	Visual Resources	Proximity of Sensitive Receptors	Proximity to Collection Area and Disposal Sites	Other Site-Specific factors	Advantages	Disadvantages
Branin	067-011-020	42.2	Irregularly shaped lot north of LOVR and adjacent to Warden Lake which consists of native wetland and riparian vegetation; site slopes to the north toward Warden lake and contains two ephemeral drainages; useable portion of the site appears to be periodically cultivated and consists of 15 - 25 acres.	Northerly third of site lies within the flood plain of Los Osos Creek /Warden Lake	Close to LOVR, but no apparent improved access  No public water supply  Electricity at LOVR?	Class III on the southerly 25 acres  Native soils and wetland /riparian vegetation on the remainder  No LCA contract on site	Northerly third of the site is composed of native vegetation which may support special status plant and animals species  Cultivated area appears to have no habitat value  Ephemeral drainages appear to have limited habitat	Previously identified archaeological site (site 13) extends onto this site	Soils on level portion of site are suitable for building  May be potential for landslides on slopes leading down to Warden Lake  Potential for Los Osos fault	Site is about two- thirds mile from LOVR and marginally visible to passing motorists  Sloping terrain may help reduce apparent height /prominence of buildings	Cemetery is about two-thirds mile to the south  Residences on five-acre lots located about two-thirds mile to the south and west  Surrounding properties are ag operations	Useable portion of site is about two-thirds mile from LOVR, but appears to have no improved access  Site appears large enough to support some level of on-site disposal	No known easements or other restrictions	Effective size of the site (about 15 - 25 acres) is sufficient to accommodate a wide range of treatment technologies and some on-site disposal  Topography may allow for screening from LOVR  Less prime farm land, no LCA contract  More removed from receptors and visibility from LOVR	Ephemeral drainages may pose drainage issues with design and may support sensitive biological resources  Site drains toward Warden lake, a tributary of Los Osos Creek  Los Osos fault may be present  Northerly portion of site (Warden Lake area) is subject to flooding  Subject to agricultural preserve  Requires access over intervening properties
Gorby	074-225-009	51.7	Irregularly-shaped lot located south of LOVR adjacent to the east side of Los Osos Creek; southerly half of the site slopes upward into the foothills of the Irish Hills and contains native vegetation; the north-westerly portion is level and contains a dwelling and equestrian facilities that include horse paddocks and riding areas. Several ornamental trees occupy the northwesterly portion of the site; level buildable portion of the site is triangular and consists of about 20 – 25 acres.	Site borders Los Osos Creek which is subject to periodic flooding in major storm events  Buildable area appears to be outside the 100 year flood plain	Two lane dirt road provides access to LOVR opposite Lariat Drive  No public water supply  Electricity?	Class I on level area  No LCA contract	Southerly (and un-buildable) portion of the site is composed of native vegetation which may support special status plant and animals species  Los Osos Creek supports mature native riparian vegetation  Equestrian area appears to have no habitat value	Numerous archaeological sites have been identified along Los Osos Creek which have been mapped to this property	Soils on level portion of site are suitable for building  No landslides  Ootential for Los Osos fault	Site is about two- thirds mile from LOVR and marginally visible to passing motorists  Shape of lot and intervening vegetation may help reduce prominence of buildings	Dwellings on five-plus acre lots located immediately to the west of Los Osos Creek  Mobile home park located within one- quarter mile to the northwest  To the north are large-lot subdivisions with ag-related operations  To the east is a church	Useable portion of site is about two-thirds mile from LOVR with access provided by unimproved road which also serves the intervening agricultural operations  Site may be large enough to support some level of on-site disposal, including creek discharge	No known easements or other restrictions	Buildable area of the site (about 6 - 8 acres) is sufficient to accommodate some of the treatment technologies  May be accessible from LOVR  Less visible from LOVR	Los Osos fault may be present  Los Osos creek is subject to flooding  Buildable area is Class I agricultural land and subject to agricultural preserve unless currently developed area used (6 - 8 acres)  Sensitive receptors to the west of creek  Vehicle speeds on LOVR are high in this area, which would likely require channelization (west-bound left turn lane, east-bound deceleration lane) for vehicle access; Creek and upland area support sensitive biological resources  Known unwilling seller

**Table 5.21 Treatment Facility Site Alternatives – Advantages, Disadvantages and Issues**

Property	APN	Acre-age	Description/ Topography	Flood Hazard	Access to Infrastructure	Agricultural Land	Biological Resources	Archaeological Resources	Hydro-Geology, Soils and Geologic Hazards	Visual Resources	Proximity of Sensitive Receptors	Proximity to Collection Area and Disposal Sites	Other Site-Specific factors	Advantages	Disadvantages
Robbins 1	067-031-037	41.1	Mostly rectangular-shaped lot abutting the north side of LOVR east of Clark Valley Road; site contains at least one dwelling and slopes to the north toward Warden Lake; large mature trees surround the farm buildings; site may be used for grazing; buildable portion of the site is about 30 acres.	Northerly portion of site lies within the flood plain of Warden Lake	Site abuts LOVR  No public water supply  Electricity?	Class III on the southerly 30 acres  Native soils and wetland /riparian vegetation on the remainder  No LCA contract on site	Northerly portion of the site is composed of native vegetation /wetlands which may support special status plant and animals species  Fallow area appears to have limited habitat value	No known archaeological sites	Soils on level portion of site are suitable for building  No landslides  Potential for Los Osos fault	Site is adjacent to LOVR, and would be fairly visible to passing motorists  Gently sloping terrain may help reduce apparent height /prominence of buildings	Cemetery and residences on five-acre lots are about one mile to the west  One building (residence) on property to the east  Church is located along south side of LOVR about one-half mile to the west  Surrounding properties are ag operations	Site abuts LOVR and appears large enough to support some level of on-site disposal	No known easements or other restrictions	Effective size of the site (about 30 acres) is sufficient to accommodate a wide range of treatment technologies and on-site disposal  Directly accessible from LOVR  No known private easement constraints or archaeological resources  Topography may allow for screening from LOVR  Less prime farm land, no LCA contract  More removed from receptors and visibility from LOVR	Site drains toward Warden lake, a tributary of Los Osos Creek  Los Osos fault may be present  Northerly portion of site (Warden lake area) is subject to flooding  Vehicle speeds on LOVR are high in this area, which would likely require channelization (east-bound left turn lane, west-bound deceleration lane) for vehicle access  Furthest property east of service area
Robbins 2	067-031-38	43.5	Mostly rectangular-shaped lot abutting the north side of LOVR east of Clark Valley Road; site slopes to the north toward Warden Lake; site may be used for grazing; buildable portion of the site is about 35 acres.	Northerly portion of site lies within the flood plain of Warden Lake	Site abuts LOVR  No public water supply  Electricity?	Class III on the southerly 35 acres; native soils and wetland/riparian vegetation on the remainder  No LCA contract on site	Northerly portion of the site is composed of native vegetation /wetlands which may support special status plant and animals species  Fallow area appears to have limited habitat value	No known archaeological sites	Soils on level portion of site are suitable for building  No landslides  Potential for Los Osos fault	Site is adjacent to LOVR, and would be fairly visible to passing motorists  Gently sloping terrain may help reduce apparent height /prominence of buildings	Cemetery and residences on five-acre lots are about one mile to the west; at least two buildings (residences) on property to the east  Church is located along south side of LOVR about one-half mile to the west  Surrounding properties are ag operations	Site abuts LOVR and appears large enough to support some level of on-site disposal	No known easements or other restrictions	Effective size of the site (about 35 acres) is sufficient to accommodate a wide range of treatment technologies and on-site disposal  Directly accessible from LOVR  No known private easement constraints or archaeological resources  Topography may allow for screening from LOVR  Less prime farm land, no LCA contract  More removed from receptors and visibility from LOVR	Less level than other sites; undulating topography. Site drains toward Warden lake, a tributary of Los Osos Creek  Los Osos fault may be present  Northerly portion of site (Warden lake area) is subject to flooding  Vehicle speeds on LOVR are high in this area, which would likely require channelization (east-bound left turn lane, west-bound deceleration lane) for vehicle access  Second furthest property east of service area

**Table 5.21 Treatment Facility Site Alternatives – Advantages, Disadvantages and Issues**

Property	APN	Acre-age	Description/ Topography	Flood Hazard	Access to Infrastructure	Agricultural Land	Biological Resources	Archaeological Resources	Hydro-Geology, Soils and Geologic Hazards	Visual Resources	Proximity of Sensitive Receptors	Proximity to Collection Area and Disposal Sites	Other Site-Specific factors	Advantages	Disadvantages
Tonini Ranch	067-031-001	645	Irregular shaped ranch land bounded by the north and east by Turri Road; located north of LOVR approximately 2 miles from the urban area; northwesterly portion of the site consists of steeply sloped hills and ravines with native vegetation. southeasterly portion of the site consists of range land and cultivated farm land; existing historic ranch house and out-building near center of parcel. buildable area is approximately 100 acres.	None; however, drainage channel conveys seasonal runoff	Site abuts Turri Road  No public water supply  Electricity?	Class II irrigated on approximately 100 acres.  Williamson Act Contract	Northwesterly portions of the site are composed of native vegetation which may support special status plant and animals species  Cultivated area appears to have no habitat value  Ephemeral drainages appear to have limited habitat	Archaeological sites identified	Soils are suitable for building  No landslides  Potential for Los Osos fault	Site is close to Turri Road and visible to passing motorists; is distant from LOVR with limited visual impact  Gently sloping terrain may help reduce apparent height /prominence of buildings	Surrounding properties are ag operations	Useable portion of site is approximately 2 miles from service area of LOVR  Site is large enough to support large amount of on-site disposal	No known easements or other restrictions in potential building areas	Effective size of the site (over 100 acres) is sufficient to accommodate a wide range of treatment technologies and on-site disposal  Distance from neighbors and sensitive receptors  Accessible from LOVR via Turri Road  No apparent habitat value or known private easement constraints in potential building areas.  Topography and distance allows for screening from LOVR  No potential for flooding.	Archaeological resources on property  Furthest distance from service area  Prime farm land, <u>and</u> LCA contract  Located in scenic viewshed of Turri Road.
Mid-Town (aka Tri-W)	074-229-017	11 +	This site was rough graded for the treatment plant and drainage basin. It generally sloped gently south to north.	None; however, drainage channel conveys seasonal runoff and will require a large drainage basin.	The site is served by water, gas and electricity. The plant would require additional electrical capacity be brought to the site for operation.	Not designated agriculture.	Part of the highly sensitive Los Osos dune sands, home to the endangered Morro shoulderband snail, and several other sensitive species. Many snails were removed from the site during initial construction of the project. Habitat for the snail would easily return given the nature of the sandy soils.	Previously cleared for archaeological resources	Shallow groundwater table (although this varies because of slope); Soils and slopes suitable for construction; Proximate to presumed Strand B of Los Osos fault (disputed by Cleath & Associates)	The site is in town, and adjacent to the heavily traveled LOVR. Views of Morro Rock would be obscured by the treatment facilities. CCC report said net impact was beneficial because views to Morro Rock were opened up.	This site is proximate on three sides to developed land. Residential to the south and west, community facilities to the east. Three churches are nearby.	This site is central to the collection system. Because it lies within the area of collection, it is as efficient a location as would likely be found (i.e. no great advantage to any other site in town). It is as close to the Broderson disposal site as possible without going up the hill to the south.	The site is under the ownership of the LOCSO. Because of previous design, permitting and litigation efforts, it may have a considerably shorter time required to begin construction. Tri-W requires mitigation for ESHA loss.	Accessible from LOVR  No known private easement constraints  Located in center of service area  Previously purchased, permitted and graded for LOCSO project	Effective size of the site (about 10 acres) limits treatment technologies to MBR process  Adjacent to receptors and directly visible from LOVR.  Part of the highly sensitive Los Osos dune sands, home to the endangered Morro shoulderband snail, and several other sensitive species  Significant drainage area requires drainage basin

**CHAPTER 6: SELECTION OF AN ALTERNATIVE**

6.1. INTRODUCTION

The alternatives evaluation process described in Chapter 5, above, includes extensive review of both monetary and non-monetary factors. The evaluation includes engineering feasibility and cost evaluations of a broad range of alternatives, a co-equal environmental analysis, public outreach and input, including a community-wide survey on alternatives, and a formal, public decision making process at the County Planning Commission and Board of Supervisors.

6.2. PRESENT WORTH COST ANALYSIS

The life cycle cost evaluations completed for the engineering review are detailed in the Fine Screening Report and the project Technical Memoranda, with summaries of the cost estimates presented in Section 5.11, above. These estimates cost are the basis for the present worth cost analysis in Table 6.1 through Table 6.6. The “real” federal discount rate of 2.7% was used from Appendix C of OMB Circular A-94 to determine the present worth of operations and maintenance costs for a 30-year life. The operations and maintenance cost estimates include consideration of periodic replacement of short-lived assets.

<b>Table 6.1 Collection System Alternatives Present Worth (\$ Million)</b>								
	Capital		O&M		O&M -- PV		Total -- PV	
	Low	High	Low	High	Low	High	Low	High
Gravity	82.2	89.6	0.48	0.48	9.78	9.78	\$92.0	\$99.4
Low Pressure Grinder Pump	75.6	96.9	1.50	2.00	30.57	40.77	\$106.2	\$137.7
STEP/STEG	65.0	81.4	0.79	0.79	16.10	16.10	\$81.1	\$97.5

The apparent low cost collection system alternatives are gravity or STEP/STEG.



	Capital		O&M		O&M -- PV		Total -- PV	
	Low	High	Low	High	Low	High	Low	High
<i>with Gravity Collection</i>								
Fac Ponds w/Gravity	0.0	0.0	0.04	0.05	0.82	1.02	\$0.8	\$1.0
Sub-Class B w/Gravity	2.6	3.3	0.63	0.66	12.84	13.45	\$15.4	\$16.8
Digested Class B w/Gravity	5.3	6.0	0.63	0.66	12.84	13.45	\$18.1	\$19.5
Heat Dried Class B w/Gravity	5.5	6.2	0.60	0.62	12.23	12.64	\$17.7	\$18.8
Compost Class B w/Gravity	3.6	4.3	0.68	0.71	13.86	14.47	\$17.5	\$18.8
Compost Class A w/Gravity	3.6	4.3	0.62	0.65	12.64	13.25	\$16.2	\$17.5
Digest/Compost Class A w/Gravity	6.3	7.0	0.63	0.66	12.84	13.45	\$19.1	\$20.5
<i>with STEP/STEG Collection</i>								
Fac Ponds w/STEP	0.0	0.0	0.03	0.04	0.61	0.82	\$0.6	\$0.8
Sub-Class B w/STEP	1.4	2.4	0.28	0.38	5.71	7.75	\$7.1	\$10.1
Digested Class B w/STEP	2.8	4.2	0.28	0.38	5.71	7.75	\$8.5	\$11.9
Heat Dried Class B w/STEP	3.0	4.4	0.30	0.42	6.11	8.56	\$9.1	\$13.0
Compost Class B w/STEP	1.9	3.2	0.35	0.48	7.13	9.78	\$9.0	\$13.0
Compost Class A w/STEP	1.9	3.2	0.33	0.46	6.73	9.38	\$8.6	\$12.6
Digest/Compost Class A w/STEP	3.3	5.0	0.33	0.46	6.73	9.38	\$10.0	\$14.4

The apparent low cost solids handling alternative for extended aeration processes is hauling sub-Class B biosolids for off-site disposal.

	Capital		O&M		O&M -- PV		Total -- PV	
	Low	High	Low	High	Low	High	Low	High
<i>with Gravity Collection</i>								
MLE w/Gravity		25.7		0.80		16.31		\$42.0
BIOLAC w/Gravity		20.7		0.80		16.31		\$37.0
SBR w/Gravity		26.5		0.76		15.49		\$42.0
Ox Ditch w/Gravity		23.1		0.79		16.10		\$39.2
Trickling Filter w/Gravity		31.4		1.11		22.62		\$54.0
Fac Ponds w/Gravity		26.1		0.98		19.98		\$46.1
MBR w/Gravity		55.0		0.74		15.08		\$70.1
<i>with STEP/STEG Collection</i>								
MLE w/STEP		26.2		0.92		18.75		\$45.0
BIOLAC w/STEP		21.3		0.90		18.34		\$39.6
SBR w/STEP		26.5		0.94		19.16		\$45.7
Ox Ditch w/STEP		23.6		0.92		18.75		\$42.4
Trickling Filter w/STEP		28.0		1.05		21.40		\$49.4
Fac Ponds w/STEP		24.6		0.98		19.98		\$44.6
MBR w/STEP		58.6		0.99		20.18		\$78.8

The apparent low cost treatment alternative when considering solids handling is Facultative Ponds. Next low cost alternatives are BIOLAC and Oxidation Ditch.

<b>Table 6.4 Effluent Reuse and Disposal Alternatives Present Worth (\$ Millions)</b>								
<b>Individual reuse and disposal components</b>								
	Capital		O&M		O&M -- PV		Total -- PV	
	Low	High	Low	High	Low	High	Low	High
Conservation Program	1.0	5.0	0.00	0.00	0.00	0.00	\$1.0	\$5.0
Storage Ponds (30 – 290 af)	0.400	3.900	0.00	0.00	0.00	0.00	\$0.4	\$3.9
Sprayfields								
Sprayfield Piping	1.210	1.650						
Sprayfield Development	0.020	0.080						
Maintenance Equipment	0.700	2.800						
Land Acquisition	1.800	7.000						
Total Sprayfields	3.730	11.530	0.07	0.28	1.37	5.63	\$5.1	\$17.2
Broderson Leachfields								
Recycled Water Return Main	2.200	2.900						
Recycled Water Pump Station	0.780	1.500						
Leachfield Development	2.367	2.367						
Total Leachfields	5.347	6.767	0.25	0.26	5.10	5.30	\$10.4	\$12.1
Urban and Ag Reuse								
Recycled Water Turn Outs	1.400	2.100						
Recycled Water Return Main	Incl w/ Broderson							
Recycled Water Pump Station	Incl w/ Broderson							
Total Urban and Ag Reuse	1.400	2.100	0.03	0.04	0.69	0.90	\$2.1	\$3.0
<b>Draft EIR Environmentally Superior Alternative</b>								
<b>(\$1M conservation program, sprayfields and Broderson leachfields)</b>								
Conservation Program	1.0	1.0	0.00	0.00	0.00	0.00	\$1.0	\$1.0
Sprayfields (180 acres)	9.70	10.50	0.07	0.28	1.37	5.63	\$11.1	\$16.1
Spray Storage Ponds (50 af)	0.67	0.87	0.00	0.00	0.00	0.00	\$0.7	\$0.9
Broderson Leachfields	5.35	6.77	0.25	0.26	5.10	5.30	\$10.4	\$12.1
VPA 2b Total	\$16.7	\$19.1	\$0.3	\$0.5	\$6.5	\$10.9	\$23.2	\$30.1
<b>Coastal Development Permit Conditioned Alternative</b>								
<b>(\$5M conservation program, Broderson leachfields, urban and ag reuse)</b>								
Conservation Program	5.0	5.0	0.00	0.00	0.00	0.00	\$5.0	\$5.0
Urban and Ag Reuse	1.40	2.10	0.03	0.04	0.69	0.90	\$2.1	\$3.0
Recycled Water Storage (50 af)	0.67	0.87	0.00	0.00	0.00	0.00	\$0.7	\$0.9
Broderson Leachfields	5.35	6.77	0.25	0.26	5.10	5.30	\$10.4	\$12.1
CDP Alternative Total	\$12.4	\$14.7	\$0.284	\$0.304	\$5.8	\$6.2	\$18.2	\$20.9

The apparent low cost combination of effluent reuse and disposal alternatives is the Coastal Development Permit conditioned alternative.

	Capital PV	
	Low	High
Treatment Site Land Acquisition	\$1.0	\$3.0
Env. Permitting/Mitigation	\$1.0	\$2.0
<b>Project Costs</b>		
Administration and Environmental Reports	\$5.0	\$7.0
Design – Gravity Collection System	\$2.5	\$3.0
Design – STEP/STEG Collection System	\$4.5	\$6.0
Design – Treatment Facility	\$2.5	\$3.0
Construction Engineering	\$6.0	\$8.0
Project Soft Costs w/Gravity	\$18.0	\$26.0
Project Soft Costs w/STEP/STEG	\$20.0	\$29.0

	Collection		Treatment		Solids		Effluent		Soft Costs		Total -- PV	
	Low	High	Low	High	Low	High	Low	High	Low	High	Low	High
<i>with Gravity Collection</i>												
Facultative Ponds	92.0	99.4	46.1	46.1	0.8	1.0	18.2	20.9	18.0	26.0	\$175.1	\$193.4
BIOLAC	92.0	99.4	37.0	37.0	15.4	16.8	18.2	20.9	18.0	26.0	\$180.6	\$200.1
Ox Ditch	92.0	99.4	39.2	39.2	15.4	16.8	18.2	20.9	18.0	26.0	\$182.8	\$202.3
<i>with STEP/STEG Collection</i>												
Facultative Ponds	81.1	97.5	44.6	44.6	0.6	0.8	18.2	20.9	20.0	29.0	\$164.5	\$192.8
BIOLAC	81.1	97.5	39.6	39.6	7.1	10.1	18.2	20.9	20.0	29.0	\$166.1	\$197.2
Ox Ditch	81.1	97.5	42.4	42.4	7.1	10.1	18.2	20.9	20.0	29.0	\$168.8	\$199.9

Comparison of the present worth for several project combinations of the apparent low cost alternatives for the collection system (gravity or STEP/STEG) and treatment process (facultative ponds, BIOLAC, or oxidation ditch) demonstrates a close variance in cost estimates of +/-10% of the total estimated project cost. The variance is within the range of uncertainty for the high and low estimates of project costs and the range for each combination overlaps the ranges of the other combinations (see Figure 6.1, below).

Due to the close range of cost estimates for several viable project alternatives, non-monetary factors are also a consideration in selection of alternatives for the collection system and treatment process.

Figure 6.1 Present Worth Comparison for Apparent Low Cost Alternatives



### 6.3. NON-MONETARY FACTORS CONSIDERED

Multiple technology alternatives for the project are within a relative close life-cycle costs range. The ability to interchange collection system and treatment process alternatives results in a wide range of project combinations that are economically feasible. There are, however, non-monetary factors that make some options infeasible and provide direction in selecting an alternative between multiple feasible options.

- a. Treatment Facility Site: The environmental review process included a broad range of potential treatment facility sites. The two most feasible site alternatives, Giacomazzi and Tonini, were co-equally analyzed in the project EIR. The formal decision making process at the County Planning Commission and Board of Supervisors further considered the potential environmental effects of each alternative. Major factors considered in the deliberations include agricultural impacts, visual impacts, and potential for water resources benefits. The decision making process resulted in the selection of the Giacomazzi site alternative and prohibited any development at the Tonini site.

- b. Effluent Reuse and Disposal: No one alternative has the capacity to meet all of the project needs for effluent reuse or disposal, so several combinations of alternatives were considered in the engineering and environmental review process. The project EIR co-equally analyzed several alternatives, and the formal decision making process at the County Planning Commission and Board of Supervisors further considered the potential environmental effects of each alternative. The project was ultimately conditioned to provide tertiary treatment to produce CA Title 22 Recycled Water and to develop a recycled water reuse program that will have the greatest beneficial effect on the basin, measured by the mitigation of sea water intrusion. The reuse program includes the Broderon and Bayridge Estates leachfields and urban and agricultural irrigation reuse. The project also include 50 acre-feet of recycled water storage on approximately 10 acres of the Giacomazzi site. Disposal alternatives and irrigation outside the limits of the groundwater basin are prohibited.
- c. Collection System: Life-cycle cost estimates for gravity and STEP/STEG collection system overlap, and fall within the level of uncertainty of the engineering cost estimate. Recommendation of a gravity collection system included consideration of the following non-monetary factors.
- Environmental analysis: Gravity collection system is the environmentally superior alternative with a significantly reduced greenhouse gas impact and better ability to avoid sensitive archeological areas during construction.
  - Existing design level: A full design of the gravity collection system was completed, with bids received and construction underway, under the LOCS D project. The existing design level provides a high level of confidence in cost estimates and the feasibility of a gravity system. The STEP/STEG system has only been developed to a conceptual plan level. The cost estimates have a higher degree of uncertainty and certain design issues are unresolved, such as whether pump stations will be required. The feasibility of locating and installation of new septic tanks on each individual parcel, some with limited access, is unknown.
  - Schedule considerations: The existing gravity design can be quickly implement by soliciting construction bids after minimal revisions to the bidding documents. Preparation of a STEP/STEG design would likely add one or more years to the project schedule. There are risks of further delay if property owners who oppose placing septic tanks on their properties raise legal challenges or if it is infeasible to locate septic tanks on a large number of properties.
  - Cost escalation: Additional design costs and project delays associated with developing a STEP/STEG design can potentially escalate project costs beyond the currently estimated range, which is comparable to a gravity alternative.
  - Individual property impacts: A STEP/STEG system would disproportionately impact some property owners connection costs. The estimated average cost for homeowners to complete on-lot connection work is between \$2,500 and

- \$7,500. However, individual property owners would likely have costs well over \$10,000, in addition to the project costs charged by the County.
- Overall property impacts: A STEP/STEG system is expected to have less construction impacts in the roadways, with far more impacts on private property. This alternative would disproportionately shift impacts of a public infrastructure project from the public roadway, where impacts are better able to be mitigated, to private property.
  - Community survey results: The Community Advisory Survey, which was conducted in February, 2009, asked property owners and residents which collection system alternative was preferred. An overwhelming 70% preferred a gravity system, even when potential cost savings of a STEP/STEG system were considered.
- d. Treatment Process: Life-cycle cost estimates for facultative ponds and for both extended aeration processes (Biolac and oxidation ditch) overlap, and fall within the level of uncertainty of the engineering cost estimate. The project EIR considered the extended aeration processes as equivalent and completed a co-equal analysis of extended aeration and facultative ponds. The formal decision making process at the County Planning Commission and Board of Supervisors further considered the potential environmental effects of each alternative and effectively eliminated the facultative pond alternative. The approved project allows either extended aeration process. For the purpose of analysis in this report, an oxidation ditch is assumed as a likely alternative to be constructed based on the following non-monetary factors.
- Site constraints: The selection of the Giacomazzi site limits the treatment facility to less than 15 acres after accounting for the recycled water storage ponds and the required setbacks from sensitive resources. Site constraints make facultative ponds infeasible at the Giacomazzi site. A Biolac is feasible on this site, however the smaller footprint of an oxidation ditch increases constructability and flexibility to meet future needs.
  - Greenhouse gas impacts: Biolac and oxidation ditch process have similar greenhouse gas impacts. Facultative ponds have the greatest impact of the three alternatives at 33% greater than Biolac.
  - Effluent total nitrogen limits: The project is expected to have Waste Discharge Requirements with a stringent total nitrogen limit of 7 mg/L. Both extended aeration processes have proven records of consistently meeting this level of denitrification. Facultative ponds are not expected to be able to meet the requirement without additional treatment processes added. This extra level of operational complexity with facultative ponds increases the chance of non-compliance with regulatory discharge requirements.
  - Operational reliability: Facultative ponds may have other reliability compliance issues, in addition to meeting a total nitrogen limit of 7 mg/L. Seasonal variations can lead to increased suspended solids levels or algae problems and upset of thermal layers in the ponds can cause significant odor incidents. Biolac and oxidation ditch are relatively similar in reliability,

however the blower and diffuser system with Biolac is a potential maintenance issue not present with an oxidation ditch. Several municipal oxidation ditches of similar capacity are already in operation or planned in San Luis Obispo County, increasing the ability to recruit operators familiar with the process.

- Construction costs: The aeration basins with Biolac are constructed as lined earth ponds, compared to reinforced concrete with an oxidation ditch. At this time, cost estimates for the two processes are relatively close and are outweighed by non-monetary factors. Market volatility for construction materials must be monitored as the project moves toward the design phase to confirm the preliminary cost estimates.
- e. Biosolids Handling: Hauling sub-Class B biosolids to a local disposal or recycling facility is the lowest life-cycle cost alternative and is recommended for the project. The current regulatory and economic climate is favorable for this alternative, and the option for further treatment is not precluded from being added at some future date, if regulations change. The facilities required for this alternative are a biosolids storage tank, a thickening process, a mechanical dewatering process, and loading station. All of these facilities would likely be used as part of a digesting or composting process to produce classified biosolids, if required in the future.

---

## CHAPTER 7: PROPOSED PROJECT (RECOMMENDED ALTERNATIVE)

### 7.1. INTRODUCTION

The recommended alternative is the project description approved by the County Planning Commission and Board of Supervisors in 2009 through the formal environmental review process. The approved project is a combination of the many alternatives evaluated in the engineering and environmental review processes. The project consists of a gravity collection system for the entire service area, extended aeration secondary treatment process with tertiary filtration and disinfection at the Giacomazzi site, sanitary disposal of dewatered biosolids, and recycled water reuse program through sub-surface leachfields and unrestricted irrigation.

### 7.2. PROJECT DESIGN

- a. Collection System Layout and Pumping Stations: A full collection system design was completed by the Los Osos CSD in 2004, prior to their cessation of the project and the passage of AB 2701. This design is largely the basis for the proposed project, with the exception of changes required to convey wastewater to a new treatment plant site at the eastern edge of the community. These changes consist of an additional pumping station at the Mid-Town site and a force main from this site to the treatment facility. Collection system and pumping station details are provided in Table 7.1, below. The layout of the collection system and pumping stations is provided in Figure 5.1 (Project Diagram).
- b. Treatment Facility: The treatment facility will be located at the Giacomazzi site, on the eastern edge of the community. The site is 38 acres, with approximately 30 acres of useable area after avoidance and buffers for sensitive resources. The site will contain all treatment and related facilities including administration and maintenance buildings, solids processing, storm water and emergency overflow retention, recycled water storage ponds, and recycled water pump station.

The treatment facility will be design for an average daily flow of 1.2 MGD and will consist of the following:

- Headworks and bar screens covered for odor control
- Extended aeration secondary treatment process (oxidation ditch assumed) designed to meet total nitrogen limit of 7 mg/L
- Secondary clarifiers
- Return/waste activated sludge pump station
- Tertiary filtration with ultraviolet disinfection designed to meet California Title 22 standards for tertiary recycled water
- Mechanical sludge dewatering (belt filter press or screw press) enclosed in a building for odor control
- Recycled water storage ponds and pump station



The layout of the treatment facility and recycled water storage ponds is provided in Figure 7.1. Architectural renderings of the proposed building design are provided in Figure 7.2 and Figure 7.3.

<b>Table 7.1 Collection System Information</b>				
<b>Pipelines</b>				
<b>Pipe Diameter</b>	<b>Depth: 0-8 ft</b>	<b>Depth: 9-12 ft</b>	<b>Depth: 13-15 ft</b>	<b>Depth: 16-18 ft</b>
8-inch	159,256 ft	45,849 ft	2,240 ft	80 ft
10-inch	0	1,190 ft	1,300 ft	0
12-inch	0	2,413 ft	654 ft	654 ft
15-inch	0	3,561 ft	709 ft	0
18-inch	0	860 ft	600 ft	0
<b>Pump Stations</b>				
<b>Name &amp; Type</b>	<b>Location</b>	<b>Peak Hour Wet Weather Flowrate (gpm)</b>	<b>Pump HP (each)</b>	<b>Stand-by Power</b>
Mid-Town Triplex	LOVR & Palisades	2,800	75	Yes, remote location
West Paso Triplex	3 <sup>rd</sup> & Paso Robles Ave.	1,900	60	Yes, remote location
Lupine Triplex	Lupine & Donna	1,000	30	Yes
Baywood Duplex	2 <sup>nd</sup> St.	310	5	Yes, remote location
East Ysabel Duplex	Santa Ysabel & So. Bay Blvd	170	10	Yes
East Paso Duplex	18 <sup>th</sup> & Paso Robles Ave.	330	8	Yes
Mountain View Duplex	Santa Ynez & Mt. View	130	5	Yes
Solano Duplex	Solano & Butte	240	20	Yes
Sunny Oaks Duplex	LOVR @ Sunny Oaks	120	3	Yes
Pocket PS (13 each)	Various	7 – 34	1	No (2 – 7 hours storage)

Figure 7.1 Treatment Facility Layout

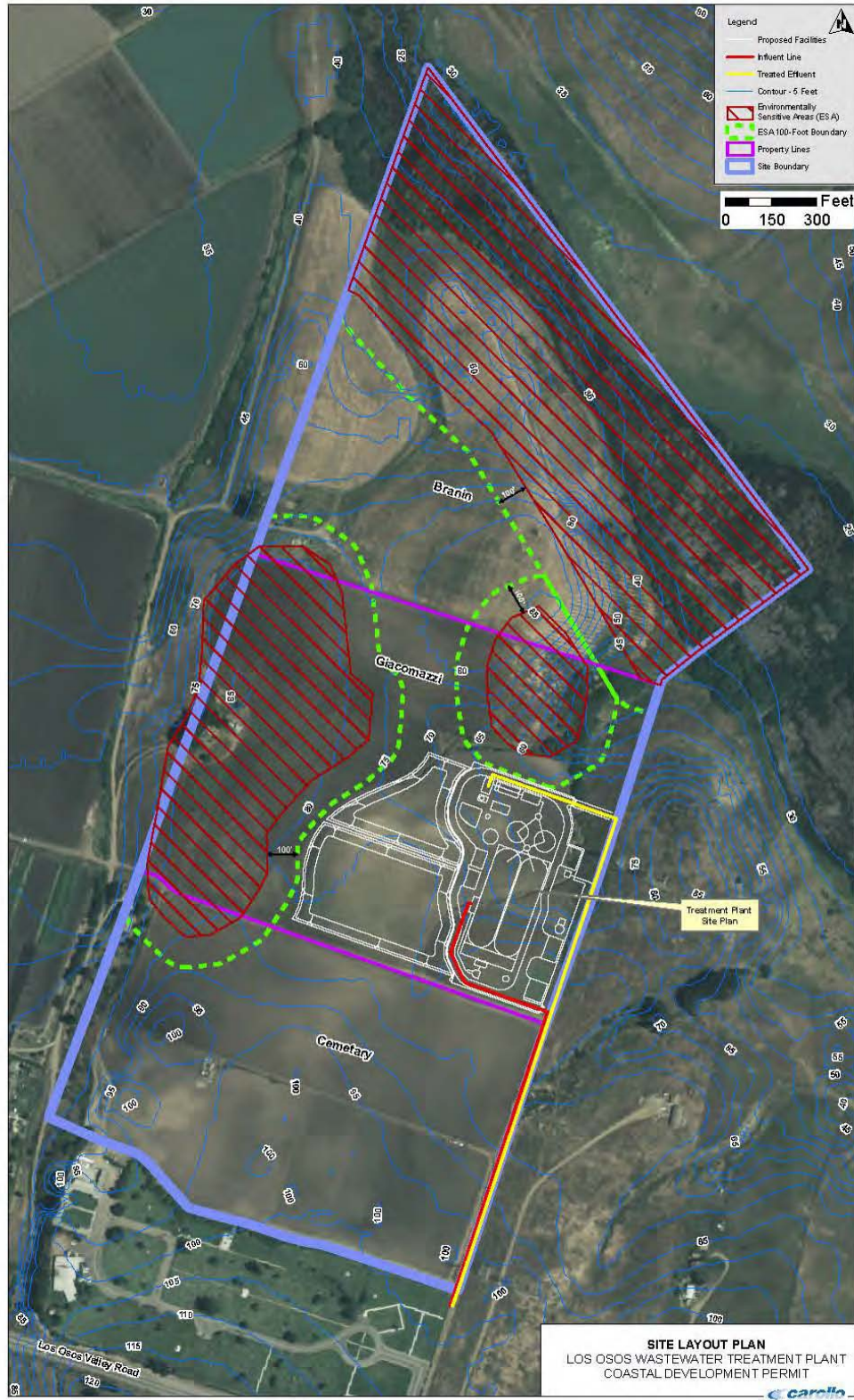

Figure 7.2 Treatment Facility Administration Building Architectural Rendering



PERSPECTIVE

LOS OSOS WASTEWATER TREATMENT FACILITY  
ADMINISTRATION BUILDING

STEVEN D. PULTS & ASSOCIATES, LLC  
SAN LUIS OBISPO, CA

COUNTY OF  
SAN LUIS OBISPO, CA

Figure 7.3 Treatment Facility Maintenance Building Architectural Rendering



PERSPECTIVE

LOS OSOS WASTEWATER TREATMENT FACILITY  
MAINTENANCE BUILDING

STEVEN D. PULTS & ASSOCIATES, LLC  
SAN LUIS OBISPO, CA

COUNTY OF  
SAN LUIS OBISPO, CA

- c. Recycled Water Reuse: Recycled wastewater will be reused within the community or surrounding agricultural land overlying the groundwater basin according the approved conditions of the Coastal Development Permit. It will either be discharged through leachfields or directly reused for urban or agricultural irrigation. The reuse program will consist of the following:
- 50 acre-feet of storage at the treatment plant site
  - A recycled water main running from the treatment plant site, through the adjacent agricultural area, to reuse sites within the community
  - 8 acres of leachfields at the Broderson site, with an annual capacity of 450 acre-feet
  - Utilize one acre of existing leachfields in the Bayridge Estates sub-division with an annual capacity of 33 acre-feet
  - Provide approximately 130 acre-feet of recycled water to Los Osos schools, parks, golf course, and cemetery
  - Provide recycled water main turn-outs to adjacent farmlands and develop reuse agreements for approximately 100 to 200 acre-feet per year

The approved reuse program includes capacity to meet the flows from existing development that will connect to the system at project start-up. Connection of additional users, from currently undeveloped property, is specifically prohibited in the Coastal Development Permit, until certain conditions are met. These conditions include the requirement to develop a habitat conservation plan for Los Osos, develop a water management plan, and update the Local Coastal Plan to incorporate the habitat and water plans. Reuse capacity for the additional flows associated with new development is not necessary at project start-up, due to these conditions. The Coastal permit conditions effectively require a water management plan to identify the most beneficial reuse alternatives for the additional flows associated with new development, prior to any new connections to the system. The layout of the recycled water reuse sites is provided in Figure 5.1 (Project Diagram).

- d. Water Conservation Program: A water conservation program will be implemented with residential and commercial fixture retrofits, appliance rebates, education, and water efficiency audits. The goal of the conservation program is to reduce indoor use by over 25% to 50 gallons per capita per day. The water conservation program will result in decreased demand on system facilities such as pump stations and treatment works, increase the operating life of the facilities, and increase operational flexibility.

7.3. TOTAL PROJECT COST ESTIMATE

Cost estimates for individual components are presented in Section 5.11. Total project cost estimate for the proposed project is summarized below. The total capital project cost expected to be financed with a combination of USDA and State Revolving Fund (SRF) financing is estimated at \$173.5 M, which includes anticipated finance charges and excludes homeowner financed on-lot costs.

<b>Table 7.2 Total Project Capital Cost Estimate</b>		
	<b>Average Estimate (\$ M)</b>	<b>Notes</b>
<b>Collection System</b>		1
Mobilization/Demobilization	\$3.9	
Gravity Sewers and Force Mains	\$29.2	
Manholes	\$4.5	
Shoring and Dewatering	\$5.1	
Duplex Pump Stations	\$2.6	
Triplex Pump Stations	\$1.2	
Pocket Pump Stations	\$2.4	
Standby Power Facilities	\$2.5	
Misc. Facilities	\$3.3	
Laterals in Right-of-Way	\$9.3	
Road Restoration	\$5.2	
Homeowner On-Lot Facilities	\$13.3	2
Out-of-Town Conveyance	\$3.4	3
<b>Total Collection System</b>	<b>\$85.7</b>	
<b>Treatment Process</b>		
Secondary Process	\$19.6	4
Tertiary Filtration/Disinfection	\$3.5	5
<b>Total Treatment Process</b>	<b>\$23.1</b>	
<b>Solids Processing</b>		
Thickening	\$1.0	6
Mechanical Dewatering	\$2.0	7
<b>Total Solids Processing</b>	<b>\$3.0</b>	
<b>Recycled Water Reuse</b>		
Water Conservation Program	\$0.0	8
Broderson Pipe and Leachfield	\$6.1	
Recycled Water Turn-outs	\$1.8	9
Recycled Water Storage (50 af)	\$0.8	
<b>Total Recycled Water Reuse</b>	<b>\$8.6</b>	
<b>Sub-Total Construction</b>	<b>\$120.3</b>	
10% Construction Contingency	\$10.7	10
<b>Total Construction Costs</b>	<b>\$131.0</b>	
Cost Escalation (18.0%) to Mid-Point of Construction	\$23.6	11

<b>Table 7.2 Total Project Capital Cost Estimate</b>		
	<b>Average Estimate (\$ M)</b>	<b>Notes</b>
<b>Project Soft Costs</b>		
Water Conservation Program	\$5.0	12
Admin/Environmental Reports	\$6.0	
Land - Treatment Site	\$2.0	
Environmental Permits/Mitigation	\$1.5	
Design-Collection System	\$2.7	
Design-Treatment Facility	\$2.8	
Construction Management	\$7.0	
<b>Total Project Soft Costs</b>	<b>\$27.0</b>	
<b>Total Project Costs</b>	<b>\$181.6</b>	13
<b>Financing Costs</b>		
Conditioned Repayment of LOSCD Default on SRF Loan	\$6.5	
Interest and Issuance Charges – Interim Financing	\$1.0	
<b>Total Capital Project Costs</b>	<b>\$189.1</b>	13
<p>(1) Collection System estimates from Fine Screening Report (FSR), Table 3.17, except as noted.            (2) Homeowner On-Lot Facilities not eligible for project financing; owner financed.            (3) Conveyance estimate from Conveyance Tech Memo, Table 7, with no micro-tunneling.            (4) Secondary treatment estimate from FSR, Tables 4.9 &amp; 4.19.            (5) Tertiary treatment estimate from FSR, Section 4.8 for full flow.            (6) Thickening estimate from FSR, Table 5.3.            (7) Dewatering estimate from FSR, Table 5.5.            (8) Included in Project Soft Costs; no escalation on Water Conservation Program.            (9) Average of range for estimated 10,000 to 15,000 linear feet of recycled water pipeline at \$143/lf.            (10) Assume 10% construction contingency, less Homeowner On-Lot Facilities.            (11) FSR, Appendix C estimated construction cost escalation at 5%, per year, from April 2007 to June 2011, the estimated mid-point of construction. The estimated construction cost escalation has been revised to reflect recent economic developments and project delays. The Engineering News Report Construction Cost Index 20-Cities Average for February, 2010 is 8671 (10.05% increase over April, 2007). Adding an assumed 3% annual escalation from February, 2010 to an assumed mid-point of construction in June, 2012, the total escalation is 18.0%.            (12) Water Conservation Program budget of \$5 M required per project Coastal Development Permit conditions.            (13) Includes \$15.6 M (\$13.3 M + 18% escalation) for Homeowner On-Lot Facilities.</p>		

7.4. ANNUAL OPERATION BUDGET

The proposed project will provide wastewater collection and treatment services to a community that is entirely on septic systems. The development and operation of this major infrastructure project will require a variety of funding sources. In October, 2007, property assessments were established for currently developed properties that are equivalent to \$24,941 per single family dwelling unit for a total of \$126,722,296. Additional assessments for vacant properties are planned, subject to a second assessment vote under California Proposition 218. The assessment district for undeveloped properties will follow the same formula as for developed properties and provide an additional \$27,721,704. The total property assessments of \$154,444,000 will fund capital project costs that are considered “special benefits” under California assessment law. Other capital project costs which are not considered “special benefits” total approximately \$12 million, plus homeowner financed on-lot facilities. The income for these non-special benefit capital costs, operations and maintenance costs, and reserve funds will be developed through user charges.

- a. Income – Total Revenue Requirements and Estimated Charges per EDU: The total annual revenue requirements for debt service, reserves, and O&M costs are allocated between property assessments and user charges. Property assessment charges are assumed to be charged to all developed and undeveloped property in the assessment district. User charges are assumed to be charged only to currently developed property within the service area. All USDA financing is assumed to be allocated to the assessment charges. The SRF loan program will finance the remaining capital costs, which will be repaid through a combination of property assessments and user charges. All short-lived asset reserves and O&M costs are allocated to user charges.

<b>Table 7.3 Estimated Total Revenue Requirements</b>			
<b>Category</b>	<b>Total Annual Costs</b>	<b>Allocated to Assessments</b>	<b>Allocated to User Charges</b>
Debt Service (USDA Loan)	\$4,179,165	\$4,179,165	\$0
Debt Service Reserve (USDA Loan)	\$0	\$0	\$0
Debt Service (SRF)	\$6,284,669	\$5,003,806	\$1,280,863
Debt Service Reserve (SRF)	\$128,086	\$0	\$128,086
Short-Lived Asset Reserve	\$200,000	\$0	\$200,000
O&M	\$2,370,000	\$0	\$2,370,000
<b>Annual Revenue Required</b>	<b>\$13,161,920</b>	<b>\$9,182,971</b>	<b>\$3,978,949</b>



<b>Table 7.4 Example Total Monthly Costs by User Group</b>				
<b>Example User Group</b>	<b>Assessment Charge Per Unit</b>	<b>User Charge Per Unit</b>	<b>On-Lot Costs Per Unit</b>	<b>Total Costs Per Unit</b>
Single Family Residence	\$123.58	\$60.87	\$47.32	\$231.77
Multi Family, 4 unit apartment or condo	\$86.99	\$45.66	\$11.83	\$144.48
Mobile Home Park, 125 unit	\$33.62	\$30.45	\$0.38	\$64.45
Single Family, Bayridge Estates/Vista De Oro Tracts	\$67.06	\$60.87	\$0.65	\$128.58
Low-Load, Non-Resid, 5 tentants, 50k ft <sup>2</sup>	\$114.47	\$67.48	\$9.46	\$191.42
Med-Load, Non-Resid, two tentant, 15k ft <sup>2</sup>	\$89.84	\$81.84	\$23.66	\$195.33
High-Load, Non-Resid, one tenant, 20k ft <sup>2</sup>	\$235.78	\$310.78	\$47.32	\$593.88
Special User (septage)	\$0.00	\$1.95	\$0.00	\$1.95

b. Equivalent Dwelling Unit Calculations:

Property Assessments for Special Benefits Portion of Capital Costs: The project Assessment Engineer’s Report for the project assessment district developed the calculations for “special benefit” units for various components of the project. The benefit unit calculation allocates costs to each equivalent dwelling unit (EDU) based on infrastructure needed and estimated wastewater generation. The tables below summarize the calculations in the Assessment Engineer’s Report. Benefit units are apportioned to several use categories and special cases, based on wastewater generation estimates, and allocated to each project component. The actual assessment charge for each property, as detailed in the Assessment Engineer’s Report, will be the basis for all assessment related charges. The total property assessments for all “special benefits” are assumed to be \$154,444,000.

Use Category	Benefit Units (BU)				
	Lateral	Collector	Trunk	Treatment & Disposal	Common Facility
Residential Single Family	1	1	1	1	1
Residential Multi-Family	1	0.75/unit	0.75/unit	0.75/unit	0.75/unit
Mobile Homes	1	0	0.5/unit	0.5/unit	0.5/unit
Vista del Oro & Bayridge Estates tracts	0	0	1	1	1
Commercial / Non-Residential	1	1/10,000-sf	1/10,000-sf	1/10,000-sf	1/10,000-sf

Special Cases were analyzed individually, including condominiums, mobile home parks, schools, churches, and public facilities.

Component	Special Benefit Assessment Cost	BU's for Build-Out Parcels	Cost per BU	Component % of Total Cost	Weighted Average BU's - Build-Out Parcels
Lateral	\$10,956,000	4769	\$2,297.34	9%	439.3
Collector	\$52,341,045	5745.47	\$9,109.97	37%	2098.6
Trunk	\$23,105,955	6734.72	\$3,430.87	14%	926.4
Treatment	\$49,551,000	6734.72	\$7,357.54	29%	1986.7
Common	\$18,490,000	6734.72	\$2,745.47	11%	741.3
<b>Totals</b>	<b>\$154,444,000</b>		<b>\$24,941.19</b>	<b>100%</b>	<b>6192.3</b>

Example User Group	Total Assessment	Total Monthly Charge	Per Unit Monthly Charge
Single Family Residence	\$24,941.19	\$123.58	\$123.58
Multi Family, 4 unit apartment or condo	\$70,228.89	\$347.97	\$86.99
Mobile Home Park, 125 unit	\$848,164.84	\$4,202.53	\$33.62
Single Family, Bayridge Estates/Vista De Oro Tracts	\$13,533.88	\$67.06	\$67.06
Non-Resid, 5 tentants, 50k ft <sup>2</sup>	\$115,516.59	\$572.37	\$114.47
Non-Resid, two tentant, 15k ft <sup>2</sup>	\$36,263.12	\$179.68	\$89.84
Non-Resid, one tenant, 20k ft <sup>2</sup>	\$47,585.04	\$235.78	\$235.78

User Charges for General Benefit Portion of Capital Costs and O&M Costs: The Project Revenue Analysis, submitted for the USDA Rural Development program application, contains revenue tables in the Exhibits. EDU calculations have been developed for residential and non-residential user groups based on wastewater generation and loading estimates for the purpose of allocating project user charges. The estimates are based on current development only, which will be the start-up rate base for project user charges.

User Group	Number of Accounts	EDU's/Account	Total EDU's
Single Family	4289	1.00	4289
Multi Family	809	0.75	607
Mobile Home	542	0.50	271
Low-load Non-Resid	147	1.11	163
Med-load Non-Resid	5	1.34	7
High-load Non-Resid	17	5.08	86
Special User (septage)	749	0.03	24
<b>Totals</b>	<b>6,558</b>		<b>5447</b>

User Group	# of Accts	Variable O M & R	Fixed O M & R	Capital Replace. Fund	Debt Service	Debt Service Reserve	Total Annual Revenue	Avg. Monthly Revenue
Single Family	4289	\$446,099	\$1,416,592	\$158,306	\$1,011,132	\$100,665	\$3,132,794	\$60.87
Multi Family	809	63,115	200,421	22,397	143,056	14,242	443,232	45.66
Mobile Home	542	28,201	89,553	10,008	63,921	6,364	198,047	30.45
Low-load Non-Resid	147	16,950	53,826	6,015	38,420	3,825	119,037	67.48
Med-load Non-Resid	5	633	2,462	204	1,444	167	4,910	81.84
High-load Non-Resid	17	8,008	32,385	2,521	18,299	2,186	63,400	310.78
Special User (septage)	749	1,994	9,759	549	4,591	637	17,530	1.95
<b>Totals</b>	<b>6558</b>	<b>\$565,000</b>	<b>\$1,805,000</b>	<b>\$200,000</b>	<b>\$1,280,863</b>	<b>\$128,086</b>	<b>\$3,978,949</b>	<b>\$50.56</b>

- c. Operations and Maintenance (O&M) Costs: The following tables show estimated O&M costs for labor, power, and equipment maintenance. Total project O&M costs are summarized in Table 7.13.

Item	Units	Quantity	Unit Price (\$)	Annual O&M (\$)
Labor	Hrs/year	4,160 <sup>(1)</sup>	40 <sup>(2)</sup>	170,000
Power	Kwh/year	500,000 <sup>(3)</sup>	0.12 <sup>(2)</sup>	60,000
Equipment Maintenance				200,000
<b>TOTAL O&amp;M COST<sup>(4)</sup></b>				<b>\$430,000</b>

Notes:  
 (1) Based on 2 full-time employees and 2,080 hours per year.  
 (2) From Basis of Cost Evaluation Technical Memorandum.  
 (3) Based on energy required to convey 1.4 mgd to an out-of-town treatment facility.  
 (4) Septic hauling costs for homes outside of the Prohibition Zone are not included.

Annual O&M costs for each of the treatment alternatives were estimated for the following categories based on BioTran<sup>®</sup> modeling of unit process requirements.

- Labor
- Power
- Maintenance/ Equipment Replacement
- Allowances—Includes chemicals, screenings and grit disposal
- Unit cost curves for tertiary treatment per MGD
- 

Item	Units	Quantity	Unit Price (\$)	Annual O&M (\$)
Labor	Hrs/year	5,200	60 <sup>(1)</sup>	310,000
Power	Kwh/year	900,000	0.12 <sup>(2)</sup>	110,000
Equipment Maintenance				75,000
Allowances				50,000
Tertiary Filter O&M				100,000
<b>TOTAL O&amp;M COST</b>				<b>\$645,000</b>

Notes:  
 (1) Labor costs are based on an average \$60 hourly rate, including direct and indirect costs.  
 (2) Power costs based on \$0.12 per kWh electrical rate.

The cost basis for biosolids processing was developed in the Fine Screening Report and is based on master planning efforts for a similar sized facility in Morro Bay, CA.

Item	Annual O&M (\$)
Thickening <sup>(1)</sup>	170,000
Mechanical Dewatering <sup>(1)</sup>	280,000
Hauling <sup>(2) (3)</sup>	190,000
<b>TOTAL O&amp;M COST</b>	<b>\$640,000</b>
Notes:	
(1) Includes labor, power, chemicals, and maintenance.	
(2) Based on an average solids volume from primary and secondary treatment process of 4,000 pounds per day (dry weight) with dewatering to 18% solids.	
(3) Based on a hauling and tipping fee at San Joaquin Composting facility of \$42 per ton for Class B biosolids and \$46 per ton for Sub-Class B biosolids.	

The cost basis for recycled water reuse was developed in the Fine Screening Report, Appendix A, and is based on estimated energy costs for delivering recycled water to reuse locations and labor costs for routine maintenance.

Item	Units	Quantity	Unit Price (\$)	Annual O&M (\$)
Leachfield Labor	Hrs/year	1,500	60 <sup>(1)</sup>	90,000
Leachfield Power	Kwh/year	1,375,000	0.12 <sup>(2)</sup>	165,000
Reuse Irrigation Power	Kwh/year	333,000	0.12 <sup>(2)</sup>	40,000
<b>TOTAL O&amp;M COST</b>				<b>\$295,000</b>
Notes:				
(1) Labor costs are based on an average \$60 hourly rate, including direct and indirect costs.				
(2) Power costs based on \$0.12 per kWh electrical rate.				
(3) Cost estimates summarized from Table A2 of Fine Screening Report (Carollo, August, 2007)				

<b>Table 7.14 Summary of Total Project Annual O&amp;M Cost Estimate</b>	
	<b>Annual O&amp;M</b>
Collection System	
• Labor	\$170,000
• Power	\$60,000
• Equipment Maintenance	\$200,000
Treatment Process	
• Labor	\$310,000
• Power	\$110,000
• Equipment Maintenance	\$75,000
• Allowances	\$50,000
• Tertiary Filter O&M	\$100,000
Solids Handling	
• Thickening & Dewatering	\$450,000
• Hauling	\$190,000
Recycled Water Reuse	
• Leachfield Energy	\$165,000
• Leachfield Labor	\$90,000
• Reuse Irrigation Energy	\$40,000
Miscellaneous Costs	
• Habitat Mitigation	\$10,000
• County Overhead and Billing	\$300,000
• Contingency/Operating Reserves	\$50,000
<b>Total Annual O&amp;M Costs</b>	<b>\$2,370,000</b>

- d. Debt Repayments: The County does not have any existing wastewater facilities, or existing debt, for the community of Los Osos. Total project capital costs are assumed to be financed through the USDA Rural Utility Service program and the US EPA State Revolving Fund program. Repayment of project financing will be a combination of property assessments and user charges.

Collection of both the property assessments and user charges portions of the revenue requirements will be through the County's semi-annual property tax bills. Collection of property assessments on the property tax bills is authorized by the completed Proposition 218 proceedings. User charges are also authorized to be collected on the property tax bills pursuant to CA Health and Safety Code Sections 5470-5473.11 and County Code Section 3.22.

Any delinquent project accounts for either the property assessments or user charges will be paid by the County under the *Teeter Plan*, as provided in the CA Revenue and Taxation Code Section 4701 *et seq.* Under the Teeter Plan, the County annually distributes 100% of the secured tax revenue due to the project on a cash basis. The County is then responsible for collection of delinquent charges, plus interest and penalties, through subsequent collections.

There are 4,281 existing septic systems serving individual or multiple users that must be abandoned and the users connected to the collection system laterals in the right-of-way. Individual property owners are responsible for these improvements and costs related to all work that is necessary on their private property to abandon existing septic systems. Costs are expected to vary greatly by individual property, and are estimated in the Fine Screening Report from less than \$1,500 to \$10,000 or more. The average cost per property, or septic system abandonment, is estimated at \$3,650 and assumed to be owner financed with a home equity line of credit or other commercial loan. Financing costs would average \$47.32 per month, at an assumed 9.0% interest rate for a 10 year term. Debt service for these costs are the responsibility of each property owner and their individual lender and are not included in the estimated project revenue requirements.

	<b>Term (yrs)</b>	<b>Rate</b>	<b>Capital</b>	<b>Annual Debt Service</b>
USDA Loan	40 <sup>1</sup>	4.000%	\$80,000,000	\$4,041,879
SRF Loan	20	3.000%	\$93,500,000	\$6,284,669
Homeowner financed on-lot costs	10	9.000%	\$15,600,000	\$2,430,793
<b>Total Capital Financing</b>			\$189,100,000	\$12,894,627
1: USDA loan 40 year term assumes interest only payments during 3 year construction period, then principal and interest amortized over remaining 37 years.				

e. Reserves:

- (1) **Debt Service Reserve:** It is assumed that all assessment backed debt, which will be collected on the property tax bills and paid by the County under the Teeter Plan will not be subject to requirements for a debt service reserve. Debt for capital costs that are general benefits and collected through user charges will require a 10% debt service reserve on the annual payment obligation for 10 years. Capital costs allocated to user charges will be financed with an SRF loan and the debt service reserve amount is shown in the estimated total revenue requirements on Table 7.3.
- (2) **Short-Lived Asset Reserve:** A schedule of replacement frequency and costs for short-lived assets in the collection system, treatment facility and recycled water distribution is presented below. The assumed annual reserve fund for all short-lived assets is \$200,000.

<b>Table 7.16 Short-Lived Asset Reserve Schedule</b>										
Facility/Components		Overall Life Span	Service Age			Type of Service Required	Equipment Cost	Service Age		
			5	10	15			5	10	15
			Total	Total	Total			Total	Total	Total
<b>Pocket Pump Stations</b>										
04A										
	Grinder Pump No. 1	15		X		Unit Replacement	\$2,000	\$0	\$2,000	\$0
	Grinder Pump No. 2	15			X	Unit Replacement	\$2,000	\$0	\$0	\$2,000
	Grinder Pump No. 3	15			X	Unit Replacement	\$2,000	\$0	\$0	\$2,000
07A										
	Grinder Pump No. 1	15		X		Unit Replacement	\$2,000	\$0	\$2,000	\$0
	Grinder Pump No. 2	15			X	Unit Replacement	\$2,000	\$0	\$0	\$2,000
08A										
	Grinder Pump No. 1	15		X		Unit Replacement	\$2,000	\$0	\$2,000	\$0
	Grinder Pump No. 2	15			X	Unit Replacement	\$2,000	\$0	\$0	\$2,000
09A										
	Grinder Pump No. 1	15		X		Unit Replacement	\$2,000	\$0	\$2,000	\$0
	Grinder Pump No. 2	15			X	Unit Replacement	\$2,000	\$0	\$0	\$2,000
	Grinder Pump No. 3	15			X	Unit Replacement	\$2,000	\$0	\$0	\$2,000
09B										
	Grinder Pump No. 1	15		X		Unit Replacement	\$2,000	\$0	\$2,000	\$0
	Grinder Pump No. 2	15			X	Unit Replacement	\$2,000	\$0	\$0	\$2,000
09C										
	Grinder Pump No. 1	15		X		Unit Replacement	\$2,000	\$0	\$2,000	\$0
	Grinder Pump No. 2	15			X	Unit Replacement	\$2,000	\$0	\$0	\$2,000
10A										
	Grinder Pump No. 1	15		X		Unit Replacement	\$2,000	\$0	\$2,000	\$0
	Grinder Pump No. 2	15			X	Unit Replacement	\$2,000	\$0	\$0	\$2,000



Facility/Components	Overall Life Span	Service Age			Type of Service Required	Equipment Cost	Service Age		
		5	10	15			5	10	15
		Total	Total	Total			Total	Total	Total
11A									
Grinder Pump No. 1	15		X		Unit Replacement	\$2,000	\$0	\$2,000	\$0
Grinder Pump No. 2	15			X	Unit Replacement	\$2,000	\$0	\$0	\$2,000
12A									
Grinder Pump No. 1	15		X		Unit Replacement	\$2,000	\$0	\$2,000	\$0
Grinder Pump No. 2	15			X	Unit Replacement	\$2,000	\$0	\$0	\$2,000
13A									
Grinder Pump No. 1	15		X		Unit Replacement	\$2,000	\$0	\$2,000	\$0
Grinder Pump No. 2	15			X	Unit Replacement	\$2,000	\$0	\$0	\$2,000
13B									
Grinder Pump No. 1	15		X		Unit Replacement	\$2,000	\$0	\$2,000	\$0
Grinder Pump No. 2	15			X	Unit Replacement	\$2,000	\$0	\$0	\$2,000
15B									
Grinder Pump No. 1	15		X		Unit Replacement	\$2,000	\$0	\$2,000	\$0
Grinder Pump No. 2	15			X	Unit Replacement	\$2,000	\$0	\$0	\$2,000
Palisades									
Grinder Pump No. 1	15		X		Unit Replacement	\$2,000	\$0	\$2,000	\$0
Grinder Pump No. 2	15			X	Unit Replacement	\$2,000	\$0	\$0	\$2,000
Spare Pumps (All Pocket Pump Stations)									
Grinder Pump No. 1	15				Unit Replacement	\$2,000	\$0	\$0	\$0
Grinder Pump No. 2	15				Unit Replacement	\$2,000	\$0	\$0	\$0
Grinder Pump No. 3	15				Unit Replacement	\$2,000	\$0	\$0	\$0
Grinder Pump No. 4	15				Unit Replacement	\$2,000	\$0	\$0	\$0

<b>Table 7.16 Short-Lived Asset Reserve Schedule</b>									
Facility/Components	Overall Life Span	Service Age			Type of Service Required	Equipment Cost	Service Age		
		5	10	15			5	10	15
		Total	Total	Total			Total	Total	Total
Grinder Pump No. 5	15				Unit Replacement	\$2,000	\$0	\$0	\$0
<b>West Paso Pump Station</b>									
Pump No. 1	15		X		Unit Replacement	\$37,000	\$0	\$37,000	\$0
Pump No. 2	15			X	Unit Replacement	\$37,000	\$0	\$0	\$37,000
Pump No. 3	15			X	Unit Replacement	\$37,000	\$0	\$0	\$37,000
<b>East Paso Pump Station</b>									
Pump No. 1	15		X		Unit Replacement	\$7,100	\$0	\$7,100	\$0
Pump No. 2	15			X	Unit Replacement	\$7,100	\$0	\$0	\$7,100
<b>Baywood Pump Station</b>									
Pump No. 1	15		X		Unit Replacement	\$4,300	\$0	\$4,300	\$0
Pump No. 2	15			X	Unit Replacement	\$4,300	\$0	\$0	\$4,300
<b>Santa Ysabel Pump Station</b>									
Pump No. 1	15		X		Unit Replacement	\$7,100	\$0	\$7,100	\$0
Pump No. 2	15			X	Unit Replacement	\$7,100	\$0	\$0	\$7,100
<b>Lupine Pump Station</b>									
Pump No. 1	15		X		Unit Replacement	\$19,000	\$0	\$19,000	\$0
Pump No. 2	15			X	Unit Replacement	\$19,000	\$0	\$0	\$19,000
Pump No. 3	15			X	Unit Replacement	\$19,000	\$0	\$0	\$19,000
<b>Solano Pump Station</b>									
Pump No. 1	15		X		Unit Replacement	\$19,000	\$0	\$19,000	\$0
Pump No. 2	15			X	Unit Replacement	\$19,000	\$0	\$0	\$19,000
<b>Mountain Viewm Pump Station</b>									
Pump No. 1	15		X		Unit Replacement	\$4,300	\$0	\$4,300	\$0

<b>Table 7.16 Short-Lived Asset Reserve Schedule</b>										
Facility/Components		Overall Life Span	Service Age			Type of Service Required	Equipment Cost	Service Age		
			5	10	15			5	10	15
							Total	Total	Total	
	Pump No. 2	15			X	Unit Replacement	\$4,300	\$0	\$0	\$4,300
<b>Sunny Oaks Pump Station</b>										
	Pump No. 1	15		X		Unit Replacement	\$4,300	\$0	\$4,300	\$0
	Pump No. 2	15			X	Unit Replacement	\$4,300	\$0	\$0	\$4,300
<b>Mid Town Pump Station</b>										
	Pump No. 1	15		X		Unit Replacement	\$50,000	\$0	\$50,000	\$0
	Pump No. 2	15		X		Unit Replacement	\$50,000	\$0	\$50,000	\$0
	Pump No. 3	15			X	Unit Replacement	\$50,000	\$0	\$0	\$50,000
	Pump No. 4	15			X	Unit Replacement	\$50,000	\$0	\$0	\$50,000
	Pump No. 5	15			X	Unit Replacement	\$50,000	\$0	\$0	\$50,000
	Mag Meter	15			X	Unit Replacement	\$6,000	\$0	\$0	\$6,000
<b>Headworks</b>										
Influent Pump Station										
	Influent Pump No. 1	15		X		Unit Replacement	\$19,000	\$0	\$19,000	\$0
	Influent Pump No. 2	15		X		Unit Replacement	\$19,000	\$0	\$19,000	\$0
	Influent Pump No. 3	15			X	Unit Replacement	\$19,000	\$0	\$0	\$19,000
	Influent Pump No. 4	15			X	Unit Replacement	\$19,000	\$0	\$0	\$19,000
Influent Screening										
	Mechanical Bar Screen	10		X		Unit Replacement	\$138,000	\$0	\$138,000	\$0
	Screenings Washer/Compactor	10		X		Unit Replacement	\$62,000	\$0	\$62,000	\$0
Odor Control										

<b>Table 7.16 Short-Lived Asset Reserve Schedule</b>									
Facility/Components	Overall Life Span	Service Age			Type of Service Required	Equipment Cost	Service Age		
		5	10	15			5	10	15
		Total	Total	Total			Total	Total	Total
Headworks Supply Fan	15			X	Motor Replacement/ Major Mechanical Refurbishment	\$9,000	\$0	\$0	\$3,600
Headworks Exhaust Fan	15			X	Unit Replacement	\$9,000	\$0	\$0	\$9,000
Septage Receiving									
Septage Receiving Tank	30								
Septage Transfer Pump	15			X	Unit Replacement	\$16,000	\$0	\$0	\$16,000
<b>Oxidation Ditch No. 1</b>									
Anoxic Mixer No. 1	20								
Anoxic Mixer No. 2	20								
Aerator No. 1	20		X		Minor Mechanical Refurbishment	\$121,000	\$0	\$18,150	\$0
Aerator No. 2	20			X	Minor Mechanical Refurbishment	\$121,000	\$0	\$0	\$18,150
<b>Oxidation Ditch No. 2</b>									
Anoxic Mixer No. 1	20								
Anoxic Mixer No. 2	20								
Aerator No. 1	20		X		Minor Mechanical Refurbishment	\$121,000	\$0	\$18,150	\$0
Aerator No. 2	20			X	Minor Mechanical Refurbishment	\$121,000	\$0	\$0	\$18,150
<b>Secondary Clarifier No. 1</b>									
Clarifier Mechanism	20								
Scum Pump	15		X		Unit Replacement	\$8,000	\$0	\$8,000	\$0
<b>Secondary Clarifier No. 2</b>									

<b>Table 7.16 Short-Lived Asset Reserve Schedule</b>									
Facility/Components	Overall Life Span	Service Age			Type of Service Required	Equipment Cost	Service Age		
		5	10	15			5	10	15
		Total	Total	Total			Total	Total	Total
Clarifier Mechanism	20								
Scum Pump	15			X	Unit Replacement	\$8,000	\$0	\$0	\$8,000
<b>RAS/WAS Pump Station</b>									
RAS/WAS Pump No. 1	15		X		Motor Replacement/ Major Mechanical Refurbishment	\$30,000	\$0	\$12,000	\$0
RAS/WAS Pump No. 2	15			X	Unit Replacement	\$30,000	\$0	\$0	\$30,000
RAS/WAS Pump No. 3	15			X	Unit Replacement	\$30,000	\$0	\$0	\$30,000
RAS Mag Meter	15			X	Unit Replacement	\$6,000	\$0	\$0	\$6,000
WAS Mag Meter	15			X	Unit Replacement	\$4,000	\$0	\$0	\$4,000
<b>Solid Handling Facilities</b>									
Sludge Holding Tank	30								
Sludge Feed Pumps No. 1 (Progressive Cavity)	25		X		Motor Replacement/ Major Mechanical Refurbishment	\$40,000	\$0	\$16,000	\$0
Sludge Feed Pumps No.2 (Progressive Cavity)	25			X	Motor Replacement/ Major Mechanical Refurbishment	\$40,000	\$0	\$0	\$16,000
Belt Filter Press, Centrifuge or Screw Press	20						\$0	\$0	\$0
Polymer Feed Unit	15			X	Unit Replacement	\$31,000	\$0	\$0	\$31,000
Solids Conveyor No. 1	20								
Solids Conveyor No. 2	20								

<b>Table 7.16 Short-Lived Asset Reserve Schedule</b>									
Facility/Components	Overall Life Span	Service Age			Type of Service Required	Equipment Cost	Service Age		
		5	10	15			5	10	15
		Total	Total	Total			Total	Total	Total
Odor Control									
Solids Building Supply Fan	15			X	Motor Replacement/ Major Mechanical Refurbishment	\$9,000	\$0	\$0	\$3,600
Solids Building Exhaust Fan	15			X	Unit Replacement	\$9,000	\$0	\$0	\$9,000
<b>Tertiary Filtration</b>									
Disk Filter Unit No. 1	5	X			Unit Replacement	\$8,000	\$8,000	\$0	\$0
Disk Filter Unit No. 2	5	X			Unit Replacement	\$8,000	\$8,000	\$0	\$0
<b>Disinfection</b>									
NaOCl Storage Tank	30								
NaOCl Feed Pump No. 1	10		X		Unit Replacement	\$12,000	\$0	\$12,000	\$0
NaOCl Feed Pump No. 2	10		X		Unit Replacement	\$12,000	\$0	\$12,000	\$0
UV Bank No. 1	5	X			Unit Replacement	\$163,320	\$163,320	\$0	\$0
UV Bank No. 2	5	X			Unit Replacement	\$163,320	\$163,320	\$0	\$0
UV Bank No. 3	5	X			Unit Replacement	\$163,320	\$163,320	\$0	\$0
<b>Effluent Pump Station</b>									
Effluent Pump No. 1	25		X		Motor Replacement/ Major Mechanical Refurbishment	\$80,000	\$0	\$32,000	\$0
Effluent Pump No. 2	25			X	Motor Replacement/ Major Mechanical Refurbishment	\$80,000	\$0	\$0	\$32,000
Effluent Pump No. 3	25			X	Motor Replacement/ Major Mechanical Refurbishment	\$80,000	\$0	\$0	\$32,000

<b>Table 7.16 Short-Lived Asset Reserve Schedule</b>									
Facility/Components	Overall Life Span	Service Age			Type of Service Required	Equipment Cost	Service Age		
		5	10	15			5	10	15
		Total	Total	Total			Total	Total	Total
Plant Water Pump No. 1	25		X		Motor Replacement/Major Mechanical Refurbishment	\$21,000	\$0	\$8,400	\$0
Plant Water Pump No. 2	25			X	Motor Replacement/Major Mechanical Refurbishment	\$21,000	\$0	\$0	\$8,400
<b>Potable/Fire Water Storage</b>									
Water Storage Tank	30								
Fire Pump (Engine Driven)	20								
<b>Storm Water Pump Station</b>									
Storm Water Pump No. 1	20								
Storm Water Pump No. 2	20			X	Unit Replacement	\$15,000	\$0	\$0	\$15,000
<b>Totals</b>									
Total Cost per Replacement Period							<b>\$506,000</b>	<b>\$603,000</b>	<b>\$672,000</b>
Annual Cost per Replacement Period							\$101,200	\$60,300	\$44,800
<b>Total Annual Short-Lived Assets Reserve Fund Allocation</b>							<b>\$206,300</b>		

**CHAPTER 8: CONCLUSIONS AND RECOMMENDATIONS**

**8.1. RECOMMENDATIONS FOR ADDRESSING AFFORDABILITY CHALLENGES**

Project affordability has been a major challenge for the project since planning efforts began in 1983, following the Regional Water Quality Control Board’s mandate to cease septic tank discharges in the Prohibition Zone. The lack of existing wastewater infrastructure requires that the community construct all of the necessary facilities for collection, treatment, and effluent reuse or disposal at one time. The large capital expenditure, plus ongoing operational costs and individual on-lot connection costs result in a total project cost that far exceeds any affordability standard in the moderate income community of Los Osos.

Financing

The County has evaluated project affordability as part of its overall project planning and feasibility review. Without financial assistance, the total project costs, including homeowner financed on-lot costs, are projected to exceed \$250 per month for a typical, single family residence, which is more than 6% of the median household income (MHI) on an annual basis. The costs will be especially challenging for Los Osos where 33% of households receive Social Security income (50% higher than the statewide average), an indicator of fixed-income retirees.

Figure 8.1. Los Osos Affordability Thresholds by 2000 Census Household Age Category

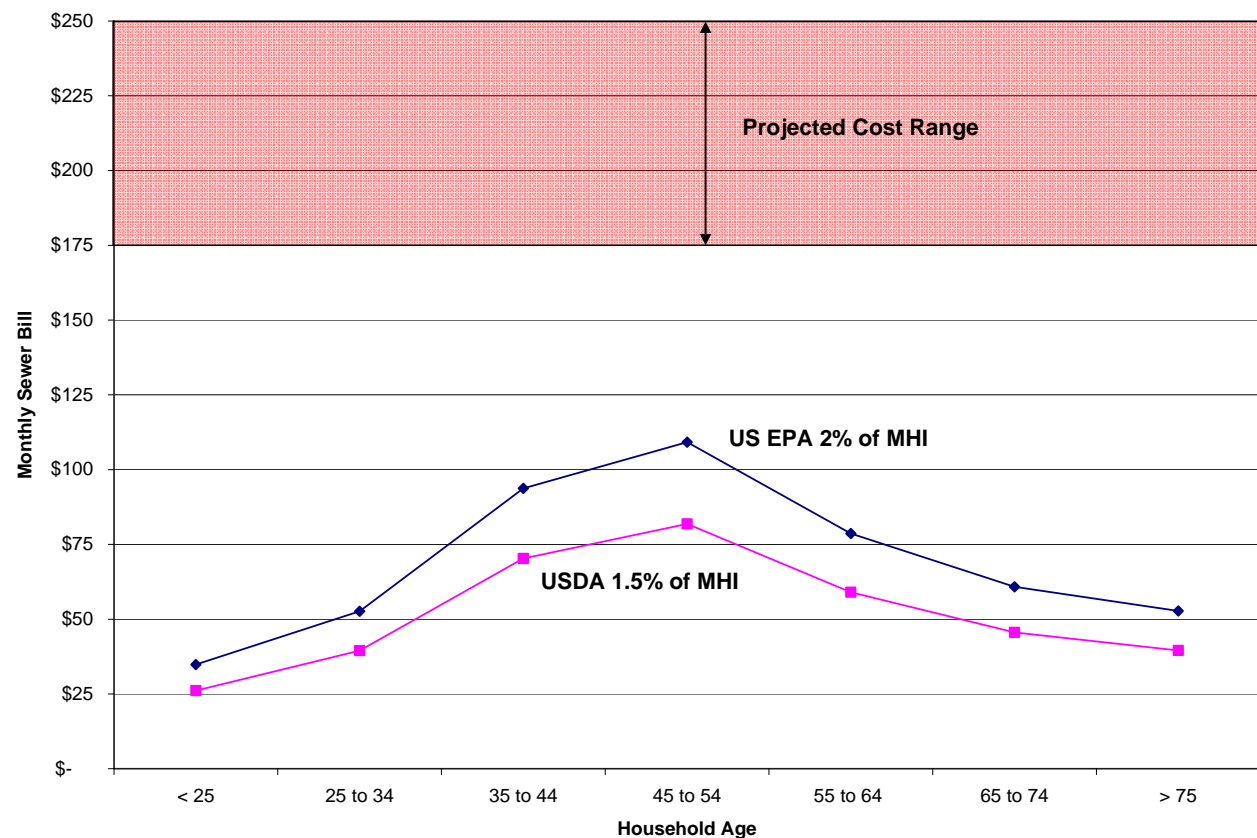



The overall affordability impact of the project can be greatly reduced with favorable financing from the USDA Rural Development Program. USDA financing of \$80 million, that includes a 20% grant component, will reduce the estimated costs for a typical single family residence by approximately \$43 per month. A project that is fully funded by the USDA, including a 20% grant component, would reduce costs by an estimated \$77 per month. This is more than a 30% savings over the estimated project costs without financial assistance and a substantial benefit to the community.

Figure 8.2 Benefits of Favorable USDA Financing

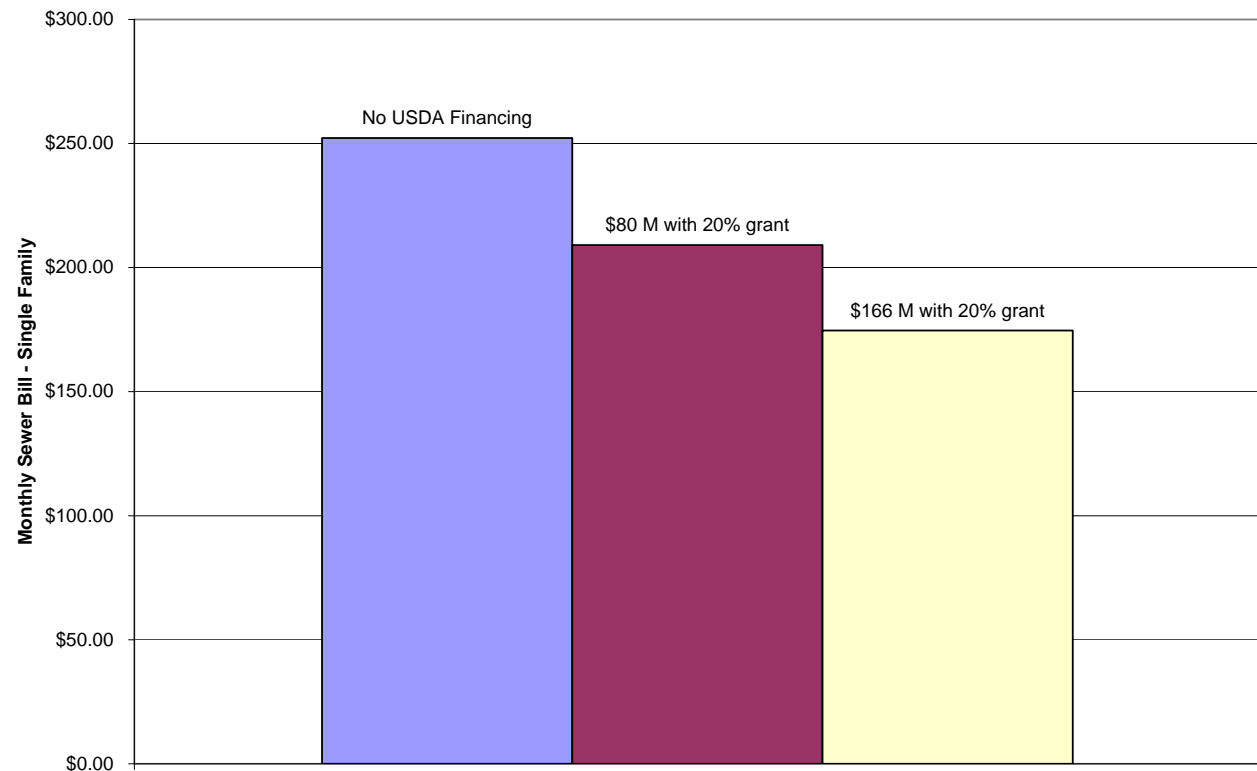

Mitigating project affordability impacts with USDA financing is only a first step in addressing the challenge. The County is also seeking financial assistance from several other sources, including extended term loans from the State Revolving Fund program, federal grants from the Water Resources Development Act, and state grants from the Proposition 50 and 84 Integrated Regional Water Management funds. Finally, the County is seeking to implement a financial assistance program for disadvantaged individuals in the community who are unable to afford the project costs.

Collection System Contracting

Construction contracting is the major capital cost of the project and it may be possible to realize significant savings over the current estimates. The current economic downturn has severely affected the California construction industry resulting in a highly competitive bidding climate.

Recent industry surveys, and the County's own experience, show that construction bids are being received at 30% - 40% below the engineer's estimates.

In order to capitalize on the favorable bidding climate, the County intends to pursue bids on the collection system as soon as possible after final regulatory permits are issued. The collection system represents 70% of the total construction costs and has the ability to realize the greatest savings. Early construction of the collection system is possible because the system is approximately 95% designed from the previous LOCSO project and can be made ready to advertise quickly by utilizing the existing design. The collection system also has a longer construction schedule than the treatment facility and should be started first in order to coordinate completion dates.

## REFERENCES

(Note: Hyperlinks to documents on Project Website provided for all references.)

1. Carollo Engineers, in association with Crawford, Multari & Clark Associates and Cleath and Associates. 2007a. San Luis Obispo County, Los Osos Wastewater Project Development, [Potential Viable Project Alternatives: Rough Screening Analysis Report](#), March.
2. Carollo Engineers, in association with Crawford, Multari & Clark Associates and Cleath and Associates. 2007b. San Luis Obispo County, Los Osos Wastewater Project Development, [Viable Project Alternatives: Fine Screening Analysis](#), Final. August.
3. Carollo Engineers. 2008a. San Luis Obispo County, Los Osos Wastewater Project Development, Technical Memorandum, [Effluent Reuse and Disposal Alternatives](#), Final. July.
4. Carollo Engineers. 2008b. San Luis Obispo County, Los Osos Wastewater Project Development, Technical Memorandum, [Decentralized Treatment](#), Final. November.
5. Carollo Engineers. 2008c. San Luis Obispo County, Los Osos Wastewater Project Development, Technical Memorandum, [Flows and Loads](#), Final. November.
6. Carollo Engineers. 2008d. San Luis Obispo County, Los Osos Wastewater Project Development, Technical Memorandum, [Septage Receiving Station Option](#), Final. August.
7. Carollo Engineers. 2008e. San Luis Obispo County, Los Osos Wastewater Project Development, Technical Memorandum, [Imported Water](#), Final. July.
8. Carollo Engineers. 2008f. San Luis Obispo County, Los Osos Wastewater Project Development, Technical Memorandum, [Low Pressure Collection System](#), Revised Final. July.
9. Carollo Engineers. 2008g. San Luis Obispo County, Los Osos Wastewater Project Development, Technical Memorandum, [Onsite Treatment](#), Final. May.
10. Carollo Engineers. 2008h. San Luis Obispo County, Los Osos Wastewater Project Development, Technical Memorandum, [Out of Town Conveyance](#), Final. July.
11. Carollo Engineers. 2008i. San Luis Obispo County, Los Osos Wastewater Project Development, Technical Memorandum, [Partially Mixed Facultative Pond Options](#), Final. July.

12. Carollo Engineers. 2008j. San Luis Obispo County, Los Osos Wastewater Project Development, Technical Memorandum, Projects Alternatives: [AB 32 - Greenhouse Gas Emissions Inventory](#), Final Draft. June.
13. Carollo Engineers. 2008k. San Luis Obispo County, Los Osos Wastewater Project Development, Technical Memorandum, [Septage Receiving Station Option](#), Final. August.
14. Carollo Engineers. 2008l. San Luis Obispo County, Los Osos Wastewater Project Development, Technical Memorandum, [Solids Handling Options](#), Final. August.
15. Los Osos Wastewater Project Technical Advisory Committee. 2007. [Pro/Con Analysis on Project Component Alternatives](#). August.
16. Michael Brandman Associates. 2008. [Draft Environmental Impact Report](#). County of San Luis Obispo Los Osos Wastewater Project State Clearinghouse No. 2007121034. November.
17. Michael Brandman Associates. 2009. [Final Environmental Impact Report/Response to Comments](#). County of San Luis Obispo Los Osos Wastewater Project State Clearinghouse No. 2007121034. March.
18. Montgomery Watson Harza. 2004a. Los Osos Community Services District. [Volume IV – Drawings for the Construction of Los Osos Wastewater Project Area B and Area C](#). February.
19. Montgomery Watson Harza. 2004b. Los Osos Community Services District. [Volume V – Drawings for the Construction of Los Osos Wastewater Project Area A and Area D](#). February.
20. Opinion Studies. 2009. [Los Osos Wastewater Project Community Advisory Survey](#). Final Report. March.
21. San Luis Obispo County Board of Supervisors. 2009. Los Osos Wastewater Project [Development Plan/Coastal Development Permit DRC2008-00103](#). Adopted Findings. September.
22. Wallace Group. 2007. [Engineer's Report for the San Luis Obispo County Wastewater Assessment District No. 1](#). December.

**LIST OF APPENDICES**

Appendix A: Los Osos Community Services District Collection System Bid Results 2/24/2005.

Appendix B: [Viable Project Alternatives: Fine Screening Analysis](#), Carollo Engineers, in association with Crawford, Multari & Clark Associates and Cleath and Associates; August 2007. (Under Separate Cover)

Appendix C: [Engineer's Report for the San Luis Obispo County Wastewater Assessment District No. 1](#), Wallace Group; December 2007. (Under Separate Cover)

W:\USDA Application\Prelim Engineering Report\Final PER May 2010.doc

**Appendix A:**  
**Los Osos Community Service District**  
**Collection System Bid Results: Received 2/24/2005**

Appendix 1 - Bid Schedule 1 ( Area B and C )

MWH				Eng. Est.		Low Bid #1		Low Bid #2	
Area B&C - Bid Schedule 1				MWH		Whitaker		Barnard	
Bid Item	Description	UOM	Quantity	Unit Price	Amount	Unit Price	Amount	Unit Price	Amount
1	Area Mobe/GCs/TCs	LS	1		\$940,224		\$1,200,000		\$1,590,000
2	Area Sheeting, Shoring, Sloping & Bracing	LS	1		\$703,034		\$492,000		\$4,839,000
3	48" Standard Gravity Sewer Manhole	EA	350	\$4,099	\$1,434,642	\$3,450	\$1,207,500	\$6,000	\$2,100,000
4	48" Drop Manhole	EA	20	\$4,728	\$94,553	\$5,810	\$116,200	\$13,000	\$260,000
5	48" Beaver Slide Manhole	EA	1	\$5,289	\$5,289	\$5,163	\$5,163	\$5,000	\$5,000
6	48" Force Main to Gravity Sewer Trans MH	EA	2	\$5,886	\$11,773	\$7,310	\$14,620	\$10,000	\$20,000
7	(Not Used)	EA	0		\$0		\$0		\$0
8	8" Gravity Sewer	LF	74000	\$64	\$4,700,504	\$132	\$9,768,000	\$120	\$8,880,000
9	10" Gravity Sewer	LF	2000	\$74	\$148,711	\$169	\$338,000	\$125	\$250,000
10	12" Gravity Sewer	LF	1600	\$64	\$102,052	\$108	\$172,800	\$150	\$240,000
11	(Not Used)	LF	0		\$0		\$0		\$0
12	15" Gravity Sewer	LF	3800	\$69	\$263,628	\$108	\$410,400	\$130	\$494,000
13	18" Gravity Sewer	LF	220	\$87	\$19,094	\$253	\$55,660	\$135	\$29,700
14	4" Sewer Lateral	EA	1700	\$2,715	\$4,615,942	\$1,220	\$2,074,000	\$1,800	\$3,060,000
15	4" Sewer Lateral from (E) Sewer MH	EA	5	\$3,175	\$15,875	\$1,490	\$7,450	\$4,000	\$20,000
16	6" Sewer Lateral	EA	24	\$2,842	\$68,214	\$1,577	\$37,848	\$1,500	\$36,000
17	(Not Used)	EA	0		\$0		\$0		\$0
18	48" Combination Air/Vacuum Release	EA	2	\$7,668	\$15,335	\$10,625	\$21,250	\$10,000	\$20,000
19	(Not Used)	LF	0		\$0		\$0		\$0
20	4" Force Main	LF	2900	\$32	\$92,001	\$89	\$258,100	\$30	\$87,000
21	(Not Used)	LF	0		\$0		\$0		\$0
22	(Not Used)	LF	0		\$0		\$0		\$0
23	10" Force Main	LF	7700	\$79	\$610,699	\$59	\$454,300	\$45	\$346,500
24	14" Force Main	LF	2800	\$95	\$266,451	\$119	\$333,200	\$75	\$210,000
25	3/4", 1/2" & 2" Polybutylene Water Svc	EA	320	\$1,413	\$452,067	\$1,038	\$332,160	\$2,150	\$688,000
26	(Not Used)	LF	0		\$0		\$0		\$0
27	(Not Used)	EA	0		\$0		\$0		\$0
28	2" Fiber Optic Cable Conduit	LF	3200	\$8	\$24,994	\$17	\$54,400	\$13	\$41,600
29	Fiber Optic Manhole	EA	6	\$4,708	\$28,247	\$5,142	\$30,852	\$5,500	\$33,000
30	Duplex Pump Station	EA	2	\$137,492	\$274,985	\$212,925	\$425,850	\$400,000	\$800,000
31	Triplex Pump Station	EA	1	\$250,708	\$250,708	\$316,750	\$316,750	\$600,000	\$600,000
32	(Not Used)	EA	0		\$0		\$0		\$0
33	Standby Power Facility	EA	3	\$228,471	\$685,412	\$252,350	\$757,050	\$350,000	\$1,050,000
34	6" Harvest Main	LF	6100	\$41	\$252,397	\$43	\$262,300	\$25	\$152,500
35	Harvest Main Valve Vaults	EA	2	\$5,885	\$11,770	\$15,445	\$30,890	\$20,000	\$40,000
36	Harvest Well/Well House	EA	2	\$170,008	\$340,016	\$289,149	\$578,298	\$700,000	\$1,400,000
37	(Not Used)	EA	0		\$0		\$0		\$0
38	Flow Control Vaults	EA	4	\$5,080	\$20,320	\$40,900	\$163,600	\$50,000	\$200,000
39	(Not Used)	EA	0		\$0		\$0		\$0
40	Reclaimed Water Turnouts	EA	11	\$2,540	\$27,940	\$1,803	\$19,833	\$4,450	\$48,950
41	6" Disposal Main	LF	1800	\$41	\$74,478	\$78	\$140,400	\$20	\$36,000
42	8" Disposal Main	LF	5400	\$55	\$297,912	\$60	\$324,000	\$24	\$129,600
43	12" Disposal Main	LF	8800	\$83	\$728,228	\$68	\$598,400	\$75	\$660,000
44	4" Disposal Header	LF	1200	\$28	\$33,101	\$17	\$20,400	\$11	\$13,200
45	6" Disposal Header	LF	720	\$41	\$29,791	\$20	\$14,400	\$12	\$8,640
46	8" Disposal Header	LF	17000	\$51	\$861,873	\$20	\$340,000	\$14	\$238,000
47	Broderson 4" Percolation Piping	LF	20000	\$25	\$507,492	\$75	\$1,500,000	\$60	\$1,200,000
48	Monitoring Wells	EA	10	\$4,675	\$46,749	\$4,150	\$41,500	\$4,800	\$48,000
49	24" Bored & Jacked Casing	LF	100	\$175	\$17,526	\$552	\$55,200	\$2,000	\$200,000
50	Fencing	LF	3200	\$19	\$60,960	\$18	\$57,600	\$25	\$80,000
51	Tree Removal at Broderson	EA	40	\$413	\$16,510	\$4,321	\$172,840	\$1,500	\$60,000
52	Install Native Vegetation	SF	350,000	\$0.13	\$44,450	\$1.70	\$595,000	\$2.25	\$787,500
53	LOVR Improvements	LS	1	\$254,000	\$254,000	\$276,500	\$276,500	\$500,000	\$500,000
54	Cultural Resources Caused Mobe/Demobe	EA	5	\$4,445	\$22,225	\$3,000	\$15,000	\$15,000	\$75,000
55	Overexcavation & Repl w/ Found Rock	CY	200	\$44	\$8,890	\$212	\$42,400	\$160	\$32,000
56	Add Pymt Restoration Ordered By ENGR	SF	12000	\$3.81	\$45,720	\$4.80	\$57,600	\$5.00	\$60,000
57	Utility Crossing Not Shown or Identified	EA	20	\$2,193	\$43,866	\$2,500	\$50,000	\$5,000	\$100,000
57A	Disinfect Construction Dewatering Water	DAY	60	\$3,810	\$228,600	\$4,455	\$267,300	\$3,200	\$192,000
					<b>\$19,800,000</b>			<b>\$24,507,014</b>	<b>\$31,961,190</b>

**Appendix A:**  
**Los Osos Community Service District**  
**Collection System Bid Results: Received 2/24/2005**

Los Osos Wastewater Project Area A&D - Bid Schedule 2				Eng. Est.		Low Bid #1	
Bid Item	Description	UOM	Quantity	MWH		Barnard	
				Unit Price	Amount	Unit Price	Amount
1	Area Mobe/GCs/TCs	LS	1		\$1,272,771		\$2,050,000
2	Area Sheetting, Shoring, Sloping & Bracing	LS	1		\$769,608		\$4,015,000
3	48" Standard Gravity Sewer Manhole	EA	340	\$4,092	\$1,391,110	\$6,600	\$2,244,000
4	48" Drop Manhole	EA	50	\$4,719	\$235,945	\$8,500	\$425,000
5	48" Beaver Slide Manhole	EA	28	\$5,279	\$147,820	\$5,000	\$140,000
6	48" Force Main to Gravity Sewer Trans MH	EA	4	\$5,876	\$23,502	\$10,000	\$40,000
7	48" Pocket PS FM Discharge MH	EA	12	\$5,876	\$70,506	\$6,500	\$78,000
8	8" Gravity Sewer	LF	93000	\$67	\$6,235,608	\$120	\$11,160,000
9	10" Gravity Sewer	LF	11000	\$69	\$762,644	\$125	\$1,375,000
10	12" Gravity Sewer	LF	3200	\$80	\$256,370	\$150	\$480,000
11	(Not Used)				\$0		\$0
12	15" Gravity Sewer	LF	2400	\$78	\$187,469	\$175	\$420,000
13	18" Gravity Sewer	LF	7000	\$85	\$595,290	\$140	\$980,000
14	4" Sewer Lateral	EA	3000	\$2,710	\$8,130,665	\$1,800	\$5,400,000
15	(Not Used)	EA	0		\$0		\$0
16	6" Sewer Lateral	EA	24	\$2,837	\$68,087	\$1,200	\$28,800
17	8" Sewer Lateral	EA	21	\$2,964	\$62,238	\$1,300	\$27,300
18	48" Combination Air/Vacuum Release	EA	31	\$7,654	\$237,259	\$9,500	\$294,500
19	2" Force Main	LF	8900	\$19	\$168,106	\$30	\$267,000
20	(Not Used)	LF	0		\$0		\$0
21	6" Force Main	LF	1800	\$47	\$85,499	\$110	\$198,000
22	8" Force Main	LF	2600	\$63	\$164,665	\$40	\$104,000
23	(Not Used)	LF	0		\$0		\$0
24	14" Force Main	LF	6000	\$95	\$569,952	\$80	\$480,000
25	3/4", 1/2" & 2" Polybutylene Water Svc	EA	480	\$1,410	\$676,854	\$2,150	\$1,032,000
26	Elec Duct Bank	LF	3100	\$44	\$135,258	\$320	\$992,000
27	Electrical or Instrumentation Pullbox	EA	7	\$587	\$4,109	\$7,000	\$49,000
28	2" Fiber Optic Cable Conduit	LF	8800	\$8	\$68,608	\$20	\$176,000
29	Fiber Optic Manhole	EA	15	\$4,699	\$70,491	\$10,000	\$150,000
30	Duplex Pump Station	EA	4	\$158,979	\$635,916	\$400,000	\$1,600,000
31	Triplex Pump Station	EA	1	\$171,084	\$171,084	\$500,000	\$500,000
32	Pocket Pump Station	EA	12	\$68,685	\$824,216	\$180,000	\$2,160,000
33	Standby Power Facility	EA	4	\$226,229	\$904,916	\$325,000	\$1,300,000
33A	Furnish Area B & Area C Equipment	LS	1	\$316,891	\$316,891	\$350,000	\$350,000
34	6" Harvest Main	LF	8500	\$41	\$351,026	\$30	\$255,000
35	Harvest Main Valve Vaults	EA	2	\$5,874	\$11,748	\$20,000	\$40,000
36	Harvest Well/Well House	EA	1	\$170,008	\$170,008	\$500,000	\$500,000
36A	East Paso Production Well	LS	1	\$215,486	\$215,486	\$500,000	\$500,000
37	(Not Used)	EA	0		\$0		\$0
38	Flow Control Vaults	EA	2	\$5,070	\$10,140	\$50,000	\$100,000
39	Vertical Disposal Wells	EA	48	\$5,070	\$243,372	\$15,000	\$720,000
40	Reclaimed Water Turnouts	EA	13	\$2,535	\$32,957	\$4,600	\$59,800
41	6" Disposal Main	LF	5000	\$41	\$206,486	\$40	\$200,000
42	8" Disposal Main	LF	4800	\$55	\$264,302	\$45	\$216,000
43	12" Disposal Main	LF	21700	\$83	\$1,792,397	\$60	\$1,302,000
44	4" Disposal Header	LF	200	\$28	\$5,506	\$30	\$6,000
45	(Not Used)	LF	0		\$0		\$0
46	(Not Used)	LF	0		\$0		\$0
47	(Not Used)	LF	0		\$0		\$0
48	Monitoring Wells	EA	10	\$4,666	\$46,659	\$5,000	\$50,000
49	30" Bored & Jacked Casing	LF	340	\$254	\$86,194	\$1,100	\$374,000
50	(Not Used)	LF	0		\$0		\$0
51	(Not Used)	EA	0		\$0		\$0
52	(Not Used)	SF	0		\$0		\$0
53	(Not Used)	LS	0		\$0		\$0
54	Cultural Resources Caused Mobe/Demobe	EA	15	\$4,437	\$66,551	\$15,000	\$225,000
55	Overexcavation & Repl w/ Found Rock	CY	300	\$44	\$13,310	\$160	\$48,000
56	Addl Pvmt Restoration Ordered By ENGR	SF	18000	\$3.80	\$68,454	\$5	\$90,000
57	Utility Crossing Not Shown or Identified	EA	20	\$2,189	\$43,786	\$5,000	\$100,000
57A	Disinfect Construction Dewatering Water	DAY	60	\$3,803	\$228,176	\$3,200	\$192,000
					\$29,100,000		\$43,493,400

*Nipomo Community  
Services District  
Strategic Plan  
2010 Update*



*April 14, 2010*



**Board of Directors**

Jim Harrison, President

Larry Vierheilig, Vice President

Ed Eby, Director

Mike Winn, Director

Bill Nelson, Director

**District Management Team**

Michael LeBrun, Interim General Manager

Peter Sevcik, District Engineer

Lisa Bognuda, Finance Director/Asst. General Manager

Tina Grietens, Utility Superintendent

**Strategic Plan Consultant – BHI Management Consulting**

Brent H. Ives, Principal Consultant



**Table of Contents**

Table of Contents	3
Introduction	4
Definitions	5
Strategic Plan Development	7
Mission, Core Values and Vision	9
Strategic Elements	11
1.0 Water	12
2.0 Wastewater	18
3.0 Partnerships/Regulatory Relations	22
4.0 Personnel/Organization	24
5.0 Administrative Management	27
6.0 Finances	29
7.0 Other Services	31
Table 1- The Strategic Plan "At-a-Glance"	35
Acronyms	37

## **Introduction**

A Strategic Plan is a top-level planning document for an organization to set clear direction over all operational aspects of its mission. It serves as a framework for decision making over a five-year period. It is a disciplined effort to produce fundamental decisions that shape what a District plans to accomplish by selecting a rational course of action. This planning process began with an environmental scan of the District's business environment including an objective assessment of the District's strengths, weaknesses, opportunities and threats. Input from various stakeholders was gathered and analyzed. Starting with that information the District's Mission, Vision, Core Values and the overall structure of this Strategic Plan were developed by the Board in workshop settings. Within the framework of that structure and the business environment, strategies and goals were developed to sustain and where appropriate improve the District over the next five years. At its highest level, this Strategic Plan seeks to strengthen and build upon opportunities while addressing areas of concern.

This plan also identifies actions, activities, and planning efforts that are currently underway and which are needed for continued success in operations and management of the District, and provides for periodic reviews and updates.

The strategic planning effort has focused on several or all of the following areas:

- Ensuring the District's long term financial health and stability;
- Cost efficiencies;
- Maintaining infrastructure;
- Stewardship of the environment;
- Sustaining a high performing, motivated and adaptable workforce;
- Fostering professional relationships when needed to better achieve our Mission; and
- Assuring clear, proactive and meaningful communications with the community we serve and the regulatory and land use agencies that impact District services.

## **Strategic Planning Definitions**

Mission Statement: A declaration of the District's purpose which succinctly describes why the District exists. All activities of the District will be in support of the Mission Statement. The Mission Statement is adopted by the Board of Directors. The Mission Statement will be reviewed annually but is intended to be constant over the long term.

Vision Statement: A statement that articulates where the District wants to be over the life of the Strategic Plan. It outlines at the highest level the key changes that must be achieved by the Strategic Plan. The Vision creates and drives strategy and tactics identified elsewhere in the Strategic Plan. The Vision Statement is adopted by the Board of Directors. The Vision Statement will be reviewed annually and will typically change more frequently than the Mission Statement to reflect the direction the Board wants to take the District over the five-year time horizon of the Strategic Plan.

Core Values: A guidepost to the things that the District values when faced with options and alternatives. These are used every time decisions are made as a District. The Core Values are adopted by the Board of Directors. The Core Values are reviewed annually but are intended to be relatively constant over the long term.

Strategic Elements: The broad and primary areas of District operations, planning, and management that are addressed and supported by the Strategic Plan goals. These essentially serve as the outline and organization of the Strategic Plan. The Strategic Elements are adopted by the Board of Directors. The Strategic Elements are reviewed annually but are intended, absent major new issues to be faced, to be relatively constant over the life of the five year Strategic Plan.

- Strategic Element Objective: A concise statement associated with each Strategic Element that describes the objective of that element. It explains why that element is important to the District's overall strategy.
- Strategic Element Strategy: A concise statement associated with each Strategic Element that describes how the Objective for that Element will be achieved.
- Measurement of Strategic Element: A concise statement associated with each Strategic Element that describes in simple high-level terms how an observer will know if the Objective for the Element is achieved.

Strategic Goals: Short statements of desired success. The goal statement is supported by a narrative that more fully explains the nature of the goal and the issues that the goal intends to address. The Strategic Goals are prepared by management and accepted by the Board. The Strategic Goals will change from year-to-year when the annual assessment is made of the progress on each Strategic Element. The Strategic goals straddle the line between policy (Board responsibility) and implementation (management responsibility) and as such are a collaborative effort of both the Board and management.

Strategic Work Plan: An objective-by-objective prioritized and year-by-year summary of the activities that management anticipates undertaking to achieve the Strategic Goals. The Work Plan is a tool and a road map to prioritize the broad approach to the Strategic Goals. The work plan is not a task or "to-do" list. It is presented at a higher level of milestones that are intended to be accomplished each year to move the District towards success on the broad Strategic Goals. The Strategic Work Plan is prepared by management. To the extent that it prioritizes the undertaking of efforts to implement the Strategic Elements policy direction from the Board is sought by management.

Business Plans: Detailed and shorter to mid-term implementation plans that will be prepared by each operating Division in the District at the time of budget preparation and separately from this over-arching Strategic Plan. The Business Plans identify specifically what each division intends to accomplish, what resources they require to do so and the detailed steps, milestones and metrics that will be used to assess their performance. Business Plans are prepared annually by mid-level management and are to be in alignment with the Strategic Work Plan.

### **Strategic Plan Development**

In FY2008-09, the District retained the services of BHI Management Consulting (BHI) to facilitate and coordinate the development of the District's five-year Strategic Plan. BHI first gathered input from the District employees in a number of meetings so as to allow direct and "ground level" input to Board during their deliberations on the Strategic Plan. To prepare for the Board workshop the Consultant circulated questionnaires to the District Board members on the matters they thought were most relevant to future strategy for the District. The following topics were discussed at all of the input gathering meetings:

- Mission
- Vision
- Core Values
- Current and future issues
- Important future projects

The Board supported this process as a way to allow all to participate in the foundation of the Strategic Plan. A full-day Board workshop was conducted. At the workshop the Board reviewed all input, revisited and refined the existing Mission Statement of the District, created a Vision Statement and developed Core Values for the District. The Board also identified the seven strategic elements providing balanced implementation actions across District operations that will support the Mission and achieve success of the Vision.

A steering committee, consisting of Senior Management and staff, worked with BHI to develop the Strategic Goals that support each Strategic Element. The Strategic Work Plan was developed in a collaborative fashion by Senior Management. District staff was regularly briefed in General Employee and in Division-level meetings about the process and content of the Strategic Plan as it was being developed. Using this process along with both external and internal input the Strategic Plan was assembled in a way that best articulates the Board's Vision and Strategy for the District over the next five years.

### **Continuation Process of the Plan**

A key part of the Strategic Planning process is to conduct an annual review and update of the Plan. This draft represents the first update and was accomplished in April of 2010. These reviews allow for regular maintenance of the Plan so that it reflects the actual progress and needs of the District. The reviews will be documented, and followed up with by either a Plan supplement or an updated Plan. A five-year planning horizon will be maintained with each review effort developing a new fifth year of actions, projects and initiatives.

The General Manager shall prepare a written quarterly update (Jan/Apr/July/Oct) on the progress of the Plan and report findings to the Board of Directors at a regular Board Meeting.

**DISTRICT MISSION**

*The Nipomo Community Services District's mission is to provide its customers with reliable, quality and cost-effective services now and in the future.*

**DISTRICT CORE VALUES**

- *Is it open, transparent and responsive to our customers?*
- *Is it sensitive to rates and cost efficient?*
- *Does it support our commitment to maintenance of our facilities and infrastructure?*
- *Does it support our ability to provide reliability in the services we provide?*
- *Does it support the welfare of our employees?*
- *Does it protect the rural character of our community?*



## **DISTRICT VISION**

### **The District:**

- **has sufficient water supplies to meet current needs and is actively planning for and funding future needs.**
- **has investments in our infrastructure to maintain reliable and efficient services.**
- **is practicing environmental stewardship to protect our resources**
- **has a growing understanding of available resources and conveys that information to customers.**
- **has substantially upgraded and continues to upgrade water and wastewater systems to accommodate new water supplies and meet growth and regulatory requirements.**
- **is sustaining a qualified, long-term and productive workforce to assure an effective organization.**
- **continues conservative, well managed finances reaching incremental targeted reserve goals.**
- **achieves a high level of public support through public outreach.**
- **is utilizing proven and cost-effective technologies to enhance the performance of our Mission.**
- **has improved relationships with local agencies, regulators and providers.**
- **has constructed and is operating at least one neighborhood park.**

## **Strategic Elements**

Strategic Elements represent the vital areas of the District's operation and management. They assure that the implementation of work to be performed in support of the Mission and Vision are comprehensive in nature and properly cover the District in all areas. Strategic elements are derived from the foundational Mission and Vision statements of the District. They are linked to action and results through the Strategic Goals written in each area and the Strategic Work Plan, Business Plans and Employee Goals. Within the five-year period covered by this Strategic Plan, these Elements assure that all aspects of District operations are well supported and are moving forward in a way that reflects Board priorities and creates balanced implementation. They are not ordered in any particular order but meant to be equally important to the long-term balanced future of the District.

The Strategic Work Plan which contains the supportive actions and initiatives organized and prioritized by year within the planning period, is presented along with each Strategic Goal and is also consolidated in tabular form in Table 1 - Strategic Plan "At-a-Glance" (pg. 20). These too are not prioritized within each section of the Plan but by how they are implemented throughout the five-year term of the Plan. Business Plans and Employee Goals are not a part of the Strategic Plan; these are developed on a one to two year timeframe with tasks, and are handled within the management structure of the District.

The Strategic Elements are:

- 1.0 Water
- 2.0 Wastewater
- 3.0 Partnerships/Regulatory Relations
- 4.0 Personnel/Organization
- 5.0 Administrative Management
- 6.0 Finances
- 7.0 Other Services

## 1.0 Water

**Objective: The objective is to ensure that water supplies of high quality and quantity are available for existing and future customers.**

**Strategy: We will do this by aggressively managing water resources under the District's control, developing a diversified water supply portfolio, and by partnering with and/or influencing agencies that have an impact on the quantity and quality of the water supplies available to the District.**

### 1.1 Protect, Enhance, and Assess Available Water Supplies

Continuous assessment of available groundwater in storage, quality trends of groundwater, threats to water supplies, and the ability to serve existing and future customers is necessary to maintain adequate service levels. District production wells will be monitored and analyzed to insure operational reliability and water quality. Production parameters and quality will be tracked. District wells will also be monitored in support of District and NMMA Technical Group efforts to understand basin production and health. The District will increase understanding of stormwater and return flow inputs to the local basin in order to inform efforts to maximize quantity and quality of these supply elements. Customers and users of the basin will be informed as to the 'semi-closed loop' nature of the basin and the need to protect the basin at home. The District is in the process of converting monthly well level depth measurement to continuous readings and monthly evaluation of District well level depths. Similarly, the practice of semi-annual (Spring and Fall) basin-wide storage calculation based on the County's reading of water well levels, will be augmented to include continuous monitoring of the coastal sentinel wells and the "key" inland wells and the periodic water quality measurements set forth in the 2008 NMMA Annual Report.

In addition to this high-priority, continuous reporting conversion, the District will support and advance NMMA Technical Group efforts to monitor and evaluate area groundwater resources. The NMMA Technical Group has identified six longer term management recommendations including the development of a third Coastal Monitoring Well at Oso Flaco. Implementation of these additional management recommendations will improve the understanding of the groundwater basin and provide information critical to management of the basin. The District will participate in the identification and implementation of Technical Group Annual Report recommendations.

Over the past three years, the District has reported the volume of groundwater in storage as an indicator of basin health; however, this measurement metric has been criticized for not accurately representing the basin's geo-hydrology. With the publication of the 2008 NMMA Annual Report, there is now a new metric available that is supported by the technical experts serving on the Technical Group (TG). The District will coordinate with the NMMA TG to periodically assess the basin status and to implement appropriate response plans when the TG or the Court determines that the basin is in a Severe or Potentially-Severe Water Shortage situation.

The District's Urban Water Management Plan (UWMP) provides the basis for the District's Water Supply Program and it must be kept current so the District can understand current water resource demands and plan to meet future needs. The State requires updates of the UWMP every five years to be eligible to receive state grant funding. The District will track existing customer demand, commitments to future development, and plans for future development as it actively revises the UWMP in 2010.

## **1.2 Secure New Supplies to Meet Demands**

WATERLINE INTERTIE PROJECT - As detailed in the 2009 NMMA Annual Report, the average annual consumptive use of water exceeds the average annual recharge. This situation is not healthy and must be corrected to prevent future saltwater

intrusion. The District is proceeding with implementation of the “Business Plan” for development of the Waterline Intertie Project (WIP) including environmental review, design, permits, funding, property acquisition, construction, start up, testing and operations. Once the project is operational, the District will reduce its groundwater pumping and provide new water for development infill within District boundaries, but no new water will be available for annexations. Once the project is completed, at least one new operator position will be required to manage the new facilities and treatment processes. [ESTIMATED COMPLETION DATE = FY11-12].

FUTURE WATER SUPPLY AUGMENTATION Additional water, beyond the WIP, will be necessary to support development of the lands within the District’s Sphere of Influence. The District will need to develop at least one additional supplemental water project. The District Board has ordered staff to implement a work program for development of a desalination project. This work program will be re-written as a business plan, the initial phase of research will be conducted, potential partnerships will be negotiated and an initial project proposal will be developed within the five-year term of this Strategic Plan [ESTIMATED COMPLETION DATE = FY14-15].

### **1.3 Upgrade and Maintain Water Storage and Distribution Works**

WATER AND SEWER MASTER PLAN - The District is proceeding with the phased implementation of its Water and Sewer Master Plan. Every year as the budget is adopted, technical staff recommends and the Board selects projects to upgrade the storage and distribution works. In FY09-10 NCSD has funded the first phase of the Willow Road extension. In FY10-11 the District will consider funding the second phase of the Willow Road Extension. In addition, projects to replace and rehabilitate existing water storage and distribution works are funded each year including tank rehabilitation, hydrant replacement, valve replacement and well refurbishment [ESTIMATED COMPLETION DATE = FY14-15].

PREVENTIVE MAINTENANCE - Historically, the District has not developed a written preventive maintenance plan and consequently has spent considerable funds to repair problems as they occur on an expensive case-by-case basis rather than efficiently planning for upgrades. The Board has approved an overall Management and Operations Plan that calls for the development of a formalized preventive maintenance program. The District will purchase the program software and fully implement the program by the end of FY10-11 for both water and sewer facilities [ESTIMATED COMPLETION DATE = FY10-11].

SCADA (REMOTE ELECTRONIC MONITORING OF WATER AND SEWER FACILITIES) – The District currently uses a proprietary Supervisory Control and Data Acquisition System (SCADA) that has limited capabilities to monitor, control, and document water and sewer facility performance. These limitations reduce the District’s ability to control and manage its water and sewer systems. The District will upgrade its SCADA system to improve the efficiency of operation and to enhance both the evaluation and control of facilities [ESTIMATED COMPLETION DATE = FY10-11].

GIS - The District currently uses a Geographic Information System (GIS) system that is not accessible to field personnel and is very cumbersome to update. These limitations reduce the ability of staff to get information on water and sewer facilities and to keep information current. The District will upgrade and regularly update this system so that it can be accessed by all field personnel and other relevant agencies and integrated into the Operations and Management Plan [ESTIMATED COMPLETION DATE = FY10-11] .

WATER QUALITY ANALYSIS - The District currently contracts out all laboratory analysis of water quality with both a primary contractor and a control contractor to ensure accuracy. Although the vendors have performed well, reliance on vendors limits the District’s ability to timely evaluate the performance of NCSD’s water and

sewer facilities and to respond to emergencies. Over the next three years, the District will set up an in-house water quality laboratory to provide for internal control and for emergency response [ESTIMATED COMPLETION DATE = FY12-13].

#### **1.4 Consistently Reduce Average Demand per Customer**

The District has adopted a comprehensive Water Conservation Program, which includes twelve major conservation efforts. The goal of the Plan is to reduce average demand per customer so that less new water is required. As detailed in the 2005 Urban Water Management Plan, water saved through conservation is much cheaper per unit than water developed through new water supply projects. Staff has been implementing the Water Conservation Program with a fulltime position and budgeted funding. The District is implementing software to track the effectiveness of each effort and to evaluate the actual reduction in demand per customer. The District reduced production per connection by 16% over the last 5 years and will continue efforts to reduce average annual use per connection over the long-term. The largest factors that affect the demand per customer are outdoor irrigation and water rates. Implementation of the District's 2008 Water Conservation Plan will be prioritized to focus on reduction of irrigation use. The District's successful Water Conservation Workshops will be expanded with more workshops offered in 2010-11. The Board has agreed to evaluate 2010-2013 Water Rates in 2010 to determine if alternative water-rate structures can reduce water usage. The Board has also agreed to evaluate 2012-2015 sewer rates in 2011.

#### **1.5 Comply with State and Federal regulations and mandates**

The District must comply with both State and Federal Water Regulations and submit the required water quality reports as well as prepare the annual Consumer Confidence Report. An additional major component of this compliance is tracking changes to the District water system and new regulations, and implementing regulations as they become applicable and/or effective. This tracking includes an evaluation of each new regulation to determine the cost to implement, documenting

the changes necessary in facilities and operations, commenting to the regulatory body regarding impacts to the District and then implementing the final regulation after it is adopted. [On-going]



## 2.0 Wastewater

**Objective: Collect, treat and beneficially dispose of wastewater and its by-products to meet the needs of existing and future customers.**

**Strategy: We will do this by the careful management of effluent and biosolids, using prudent planning and maintenance, with financial strategies to maintain sufficient capacity and respond to changing regulatory demands.**

### 2.1 Efficiently operate collection, treatment and disposal works

PREVENTIVE MAINTENANCE - Historically, the District has not developed a written preventive maintenance plan and consequently has spent considerable funds to repair problems as they occur on an expensive case-by-case basis rather than efficiently planning for upgrades. The Board has approved an overall Management and Operations Plan that calls for the development of a formalized preventive maintenance program. The District expects to purchase the program software and fully implement the program by the end of FY10-11 for both water and sewer facilities [ESTIMATED COMPLETION DATE = FY10-11].

SCADA (REMOTE ELECTRONIC MONITORING OF WATER AND SEWER FACILITIES) –The District currently uses a proprietary Supervisory Control And Data Acquisition (SCADA) system that has limited capabilities to monitor, control, and document water and sewer facility performance. These limitations reduce the District's ability to control and manage its water and sewer systems creating costs inefficiencies. The District will upgrade its SCADA system to improve the efficiency of operation and to enhance both the evaluation and control of facilities [ESTIMATED COMPLETION DATE = FY10-11].

GIS - The District currently uses a Geographic Information System (GIS) system that is not accessible to field personnel and is very cumbersome to update. These limitations reduce the ability of staff to get information on water and sewer facilities

and to keep information current increasing trip miles and increasing “time to project completion”. The District will upgrade and regularly update this system so that it can be accessed by all field personnel and other relevant agencies and integrated into the Operations and Management Plan [ESTIMATED COMPLETION DATE = FY10-11] .

WASTEWATER QUALITY ANALYSIS - The District currently contracts out all laboratory analysis of wastewater quality with both a primary contractor and a control contractor to ensure accuracy. Although the vendors have performed well, reliance on vendors limits the District’s ability to operate the new Biolac® Treatment System, to timely evaluate the performance of NCS D’s water and sewer facilities and to respond to emergencies. The District will continue to expand an in-house water quality laboratory to provide for internal control & for emergency response [ESTIMATED COMPLETION DATE = FY12-13].

**2.2 Upgrade and maintain collection and treatment works**

SOUTHLAND WASTEWATER TREATMENT FACILITY - The District is proceeding with implementation of the “Business Plan” for development of the Southland WWTF Upgrade Project (SoWWTF) including environmental review, design, permits, funding, construction, start up, testing and operations. The project will result in improved effluent quality, improved bio-solids management, and increased capacity. The Project is planned in three phases. The first Phase is being aggressively pursued. Subsequent Phases will be timed on plant flow and community growth rates. Once this project is completed, two new operator positions will be required to manage the new operation. [ESTIMATED COMPLETION DATE = FY12-13].

WATER AND SEWER MASTER PLANS - The District is proceeding with the phased implementation of its Water and Sewer Master Plan. Every year as the budget is adopted, the Board endorses projects to upgrade the collection, treatment and disposal works. In FY11-12 the District expects to fund the replacement of the South Frontage Collector. In addition, projects to replace and rehabilitate existing collection

and treatment works are funded each year including lift station rehabilitation, manhole rehabilitation and Closed Circuit Television (CCTV) pipe condition assessment [ESTIMATED COMPLETION DATE = ON-GOING] .

EFFLUENT WATER QUALITY IMPROVEMENT - Separate from the SoWWTF upgrade, the District will pursue improvement of effluent water quality through the following source control efforts:

- The District will develop a Salts Management Program for both the Town Sewer Service Area and for the Blacklake Sewer Service Area. The program will include both a regulatory component prohibiting the installation of new self-regenerative water softeners and an education and rebate component to encourage existing customers who have self-regenerative water softeners to either abandon the use of water softeners or to convert to canister style systems.
- The District will continue implementation of a Fats Oils and Grease reduction program and expand the program to include development of information to residential customers.
- The District will develop education and outreach information about other customer source threats to effluent water quality (medical wastes, grease, oils, fats) and septic tank management. The effort will be integrated with supply water quality education efforts (1.1). [ESTIMATED COMPLETION DATE = FY11-12 and Ongoing].

### **2.3 Select disposal solution for Southland Effluent and implement**

The District currently discharges the treated wastewater from the Southland WWTF into the adjacent percolation ponds; however, this wastewater hits an earthquake fault that runs along Orchard Road and a subsurface mound has resulted. This mound will grow closer to the surface and ultimately create health problems unless additional disposal solutions can be implemented. The Board has directed staff to implement a work program to evaluate the feasibility of alternative disposal sites and

to compare the most promising disposal sites in the SoWWTF EIR. The District will then propose a subsequent project and develop a business plan for implementation of the selected disposal option [ESTIMATED COMPLETION DATE = FY12-13].

**2.4 Select disposal solutions for Southland Bio-Solids and implement**

In addition to creating treated wastewater, both treatment facilities also produce bio-solids. Historically, the District has stockpiled its bio-solids; however, the available storage space has been exhausted and it is now necessary to either recycle/reuse these bio-solids or dispose of them. The District will develop a Bio-solids Management Program for both the Town Sewer Service Area and for the Blacklake Sewer Service Area. The program will include the investigation of long-term cost-effective bio-solids reuse options and implementation of a strategy [ESTIMATED COMPLETION DATE = FY12-13].

**2.5 Comply with State and Federal regulations and mandates**

The District must comply with both State and Federal Water Regulations and submit the required water quality reports as well as continue the electronic reporting of sewer system overflows and complete development of a Sewer System Management Plan. Another major component of this compliance is tracking changes to the District treatment and collection system and new regulations and implementing regulations as they become effective and/or applicable. This tracking includes an evaluation of each new regulation to determine the cost to implement, documenting the changes necessary in facilities and operations, commenting to the regulatory body regarding impacts to NCSD and then implementing the final regulation after it is adopted.

### 3.0 Partnerships/Regulatory Relations

**Objective: To foster beneficial relationships to accomplish the goals of the District.**

**Strategy: We will do this by embracing strategic ties with other organizations, working closely with regulators, developing a deliberate legislative agenda and participating in professional associations.**

#### 3.1 Strengthen strategic ties with neighboring purveyors and Technical Group

The District shares the Nipomo Mesa Management Area with two other major purveyors (Golden State Water Company, and the Rural Water Company), the Woodlands Mutual Water Company, Mesa Dunes Water Company, 13 other smaller private water companies, and thousands of private land/well owners including golf course and agricultural users. The District is also a participant in the Nipomo Mesa Management Area Technical Group along with ConocoPhillips, the Woodlands, Golden State Water Company and the agricultural landowners. To achieve viable management of the groundwater basin and to develop equitable funding for the importation of supplemental water, the District will negotiate agreements with the individual purveyors and fully participate in the Technical Group process. In addition, NCSD will monitor the growth in production and number of NMMA mutual water companies and to seek mechanisms to integrate mutual water company activities into the management of the basin.

#### 3.2 Strengthen strategic ties with County of SLO, APCD, County Environmental Health and WRAC

All land use decision-making for the Nipomo Mesa Water Conservation Area (NMWCA) is vested in the County of San Luis Obispo. The County needs feedback from the District on the availability of water and sewer capacity in regards to the development of policies and the consideration of private development projects. The District will closely monitor both policies and projects under consideration and communicate on each such policy and project so that the County understands the

relevant constraints. Where policies conflict, the District will take the additional action necessary to prevent overuse of the resources.

### **3.3 Work closely with RWQCB, SWRCB, and State DPH**

As stated above in Goals 1.5 and 2.5, the District is subject to new regulations and once those regulations are promulgated, the District must implement. Prior to adoption, the District will provide feedback to the Regional Board, the State Board, and the Public Health Officer. Pending regulations include the septic management systems (SWRCB and RWQCB), Basin Plan Amendments (RWQCB and State DPH), and recharge regulations (State DPH).

### **3.4 Develop a deliberate legislative Agenda**

The District is subject to the dictates of new state and federal legislation and the requirements of initiatives. The District can also secure funding through the legislative process. The District will monitor proposed bills and initiatives and comment on those bills and initiatives and provide information to the community where appropriate. The District also will lobby for state and federal funding for its major infrastructure projects with the help of professional lobbyists and provision of information to our respective state and federal representatives.

### **3.5 Participate in LAFCO, IWMA, CSDA, CSDA Chapter, AWWA, CRWA, CWEA**

The District is subject to LAFCO's decisions regarding the District's Sphere of Influence, latent powers and annexation and will track any review of municipal services being conducted by LAFCO. Likewise, the District will participate fully in the Integrated Waste Management Authority regarding solid waste regulations and funding. The District will also take advantage of the information and resources available through CSDA, the SLO County Chapter of CSDA, AWWA, CRWA, and CWEA.

## 4.0 Personnel/Organization

**Objective: To employ and retain a high quality, motivated workforce.**

**Strategy: We will do this by utilizing sound policies and personnel practices, offering competitive compensation and benefits, providing opportunities for training, development and professional growth, while ensuring a safe and secure workplace.**

### 4.1 Retain long-term employees & attract new employees by providing industry-competitive salary/benefits

Although the District has a good track record in terms of keeping long-term employees, it is becoming very difficult to recruit new employees especially where certifications are required. To continue to retain existing employees and to be competitive in regards to new recruitments, the District will need to offer competitive salaries and benefits. The concern of the Board of Directors is that employees will be recognized for the level and scope of work described in their job description and that they are paid on a fair and competitive basis that allows the District to recruit and retain a high-quality staff. NCSO will update the Total Compensation Study every five years. The District most recently conducted this study in 2006).

### 4.2 Provide appropriate training and education for all employees

A formal program for training staff to improve work knowledge and performance is in development. Staff is enrolled in training as a part of an overall strategy. A formal staff development program will include using in-house training programs, webinars and other available resources and integrate training goals into the performance management system.

### 4.3 Continue commitment to a safe workplace environment

Each week the District management team meets, discusses and addresses, any safety issues, accidents or injuries. The District's Utility Superintendent conducts bi-weekly safety tailgate meetings and the District's Engineer and Safety Officer

conducts safety tailgate meetings with the Utility crew on a monthly basis. In addition, the entire Staff participates in a quarterly safety meeting. At these meetings, various safety topics are addressed. Staff is encouraged to participate and suggestions are encouraged. The District's Safety Officer presents written policies, collectively the 'Safety Policy' on safety-related topics to the Board of Directors for approval. The Safety Officer updates the Safety Policy on an annual basis and as required by changes in operations or regulations. A formal review of the Policy by the Board of Directors is conducted every 5-years or when policy level changes to the Program are required. The Safety Policy (call to attention) is included in the Employee Safety Manual. These programs will continue with an emphasis on finding ways to improve workplace safety.

**4.4 Develop and maintain efficient disaster response capability**

The District is committed to continuing hands-on training and education and purchasing the necessary equipment for District personnel to respond to an emergency. District staff received the initial emergency response training during FY08-09 and FY 09-10. The District has established an Emergency Operations Center, updated the Emergency Response Plan, conducted additional emergency response training and will regularly test the District's plan with tabletop exercises. The District has joined and participates in CALWARN, the statewide water sector mutual aid agreement and will integrate CALWARN protocols including resource typing into the District's Emergency Response Plan.

**4.5 Integrate technology into operations to maximize productivity & communications**

BILLING AND ACCOUNTING SYSTEM - The District's current utility billing and accounting system was implemented in 2000. It is a DOS-based system and sometimes does not provide Staff with flexibility in data retrieval, manipulation and reporting. The District will investigate other utility billing and accounting software and determine if newer technology would be beneficial to staff and its customers. Staff will



report their findings to the Board of Directors [ESTIMATED COMPLETION DATE = FY 11-12].

GIS/SCADA - Additionally, the field crew currently has limited access to either the GIS database or the SCADA system when they are in the field. The District will purchase and implement a computer-based maintenance management system [ESTIMATED COMPLETION DATE = FY10-11].

## 5.0 Administrative Management

***Objective: To create, maintain and implement policies and procedures to ensure sound management of the District.***

***Strategy: We will conduct periodic review, refine and implement policies and procedures, and assure that the General Manager has the direction and tools necessary for successful operations throughout the District.***

### 5.1 Maintain clear and functional policies and procedures

The District is committed to providing clear and functional policies and procedures for its employees, Board of Directors and customers. The District maintains a Safety Manual and Policy Manual and each employee and Board Member have a copy. These documents are available to the public. District staff monitors these policies and procedures and is committed to keeping them current and up-to-date. The District will train staff on implementation of all new policies and provide refresher information on established policy.

### 5.2 Complete conversion to electronically archived District records

As with most organizations the volume of historic records has increased to levels that defy manual inspection of paper copies. The District is currently in the process of completing the conversion of its customer utility billing accounts data to electronic format for storage and retrieval so that this information can be organized and accessed. In addition, District Staff has scanned and electronically-stored Ordinances, Resolutions, Board Minutes and recorded documents. The District will prepare a plan to scan and electronically store all District documents, including project files and provide for redundant back-ups.

**5.3 Provide for excellent Customer Service**

The District is committed to provide excellent customer service. Staff prides itself on being friendly, knowledgeable and helpful. Staff is committed to continuing to have a “real person” answer the phone during business hours.

In the coming years District staff will continue to track and analyze electronic and web based payment methods to facilitate customer service and administrative efficiency.

A review of industry standards and trends in this area will be undertaken by staff in 2010-2011 and a report will be made to the Board of Directors.

## 6.0 Finances

***Objective:*** Recognizing that finances are critical to the ability of the District to effectively carry out the Mission the District must ensure the short-term and long-term fiscal health of the District.

***Strategy:*** The District will forecast and plan income and expenditures and provide financial resources to fund current and planned obligations.

### 6.1 Operate all enterprise funds to be financially sound.

The District is committed to operating all enterprise funds to be balanced and financially sound with reserves that cover both unforeseen emergencies and projected cash flow variations. In order to accomplish this, the rates and charges must reflect the cost of providing the services including the cost of replacing and/or rehabilitating aging facilities. Rates and charges will be reviewed at least every three years by a professional rate consultant.

### 6.2 Achieve and maintain targeted operating reserves

The targeted operating reserve for the Water Fund is 50% of the Operations and Maintenance Budget less Funded Replacement. The targeted operating reserve for the Sewer Funds is 25% of the Operations and Maintenance Budget less Funded Replacement. In the adopted budget for FY2009-10, the targeted operating reserves have been met. The targeted operating reserves will be included in the review of rates and charges at least every three years by a professional rate consultant.

### 6.3 Ensure that decisions consider short-term and long-term fiscal impacts

Every decision made may have a short-term and long-term fiscal impact on the District. Requests to expend funds that are not approved in the adopted annual budget will consider both the short-term and long-term fiscal impacts of the decision and be approved by the Board of Directors.

**6.4 Minimize commitment of discretionary resources to long-term projects**

The District has one major source of discretionary funds -- property tax revenues. Past, property tax revenues are not a guaranteed revenue stream. The State of California ERAF (Educational Revenue Augmentation Fund) has "raided" the District's property taxes every year since 1992, totaling more than \$3.7M. The District will minimize commitment of property taxes to long-term projects and instead use property tax reserves to pay for large one-time projects that benefit a cross section of the community. If property taxes are committed to a long-term project, the District will have a contingency plan in place to provide funding for that project if property taxes cease.

**6.5 Protect Reserves with Sound Investment Policy and Investments**

The District's Investment Policy and investment portfolio are structured to protect the available reserves instead of maximizing interest yield. The District will review its Investment Policy at least annually and adjust to changes in market conditions.

**6.6 Review Other Post-Employment Benefits (OPEB) for future employees**

The District currently provides one OPEB to its fully vested CalPERS employees. This OPEB is health insurance. The District joined California Employee Benefit Retirement Trust (CEBRT) in 2008 and began funding this obligation as required by GASB 45. This is a substantial financial obligation of the District and the Board of Directors would like to review the options of providing OPEB to future employees.

## 7.0 Other Services

**Objective:** To provide solid waste service and neighborhood parks throughout the District, and street lighting, drainage and street landscape maintenance in designated areas of the District.

**Strategy:**

- In the area of Solid Waste we will do this by continually looking for ways to improve the service through judicious contracting, recycling, diversion and assessing alternative methods while being sensitive to rates.
- In the area of Street Lighting we will do this by seeking ways to provide reliable street lighting in appropriate areas.
- In the area of Drainage we will do this by assuring that the drainage systems are efficient, protect the community from storm related flooding and meet State drainage requirements.
- In the area of Parks we will do this by constructing a community park and seek ways to provide increased parks and Open Space for the community.
- In the area of Street Landscaping we will do this by continually assessing the type and health of the existing landscaping within our landscape maintenance zone and making appropriate upgrades and performing needed and appropriate maintenance.

### 7A. Solid Waste

#### 7.A.1 Promote recycling to ensure reduction target compliance

State law requires SLO County to divert at least 50% of the historic base period refuse into recycling and/or green waste. The District will promote recycling and provide maximum education to the Community regarding recycling solutions. The District will practice recycling throughout the organization.

#### 7.A.2 Provide Additional Solid Waste Services

The Franchise Fee paid by the Solid Waste Vendor is available to pay for solid waste services that would otherwise go unmet. The District will promote the two semi-

annual clean up events, the annual Creek Clean Up and the Annual Chipping event and consider other initiatives that achieve solid waste goals.

**7.A.3 Communicate with Customers**

One component of promoting beneficial diversion of waste involves provision of information to customers regarding options to recycle and to minimize solid waste through its newsletter and its outreach program.

**7B. Street Lighting**

**7.B.1. Monitor Maintenance of Facilities and Respond to Observed Problems**

The District is responsible for maintenance of the streetlights in the Fairways Village at Blacklake. The District will respond to complaints and inspect these facilities to determine their need for maintenance. Where maintenance is warranted, the District will budget for the work needed and perform that work.

**7.B.2 Communicate with Customers**

The District relies on feedback from the customers within the Fairways to identify problems and will respond promptly where such reports are rendered.

**7C. Drainage**

**7.C.1. Monitor Maintenance of Facilities and Respond to Observed Problems**

The District is responsible for management of the Folkert Oaks Drainage Basin off of Juniper Road. The District responds to complaints and inspects the drainage basin on an annual basis to determine if maintenance is required. Where maintenance is required, the District will implement.

**7.C.2 Communicate with Customers**

The District relies on feedback from the customers within the Folkert Oaks Mobile Home Park to identify problems and respond promptly where such reports are rendered.

**7D. Parks**

**7.D.1 Develop Miller Park**

The Community Survey commissioned in 2007 shows a desire for additional park facilities in general and neighborhood parks in specific. The District has a Business Plan for development of Miller Park which includes negotiation of a MOU with SLO County, adoption of a financial plan, application to LAFCO to activate Parks Latent Authority, formation of a zone of benefit regarding assessing properties near the park to pay for a portion of operations cost, completing the environmental review, refining the design, conducting the assessment election, securing LAFCO approval, transferring the property, funding the initial core improvements, constructing the core improvements, funding the secondary improvements, constructing the secondary improvements and operating the park. In December 2009 an assessment vote to fund a portion of Miller Park annual operations costs failed. The District will continue with the project. Funding may be established and a final design by FY 12-13. Construction may commence by FY 13-14.

**7.D.2 Communicate with Constituents**

The District will communicate with all of its constituents regarding the progress in development of Miller Park and the consideration of other parks priorities.

**7.D.3 Plan for Other Parks & Open Space**

Once Miller Park is under construction, the District will survey other park or open space development options, develop a draft Parks Master Plan, secure community



feedback on the Draft Plan, agree on the priorities for development of additional facilities and then proceed with the development of the next high priority facility.

**7E. Street Landscaping**

**7.E.1 Monitor landscape maintenance and respond to problems**

The District is responsible for maintenance of some of the street landscaping in the Vista Verde subdivision and contracts with a landscape maintenance firm to perform the actual maintenance. The District will review the work of the then incumbent firm and provide guidance to that firm. Periodically, the District will use an open competition to select the contractor to do the maintenance.

**7.E.2 Communicate with Customers**

The District relies on feedback from the residents within Vista Verde to identify problems and respond promptly where such reports are rendered.

**Table 1 –The Strategic Plan “At a Glance”**

STRATEGIC ELEMENTS	STRATEGIC GOALS	Estimated Completion Date (FY)
<b>1.0 WATER</b>	1.1 Protect, Enhance and Assess available Water Supplies	On-going
	1.2 Secure New supplies	FY11-15
	1.3 Upgrade and maintain available storage and distribution works	FY10-15
	1.4 Consistently reduce average demand per customer	On-going
	1.5 Comply with State and Fed. regulations	On-going
<b>2.0 WASTEWATER</b>	2.1 Efficiently operate collection, treatment and disposal works	FY10-13
	2.2 Improve treatment works	FY12-13 On-going
	2.3 Select disposal solution for Southland	FY12-13
	2.4 Provide for Disposal of Biosolids	FY12-13
	2.5 Comply with State and Federal regulations and mandates	On-going
<b>3.0 PARTNERSHIP/ REGULATORY RELATIONS</b>	3.1 Strengthen ties with neighboring agencies and technical groups	On-going
	3.2 Strengthen ties with County of SLO, APCD, County Environmental Health and WRAC	On-going
	3.3 Work closely with RWQCB and State DPH	On-going
	3.4 Develop deliberate legislative agenda	On-going
	3.5 Participate in LAFCO, IWMA, CSDA, CSDA Chapter, AWWA and CWEF	On-going
<b>4.0 PERSONNEL/ ORGANIZATION</b>	4.1 Retain and attract new employees	On-going
	4.2 Provide appropriate training and education for employees	On-going
	4.3 Continue commitment to a safe workplace environment	On-going
	4.4 Develop and maintain efficient disaster response capability	On-going
	4.5 Integrate operational technology	FY11-12

<b>5.0 ADMINISTRATIVE MANAGEMENT</b>	5.1 Maintain clear and functional policies and procedures	On-going
	5.2 Complete conversion to electronic records	FY 11-12
	5.3 Provide excellent customer service	On-going
<b>6.0 FINANCES</b>	6.1 Operate all enterprise funds to be financially sound	On-going
	6.2 Achieve targeted operating and non-operating reserves	On-going
	6.3 Ensure that decisions consider short and long term fiscal impacts	On-going
	6.4 Minimize commitment of discretionary resource long-term projects	Ongoing
	6.5 Protect reserves with sound investment policy and investments	On-going
	6.6 Review Other Post-Employment Benefits (OPEB)	FY 11-12
<b>7.0 OTHER SERVICES</b>	7.A.1 Promote recycling	On-going
	7.A.2 Provide additional solid waste services	On-going
	7.A.3 Communicate with customers	On-going
	7.B.1 Monitor maintenance of facilities	On-going
	7.B.2 Communicate with customers	On-going
	7.C.1 Monitor maintenance of facilities	On-going
	7.C.2 Communicate with customers	On-going
	7.D.1 Develop Miller Park	FY13-14
	7.D.2 Communicate with constituents	On-going
	7.D.3 Plan for parks and open space	On-going
	7.E.1 Monitor landscape maintenance	On-going
	7.E.2 Communicate with residents	On-going

**Acronyms**

AWWA – American Water Works Association  
CCTV – Closed Circuit Television  
CERBT – California Employee Retirement Benefit Trust  
CRWA – California Rural Water Association  
CSDA – California Special Districts Association  
CWEA – California Water Education Association  
EIR – Environmental Impact Report  
GIS – Geographic Information System  
IWMA – Integrated Waste Management Authority  
LAFCO – Local Agency Formation Commission  
NMMA – Nipomo Mesa Management Area  
NMMA TG – NMMA Technical Group  
NMWCA – Nipomo Mesa Water Conservation Area  
OPEB – Other Post-Employment Benefits  
RWQCB – Regional Water Quality Control Board  
SCADA – Supervisory Control and Data Acquisition  
SoWWTF – Southland Wastewater Treatment Facility  
STATE DPH – State Department of Public Health  
SWRCB – State Water Resources Control Board  
UWMP – Urban Water Management Plan  
WIP – Waterline Intertie Project  
WRAC – Water Resources Advisory Committee

# Evaluation of Supplemental Water Alternatives— Technical Memorandum No. 1 Constraints Analysis

---

## **Nipomo Community Services District**

President	Michael Winn
Vice President	Larry Vierheilig
Director	Cliff Trotter
Director	Ed Eby
Director	Jim Harrison
General Manager	Bruce Buel

## **Boyle Engineering Corporation**

Project Manager	Mike Nunley, PE
Project Engineers	Malcolm McEwen, PE
	Cesar Romero, PE
	Rosalyn Piza, EIT

19996.32  
June 2007

**DRAFT**

**BOYLE**

1194 Pacific Street, Suite #204

San Luis Obispo, CA 93401

# Table of Contents

---

1.0 Introduction.....	1-1
2.0 Project Objective.....	2-1
3.0 Santa Maria Valley Groundwater .....	3-1
Introduction.....	3-1
Previous Studies and Documents.....	3-1
Santa Maria Groundwater Basin.....	3-3
Supply .....	3-3
Quality.....	3-4
Reliability.....	3-5
Required Facilities .....	3-6
Implementation Schedule.....	3-7
Constraints .....	3-7
4.0 CCWA, State, or “Other” Water.....	4-1
Introduction.....	4-1
Previous Studies and Documents.....	4-3
Acquisition Scenarios .....	4-4
Supply .....	4-7
Unused and Excess Capacity for Treatment and Conveyance.....	4-8
Quality.....	4-9
Reliability.....	4-10
Required Facilities .....	4-12
Implementation Schedule.....	4-13
Constraints .....	4-14
5.0 Desalination of Sea Water/Cooling Water.....	5-1
Introduction.....	5-1

Previous Studies.....	5-5
Supply .....	5-6
Quality.....	5-7
Reliability.....	5-8
Required Facilities .....	5-8
Implementation Schedule.....	5-9
Constraints .....	5-9
6.0 Brackish Agricultural Drainage from Oso Flaco Watershed.....	6-1
Introduction.....	6-1
Setting .....	6-1
Recent Studies.....	6-1
Supply .....	6-3
Quality and Restoration Efforts .....	6-3
Reliability.....	6-5
Required Facilities .....	6-5
Implementation Schedule.....	6-7
Constraints .....	6-7
7.0 Nacimiento Water Project Extension.....	7-1
Introduction.....	7-1
Previous Studies.....	7-1
Supply .....	7-3
Quality.....	7-3
Reliability.....	7-4
Required Facilities .....	7-4
Implementation Schedule.....	7-6
Constraints .....	7-7
8.0 Recharge of Groundwater with Recycled Water from Southland WWTF ....	8-1
Introduction.....	8-1



Previous Studies/Documents.....	8-1
Supply .....	8-2
Quality.....	8-4
Reliability.....	8-4
Required Facilities .....	8-5
Implementation Schedule.....	8-6
Constraints .....	8-6
9.0 Direct Use of Recycled Water in-lieu of Groundwater Pumping.....	9-1
Introduction.....	9-1
Previous Studies/Documents.....	9-3
Supply .....	9-3
Quality.....	9-6
Reliability.....	9-7
Required Facilities .....	9-7
Implementation Schedule.....	9-8
Constraints .....	9-8
10.0 Summary of Water Quality.....	10-1
11.0 Comparison of Alternatives .....	11-1
Supply .....	11-1
Water Quality.....	11-2
Reliability.....	11-3
Implementation Schedule.....	11-4
Institutional Constraints .....	11-5
Legal Constraints .....	11-6
Regulatory Constraints.....	11-7
Numerical Ranking of Alternatives .....	11-8
12.0 Conclusions.....	12-1
Comparison of Alternatives .....	12-1

Summary of Relative Costs.....	12-2
References.....	R-1
Reports/Documents.....	R-1
Water Quality Data .....	R-3
Personal Communication .....	R-5

Appendix A - Relative Cost Comparison

Appendix B – Hydrogeology Constraints Analyses

Appendix C – CCAMP Data for Oso Flaco Watershed

Appendix D – Environmental and Permitting Constraints Analysis

**List of Tables**

Table 4-1 - Capacities of the CCWA Treatment and Conveyance Facilities	4-9
Table 4-2 - Predicted SWP/CCWA Water Deliveries	4-11
Table 5-1 – Desalination Alternatives	5-1
Table 5-2 – Facilities Required for Desalination Alternatives—3,000 afy	5-8
Table 5-3 – Facilities Required for Desalination Alternatives—6,300 afy	5-8
Table 5-4 – Probable Costs per acre-foot for each Desalination Alternative	5-10
Table 6-1 – CCAMP Findings and Beneficial Uses in the Oso Flaco watershed	6-4
Table 6-2 – Probable Treatment requirements for Oso Flaco Water Source	6-6
Table 10-1 - Summary of Water Quality	10-2

**List of Figures**

Figure 3-1 - Santa Maria Groundwater Alternatives	3-2
Figure 4-1 - CCWA, State, or “Other” Water	4-6
Figure 4-2 - SWP Delivery Reliability	4-10
Figure 4-3 - CVP Delivery Reliability	4-11
Figure 5-1 – Partner with Nipomo Refinery Desalination Alternative	5-3
Figure 5-2 – Stand-alone Desalination Alternative	5-4
Figure 5-3 – Partner with SSLOCSD Desalination Alternative	5-5
Figure 6-1 – Oso Flaco Watershed	6-2
Figure 7-1 – Nacimiento Water Project Extension	7-2
Figure 8-1 – Groundwater Recharge of Recycled Water	8-3
Figure 9-1 – Groundwater Exchange of Recycled Water for Direct Reuse	9-2
Figure 9-2 – Net Effect of Direct Reuse Exchange on Groundwater	9-4

# 1.0 Introduction

The District is currently pursuing design and construction of transmission, storage, and pumping facilities to convey City of Santa Maria water to the District via the proposed Waterline Intertie Project. A 2005 Memorandum of Understanding between the two agencies defined conditions, on a preliminary basis, for transferring this water. The District's costs for that project will include purchase cost for the water from Santa Maria, cost for improvements within the Santa Maria system (if required), as well as capital and operations/maintenance costs for all required transmission, storage, and pumping facilities.

Boyle prepared a 2006 Preliminary Engineering Memorandum for the Nipomo Waterline Intertie Project that provided a preliminary analysis of hydraulic conditions within both the Nipomo and Santa Maria systems; disinfection alternatives; pipeline alignments; and storage/pumping options. Following this evaluation, the District moved to continue work after alternatives were explored. The Board directed staff to assess cost and feasibility for other supplemental water alternatives.

Two types of alternatives were evaluated: 1) those that import supplemental water from outside the NMMA; and 2) those that attempt to better manage the existing NMMA water resources.

Importation alternatives considered in this evaluation include the following:

- Santa Maria River Valley Groundwater – The City of Santa Maria may be willing to sell some of their entitlement to underflow water to the District. Facilities required to utilize this resource would include a wellfield, possibly treatment (based on regulatory review), pumping, storage, and a connection from the proposed wellfield to the District distribution system. It is assumed collector wells would be located along the River, near the end of Hutton Road, at the Bonita Well site, or possibly on other properties along the River.

The Santa Maria groundwater basin is in adjudication; any activities that modify the hydrologic balance previously presented in testimony that becomes an element of the final stipulation may require Court approval.

- State Water or Exchange through State Water Pipeline – Unused capacity in the State Water Project (SWP) pipeline from one or more Central Coast Water Authority (CCWA) member agencies/project participants or exchange water could be provided via a turnout along the State Water Pipeline within the District boundary. Water would either be delivered directly to the District water system, or indirectly via aquifer storage and recovery.
- Desalinated Seawater or Brackish Water – Facility could be constructed at Nipomo Refinery (using cooling water as a source), another location owned by the District, or at the South San Luis Obispo County Sanitation District (SSLOCS) Wastewater Treatment Facility.
- Brackish Agricultural Drainage – Either shallow ground water or surface runoff from agricultural lands into Oso Flaco Lake could be used as a water supply. In addition, a project to treat this water for District use could also be designed to improve the health of the Oso Flaco wetlands.

- Nacimiento Water Project – The District could participate in an extension of the Nacimiento Water Project from the City of San Luis Obispo to Nipomo, allowing the District to receive either raw or treated surface water.

Water resource management alternatives considered in this evaluation include the following:

- Groundwater Recharge with Recycled Wastewater Treated effluent from Southland Wastewater Treatment Facility (WWTF) could be applied to percolation ponds to better manage groundwater resources.
- Exchange Treated Wastewater for Direct Use Treated effluent from Southland WWTF could be used for irrigation of crops, parks, or golf courses, in order to reduce pumping by agricultural users near groundwater depressions.

# 2.0 Project Objective

This report represents Task 1 of the Evaluation of Supplemental Water Alternatives. The objective of the entire evaluation is to identify feasible alternative water supply options for the Nipomo Community Services District, and to recommend a strategy for implementing one or more of these alternative supplies. Tasks 2 and 3 will evaluate alternatives in greater detail.

Boyle reviewed existing sources of information to determine the permitting, legal, engineering, and hydrogeological constraints associated with utilizing each of the water source options listed above. This report includes a discussion of these issues (including identification of any “fatal flaws” associated with any particular option), a matrix to rank the feasibility of each alternative, and a recommended course of action.

The following constraints were addressed:

## **Physical**

- Hydrogeology
- Supply
- Water quality
- Reliability

## **Institutional and Legal Constraints**

- Required approvals from various stakeholders
- Water rights and the Santa Maria Groundwater adjudication litigation

## **Drinking Water and Wastewater Permitting**

- California Department of Health Services
- Regional Water Quality Control Board

## **Implementation**

- Required facilities
- Impacts to environmental resources and required resource agency permits
- Time required for implementation
- Conceptual cost comparison

For comparison to the cost opinions developed in the draft Waterline Intertie Project Technical Memorandum, the design flows for this study were 3,000 acre-feet per year (AFY) and 6,300 AFY.

# 3.0 Santa Maria Valley Groundwater

## Introduction

The City of Santa Maria has rights to three “supplies” of groundwater within the Santa Maria River Basin, which could be available for sale or transfer to NCSD:

- Native Yield from the Santa Maria Valley Management Area (SMVMA) of the Santa Maria Groundwater Basin;
- Additional Yield from the SMVMA due to the implementation of the Twitchell Reservoir; and
- Return flows from State Water Project.

This section considers the constraints associated with acquiring water supplies from the City of Santa Maria and pumping the groundwater from a new well site adjacent to the Santa Maria River. Three possible locations are shown on Figure 3-1.

## Previous Studies and Documents



The following list summarizes the studies and documents referenced for this evaluation:

- 2005 Urban Water Management Plan for City of Santa Maria, Public Review Draft (CH2MHill, February 2007)
- 2005 Santa Barbara County Groundwater Report (Santa Barbara County Public Works, Water Resources Department, March 2006)
- Water Resources of the Arroyo Grande - Nipomo Mesa Area (DWR Southern District, 2002)
- Stipulation of the Santa Maria Groundwater Litigation (June 30, 2005)
- Statement of Decision Regarding Trial Phase V of the Santa Maria Groundwater Litigation (Jan. 08, 2007)
- Nipomo Mesa Groundwater Resource Capacity Study (SS Papadopoulos, March 2004)



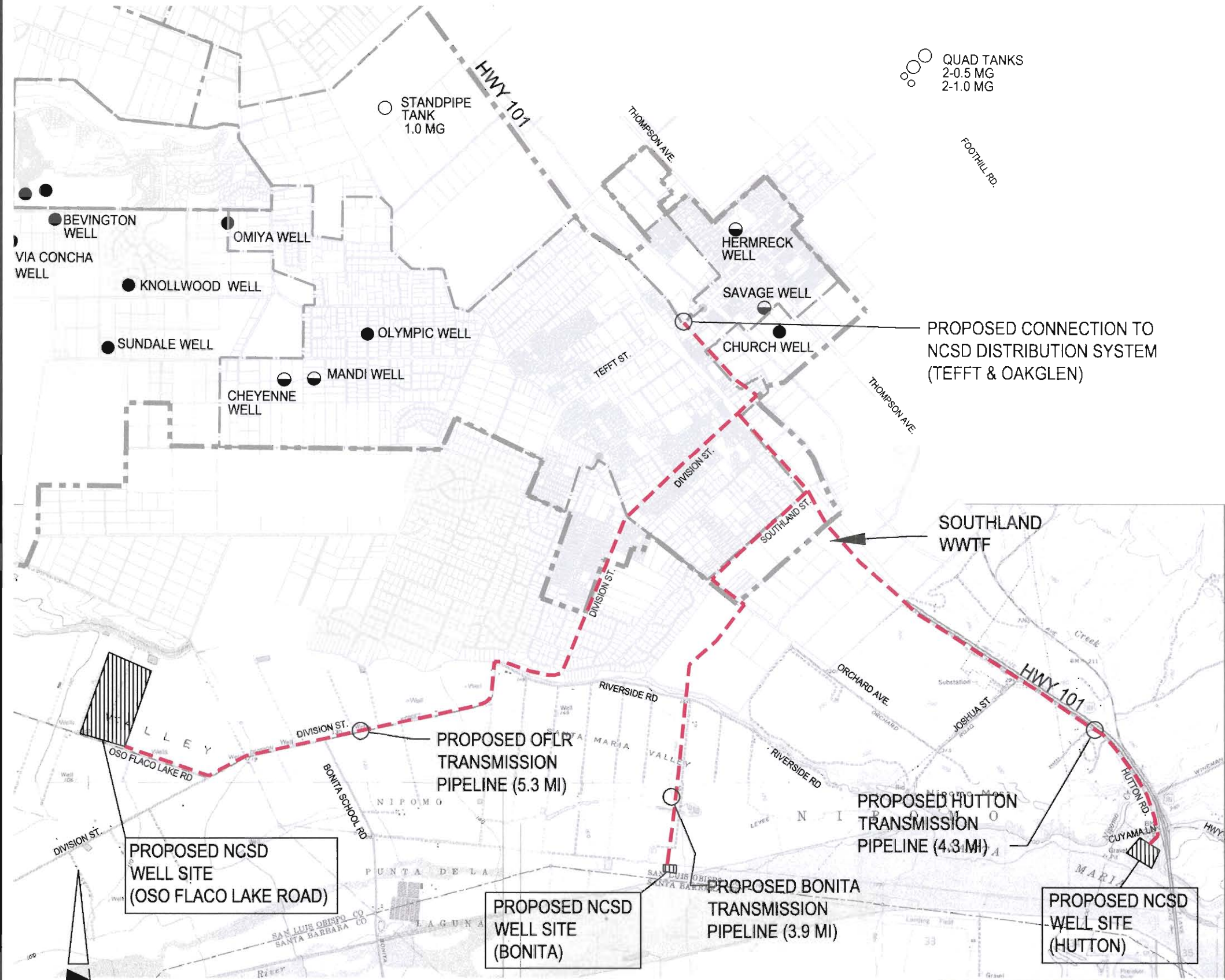



**NOTES:**

1. DISTANCES LISTED REPRESENT ROUTE FROM EACH WELL SITE TO PROPOSED CONNECTION LOCATION. MASTER PLANNED PROJECTS TO IMPROVE TRANSMISSION CAPACITY ACROSS HWY-101 WILL BE CONSTRUCTED AND MAY REDUCE AMOUNT OF PIPELINE REQUIRED FOR THE CONNECTION.



 QUAD TANKS  
 2-1.0 MG

**LEGEND**

-  NIPOMO CSD WELLS
-  NIPOMO CSD WELLS (STANDBY)
-  NIPOMO CSD TANKS
-  FUTURE WATER SYSTEM SERVICE AREA BOUNDARY
-  EXISTING WATER SYSTEM SERVICE AREA BOUNDARY
-  PROPOSED PIPELINE

DWG: W:\Nipomo CSD (19996)\19996.32 (Alternative Water Supply)\CAD\Design\Revised Figures and Plates\Figure 3-1\_SMV Groundwater.dwg  
 DATE: Jun 11, 2007 8:35am XREFS: BASE MAP Well Sites IMAGES: Map1.TIF Map2.TIF Map3.TIF Map4.TIF Map5.TIF  
 USER: cramer



NIPOMO CSD EVALUATION OF  
 SUPPLEMENTAL WATER ALTERNATIVES  
 SANTA MARIA VALLEY GROUNDWATER

BEC  
 PROJECT NO.  
 19996.32

FIGURE  
 3-1

## Santa Maria Groundwater Basin

The Santa Maria Groundwater Basin (Basin) is composed of three management areas as described in the Santa Maria Groundwater Litigation proceedings. The three management areas are: (1) Northern Cities Management Area; (2) Nipomo Mesa Management Area (NMMA); and (3) Santa Maria Valley Management Area (SMVMA). The proposed well sites are all located within the Santa Maria Valley Management Area.

It is uncertain whether implementation of this alternative will provide a “new” supply to the NCSD, or if it will merely intercept the existing inflow of groundwater from the SMVMA to the NMMA (SAIC, pers. comm., 2007). The hydrogeologic interaction between NMMA and the SMVMA is currently not well defined. According to the 2005 Santa Barbara County Groundwater Report, these separate management areas appear to have limited interaction. However, the 2002 DWR study notes that groundwater flow from the SMVMA to the NMMA may occur and is dependent on groundwater elevation and hydraulic gradients. That report further estimated inflow to the NMMA from the SMVMA to be between 1,200 and 5,100 AFY in 1995. Current information regarding groundwater elevations and/or hydraulic gradients across the study area is needed to help assess the net effect to the NMMA water budget of pumping groundwater from the proposed well sites.

Of perhaps greater concern is the very real likelihood that extracting groundwater at the locations proposed would lower groundwater elevations, thereby reducing the hydraulic gradient between the SMVMA and the NMMA (SAIC, 2007). If such a reduction in gradient were to occur, the effect would be to reduce the quantity of groundwater flowing from SMVMA to NMMA, and by extension, could also reduce the movement of groundwater from NMMA to the Northern Cities Management Area. These changes in flow between aquifers would likely be prohibited under the pending adjudication.

These considerations, that pumping groundwater from near the Santa Maria River will result in no net gain to the District, *and* that significant institutional and legal obstacles would oppose such pumping, could be considered “fatal flaws” for this alternative.

## Supply

Note that the Santa Maria Groundwater Adjudication has not come to final judgment. Therefore, the quantities of groundwater available to the City of Santa Maria summarized below should be considered preliminary estimates.

Local Groundwater Basin Water. The City of Santa Maria’s UWMP identifies the city’s current and projected groundwater supply at 12,795 AFY. This supply is based on appropriative rights to native yield from the Santa Maria Groundwater Basin as defined in the Stipulation. The Court’s Statement of



Decision Regarding Phase 5 of the Trial indicates the City has established prescriptive rights to 5,100 AFY of basin water. Based on personal communication with Mr. Jim Markman (Special Counsel to NCSD) the safe yield based on prescriptive rights is approximately 500-700 AFY within the study area.

Twitchell Water. Twitchell Reservoir releases are controlled to maximize recharge of the groundwater basin through percolation along the Santa Maria River bed. The Santa Maria Groundwater Stipulation identifies the Twitchell Yield to be 32,000 AFY of “Developed Water,” and allocates 14,300 AFY to the City of Santa Maria.

Return Flows from SWP. The June 30, 2005 Stipulation of the Santa Maria Groundwater Litigation defines “Return Flows” as “Groundwater derived from use and recharge within the Basin of water delivered through State Water Project facilities.”

The City of Santa Maria’s SWP Table A Amount is 16,200 AFY with an additional 1,620 AFY of drought buffer through its contract with CCWA. According to the Stipulation, the City of Santa Maria is entitled to recapture 65% of its SWP water used in the basin. The City’s 2005 Draft UWMP<sup>1</sup> projects that its purchase of SWP water will remain steady at 13,706 AFY until the year 2030. Consequently, its “Return Flows” are also projected to remain steady at 8,909 AFY.

Thus, the City of Santa Maria has rights to return flows and local basin water equaling 9,409 to 9,609 AFY. Including Twitchell water raises the amount to between 23,709 and 23,909 AFY. Considering that the City plans to increase groundwater use to only 6,858 AFY in the year 2030, it appears sufficient water is available to meet NCSD needs.

The NCSD could acquire rights for up to 3,000 AFY of SWP return flows and prescriptive rights from the City. A place-of-use modification to the Twitchell Reservoir operating license (discussed later) could be used to secure up to 6,300 AFY of Twitchell water.

## Quality

Only limited groundwater quality data is available within the study area along the Santa Maria River. Data from a Cuyama Lane Water Company well located just north of the proposed Hutton Well Site is summarized in Table 10-1. The single sample shows a specific conductance value of 530 umhos/cm, a value that would typically correspond with a TDS value of 340 ppm. (This is considered a relatively “soft” water.). It is also expected that nitrate will be an issue within the subject part of the Santa Maria Valley.

As indicated above, the City benefits from a portion of its discharged effluent in the form of SWP return flows recaptured from the commingled groundwater. As shown in Table 10-1, TDS measured in

---

<sup>1</sup> Table 3-1, Current and Planned Water Supplies for City of Santa Maria

purchased SWP water varies between 97 ppm and 358 ppm for the years 2005 and 2006. TDS from the City of Santa Maria's wells is higher, ranging from 650 ppm to 1300 ppm. TDS levels in the water from the proposed wells are expected to be somewhere between these levels, because the City is importing softer water to the groundwater basin.

Additional investigation of groundwater quality is recommended. The construction of test wells would greatly improve the knowledge of the groundwater quality in the areas in question at the depths to be considered.

Because the makeup of groundwater strata within the Santa Maria River is not well defined, predicting the depths to river underflow<sup>2</sup> and native groundwater as well as the required well depth to intercept both supplies is difficult without site specific field exploration. The average depth to groundwater is 281 feet, with a range of 16 feet to 1,220 feet (DWR, 2002.) It is anticipated that construction of a well that intercepts groundwater from the underlying aquifer will also likely benefit from deep percolation of Twitchell water along the Santa Maria River bed in addition to SWP return flows.

Groundwater extracted from the proposed well sites may be a "commingled" mix of Twitchell water, SWP return flows, and possibly native groundwater. Therefore water quality at the proposed well sites may be influenced by all supplies of groundwater within the Basin. Prior to utilizing groundwater pumped from the Santa Maria Valley, the NCSD will need to further investigate groundwater quality within the vicinity of the proposed well sites. Also, due to the proximity of the Bonita and Hutton well sites to the river, applicability of the Surface Water Treatment Rule (SWTR) at these sites will need to be confirmed as discussed under *Regulatory Constraints*.

It is anticipated the NCSD may need to disinfect and filter the water. Filtration of extracted groundwater would only be necessary if the water was deemed to be under the influence of surface water, or if there was chemical contamination that would require treatment (such as arsenic or exceedance of a secondary MCL). In addition, the District must ensure compliance with the drinking water standards for disinfection byproducts (DBPs) and ensure maintenance of a disinfectant residual.

## Reliability

The City of Santa Maria's current water supply is derived, in part, from the groundwater supplies being considered in this analysis. The City of Santa Maria considers its water supply (including SWP water and associated return flows, Twitchell water, & native groundwater) to be 100 percent reliable through the year 2030. Reliability from SWP return flows is essentially the same as that of SWP water. See Section 4 for a discussion of SWP water reliability.

---

<sup>2</sup> Underflow is assumed to consist of Twitchell water and elements of SWP return flows

Obtaining Santa Maria Valley groundwater in any one year is reasonably reliable due to the large storage volume available, and because over long periods, annual rainfall totals are occasionally extremely high and therefore the likelihood of replacing groundwater pumpage in excess of the native yield is high (SAIC, 2007).

With regards to the reliability of the use of this groundwater by NCSD, it should be understood that the City's groundwater production has been significantly curtailed since receiving its first SWP water deliveries in 1997. Groundwater currently represents approximately 9% of its water supply, with a projected increase in the use of its groundwater to as much as 6,858 AFY in the year 2030.

Winter floodwaters captured annually at Twitchell Reservoir have been released into the Santa Maria River in all but three years since the implementation of the project in 1960. Therefore, Santa Maria River underflow provides a reasonable reliability to the annual supply for any one year (SAIC, 2007).

## Required Facilities

Based on this constraints analysis, the following facilities will be required to provide supplemental groundwater from the proposed well sites:

- Collector well field (approximately 4 wells for 3,000 AFY, 8 wells for 6,300 AFY);
- Water treatment to filter and disinfect "surface" water (at the Bonita and Hutton sites only – possibly not required at Oso Flaco Lake Road site);
- Storage;
- Transmission pipeline from proposed well site to existing NCSD distribution system at Tefft
  - Hutton Site: 4.3 miles of pipe; or
  - Bonita Site: 3.9 miles of pipe; or
  - Oso Flaco Lake Road Site: 5.3 miles of pipe
- Interconnection to existing 16-inch NCSD pipeline at Tefft

A schematic map of the Project is shown in Figure 3-1.

### Collector Well Field Options

Siting of the well field was considered at three sites: (1) Bonita and; (2) Hutton Road; (3) Oso Flaco Lake Road.

The Bonita Site is located on a 0.5-Acre site owned by NCSD in the Santa Maria Valley<sup>3</sup>. This site is immediately north of the San Luis Obispo/Santa Barbara County line near the northern Santa Maria

---

<sup>3</sup> NCSD owns an undeveloped well on this property (APN: 092-231-016).

River boundary. NCSD currently shares an easement with the adjacent SWP Coastal Branch pipeline to Riverside Road, however, it doesn't currently use this easement.

The Hutton Road Site is proposed to be located between the southernmost end of Hutton Road and the northern bank of the Santa Maria River. The Oso Flaco Lake Road Site is proposed to be located along Oso Flaco Lake Road just west of the intersection with Division Street. Neither of these sites is currently owned by NCSD.

### Treatment System

The proximity of both the Bonita and Hutton Sites to the Santa Maria River requires consideration of the CDHS Surface Water Treatment Rule (SWTR). Based on a review of CDHS's Criteria for Evaluation of Ground Water Sources as discussed under *Regulatory Constraints*, it is assumed that complete treatment under the SWTR will be required at these well sites, but may not be required at the Oso Flaco Lake Road site.

### Pipeline and Connection Location

The WIP Preliminary Engineering Memorandum (Boyle 2006) recommended the point of connection for supplemental water to be at Tefft and Oakglen. This same point of connection is recommended for this constraints analysis. In order to minimize lifecycle cost and pressure increases to NCSD's distribution system this connection point would require the installation of an 18-inch pipeline.

## **Implementation Schedule**

It is estimated approximately 4 to 6 years will be required to fully implement this project as described below:

- Negotiations and agreements for transfer of water rights: 1 to 2 years
- Installation of test wells and evaluation water quality: 1 year (concurrent with negotiation)
- Project design: 1 to 2 years and
- Procurement of permits: 2 years<sup>4</sup> (Padre, 2007) (concurrent with negotiation and design)
- Project construction: 1 to 2 years

## **Constraints**

### Institutional:

Institutional constraints for the proposed project are identified as follows:

---

<sup>4</sup> Per Padre Associates Environmental and Permitting Constraints Analysis

- NCSO should consider the final Judgment in the Santa Maria Groundwater Litigation (pending) prior to pursuing this alternative.
- The City of Santa Maria must be willing to sell a portion of their groundwater pumping rights to NCSO. The District will need to initiate negotiations with the City of Santa Maria and the Santa Maria Valley Water Conservation District (SMVWCD), the agency which owns and operates Twitchell Reservoir.
- NCSO must acquire property for the proposed well sites. NCSO must also acquire necessary easements for transmission pipelines.
- Attempting to acquire transfer of Twitchell Yield from any of the Twitchell Participants may require NCSO to financially participate in sediment removal from the reservoir. The Reservoir's useful life is questionable because sediment is filling at a rate higher than initially expected.
- SMVWCD has expressed concerns regarding the District withdrawing water from the proposed wells. They consider that water part of their Twitchell Reservoir release and part of their groundwater recharge flow. SMVWCD's AB3030 Groundwater Management Plan prohibits export of water from the basin.

Legal:

Legal constraints are summarized as follows:

- Extracting groundwater at the locations proposed may lower groundwater elevations, thereby reducing the quantity of groundwater flowing from SMVMA to NMMA, and also reducing the movement of groundwater from NMMA to the Northern Cities Management Area. This change would likely be prohibited by the Basin Adjudication.
- The Phase V Statement of Decision confirms the ability of the SMVWCD to allocate Twitchell Reservoir Yield in the manner provided in the Stipulation. Therefore, NCSO will need to enter into agreements with both the SMVWCD and the City of Santa Maria to acquire a transfer of Twitchell Yield. Furthermore, a memorandum of agreement summarizing each transfer must be filed with the Court and provided to the Twitchell Management Authority in accordance with the Stipulation.
- NCSO will need to carefully structure the transfer of water rights at either of the three proposed well site properties in order to protect the water rights of the overlying users.
- NCSO should avoid a "term" in its agreement if it pursues return flows. Instead, the District should pursue an agreement with the City of Santa Maria that gives NCSO the right to pump return flows so long as the City takes State Water.
- The City of Santa Maria has the right to install a new well in the SMVMA, but any well that NCSO installs outside the NMMA will require adjudication. Any transfer of water from the SMVMA to the NMMA will require adjudication.

### Regulatory:

- Twitchell Reservoir is operated under a State Water Resources Control Board license with restrictions on purpose (municipal / industrial) & place of use (within boundaries of Santa Maria Valley Water Conservation District). Use by NCS D may violate place of use restrictions without a permit amendment. Therefore, a place-of-use modification for Twitchell Reservoir will probably be required.
- The proximity of the Bonita and Hutton Sites to the Santa Maria River requires consideration of the CDHS Surface Water Treatment Rule (SWTR). Due to the proximity of both wells to the river, an evaluation is expected to show the source to be “Groundwater Under the Direct Influence” (GWUDI) of surface water, and that complete treatment under the SWTR may be required at both well sites. The Oso Flaco Road site is not expected to be categorized as a GWUDI source.
- Environmental review under CEQA must be initiated and completed for development of either of the well sites, and for the construction of the pipeline and storage facilities.
- Permits from the pertinent regulatory agencies must be secured prior to construction of any of the proposed facilities, including a discretionary development permit by the County of San Luis Obispo, permits from the USACE, RWQCB, and CDFG for any pipeline creek crossings, and a Caltrans encroachment permit for pipeline crossings at Highway 101, if crossed. NOAA Fisheries most likely will not be a key permitting agency under this alternative provided that surface water flows within the Santa Maria River are not affected.

### Cost:

The estimated annual costs, including debt service on capital costs and O&M, ranged from \$520/af (a 6,300 afy facility with minimal treatment at the Oso Flaco Road site) to \$770/af (a 3,000 afy facility requiring coagulation and filtration at the Bonita site). Assuming a purchase price from Santa Maria of \$1,250/af (the price for treated Santa Maria drinking water contained in the MOU for the Waterline Intertie Project), the total cost would be between \$1,770/af and \$2,020/af, plus costs for purchasing the Hutton or Oso Flaco Road site.

### Capacity:

As noted above, withdrawing significant quantities of groundwater from a location near the boundary between the SMVMA and the NMMA is likely to affect the movement of water from the SMVMA into the NMMA. Institutional and legal considerations would likely prevent the District from implementing such a withdrawal.

It may be possible for the NCS D to acquire sufficient groundwater pumping rights to provide the full supplemental water needs of 3,000 and 6,300 AFY from other locations within the SMVMA.

# 4.0 CCWA, State, or “Other” Water

## Introduction

The State Water Project (SWP) is a system of dams, reservoirs, power and pumping plants, canals, and aqueducts that conveys water from Lake Oroville to Southern California. The “Coastal Branch” of the SWP consists of water conveyance facilities built by the California Department of Water Resources (DWR) and regional distribution and treatment facilities constructed by the Central Coast Water Authority (CCWA).

Coastal Branch Phase I was completed in 1968. Phase II of the Coastal Branch was completed in 1997 and brings SWP water to San Luis Obispo and Santa Barbara Counties. Key facilities include the 43-MGD Polonio Pass Water Treatment Plant (PPWTP), approximately 143 miles of pipeline, and associated pumping plants and storage tanks. Individual components of the Coastal Branch were built by either the DWR or CCWA. However, CCWA is responsible for operating and maintaining the Polonio Pass Water Treatment Plant and all of the downstream Coastal Branch facilities.

The CCWA was established in 1991 and is presently composed of eight members, all of which are public agencies. Each vote on the CCWA Board of Directors is weighted in proportion to the entity's SWP Table A Amount contained in its original Water Service Agreement. (Although certain agencies subsequently amended their SWP Table A Amounts, their voting percentages remained unchanged.) (CCWA, 2007)

CCWA is a SWP contractor through Santa Barbara Flood Control and Water Conservation District (SBCFC & WCD). San Luis Obispo County Flood Control and Water Conservation District (SLOCFC & WCD) is also a SWP contractor. SWP contractors may request a maximum amount of water each year – the contractual “Table A” amount.

The SWP allocates deliveries in any year among its contractors based on “amounts” shown in Table A of the SWP contracts. However, full delivery of these “Table A Amounts” is not guaranteed. As noted in a DWR study of SWP delivery reliability:

*Table A is used to define each contractor’s portion of the available water supply that DWR will allocate and deliver to that contractor. The Table A amounts in any particular contract, accordingly, should not be read as a guarantee of that amount but rather as the tool in an allocation process that defines an individual contractor’s “slice of the pie.”*  
(DWR, 2006)

Therefore, for the remainder of this report we will use the term “Table A Amount” to indicate a numerical value that is used to allocate deliveries among SMP contractors.

During years when the SWP is unable to deliver all of its Table A Amounts, deliveries are cut back to a percentage of each contractor’s Table A Amount. Many SWP contractors have established SWP Table A Amounts in excess of their planned deliveries to act as “drought buffers.” For example, The City of

Santa Maria’s SWP Table A Amount is 16,200 AFY, plus a 10% drought buffer. Therefore, in a year when the SWP restricts deliveries to 75% of Table A Amounts, the City would receive 82.5% (75% + 7.5%) of its 16,200 AFY.

During those years that availability of SWP water exceeds project participants' demand, project participants can store drought buffer water (and unused Table A Amounts) either directly into a groundwater basin or on an in-lieu basis (i.e., by taking delivery of the drought buffer and reducing groundwater pumping by an equal amount). During dry years when availability of SWP water is less than CCWA project participants' demand, stored drought buffer water (and stored Table A Amount water) can be used to augment SWP deliveries. (CCWA, 2007)

The State "Turnback Pool," is an internal SWP mechanism that pools unused SWP supplies early in the year for purchase by other SWP contractors at a set price. The turnback pool mechanism is only for one-year sales of water. (CCWA, 2007)

Each Santa Barbara County participant in the CCWA project is a water purveyor or user located in Santa Barbara County. Their SWP Table A Amounts are listed below.

Agency	SWP Table A Amount (AFY)
City of Buellton	578
Carpinteria Valley Water District	2,000
Goleta Water District	4,500
City of Guadalupe	550
La Cumbre Mutual Water Company	1,000
Montecito Water District	3,000
Morehart Land Company	200
City of Santa Barbara	3,000
Santa Barbara Research Center	50
City of Santa Maria	16,200
Santa Ynez RWCD, ID#1	2,000
Golden State (formerly “Southern California”) Water Company	500
Vandenberg Air Force Base	<u>5,500</u>
SUBTOTAL	39,078
CCWA 10% Drought Buffer	<u>3,908</u>
SUBTOTAL	42,986
Goleta Water District additional Drought Buffer	<u>2,500</u>
TOTAL Contractual SWP Table A Amount	45,486



Each San Luis Obispo County water purchaser is a water purveyor or user located in San Luis Obispo County which obtained contractual rights from SLO County to receive water from the SWP. Their SWP Table A Amounts are listed below.

Agency	SWP Table A Amount (AFY)
Avila Beach Community Services District	100
Avila Valley Mutual Water Company, Inc.	20
California Men's Colony (State)	400
County of San Luis Obispo C.S.A. No. 16-1 - Shandon	100
County of San Luis Obispo Operations Center and Regional Park	425
City of Morro Bay	1,313
Oceano Community Services District	750
City of Pismo Beach	1,240
San Luis Coastal Unified School District	7
San Miguelito Mutual Water Company	275
San Luis Obispo County Community College District (Cuesta College)	<u>200</u>
SUBTOTAL	4,830
SLO County Drought Buffer	2,640
Annual Turn Back Sales	<u>17,530</u>
TOTAL Contractual SWP Table A Amount	25,000

The Coastal Branch aqueduct and Polonio Pass Water Treatment Plant were designed to deliver and treat the SWP Table A Amounts listed above, disregarding the drought buffers, Goleta's excess SWP Table A Amount, and SLO County's annual turn back sales. Design capacity = 39,078 + 4,830 = 43,908 AFY.

## Previous Studies and Documents

The following list summarizes the studies and documents referenced for this evaluation:

- Pipeline System Modeling: Tank 1 to Santa Ynez Pump Facility - Definition of Available Extra Capacity (Penfield & Smith, June 2005)
- 2005 Santa Barbara County Groundwater Report (Santa Barbara County Public Works, March 2006)
- The State Water Project Delivery Reliability Report 2005 Final (Department of Water Resources, April 2006)
- 2005 Urban Water Management Plan for Central Coast Water Authority, Draft (CCWA, October 2005)

- CCWA meeting minutes, agendas, and other information available on CCWA website: <http://www.ccwa.com/>
- Final Urban Water Management Plan for Goleta Water District (URS/GWD, December 2005)
- 2005 Urban Water Management Plan for City of Santa Maria, Public Review Draft (CH2MHill, February 2007)
- Contract Between the State of California Department of Water Resources and SBCFC & WCD for a Water Supply (1963)
- Contract Between the State of California Department of Water Resources and SLOCFC & WCD for a Water Supply (1963)
- American States Water Company and Golden State Water Company Securities and Exchange Commission Form 10-K (Fiscal Year Ending December 31, 2006)

## Acquisition Scenarios

This section considers constraints associated with obtaining supplemental water from the Coastal Branch of the SWP by way of the following scenarios:

- (1) Acquiring unused or excess SWP Table A Amount:
  - a. SLOCFC&WCD unused SWP Table A Amount (i.e., the drought buffer or the turn back pool)
  - b. SBCFC & WCD suspended SWP Table A Amount
- (2) Acquiring State water indirectly through purchase from CCWA project participants including:
  - a. Goleta Water District (GWD)
  - b. City of Santa Maria
- (3) Directly participating in the SWP/CCWA:
  - a. Purchasing SWP water as a CCWA Project Participant (outside of Santa Barbara County)
  - b. Purchasing SWP water as a San Luis Obispo County Water Purchaser
- (4) Acquiring “other” water through CCWA project participants including:
  - a. Purchase Golden State Water Company (GSWC) Natomas CVP entitlement in exchange for SWP water
  - b. Purchase City of Santa Maria water per MOU in exchange for SWP water

Water could be provided to the NCSD via a turnout along the Coastal Branch within the District's boundary. Water would then either be delivered directly to the District water system, or indirectly via aquifer storage and recovery (ASR). A schematic map of the proposed project is shown in Figure 4-1.

This constraints analysis does not consider the use of SWP "Article 21" water. Article 21 water is made available by the SWP during times that abundant water and conveyance capacity is available, typically between January and March of most years. However, use of this water is restricted to the service area of the contractor taking delivery, with one exception: *"Article 21 water may be delivered outside the service area of a participating contractor for storage so long as it is later returned for use in the service area."* (DWR, 2006) Therefore, while Article 21 water may be available, eventually it would need to be returned, and therefore is not considered a true source of supplemental water.



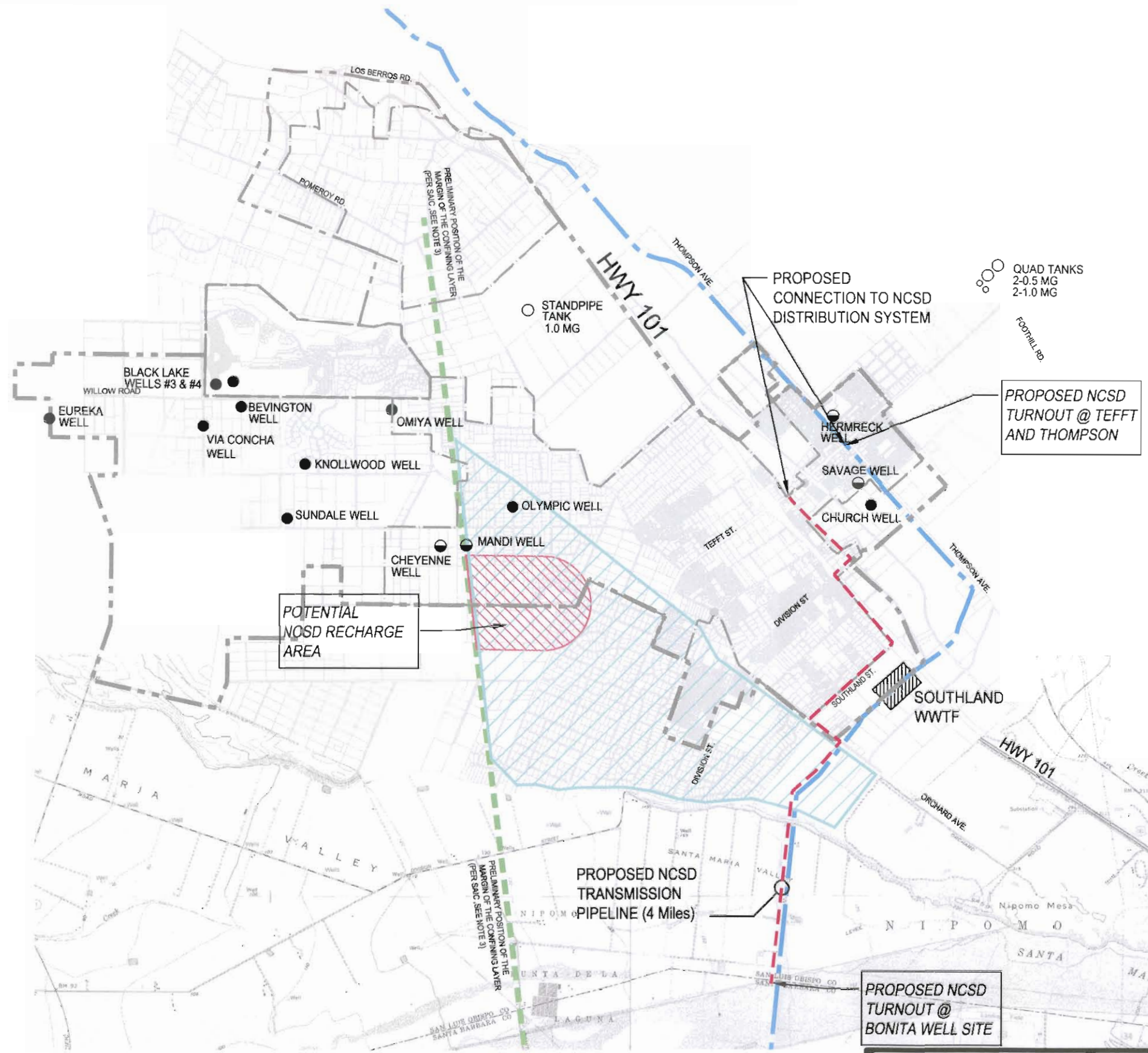





USER: cromo  
 DATE: Jun 11, 2007 8:47am  
 XREFS: BASE MAP  
 IMAGES: Map1.TIF  
 Well Sites  
 Parcel  
 SCAN4951\_000.LIT  
 C:\Users\cromo\Documents\19996.32 (Alternative Water Supply)\CAD\Design\Revised Figures and Plates\Figure 4-1\_C.C.W.A. State Other Water.dwg  
 DWG: W:\Nipomo CSD (19996)\19996.32 (Alternative Water Supply)\CAD\Design\Revised Figures and Plates\Figure 4-1\_C.C.W.A. State Other Water.dwg



**NOTES:**

1. POTENTIAL GROUNDWATER RECHARGE LOCATIONS ARE DERIVED FROM THE 2007 GTA EVALUATION OF POTENTIAL RECHARGE LOCATIONS.
2. PRELIMINARY TARGET AREA FOR RECHARGE IS DERIVED FROM THE 2007 SAIC TECH MEMO REGARDING YIELD OF AQUIFER STORAGE AND RECOVERY.
3. POSSIBLE LOCATION OF EASTERN MARGIN OF POSSIBLE CONFINING LAYER

**LEGEND**

-  POTENTIAL GROUNDWATER RECHARGE LOCATION (SEE NOTE 1)
-  PRELIMINARY TARGET AREA FOR RECHARGE - AQUIFER STORAGE AND RECOVERY OPTION (SEE NOTE 2)
-  NIPOMO CSD WELLS
-  NIPOMO CSD WELLS (STANDBY)
-  NIPOMO CSD TANKS
-  FUTURE WATER SYSTEM SERVICE AREA BOUNDARY
-  EXISTING WATER SYSTEM SERVICE AREA BOUNDARY
-  PROPOSED PIPELINE
-  EXISTING S.W.P. COASTAL BRANCH PIPELINE

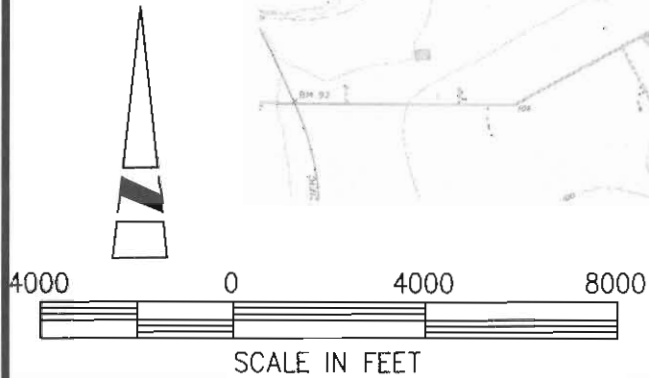

NIPOMO CSD EVALUATION OF SUPPLEMENTAL WATER ALTERNATIVES  
 C.C.W.A. STATE OR "OTHER" WATER

BEC PROJECT NO.  
 19996.32

FIGURE  
 4-1

## Supply

This section addresses the constraints associated with the SWP providing either 3,000 acre-feet per year (AFY) or 6,300 AFY under the scenarios listed above. Later sections address constraints associated with delivery and reliability of this supply, as well as institutional, legal, and cost issues.

### Scenario 1: Acquiring Unused or Excess SWP Table A Amount

Sufficient supply exists in the form of drought buffer or excess SWP Table A Amount, as shown below:

CCWA 10% Drought Buffer	3,908 AFY
Goleta Water District additional Drought Buffer	2,500
SLO County Drought Buffer	2,640
Annual SLO County Turn Back Sales	<u>17,530</u>
TOTAL Unused or Excess SWP Table A Amount	26,578 AFY

### Scenario 2: Purchase Water from CCWA project participants

Clearly, sufficient supply (in the form of existing SWP Table A Amounts) exists to meet the needs noted above. In most cases, a purchase arrangement would need to be made with two or more CCWA participants to provide 3,000 AFY. To provide 6,300 AFY, an arrangement with two or more participants would very likely be required, unless the entire amount can be provided by the City of Santa Maria.

### Scenario 3: Direct Participation in the SWP/CCWA

Acquiring a combination of CCWA's 10% drought buffer and GWD's additional drought buffer SWP Table A Amount could provide either 3,000 AFY or 6,300 AFY. Under this scenario the NCSD would become a SWP/CCWA participant through CCWA.

Acquiring a portion of SLO County's annual turn back sales could provide these same amounts. Under this scenario the NCSD would become a SWP/CCWA participant through SLOCFC&WCD.

### Scenario 4: Acquiring "Other" Water through CCWA Project Participants

ASWC/GSWC Natomas Entitlement to Central Valley Project Water:

The federally funded and managed "Central Valley Project" may also provide a supply of supplemental water through one of the existing SWP/CCWA participants, under two options described below.

The Golden State Water Company (GSWC) provides water service to Orcutt, Siskiyou, Lake Marie, and Tanglewood areas. American States Water Company (ASWC) is the parent company for GSWC and American States Utility Services (ASUS). ASWC, through its ASUS subsidiary, recently purchased permanent Sacramento River water diversion rights from the Natomas Central Mutual Water Company (Natomas), allowing ASWC to divert up to 5,000 acre-feet of Central Valley Project (CVP) water per year. (ASWC, 2007) Therefore, it may be possible to purchase this 5,000 AFY CVP entitlement from GSWC.

GSWC has also entered into a water transfer agreement with Natomas under which Natomas will supply GSWC with up to 30,000 AFY of water to be used exclusively by GSWC to serve a proposed new service area in Sutter County, California. (ASWC, 2007) In order to provide retail water service to this portion of Sutter County, GSWC has filed for a Certificate of Public Convenience and Necessity with the California Public Utilities Commission (CPUC). Review of this application has been deferred by the CPUC pending completion of an environmental assessment. It may be possible to purchase a portion of this water, and exchange it for some or all of the GSWA CVP entitlement.

#### City of Santa Maria Water:

The water supply for the City of Santa Maria is 49,710 AFY (CH2MHill, 2007). This supply includes: 13,706 AFY of purchased SWP water; 12,795 AFY of groundwater; 14,300 AFY of Twitchell yield/commingled groundwater; and 8,909 AFY of SWP return flows (i.e., water used for irrigation or other purposes which “returns” via deep percolation to the aquifer.) This supply is greater than projected demands. The city’s total projected water demand is estimated at 24,780 AFY in the year 2030, including the 3,000 AFY sold to NCSO and sales to other agencies. Therefore, adequate supply exists for the District to purchase “other” Santa Maria water in exchange for SWP water.

## **Unused and Excess Capacity for Treatment and Conveyance**

Implementation of any of these scenarios requires that the SWP/CCWA treatment and conveyance facilities have sufficient capacity to accommodate proposed deliveries to the NCSO. System capacity will not be an issue under Scenario 2 if the SWP Table A Amount or entitlement is purchased from CCWA participants downstream of NCSO and the delivered volume is equal to the water purveyor’s historically delivered SWP Table A Amount. However, system capacity will be an issue if NCSO requests delivery of a drought buffer Table A Amount, an unused Table A Amount, or some other water source, as is the case for the three other scenarios being considered.

The existing treatment and conveyance facilities were designed, constructed, and (in the case of the treatment plant) rated at a contracted capacity equal to the SWP Table A Amounts listed above (neglecting drought buffers, suspended amounts, and undeliverable capacity). Each portion of the system was designed with a small amount of unused capacity. Subsequent experience has shown that

the system is working more efficiently than designed, thereby providing some excess capacity beyond design requirements.

The following table summarizes the contracted, unused, and excess capacity in the existing CCWA treatment and conveyance facilities.

**Table 4-1 Capacities of the CCWA Treatment and Conveyance Facilities**

<b>Facility</b>	<b>Polonio Pass Water Treatment Plant</b>	<b>Pipeline above Lopez Dam</b>	<b>Pipeline from Lopez Dam to Santa Maria</b>
Contracted Capacity	43,908 AFY	43,908 AFY	39,078 AFY
Unused Capacity	0 AFY (a)	3,908 AFY (b)	3,908 AFY (b)
Excess Capacity	5,000 AFY (d)	5,600 to 9,100 AFY (c)	up to 5,600 AFY (c)

(a) CCWA web site shows WWTP design capacity of 43 MGD, giving 44,000 AF in 11 months, a value within the rounding error of contracted capacity.

(b) Penfield & Smith (2005) analysis using design assumptions.

(c) Penfield & Smith (2005) analysis using calibrated model. Pipeline capacities above and below Lopez turnout depend on volume released at Lopez.

(d) "CCWA has determined that the treatment capacity at the Polonio Pass Treatment plant is approximately 5,000 AFY greater than its current permitted rating." City of Santa Maria, Urban Water Management Plan (2007) page 3-13.

## Quality

The SWP Coastal Branch conveys surface water which is treated to DHS drinking water standards at the Polonio Pass Water Treatment Plant using advanced coagulation, activated carbon filters, chlorine, and chloramines. Algae; taste and odor; and disinfection byproduct formation are potential water quality issues that may affect SWP participants (CCWA, 2005).

Because NCS D currently disinfects its groundwater with free chlorine and the SWP supplemental water uses chloramines, provisions must be made to either convert the SWP water over to free chlorine residual, or convert NCS D groundwater over to chloramine residual (Boyle 2006).

## Reliability

### State Water Project

The reliability of State Water Project (SWP) supplemental water will depend on the quantity of water obtained from the SWP (or the CVP), and on the amount of conveyance and treatment capacity obtained from the CCWA.

Being dependent on Northern California hydrological conditions, the SWP is not always able to provide the entire Table "A" amount to all its contractors. In such cases, deliveries are allocated to each contractor based on their Table "A" amount. The probability of receiving SWP deliveries has been estimated in the year 2025, and is summarized in the following figure.

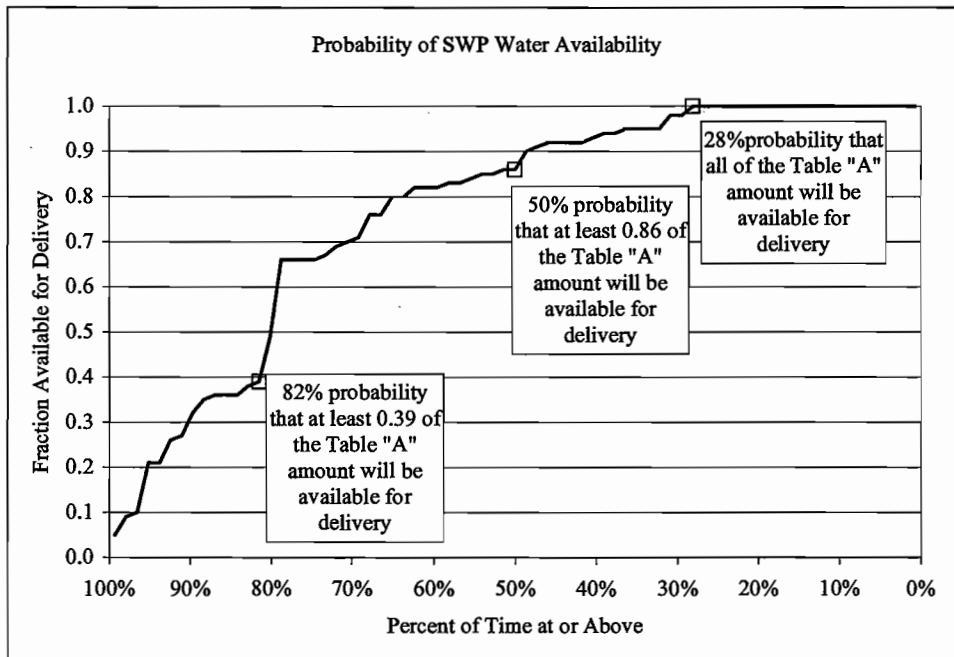

**Figure 4-2 SWP Delivery Reliability**

Source: The State Water Project Delivery Reliability Report 2005, April 2006.

Predicted SWP water deliveries to San Luis Obispo County participants and CCWA participants in Santa Barbara County are dependent on the reliability of the SWP supply and the available CCWA conveyance and treatment capacity (SAIC, 2007), as summarized below.



**Table 4-2 Predicted SWP/CCWA Water Deliveries**

Year Type	San Luis Obispo County		Santa Barbara County	
	Available from SWP (1)	Delivered	Available from SWP	Delivered
“Wet” Year	24,000 AFY	4,830 AFY <sup>(2)</sup>	43,500 AFY	39,078 AFY <sup>(2)</sup>
50% Probability	21,000	4,830	38,000	38,000
Long Term Average	19,000	4,830	34,500	34,500
“Dry” Year	16,500	4,830	29,500	29,500

(1) based on full 25,000 AFY Table A Amount held by San Luis Obispo County.

(2) Limited by pipeline and treatment design capacity, although unused and excess capacity may be available, as discussed above.

It is evident that the reliability of any supplemental SWP water will depend on its SWP Table A Amount (including drought buffer), and on the contracted portion of the treatment and conveyance capacity within the CCWA.

Central Valley Project

The reliability of water obtained from the Central Valley project via the Natomas Central Mutual Water Company is assumed to be similar to the reliability of CVP water as a whole. The reliability of CVP deliveries is similar to the SWP, as shown below.

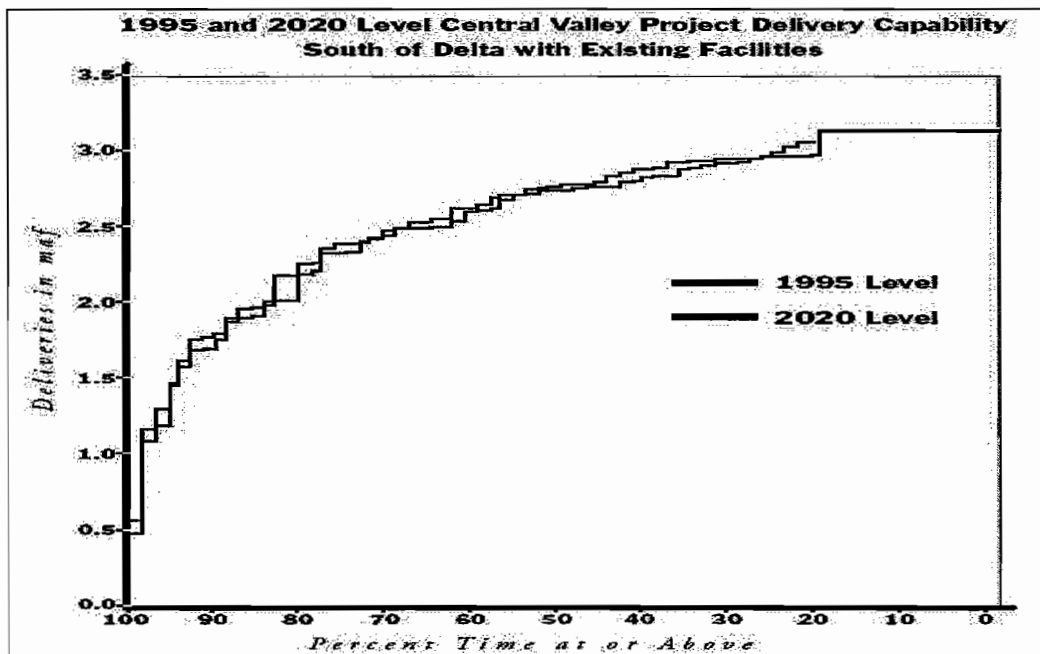

**Figure 4-3 CVP Delivery Reliability**

Source: California Water Plan, Bulletin 160-98,

It has been estimated that in 2020 during “drought” years (defined as the 1990-91 water years, an event with a recurrence interval of about 20 years, or a 5 percent probability of occurring in any given year) the CVP as a whole will be able to deliver 70% of its historical “average” deliveries (DWR, 1998).

## Required Facilities

Two physical options to provide supplemental SWP water within the Nipomo CSD study area were considered in this Constraints Analysis. They are as follows:

- Connect the District water system directly to the SWP Coastal Branch; and
- Provide facilities for aquifer storage and recovery (ASR) of SWP water

For the direct connection option, it is anticipated the supplemental water transmission system may originate from a proposed CCWA turnout near the intersection of Tefft Street and Thompson Road or the Bonita Well Site as shown on Figure 4-1. Depending on the final turnout location and disinfection alternative pursued, water treatment, conveyance, and interconnection facilities will also be required for this option.

Implementation of the ASR option will also require a turnout as identified above. Additionally, percolation and/or injection sites in addition to pumping facilities will also be required. It may be possible to incorporate percolation functions into existing or planned facilities, such as over-irrigation of landscaped areas or seasonal percolation through stormwater detention basins. The feasibility of direct injection would have to be evaluated with test facilities. The main concern would be clogging of the aquifer, thus reducing the aquifer transmissivity, over time due to the high nutrient loading from the excess nitrogen present due to the ammonia content in the chloramines in treated CCWA water. (A more detailed description of this option will be provided in Tech Memorandum No. 2.)

### Project Components for Direct Connection:

The following facilities will be required for a direct connection to the SWP Coastal Branch Pipeline:

- Turnout facility (including all required appurtenances) from existing 42-inch SWP pipeline at either Tefft and Thompson or at Bonita Well Site;
- Pipeline extension from turnout to existing NCSO distribution system as follows:
  - Turnout at Tefft and Thompson: 0.5 miles of pipe; or
  - Turnout at Bonita Well site: 4.2 miles of pipe
- Water treatment/disinfection facilities as follows:
  - Facilities upstream of interconnection to NCSO system to convert SWP water to free chlorine residual; or

- Facilities at each well to convert NCSW wells to chloramine residual
- Interconnection to existing NCSW distribution system

Project Components for ASR:

The following facilities will be required for using supplemental SWP water in an aquifer storage and recovery program:

- Turnout facility (including all required appurtenances) from existing 42-inch SWP pipeline at either Tefft and Thompson or at Bonita Well Site;
- Pipeline extension from turnout to proposed spreading pond facilities or injection facilities;
- Water treatment facilities (if required) upstream of direct injection facilities;
- Spreading ponds (dimensions and preferred location(s) will be conceptually reviewed in Technical Memorandum No. 2);  
[Assuming a 6 inch per day percolation rate, and adequate time for pond rotation for drying and maintenance, approximately 50 acres of pond would be sufficient to percolate 6,300 AFY (SAIC, 2007). Likewise, 24 acres of pond would be required to infiltrate 3,000 AFY.]
- Recovery well field and/or upgrades to existing wells (expected recovery rates will be conceptually reviewed in TM No. 2); and
- Pipeline extension from recovery well field to interconnection with existing NCSW distribution system (if required)

**Implementation Schedule**

Assuming the NCSW moves aggressively to obtain agreements with other agencies, it is estimated approximately 4 to 6 years will be required to fully implement this project. This estimate is based on the following:

- |   |                  |
|---|------------------|
| ● Obtain tentative agreement from providing agency and from CCWA                | 0.5 to 1.5 years |
| ● Hold special election to obtain agreement of NCSW rate payers                 | 1.0 to 0.5 years |
| ● Site specific investigation of feasibility of percolation or direct injection | 0.5 to 1.0 years |
| ● Design, Permitting, and Environmental Review                                  | 1.0 to 1.5 years |
| ● Construction and Start Up   | 1.0 to 1.5 years |

## Constraints

This section presents an analysis of constraints to obtaining supplemental water from the SWP (or other sources) through the Coastal Branch aqueduct under the following scenarios:

- Acquire unused or excess SWP Table A Amounts from CCWA or SLOCFC&WCD;
- Acquire State Water indirectly through purchase from CCWA project participants (Goleta Water District or City of Santa Maria);
- Directly participating in the SWP/CCWA as either a project participant contracted through CCWA or a water purchaser contracted through SLOCFC&WCD; or
- Acquire “other” water through CCWA project participants (GSWC/Natomas or City of Santa Maria)

### Institutional

Any transfer of permanent entitlement from one state water contractor to another requires more than CCWA approval. A transfer would also require SLO County Board of Supervisors, Santa Barbara County Board of Supervisors, and DWR approvals. Therefore, the opinions of many people and the policy deliberations of many elected officials will need to be addressed. NCSD’s desire to not pay past costs may be in conflict with State Water contracts, depending on the specifics. (Ogren, pers. comm.)

There exists competing interest among existing project participants with regards to available unused/excess capacity in SWP/CCWA facilities as well as unused Table A allotments.

- CCWA is interested in acquiring SLOCFC & WCD’s unused SWP Table A Amount as additional drought buffer to improve water delivery reliability.
- SLOCFC & WCD has developed a proposed policy regarding transfer/sale of its SWP Excess Entitlement. Policies that may hinder NCSD’s bid for some of this water include:
  - Existing local Project Participants have first right to utilize excess entitlement for reliability purposes. NCSD is not currently a contracted Project Participant.
  - Interested agencies may be required to “buy into” the District’s past costs.
- Both CCWA and the City of Santa Maria are interested in SLOCFC&WCD’s suspended Table A allotment of 12,214 AFY. It is understood CCWA is actively pursuing a possible repurchase of this allotment for reliability purposes.
- California Department of Water Resources owns the Coastal Branch Pipeline from Tank No. 1 to Tank No. 5 on Vandenberg AFB, however, CCWA is responsible for operating and maintaining it. Furthermore, CCWA owns and operates the Polonio Pass Water Treatment Plant at the State’s Tank No. 1 site as well as the 42-mile pipeline extension from Vandenberg AFB to Lake Cachuma. Therefore, it is possible that CCWA could block any agreement between NCSD and

existing project participants for SWP or “other” water. This includes the proposed purchase of Natomas entitlement from GSWC.

### Reliability

The long-term rate of delivery for any SWP Table A Amount is approximately 76 %. Reliability for CVP water is similar. Therefore, additional SWP Table A Amounts for “drought buffer” would be required to improve the reliability of this proposed supply.

### Conveyance and Treatment Capacity

The City of Santa Maria, among others, is interested in acquiring tentative additional treatment capacity at Polonio Pass WTP. This is contingent on CCWA’s successful re-rating of the plant’s filters.

- The City of Santa Maria is also interested in acquiring the additional 5,000 AFY available for delivery at the City’s turnout as identified in the 2005 P&S Capacity Study and the City’s UWMP. This is the additional capacity that could be available for existing project participants and/or Nipomo CSD as discussed in the analysis.
- GSWC’s entitlement to 30,000 AFY of Natomas water is intended to serve a proposed new service area in Sutter County. GSWC has filed for a Certificate of Public Convenience and Necessity with the California Public Utilities Commission (CPUC) in order to provide retail water service to this area. It is understood that Rob Saperstein of Hatch & Parent (attorney for GSWC) is currently conducting an analysis that may address both the institutional and legal feasibility for procuring this water. Furthermore, delivery of any portion of this water through the SWP pipeline to NCSD will be restricted by limitations in available pipeline capacity and the City of Santa Maria’s mutual interest in acquiring the same as discussed above.
- The City of Santa Maria is opposed to providing NCSD exchange water through a connection to the SWP pipeline within District boundaries. This is their “higher quality” surface water used for blending with pumped groundwater.
- Goleta Water District’s additional 2,500 AFY of SWP allotment might be available on a “short term” basis when the District’s projected or actual supplies exceed its demand and ability to inject groundwater. However, delivery of any portion of this water is also constrained by limitations in available pipeline capacity and the competing interest for the same as discussed above. NCSD must decide if a “term” contract with GWD is acceptable.

### Legal:

Following a meeting with NCSD staff and its legal counsel, it is understood that the District desires to avoid: (1) “term” contracts for obtaining water from existing participants; and (2) buying into SWP construction costs. The following legal constraints attempt to summarize the necessary instruments, agreements, and contracts required for obtaining supplemental water from the SWP pipeline.

- A prior voter referendum regarding NCS D involvement in the State Water Project specified that the District would not contract with the State DWR for State Project water. Therefore the District should require a public vote prior to pursuing any supply option involving CCWA/SWP facilities to convey supplemental water to NCS D.
- As previously indicated, Hatch & Parent (attorney for GSWC) is currently conducting an analysis that may address the legal requirements for NCS D's procurement of a portion of the Natomas water. The legal and contractual terms are currently pending.
- In order to acquire a portion of SBCFC & WCD's suspended 12,214 AFY amount, NCS D will likely need to enter an agreement with both CCWA and the DWR requiring it to pay costs with interest associated with the water.
- NCS D will likely need to enter an agreement with both SLOCFC & WCD and CCWA in order to acquire a portion of SLOCFC & WCD's unused SWP Table A Amount. As described in San Luis Obispo County's Excess Entitlement Policy, NCS D may be required to "buy into" their past costs. Furthermore, since San Luis Obispo County participated in construction of treatment and conveyance facilities for only 4,830 AFY, it is assumed NCS D may also be required to "buy into" a portion of other project participant's construction costs.
- Because existing CCWA Project Participants are provided with SWP water in accordance with their respective agreements with CCWA, NCS D will likely need to obtain their approval and/or enter an agreement with CCWA for any other scenario considered in this evaluation.

### Regulatory

- NCS D will also need to satisfy the requirement of a Title 22 Engineering Report for DHS/RWQCB review if aquifer storage-recovery is pursued.
- The construction of a treatment system, pipelines (including multiple stream crossings), and pumping facilities will require permits from local, state, and federal agencies.

### Cost

The estimated annual costs for construction and operation of a turnout, pipeline extension, and treatment facilities for a direct connection, including debt service on capital costs and O&M are \$380/af with a 3,000 afy facility, and \$130/af with a 6,300 afy facility.

Purchase of water from a willing seller will involve an agreement on two cost components: (1) annual costs for CCWA operation, maintenance, and continuing debt service; and (2) buy-in cost for past capital improvement payments made by the seller. For the purpose of this analysis we estimate per acre-foot rates will be similar to those in a recent sale of 400 AFY from Carpinteria Valley Water District. In that sale, annual costs were \$1,500/af and initial buy-in costs ("one time" fee) were \$5,000/af. (CVWD, 2006)

Therefore buy-in cost would be \$15 million for a 3,000 AFY facility and \$31.5 million for a 6,300 AFY facility. Financing these costs over 20 years at 6% would result in annual costs equivalent to \$436/AF, bringing the total cost to \$2,310/AF for a 3,000 AFY facility and \$2,070/AF for a 6,300 AFY facility.

### Capacity

There is not enough excess or unused delivery capacity in the CCWA conveyance and treatment facilities, nor are there sufficient excess SWP Table A Amounts available to satisfy the NCS D's need for 3,000 AFY or 6,300 AFY, plus the competing interests for the same water as summarized above under *Institutional Constraints*.

- Assuming full delivery of project participant allotments including drought buffers, the SWP pipeline upstream of the Lopez turnout doesn't have enough extra capacity to convey the full SLOCFC & WCD's unused Table A allotment of 20,170 AFY. According to the 2005 P&S Capacity Study, only 9,100 AFY (13.7 cfs) of additional water can be added to the pipeline between Tank No. 1 and the Lopez Turnout where it would be subsequently removed.
- Assuming full delivery of project participant allotments including drought buffers, the SWP pipeline both upstream and downstream of the Lopez Turnout and serving CCWA participants in Santa Barbara County doesn't have enough extra capacity to convey the full SBCFC & WCD's suspended Table A allotment of 12,214 AFY. According to the 2005 P&S Capacity Study, only 4,700-5,600 AFY of additional water can be added to the pipeline between Tank No. 1 and Santa Maria Valley. This is the additional capacity that could be available for existing project participants and/or Nipomo CSD as discussed in the analysis.
- Assuming full delivery of project participant allotments only (no drought buffers), CCWA's Polonio Pass WTP may have only 4,260 AFY<sup>5</sup> of available capacity at the current plant rating of 43-MGD. The WTP may have an additional capacity of 5,000 AFY if it is successfully re-rated by CCWA.

### Available Storage:

It has been estimated that the aquifer underlying the NMMA has available storage on the order of 400,000 AF. However, it is possible that hydrogeology considerations limit the area available for percolation ponds to approximately one-quarter of the 20,000 acres in the NMMA. Percolation of up to 6,300 AF within this area would likely raise the groundwater elevations by 10 feet over the 5,000 acres without consideration for likely lateral flow (SAIC, 2007). Therefore, adequate storage exists for the quantities under consideration.

---

<sup>5</sup> This is equivalent to 3,905 AFY on an 11-month basis.

# 5.0 Desalination of Sea Water/Cooling Water

## Introduction

Desalination of seawater or brackish groundwater could provide the District with a reliable source of additional water. Key factors in the implementation of this approach are the source of the saline water, the location where it will be treated, and where the brine is disposed. For this analysis, three distinct combinations of source, treatment, and disposal are examined:

**Table 5-1 Desalination Alternatives**

Alternative	Water Source	Treatment Location	Brine Disposal
Partner with Nipomo Refinery	Seawater/brackish water from new wells located on Nipomo Refinery land and “used” Nipomo Refinery cooling water	Nipomo Refinery	Additional capacity in existing Nipomo Refinery outfall through desalination of “used” cooling water.
NCSD Owned Facility	New beach wells	South of State Parks land	New ocean outfall or beach injection
Partner with SSLOCSD with Added NCSD Pipeline	New beach wells located in Oceano	Adjacent to SSLOCSD Wastewater Treatment Plant in Oceano	New District-built ocean outfall or beach injection

These alternatives are briefly described below.

### Partner with Nipomo Refinery

*<References to the “Nipomo Refinery” option are based on earlier investigations and conceptual analysis regarding this option. A more complete constraints analysis is being performed by another consultant to the District. Therefore, if needed, this section may be revised based on the pending report.>*

The Nipomo Refinery was built in 1955 and is designed to provide feedstocks for the San Francisco Refinery. Crude oil is transported by pipeline to the refinery, where it is run through the crude distillation units which have a rated input capacity of 44,400 barrels a day. Manufacturing operations are continuous, 24 hours per day, 365 days per year, except for yearly maintenance and repair shutdowns. (CRWQCB, 2002)



The refinery pumps 800-850 gpm of groundwater for cooling water and discharges 300 gpm of blowdown water and other wastewaters to an existing outfall. (Kennedy/Jenks, 2001.) Treatment of this blowdown water is a key component of this water supply alternative.

“Most industrial cooling towers use river water or well water as their source of fresh cooling water. The large mechanical induced-draft or forced-draft cooling towers in industrial plants such as power stations, petroleum oil refineries, petrochemical plants and natural gas processing plants continuously circulate cooling water through heat exchangers and other equipment where the water absorbs heat. That heat is then rejected to the atmosphere by the partial evaporation of the water in cooling towers where upflowing air is contacted with the circulating downflow of water. The loss of evaporated water into the air exhausted to the atmosphere is replaced by "make-up" fresh river water or fresh cooling water. Since the evaporation of pure water is replaced by make-up water containing carbonates and other dissolved salts, a portion of the circulating water is also continuously discarded as "blowdown" water to prevent the excessive build-up of salts in the circulating water.” (Beychok, 1967, in Wikipedia)

Another key component of this alternative will be utilization of the existing ocean outfall. All process wastewaters and contaminated storm water are collected and treated in a central wastewater treatment facility. This wastewater treatment facility is designed to treat 575,000 gallons per day (approximately 400 gpm). The final treated wastewater discharge is discharged to the Pacific Ocean through an outfall terminating 1,700 feet offshore and 27 feet deep. The discharge has not caused a violation of water quality standards to date, and based on past monitoring results, degradation of the marine environment has not occurred. (CRWQCB, 2002)

The alternative being evaluated would involve:

1. desalination of a portion of the cooling water before it enters the Nipomo Refinery wastewater treatment plant, thereby making additional capacity available in the outfall; or
2. desalination of seawater from new beach wells or brackish water from new wells at an undetermined location, and
3. disposal of the brine in the existing Nipomo Refinery ocean outfall.

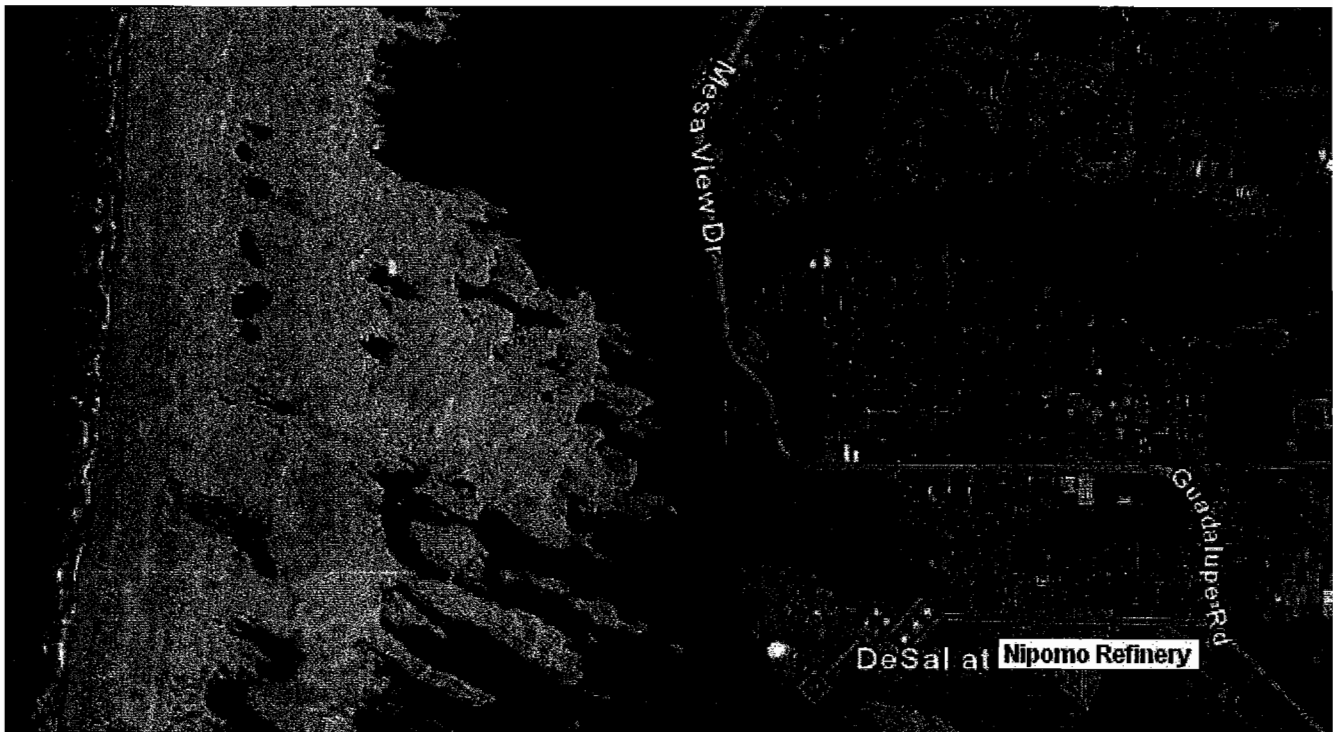

**Figure 5-1 Partner with Nipomo Refinery Desalination Alternative**

### **NCSD Owned Facility**

This alternative would involve construction of a stand-alone desalination facility, new beach intake and disposal wells, and associated pipelines. For evaluation purposes the desalination plant is assumed to be located on Highway 1 between Oso Flaco road and the Santa Maria River, the intake and brine lines are assumed to pass through the dunes south of State Park lands to the ocean, and the pipeline for the product water runs north up Highway 1 to connect with NCSD pipe network near the Eureka well site. See Figure 5-2.

In the case of an NCSD-owned facility, less environmental impacts, quicker environmental review, and greater likelihood of Coastal Commission approval would be associated with beach wells or other subsurface facilities, rather than direct ocean connections, for both intake and brine disposal. To implement this option the District will need to verify that adequate separation is provided between extraction and injection wells such that the injected brine does not impact the extraction water quality.

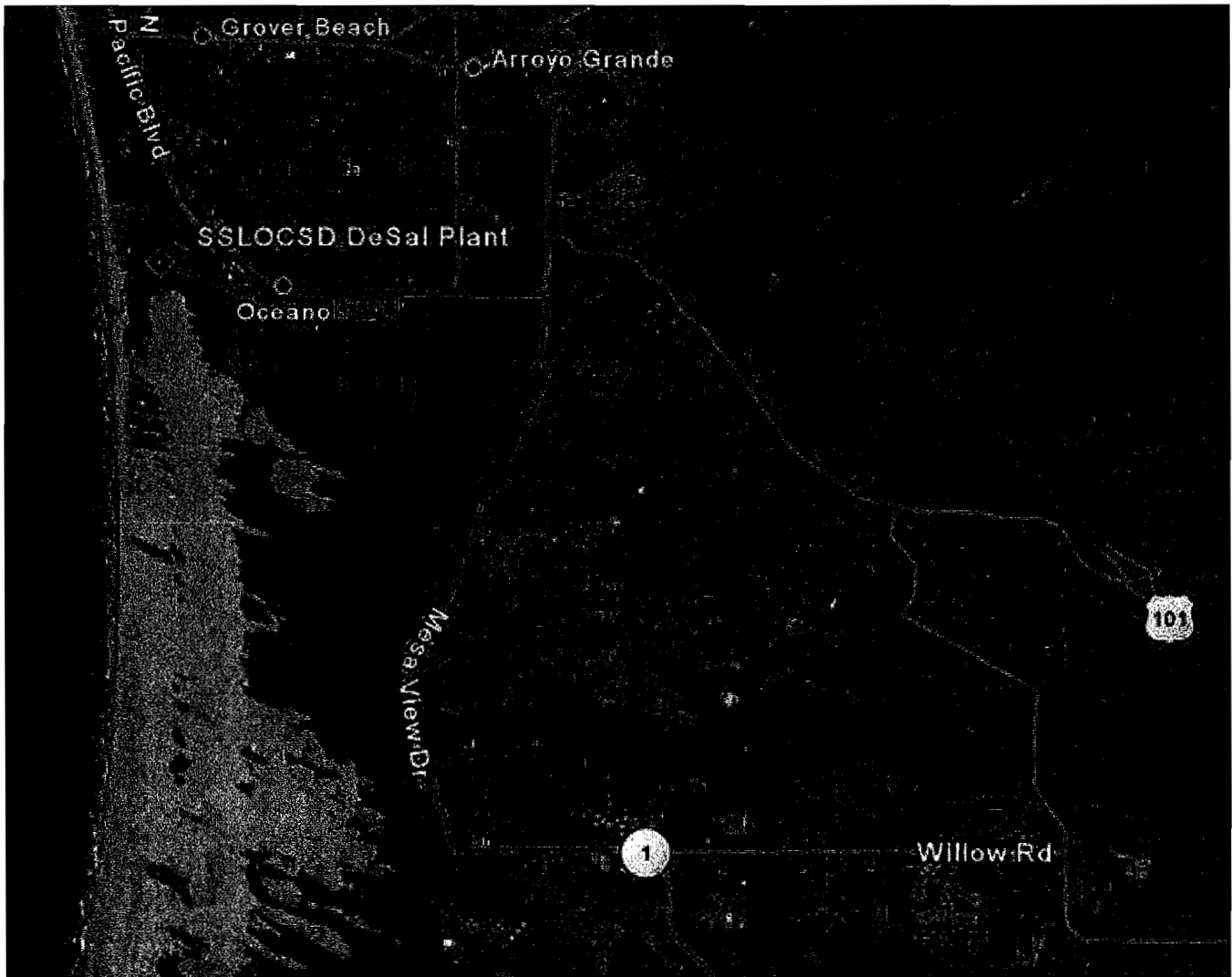

**Figure 5-2 Stand-alone Desalination Alternative**

**Partner with SSLOCSD with Added NCSD Pipeline**

This alternative would involve partnering with the cities of Arroyo Grande and Grover Beach, and with the Oceano Community Services District to expand their planned desalination facility at the South San Luis Obispo Community Services District (SSLOCSD) wastewater treatment plant. Unfortunately, it has been reported that the water needs of the SSLOCSD are such that the planned project (for SSLOCSD only) will utilize all the excess capacity in the existing ocean outfall. This lack of excess capacity will require the NCSD to build and permit a new brine disposal facility to accommodate the expanded desalination facility. As noted above, it may be possible to use beach injection to dispose of the brine.

For evaluation purposes it is assumed the pipeline for the product water runs south along Highway 1 to connect with NCSD pipe network near the Eureka well site. See Figure 5-3.



**Figure 5-3 Partner with SSLOCSD Desalination Alternative**

## **Previous Studies**

Previous studies have been made of the alternatives under consideration, as discussed below.

### **Partner with Nipomo Refinery – Previous Studies**

A 2001 report by Kennedy/Jenks Consultants looked at treating the used blowdown water for re-use as cooling water in the refinery. This additional treatment would reduce Nipomo Refinery need for groundwater by approximately 360 AF/yr. The cost for this source was estimated to be \$2,161 /AF

based on year 2001 capital costs of \$4 million (excluding land purchase) amortized over 20 years at 8% plus \$400,000/year O&M costs.

At the time of this writing (5/9/07) Cannon Associates is preparing a water supply feasibility study utilizing Nipomo Refinery cooling tower effluent, Nipomo Refinery groundwater, brackish/sea water from new NCSD wells, and reverse osmosis treatment. The memo is in draft form, and has not yet been reviewed by Nipomo Community Services District (NCSD).

### **NCSD Owned Facility – Previous Studies**

Boyle is unaware of any previous studies of a proposed NCSD owned seawater desalination facility.

However, numerous studies have been performed regarding construction of seawater desalination facilities for various municipalities and water Districts in California. As of 2004, the California Coastal Commission noted that there were 11 existing seawater desalination facilities on the California coast, with a combined capacity of approximately 3 MGD, or 3,300 afy. At that time, an additional 21 facilities were proposed, with a combined capacity of 240 MGD, or 260,000 afy (CCC, 2004).

### **Partner with SSLOCSD – Previous Studies**

A 2006 report by the Wallace Group looked at the feasibility of desalinating seawater at the South San Luis Obispo County Sanitation District (SSLOCSD) wastewater treatment plant, installing new beach wells for intake and utilizing the existing outfall for brine disposal. Key findings of that report include:

- Approximately 2 MGD (approx 2300 AFY) could be produced.
- Assuming a 50% recovery rate, the projected brine effluent flow rate (2 MGD) would utilize all excess capacity in the existing wastewater treatment plant outfall.
- Capital costs would be \$17.5 million. (December 2005 dollars.)
- Annual O&M costs would be \$4.5 million, assuming energy costs at \$0.15/kwh.
- Assuming a 20-year life cycle and 7% interest, water cost would be \$2,400/afy.

## **Supply**

Desalination using the Pacific Ocean as a source would allow for a virtually unlimited water supply, subject to limits imposed by regulatory agencies. These limits are unknown at this time, but for purposes of this screening analysis, are considered unlikely to restrict the amount of water that could be produced to amounts less than those noted above.

## **Partner with Nipomo Refinery – Supply**

*<This section will be completed pending the completion of the study being prepared by Cannon Associates.>*

## **NCSD Owned Facility – Supply**

Construction of an NCSD-dedicated facility would allow for a virtually unlimited water supply, subject to limits imposed by regulatory agencies.

## **Partner with SSLOCSD – Supply**

According to the water supply study recently completed for Oceano CSD, the City of Grover Beach, and the City of Arroyo Grande, a desalination facility built at the SSLOCSD WWTP to meet the water needs of these agencies would utilize all excess capacity in the existing wastewater treatment plant outfall. Therefore, existing discharge capacity is a constraint on supply for this alternative. Additional discharge capacity would need to be installed for the NCSD to process the additional product water needed. Additional beach wells or other inlet facilities would need to be installed and intake, conveyance, and discharge facilities would need to be enlarged to accommodate the increased flows foreseen.

## **Quality**

Typical product water recovery rates of 45% are reported for reverse osmosis seawater desalination plants on the California coast. Product water quality for these plants is between 284 and 400 ppm TDS. In addition, the RO process can remove unwanted contaminants, such as trihalomethane-precursors, pesticides, and bacteria (CCC, 2003). If the District chooses brackish water or beach well desalination, the lower TDS should result in higher recovery.

There is concern regarding the quality of cooling water due to the anti-scalant chemicals added. NCSD must be able to demonstrate that these chemicals are nontoxic to humans and can be removed in the treatment process.

Additional constituents of concern in sea water include algal toxins, such as domoic acid, and boron, which is not well removed by RO. RO treated water is also highly corrosive and must include provisions for corrosion control.

## Reliability

The reliability of these alternatives is considered very high. Temporary interruptions in service may occur due to power outages or maintenance or repairs to supply and delivery lines, but the source itself – the Pacific Ocean – can be considered a reliable source for the foreseeable future.

## Required Facilities

Based on this constraints analysis, the facilities required to obtain seawater or brackish water, treat it, dispose of the waste, and transport the treated water to the NCSD distribution system are listed below for production of 3,000 afy and 6,300 afy.

**Table 5-2 Facilities Required for Desalination Alternatives – 3,000 afy**

Alternative	Intake Structure	Intake Pipeline	Treatment Plant	Delivery Pipeline
a. Partner with Nipomo Refinery	7 Brackish or Beach Wells	24 inch diameter 1 mile	3,000 afy (2.7 MGD)	18 inch diameter 1.9 miles
b. NCSD Owned Facility	7 Beach Wells, 0.9 mgd each	24 inch diameter 3.8 miles	3,000 afy (2.7 MGD) plus 3.8 mile 18” discharge line and ocean outfall	18 inch diameter 3.6 miles
c. Partner with SSLOCSD with Added NCSD Pipeline	7 additional Beach Wells, 0.9 mgd each	Enlarge planned SSLOCSD intake pipeline	Enlarge SSLOCSD facility by 2.7 MGD plus 0.4 mile 18” discharge line and ocean outfall	18 inch diameter 7.8 miles

**Table 5-3 Facilities Required for Desalination Alternatives – 6,300 afy**

Alternative	Intake Structure	Intake Pipeline	Treatment Plant	Delivery Pipeline
a. Partner with Nipomo Refinery	15 Brackish or Beach Wells	36 inch diameter 1 mile	6,300 afy (5.7 MGD)	24 inch diameter 1.9 miles
b. NCSD Owned Facility	15 Beach Wells, 0.9 mgd each	36 inch diameter 3.8 miles	6,300 afy (5.7 MGD) plus 3.8 mile 24” discharge line and ocean outfall	24 inch diameter 3.6 miles

c. Partner with SSLOCSD with Added NCSD Pipeline	15 additional Beach Wells, 0.9 mgd each	Enlarge planned SSLOCSD intake pipeline	Enlarge SSLOCSD facility by 5.7 MGD plus 0.4 mile 24" discharge line and ocean outfall	24 inch diameter 7.8 miles
--	---	---	--	-------------------------------

## Implementation Schedule

Given the time needed for cooperation between agencies/facility owners, extensive environmental review, pilot testing, field investigations, design, construction, and startup, it is expected that implementation of any of these alternatives would take between 6½ and 10½ years. This estimate is based on the following:

- Obtain agreement from cooperating entities 0.5 to 1.5 years
- Pilot studies of treatment options and Concurrent field investigations of intake/disposal options 1.0 to 1.5 years
- Design 1.0 to 1.5 years
- Permitting and environmental review 3.0 to 4.5 years
- Construction and Start Up 1.0 to 1.5 years

## Constraints

### Institutional

Institutional constraints for the proposed project are identified as follows:

- If the District decides to partner with SSLOCSD, then the NCSD should promptly notify SSLOCSD (Oceano CSD and the cities of Arroyo Grande and Grover Beach) of its intentions and receive approval from the existing project participants. They would be unlikely to support any actions that would delay their project.
- In the case of an NCSD-owned facility, construction of pipelines across dunes to the ocean may be prevented by the numerous resource agencies that have an interest in preserving the biological resources there, especially if the proposed pipeline crosses agency-owned land.



Regulatory

- District must obtain approval of the Coastal Commission and the State Lands Commission for construction of intake and discharge facilities.
- Environmental review under CEQA must be initiated and/or completed by way of an EIR.
- The desalination treatment must be piloted to assist in the design of the facilities and demonstrate compliance with regulatory standards. Typically, long-term pilots are proposed for desalination projects - up to 1 year long - to ensure the pretreatment proposed works under all conditions.
- The construction of a treatment system, pipelines (including multiple stream crossings), and pumping facilities will require permits from local, state, and federal agencies.
- The desalted water would also require filtration and disinfection to meet federal and state surface water treatment regulations.
- Under the Nipomo Refinery option, chemicals added to the coolant water must be demonstrated to be nontoxic to humans to get DHS approval to use as a domestic source. Pilot testing would need to demonstrate that these chemicals are removed via the treatment process.

Legal

If the District decides to partner with either SSLOCSD or the Nipomo Refinery owner, then NCSD must enter into an agreement with either entity to secure deliveries from the new facility.

Cost

The estimated annual cost, including debt service on capital costs and O&M of the three alternatives, at the two pumping rates, is summarized below.

**Table 5-4 Probable Costs per acre-foot for each Desalination Alternative**

<b>Delivery Rate</b>	<b>a. Partner with Nipomo Refinery</b>	<b>b. NCSD Owned Facility</b>	<b>c. Partner with SSLOCSD with Added NCSD Pipeline</b>
3,000 afy	\$2,500/af	\$2,900/af	\$2,600/af
6,300 afy	\$2,200/af	\$2,400/af	\$2,300/af

# 6.0 Brackish Agricultural Drainage from Oso Flaco Watershed

## Introduction

This section considers the constraints associated with treating shallow ground water or agricultural runoff from Oso Flaco Lake and delivering the treated water to the Nipomo Community Services District (NCSD) distribution system. This alternative may include returning a portion of the treated flow to the watershed. A schematic map of the Project is shown in Figure 6-1.

## Setting

The Oso Flaco Creek Watershed covers approximately 10,370 acres. It is located north of the Santa Maria Estuary in the western portion of the Santa Maria Valley in San Luis Obispo County, California. Land use in the Oso Flaco Watershed is primarily irrigated vegetable row crops. Oso Flaco Creek has become degraded and functions primarily as a drainage channel to receive irrigation tail-water run-off.

The western terminus for the watershed is Oso Flaco Lake, owned by California State Parks. Oso Flaco Creek flows out of the lake and meanders ¼ mile to the Pacific Ocean through active sand dunes. Oso Flaco Lake is the largest of four small freshwater lakes located in the Guadalupe Nipomo Dunes Complex. The freshwater lake occupies a surface area of 82 acres and is classified by the U.S. Fish and Wildlife Service as palustrine emergent wetlands, a valuable habitat for wildlife, and subsequently a resource for many recreational and educational activities. (CRCD, 2004)

## Recent Studies

Water quality and associated biological resources in Oso Flaco Lake and its watershed have been recently studied. Pertinent reports include:

- Cachuma Resource Conservation District and the Dunes Center. *Draft Nitrate and Sediment Assessment, Oso Flaco Watershed, San Luis Obispo County, California, August 2004*. Report prepared for California Regional Water Quality Control Board, Central Coast Region.
- Central Coast Ambient Monitoring Program (CCAMP). *312 Santa Maria River Hydrologic Unit Draft Report for Sampling Year 2000*



## Supply

Average rainfall in the watershed is approximately 12 inches per year, occurring primarily between November and April. Storm runoff to Oso Flaco Lake has been estimated to average 1,512 acre-feet per year (AFY) (Lockhart, pers. comm..)

Older wells in the watershed are pumping from depths of 50 to 150 feet. Wells currently being drilled are drawing from 200 to 400 feet of depth. There is also a perched water table west of Highway 1. Oso Flaco and Little Oso Flaco Lakes are surface water bodies hydraulically connected to perched groundwater. (DWR, 2002) Sea water intrusion is apparently not occurring in this watershed, due to the steep gradient of fresh groundwater coming down the valley. (CRCD, 2004)

Oso Flaco Lake and Little Oso Flaco Lake are usually at maximum pool due to the steady flow of agricultural runoff. It has been estimated that 6,371 acres in the watershed are irrigated, primarily with pumped groundwater, and that 17,564 af/yr of water are applied, resulting in 968 AFY of agricultural runoff. Efforts are currently underway to improve irrigation efficiency to both reduce the quantity of water applied and the volume of agricultural runoff. It has been estimated that if 100% of the irrigated area were to adopt sprinkler/drip systems, the annual runoff volume would decrease to 440 AFY. (CRCD, 2004)

According to the estimates noted above, the total amount of water flowing to Oso Flaco Lake is approximately 1,120 acre-feet per year. It appears reasonable to conclude that extracting either 3,000 AFY or 6,300 AFY from the lake or hydraulically-connected shallow aquifer would significantly lower the existing level of the lake. It is reasonable to assume that such extractions would be opposed by the various regulatory agencies that have jurisdiction, and that this may represent a "Fatal Flaw" with this alternative

## Quality and Restoration Efforts

The Central Coast Ambient Monitoring Program (CCAMP) is conducted by the Central Coast Regional Water Quality Control Board's to provide a screening level assessment of water quality, based on a variety of chemical, physical and biological indicators. CCAMP monitoring in the Oso Flaco Creek watershed between 2000 and 2002 included conventional water quality, and sediment chemistry and toxicity. California Department of Fish and Game's Toxic Substances Monitoring Program also collected resident fish at Oso Flaco Lake in August 2001.

CCAMP collected data at three locations in the Oso Flaco Creek watershed, and determined that the 3 sites monitored did not support the beneficial uses of contact recreation, municipal water supply, aquatic

life, fish consumption, agricultural use and non-contact recreation. These CCAMP assessments are summarized in Table 6-1. Additional CCAMP data is summarized in Appendix B.

**Table 6-1 CCAMP Findings and Beneficial Uses in the Oso Flaco Creek watershed.**

Monitoring site	Unsafe to Swim?	Unsafe to drink?	Are aquatic life uses impaired?	Unsafe to eat fish?	Are agriculture uses impaired?	Are non-contact recreation activities impaired?
Little Oso Flaco Creek at railroad crossing	Yes	Yes	S	-	Yes	Yes
Oso Flaco Creek at Oso Flaco Lake Road	Yes	Yes	Yes	-	Yes	Yes
Oso Flaco Lake at culvert	Yes	Yes	S	Yes	Yes	Yes

(Excerpted from Table 5.1.1b, CCAMP, 2002)

Yes - evidence that a problem exists, No - no evidence that a problem exists, S – some evidence that a problem may exist.

The inability to support these beneficial uses was based on:

- elevated fecal coliform concentrations,
- observed pH > 8.4,
- elevated nitrate concentrations,
- elevated un-ionized ammonia concentrations,
- low dissolved oxygen levels,
- toxicity,
- pesticide residue in fish tissue,
- chlorophyll concentrations,
- algal cover,
- turbidity, and
- measures of biotic integrity.

Oso Flaco Creek and Oso Flaco Lake were listed on the CWA section 303(d) list of impaired waterbodies (CCRWQCB 2002). Oso Flaco Creek was listed for impairment due to fecal coliform and nitrate, and Oso Flaco Lake was listed for impairment due to nitrate.

Oso Flaco Lake was the only water body in the 2000 assessment area specifically identified in the Basin Plan as not supporting the Municipal Supply beneficial use.

The Regional Board is now in the process of developing total maximum daily loads (TMDLs) for nitrates, fecal coliform, and pesticides. Once approved, these TMDLs will establish 1) an allowable amount of a pollutant to each waterbody, 2) proportional responsibility for controlling the pollutant, 3) numeric indicators of water quality, and 4) implementation to achieve the allowable amount of pollutant loading.

Local growers are working with the Cachuma Resource Conservation District to develop and implement practices to reduce agricultural runoff, nitrate loadings, and sediment loads, and to improve habitat.

## **Reliability**

As part of this alternatives study, Oso Flaco surface water and perched water are being compared to other potential sources. For purposes of comparison, each alternative is evaluated under two design flows: 3,000 acre-feet per year (AFY) and 6,300 AFY.

The surface water in Oso Flaco Lake and its associated perched aquifer receive water from precipitation, agricultural underflow, and agricultural runoff. As noted above, efforts are underway to decrease the amount of applied irrigation and agricultural runoff. As also noted above, a more detailed hydrogeological study of the lake, watershed, and perched aquifer would be needed in order to form an opinion of the reliability of this potential source.

## **Required Facilities**

Water quality in Oso Flaco Lake, Oso Flaco Creek, or shallow groundwater associated with either of these sources dictate that a treatment facility must be built to reduce or remove the following constituents:

- Microorganisms
- Nitrate
- Dissolved solids
- Turbidity
- Sulfate

In addition, elevated levels of the following constituents were found in fish tissue or sediment, or through toxicity identification analyses, and therefore may result in additional treatment requirements:

- Chlorpyrifos
- DDT

- Endrin
- Toxaphene

DHS requirements that this “extremely impaired source” be treated with the “best available technology” limit the options for treatment, as shown below:

**Table 6-2 Probable Treatment requirements for Oso Flaco Water Source**

Treatment Technology	Coagulation, Filtration & Disinfection <sup>1</sup>	Ion Exchange	Reverse Osmosis	Electrodialysis	Granulated Activated Carbon	Packed Tower Aeration
Microorganisms	x		x			
Nitrate		BAT	BAT	BAT		
Dissolved solids			x			
Turbidity	x		x			
Sulfate			x			
Chlorpyrifos						
DDT						
Endrin					BAT	
Toxaphene					BAT	BAT

BAT = best available technology per USEPA, x = effective treatment, probable requirement (1) or approved alternative filtration technology

Treatment Option:

One treatment option was investigated as part of this constraints analysis:

1. coagulation, filtration and disinfection, followed by
2. reverse osmosis, and
3. granular activated carbon.

Project Components:

Based on this constraints analysis, the following facilities will be required to obtain water from the Oso Flaco Lake perched aquifer, treat it, dispose of the waste, and transport the treated water to the NCSD distribution system:

- Well Site (purchase land);
- Treatment Plant;

- Subdivide and purchase a site for the wells and the treatment plant;
- Improvements to electrical grid for required power;
- 2 miles of 18-inch effluent pipeline;
- Ocean outfall; and
- 6 miles of 18-inch pipeline to connect to NCS D distribution system at Eureka well site.

## Implementation Schedule

Given the time needed for interagency cooperation, extensive environmental review, design, construction, and startup, it is expected that implementation of any of these alternatives would take between 7 and 10 years. Steps would be similar to the desalination options in the previous section.

## Constraints

### Institutional

Institutional constraints for the proposed project are identified as follows:

The vast majority of Oso Flaco and Little Oso Flaco Lakes is on land owned by California State Parks. It is expected that State Parks would only support the project if it could be demonstrated to be environmentally beneficial and compatible with current and planned uses of the parkland.

### Legal

Oso Flaco drainage is considered a component of the Santa Maria Valley Groundwater Basin, and use of this supply would require approval by all signatory parties to the litigation and subsequent management agreements. This water may be available for development if it drains through Oso Flaco Lake to the ocean and does not recharge the NMMA subbasin. No data or historical documents reviewed define or describe the hydro-geological connectivity of the surface or perched groundwater to the principal production aquifer underlying the NMMA. Additional field investigations would be required to determine the character of hydrological connectivity of the Oso Flaco watershed to the NMMA.

### Regulatory

Department of Health Services: For municipal drinking water uses, the California Department of Health Services (DHS) would probably consider surface water or shallow groundwater from the Oso Flaco watershed an “extremely impaired source” (IES). It would be classified an IES because nitrate and nitrogen concentrations exceed 3 times their MCLs, and because the waters contain a mixture of contaminants of health concern.



The use of this “extremely impaired source” would probably not be approved unless the additional health risk, relative to the use of other available drinking water sources, are known, minimized, and considered acceptable by DHS. DHS policy dictates that an extremely impaired source should not be considered for direct human consumption where alternatives are available. In addition, DHS policy requires that drinking water quality and public health shall be given greater consideration than costs or cost savings when evaluating alternative drinking water sources or treatment processes.

In other words: DHS would approve of this alternative only if it was the best alternative possible, regardless of price.

Before an extremely impaired source can be used for municipal supply the following process must be implemented:

- Determine the extent to which the aquifer or surface water is vulnerable to contaminating activities. (This step has been partially completed through monitoring associated with the CCAMP program.)
- Full characterization of raw water quality. (Additional monitoring would be required.)
- There must be a program in place to control the level of contamination. (At a minimum, best management practices for waste handling and waste reduction would be required.)
- The treatment process must be commensurate with the degree of risk associated with the contaminants present. (As a minimum, treatment would require use of the *best available treatment technology* defined by the EPA. See discussion under Required Facilities.)

California Environmental Quality Act (CEQA). Environmental review under CEQA must be completed for the project. Given the scope of the project, and the potential to impact numerous sensitive resources, it is expected that a full Environmental Impact report (EIR) would be required.

Other Resource Agencies. The construction of a treatment system, ocean outfall, pipelines (including multiple stream crossings), and pumping facilities will require permits from numerous local, state, and federal agencies.

### Cost

The estimated annual costs, including debt service on capital costs and O&M, assuming the two delivery rates investigated can be achieved, are \$2,700/af with a 3,000 afy facility, and \$2,300/af with a 6,300 afy facility.

The cost of this project may be partially offset if suitable grants or loans can be arranged. Examples of funding programs that may be applicable include:

- California Department of Water Resources (DWR) Local Groundwater Assistance Program: Local public agencies with authority to manage groundwater resources can apply for up to

\$250,000 for projects providing groundwater data collection, modeling, monitoring and management studies; monitoring programs and installation of equipment; basin management; and development of information systems

- DWR's Water Desalination Program: Local agencies can apply for grants to support development of local water supplies through brackish water and sea water desalination. Up to \$25 million is available statewide during the current funding cycle.
- DWR's Agriculture & Urban Water Use Efficiency Program: Local agencies, public agencies, incorporated mutual water companies, and tribes can apply for grants to support agricultural and urban water use efficiency implementation projects or studies that carry out the goals of the California Bay Delta Program's Water Use Efficiency Program. Total Program Funds: \$120 million, pending California Department of Finance exemption. Up to \$35 million is available statewide during the 2006/2007 funding cycle.

### Capacity

The capacity of this alternative is dependent on the amount of water available from the lake and associated shallow aquifer. Any water removed from this watershed would likely lower water levels in the lakes, with the exception of storm waters that otherwise discharge to the ocean. However, in order to utilize storm water, a retention facility would be required to capture short-term storm events and make these waters available over the following months. If withdrawals are limited to agricultural return flows, production would be less than 968 AFY, possibly decreasing to less than 440 AFY if irrigation conservation measures are universally adopted in the watershed.

# 7.0 Nacimiento Water Project Extension

## Introduction

The NWP is a transmission facility that will convey raw water from Lake Nacimiento to communities in San Luis Obispo County. The San Luis Obispo County Flood Control & Water Conservation District (SLOCFCWCD) is managing the design and construction of this facility. The initial contracted participants are the City of El Paso de Robles, Atascadero Mutual Water Company, Templeton Community Services District, Cayucos County Service Area (CSA 10A), and the City of San Luis Obispo.

The NWP consists of 45 miles of transmission pipeline ranging in size from 30 to 12 inches in diameter; storage reservoirs; and booster pump stations. The pipeline ends at the City of San Luis Obispo Water Treatment Plant (SLO WTP) turnout.

This section considers the constraints associated with extending the Nacimiento Water Project (NWP) pipeline from the City of SLO Turnout to the Nipomo Community Services District (NCSO) distribution system. A schematic map of the Project is shown in Figure 7-1.

## Previous Studies

The following list summarizes the studies and documents referenced in this evaluation:

- Nacimiento Reservoir: Reliability As a Water Source for San Luis Obispo County (Boyle Engineering, October 2002)
- Nacimiento Water Project: Technical Memorandum (TM) 8 Water Quality Investigations for San Luis Obispo County Flood Control & Water Conservation District (SLOCFCWCD) (Black & Veatch, January 2006)
- Supplemental Water Supply Study: Nacimiento Pipeline Extension for City of Arroyo Grande, City of Grover Beach, and Oceano CSD (Wallace Group, January 2006)
- Nacimiento Water Project: Preliminary Design Report (PDR) for SLOCFCWCD (Black & Veatch, in Association with Boyle Engineering, July 2006 FINAL)
- AIWRP Water Supply Evaluation: Nacimiento Treatment Evaluation for City of El Paso de Robles (Boyle Engineering, September 2006)
- Agendas from NWP Commission and Board of Supervisors of the SLOCFCWCD

DWG: W:\Nipomo\_CSD (19996)\19996.32 (Alternative Water Supply)\CAD\Design\Revised Figures and Plots\Figure 7-1\_Nacimiento Extension.dwg  
DATE: Jun 11, 2007 8:49am  
USER: cramer  
PLOTTER: COWI PLOTLINE  
PLOTSCALE: Large Map: 1/8"=1'

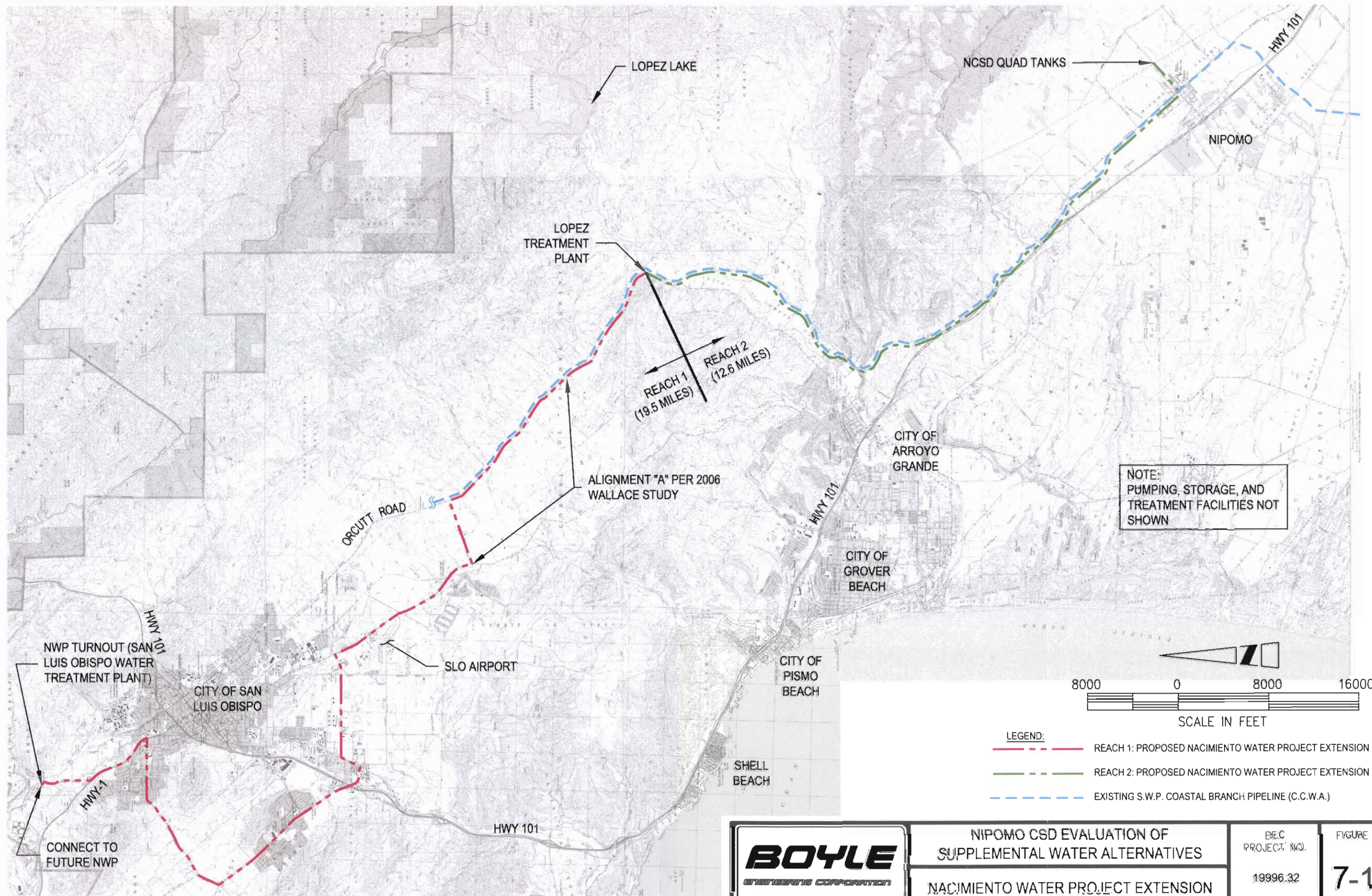

## Supply

The SLOCFCWCD has an annual entitlement of 17,500 acre-feet (AF) within Lake Nacimiento through a 1959 Agreement with Monterey County Water Resources Agency (MCWRA) and is owner of the NWP.

The NWP is designed to convey 15,750 acre-feet per year (AFY) with the remainder of the entitlement set aside for lakeside use. The total delivered entitlement currently under contract is 9,655 AFY. The “Reserved Capacity” (or unsubscribed entitlement) is 6,095 AFY.

Initially the SLOCFCWCD intended to deliver the full Reserved Capacity to the end of the project. In an effort to reduce the construction cost of the NWP, the SLOCFCWCD reduced pipeline size and capacity between Santa Margarita and the City of San Luis Obispo’s Turnout. As indicated on the Design Plans for the NWP, the last reach ending at the SLOWTP will be 12-inches in diameter with a current deliverable Reserved Capacity of 2,148 AFY. However, Mr. Hollenbeck indicated the last reach of the NWP could be upgraded to provide up to 3,000 AFY if an interested agency paid for design revisions and were able to sign an agreement with SLO County.

## Quality

The NWP will convey raw surface water. Participants will need to treat the water or utilize aquifer storage and recovery. The City of El Paso de Robles plans to construct a surface water treatment plant for NWP water. As discussed in the Water Source Evaluation for the City of Paso Robles (Boyle 2006), the City will treat the raw water, blend it with groundwater, and pump it directly into their distribution system. The City of San Luis Obispo plans to treat its NWP water at its existing water treatment plant located on Stenner Creek Road. TCSD and AMWC plan to use their NWP deliveries for aquifer recharge via spreading ponds.

Nacimiento Water Project PDR identified the following water quality issues that could potentially affect NWP participants:

- Algae;
- Iron and manganese;
- PH, alkalinity, and hardness (corrosion potential);
- Odor;
- Turbidity and color; and
- Disinfection byproduct formation

In order to utilize this water supply, the NCS D will need to filter and disinfect the raw surface water, or develop an aquifer storage and recovery (ASR) system. In addition, the District must ensure compliance with the drinking water standards for disinfection by products (DBPs), ensure maintenance of a disinfectant residual, and address potential corrosion impacts due to the water.

## **Reliability**

The current NWP Delivery Entitlement Contracts provide the initial participants with an annual allocation in Acre-feet (AF) of NWP water, including specified maximum instantaneous flow rates in cubic feet per second (cfs) and maximum allocations for any given month of service. Additionally, the maximum period of delivery for any participant is 11 months in order to allow for routine maintenance of the NWP.

It is understood the City of San Luis Obispo's allocation of 3,380 AFY of NWP water will be delivered at a constant rate for 11 months per year. Similarly, it is understood the current deliverable Reserved Capacity at the SLOWTP pipeline terminus could be delivered at a constant rate for the same 11-month duration. However, as discussed previously in this report, only 2148 AFY will be available for the District.

As indicated in the NWP Preliminary Design Report, backup systems for critical project components (e.g. backup pumps, backup communications) are incorporated into the NWP design to enhance system reliability.

## **Required Facilities**

Two options were evaluated in this Constraints Analysis:

- Participation in a regional project to extend the NWP pipeline to other South County purveyors; and
- Transmission of Nacimiento Water to Nipomo CSD, with no additional partners or South County participants.

### Regional NWP Participation

A NWP extension to the NCS D service area will likely require participation from other agencies to help offset the expected high capital and NWP "buy-in" costs. The Cities of Arroyo Grande and Grover Beach and Oceano Community Services District jointly evaluated the feasibility of extending the NWP from its terminus at the SLOWTP to the Lopez Water Treatment Plant for distribution as supplemental water to South County Purveyors (2006 Supplemental Water Supply Study, Wallace Group). The 2006 study conducted by the purveyors considered two alternative alignments for the pipeline extension.

Both alternatives utilized the NWP EIR alignment from the SLOWTP to the SLO Airport area<sup>6</sup> (approximately 9.5 miles). Descriptions of both alternative alignments evaluated by Wallace Group are as follows:

- Alignment A: From SLOWTP to Lopez WTP along Orcutt Road, parallel to the existing State Water Pipeline (17.5 miles total)
- Alignment B: From SLOWTP to Lopez WTP along Orcutt Road, utilizing the planned Plains Oilfield pipeline from Price Canyon, along Highway 227 (18.1 miles total)

Based on a review of this study, the primary assumptions used in Wallace Group's analysis were as follows:

- NWP reserve capacity available for new participants in southern SLO County is 2,100 AFY
- NWP pipe size at SLOWTP is 20-inches inner diameter (I.D.)
- NWP delivered Hydraulic Grade Line (HGL) at SLOWTP turnout is 1295 feet
- Ground Elevation at SLOWTP is 400 feet; Nominal water surface elevation at Lopez Reservoir is 383 feet
- Raw water conveyed by NWP extension will be treated (filtered and disinfected) at the Lopez WTP and conveyed to South County area water purveyors via the Lopez distribution system

Since NWP design had not been completed at the time of the 2006 Wallace Study, the study addressed a range of hydraulic conditions at SLOWTP. The study concluded a 12-inch diameter pipeline would be sufficient to convey approximately 2300 AFY of water along Alignment A given a minimum calculated HGL of approximately 1260-ft at the SLOWTP. A 16-inch diameter pipeline would be required if the available HGL was reduced to 575-ft at the SLOWTP. A booster station would be required for any further reductions in NWP delivered HGL at the SLOWTP turnout. To accommodate this additional flow, the Lopez WTP would need to be expanded and the Lopez Distribution system may need to be upgraded.

Raw water allotted for NCS D could be treated at the Lopez WTP, or conveyed further south to the NCS D service area for treatment and distribution. As shown on Figure 7-1, it may be possible to align the remainder of the pipeline extension from the Lopez WTP to NCS D (approximately 12 miles) parallel to the existing Central Coast Water Authority (CCWA) pipeline and possibly within its easement.

It is anticipated a connection to NCS D's distribution system can be made near the vicinity of Tefft St. and Thompson Rd.; however, the pipeline could be extended to the Quad Tank Site near Foothill Rd. and Tefft St. If treatment is not provided at Lopez Lake, a water treatment facility will be required to filter and disinfect the raw water prior to introduction into the municipal water supply.

---

<sup>6</sup> This sub-alternative was previously evaluated as part of the December 2003 Final EIR for the NWP

### Sole Ownership of Nacimiento WP Extension from SLO WTP to NCS D Service Area

If this option is pursued, the project alignments and facilities discussed above (except treatment at the Lopez WTP) would still be appropriate. However, the District would bear the full cost for all facilities.

#### Project Components:

Based on this constraints analysis, the following facilities will be required to extend the NWP pipeline from the SLO WTP to the NCS D distribution system. It is assumed project alignments and components would be similar for either alternative mentioned above:

- Reach 1 (SLOWTP to Lopez WTP): Extension of approximately 92,400 linear feet (17.5 miles) of pipe (Alignment A as identified in 2006 Wallace Study);
- Reach 2 (Lopez WTP to NCS D);
  - Pipeline extension: 65,000 linear feet (12.3 miles) of pipe;
  - Connection to existing municipal water system w/possible required upgrades
- Booster pump station(s) and Storage facilities at SLO WTP Turnout, Lopez WTP, and/or Nipomo CSD tie-in; and
- Water treatment plant to filter and disinfect raw NWP water

### **Implementation Schedule**

As of the date this section was written (January 2007), the NWP was nearing 100% design completion and the final bid packages were being prepared for submittal to SLOCFCWCD. The plans and specifications were bid in May 2007 for award sometime later in the year. Additionally, as currently designed, the final reach of the NWP has a deliverable capacity of approximately 2,148 AFY for new South County participants.

As these dates indicate, the project window is rapidly closing for any additional participants. During our January 25, 2007, meeting with Mr. Hollenbeck, he indicated any interested South County participants would need to quickly commit and be able to enter an Agreement with San Luis Obispo County for an entitlement to available NWP water. He also indicated the interested agencies would need to satisfy the CEQA process prior to the County entering an Agreement with them. It is our understanding a Supplemental EIR would need to be initiated and/or Draft completed prior to said Agreement being executed.

With regards to project implementation schedule, the Wallace Study estimated a project timeline of approximately 5 years for Reach 1, from the beginning of agency agreements to completion of construction.



It is estimated approximately five (5) to seven (7) years will be required to fully implement Reach 1 and 2 of this project.

## **Constraints**

### Institutional

Institutional constraints for the proposed project are identified as follows:

- NCS D must decide if it wants to further pursue the feasibility of extending the NWP.
- To share costs, the NCS D must quickly mobilize and secure sufficient participation from interested South County communities.
- NCS D must determine its minimum acceptable water volume entitlement for negotiating with SLOCFCWCD and tentative South County Participants. NCS D will not be able to secure the full 3,000 AFY from the NWP extension.
- NCS D must notify SLOCFCWCD of its intentions and receive approval from the existing project participants. They would be unlikely to support any actions that would delay their project, so it is unlikely they would allow the District to contribute toward design and construction of a larger capacity pipeline between Cuesta Tunnel and San Luis Obispo.

### Legal

Legal constraints are summarized as follows:

- NCS D and interested South County participants must enter into agreements with SLOCFCWCD to secure NWP deliveries. As a condition for executing this agreement, it is understood environmental review under CEQA must be initiated and/or completed along the pipeline extension corridor by way of a Supplemental EIR.
- As identified in the 2006 Wallace Study, NWP deliveries to South County participants will likely require alteration of the Zone 3 Entitlement Contracts. The existing Lopez Distribution system downstream of the Lopez WTP would probably be utilized for delivery of NWP water. This may delay participation by NCS D's potential project partners.

### Regulatory

As indicated above, environmental review under CEQA must be initiated and/or completed along the pipeline extension corridor by way of a Supplemental EIR prior to SLOCFCWCD entering into an agreement with any additional prospective participants.

The construction of a treatment system, storage tanks, pipelines (including multiple stream crossings), and pumping facilities will require permits from local, state, and federal agencies.

The water would also require filtration and disinfection to meet federal and state surface water treatment regulations.

### Cost

From the December 14, 2006, Nacimiento Project Commission Agenda Item V.a (Total Project Cost Update-90% Progress Point), the total capital cost for the City of San Luis Obispo is approximately \$80.4M (\$23,800 per AFY capacity). The estimated annual cost, including annual debt and O&M, is approximately \$6.4M to \$7.1M. This results in an overall cost of approximately \$1900-\$2100 per AF, for delivery of 2100 AFY (maximum reserve capacity in pipeline) raw water to the SLO City Turnout.

In addition, the project would require storage, pumping, water treatment, and transmission facilities between the SLO City Turnout and the NCS D distribution system. The project cost for the transmission main (approximately 30 miles) would be over \$1 million per mile, assuming 12-in PVC pipe was installed, for a total of \$30M. At 6% interest, over a 20-year payback period, the pipeline alone would cost over \$1100 per AF for 2100 AFY delivery.

Therefore, the cost of delivery at the SLO City turnout and transmission to the NCS D system would cost \$3000-\$3200 per AF. With supporting facilities (storage, pumping, and filtration), a planning-level cost of over \$4000 per AF may be expected.

WIP would be considerably less expensive at approximately \$2100 per AF (including debt service at 6% over 20 years, operations & maintenance, and purchase price from Santa Maria per the MOU). This is based on the \$26M budget described in the draft WIP Preliminary Engineering Memorandum (Boyle, 2006).

### Capacity

In considering the desired water quantity for NCS D of 3,000 AFY, the desired water quantity in the 2006 Supplemental Water Study for 2,300 AFY, and the Reserved Capacity of 2,148 AFY at the NWP terminus, there is currently not enough deliverable capacity at the end of the NWP pipeline to satisfy all needs. However, as described above, Mr. Hollenbeck indicated it might be possible to marginally increase NWP deliverable capacity to new South County participants. It is doubtful the NWP deliverable capacity can be increased to satisfy the total desired water quantity of 5,300 AFY. If the NCS D pursues this alternative water supply, all potential South County participants (including the NCS D) will likely need to compromise and accept smaller water allocations as the available water is proportioned along the various new participants. If NCS D pursues the NWP extension without any additional partners, only 2,148 AFY (of desired 3000 AFY) would be available.

# 8.0 Recharge of Groundwater with Recycled Water from Southland WWTF

## Introduction

### Background

The Nipomo Community Services District (NCSD) owns and operates the Southland Wastewater Treatment Facility (WWTF), located just west of Highway 101 in the southern portion of San Luis Obispo County, California. The WWTF provides secondary treatment for a mixture of domestic and industrial wastewater from part of the Nipomo community under Waste Discharge Requirements (WDR) Order No. 95-75. Existing facility components include four aeration ponds, two sludge-drying beds, and eight infiltration basins. The WWTF has a permitted capacity of 900,000 gallons per day based on the maximum monthly demand.

This analysis considers constraints associated with developing a groundwater recharge program within the Nipomo Mesa Management Area (NMMA) involving recharge of the groundwater basin with recycled water from Southland WWTF.

### Objective

Groundwater recharge is proposed to provide a means to manage and help stabilize the groundwater basin within the subject area, and is not a true supplemental water supply alternative. The objectives of this alternative include:

- Stabilize and elevate existing groundwater pumping depressions; and
- Prolong useful life of existing NCSD wells.

## Previous Studies/Documents

The following list summarizes the studies and documents referenced for this evaluation:

- Technical Memorandum, Yield of Aquifer Storage and Recovery (SAIC, June 2007)
- Southland Wastewater Treatment Facility Master Plan (Boyle Engineering, Draft February 2007)
- Task 25 – Screening Evaluation of Potential Recharge Locations of Treated Effluent (Garing Taylor & Associates, January 16, 2007)
- Groundwater in Storage Underneath the Nipomo Mesa Management Area As of April 2006, Draft Technical Memorandum (SAIC, October 11, 2006)
- Urban Water Management Plan 2005 Update (SAIC, January 2006)
- Phase V Stipulation of the Santa Maria Groundwater Litigation (June 30, 2005)
- Nipomo Mesa Groundwater Resource Capacity Study (SS Papadopulos, March 2004)
- Water Resources of the Arroyo Grande - Nipomo Mesa Area (DWR Southern District, 2002)
- Final Report: Evaluation of Water Supply Alternatives (Kennedy/Jenks, October 2001)

- Evaluation of Alternative Water Supplies (Bookman-Edmonston, July 1994)

## Supply

### No Increase in “Supply”:

The proposed groundwater recharge alternative is intended to function as a groundwater management program within the subject area of the NMMA. No increase in supply to the District would result because Southland WWTP discharge is assumed to be included in the groundwater budget that has been presented during litigation involving the Santa Maria and Nipomo aquifers. (i.e., WWTP groundwater recharge is already considered as “return flows” to the NMMA.)

As no new supplemental water will be imported from outside the NMMA, there will be no effect on the overall water balance within the NMMA. However, there may be some benefit to the specific study area, previously described as the depressed groundwater basin within the NMMA bounded by the Oceano and Santa Maria River Faults.

### Quantity Available from Southland WWTF:

Average annual flow rates to the Southland WWTP are currently 0.59 MGD, equivalent to approximately 662 acre-feet per year (AFY). These flows are projected to increase to 1,460 AFY (1.3 MGD) in the year 2030. For the purpose of this analysis, it is assumed effluent flows, and therefore flows discharged to the infiltration basins, are equivalent to the existing and projected influent flows.

### Hydrogeology:

Review of available data tends to indicate the presence of a low-permeability layer overlying the production aquifer in the western portion of the District. This evidence includes observations of three artesian wells located near the ocean (11N36W12C), anecdotal evidence that Santa Maria River surface flows beyond the Bonita School Road Crossing do not contribute to the underlying principal production aquifer, the existence of and morphology of Black Lake Canyon, and driller reports from District production wells. If additional data and subsequent investigations confirm the presence and extent of this confining layer, then suitable locations for percolation ponds would be limited to an area bounded by the confining layer to the west, Black Lake Canyon to the north, the bluffs to the south, and the Santa Maria River Fault to the east (SAIC, 2007). See Figure 8-1.

DWG: W:\Nipomo CSD (19996)\19996.02 (Alternative Water Supply)\CAD\Design\Revised Figures and Plates\Figure 8-1\_Groundwater Recharge.dwg  
 DATE: Jun 11, 2007 8:50am  
 XREFS: BASE MAP  
 USER: croner  
 IMAGES: SCAN4951\_000.tif  
 Parcels

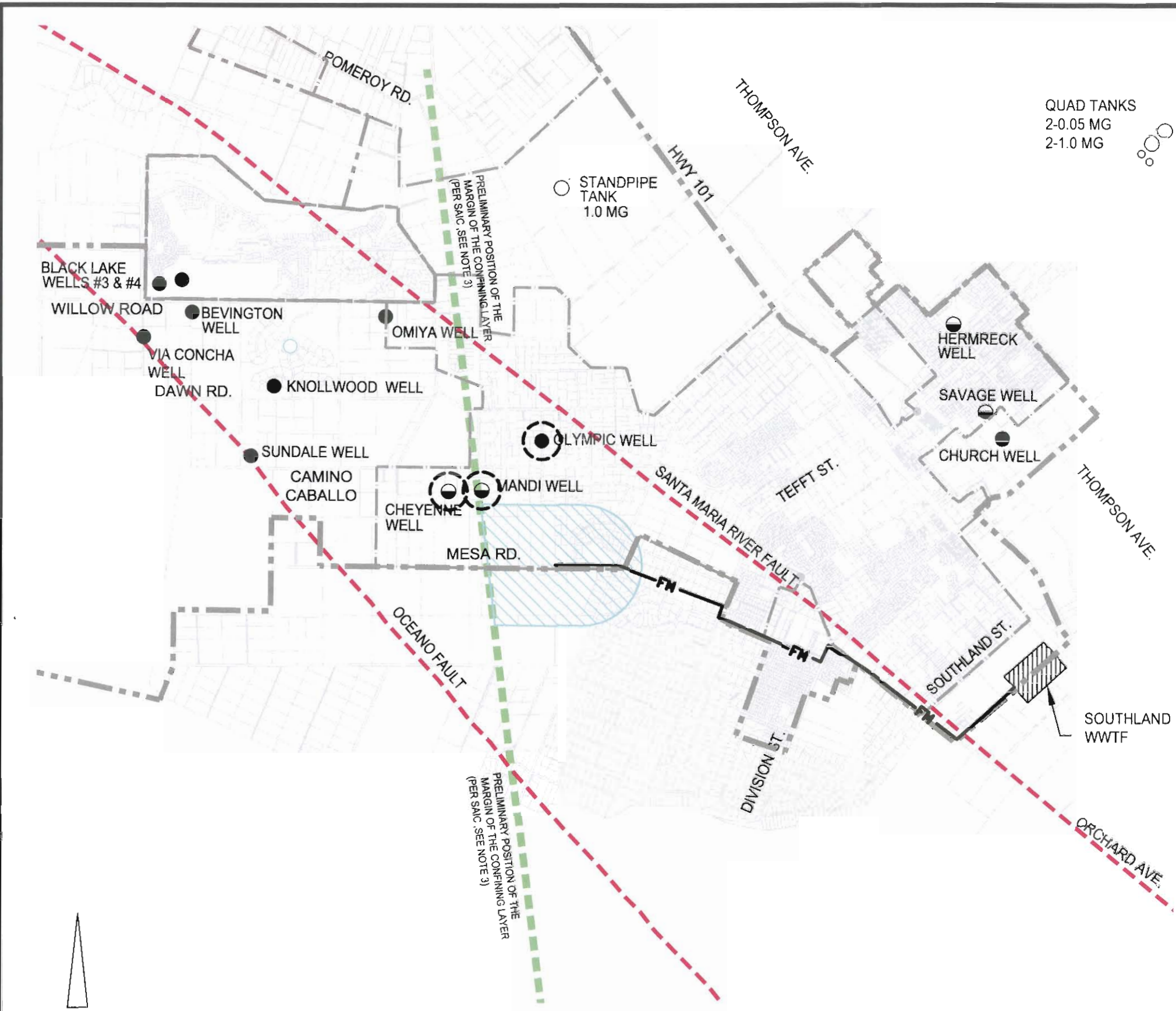

**NOTES:**

1. POTENTIAL GROUNDWATER RECHARGE LOCATIONS AND PIPELINE ALIGNMENTS ARE DERIVED FROM THE 2007 GTA EVALUATION OF POTENTIAL RECHARGE LOCATIONS.
2. PER SECTION 60320.010 OF CDHS GROUNDWATER RECHARGE REUSE DRAFT REGULATIONS (JAN. 4, 2007), RECYCLED WATER SHALL NOT BE EXTRACTED WITHIN 500 FEET OF ANY GRRP SURFACE SPREADING AREA.
3. POSSIBLE LOCATION OF EASTERN MARGIN OF POSSIBLE CONFINING LAYER.

**LEGEND**

- POTENTIAL GROUNDWATER RECHARGE LOCATION (SEE NOTE 1)
- NIPOMO CSD WELLS
- NIPOMO CSD WELLS (STANDBY)
- NIPOMO CSD TANKS
- FUTURE WATER SYSTEM SERVICE AREA BOUNDARY
- EXISTING WATER SYSTEM SERVICE AREA BOUNDARY
- APPROXIMATE FAULT LINE
- RECYCLED WATER FORCE MAIN

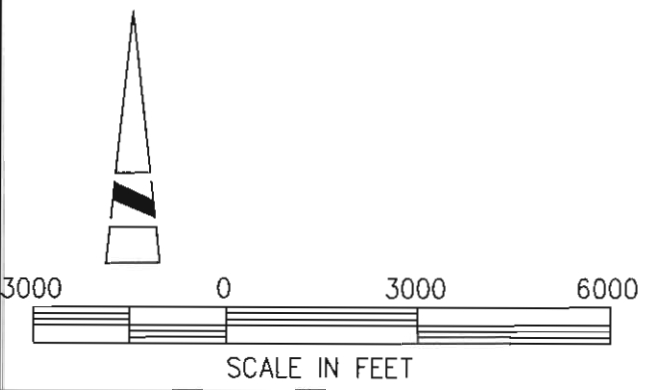

**NIPOMO CSD EVALUATION OF  
 SUPPLEMENTAL WATER ALTERNATIVES**  
**GROUNDWATER RECHARGE OF RECYCLED  
 WATER FROM SOUTHLAND WWTF**

BEC  
 PROJECT NO.  
 19996.32

FIGURE  
**8-1**

## Quality

Implementation of this recharge alternative will need to consider and mitigate impacts to groundwater quality. Constituents of concern include salts and nitrogen.

Salt accumulation in the groundwater basin resulting from high dissolved solids in recharged effluent may pose a challenge for this alternative. Total Dissolved Solids (TDS) concentrations in the effluent vary between 980 and 1180 mg/l while TDS in NCSD drinking water is approximately 650 to 675 mg/l. Secondary Maximum Contaminant Levels for TDS are 500 mg/l.

Nitrogen in effluent is also a concern. Nitrate concentrations in District drinking water has averaged between 5.1 and 6.8 mg/l as nitrate during 2005 and 2006, while the Primary MCL for nitrate is 45 mg/l as nitrate, or 10 mg/l as nitrogen. Total Nitrogen in the effluent typically measures at 28-46 mg/l.

### Treatment Requirements for Recycled Water from Southland WWTF:

The 2007 Draft Groundwater Recharge Reuse Regulations prepared by CDHS indicate recycled water used for groundwater recharge reuse projects (GRRP) must meet the definition of filtered, disinfected tertiary wastewater. Additionally, the median and maximum total coliform limits are the same as for disinfected tertiary wastewater for unrestricted urban use. The Draft regulations also set forth guidelines for maximum percentage of recycled water and maximum contaminant levels (MCLs) as well as other physical parameters.

It is assumed the requirements and criteria in the draft regulations would be implemented in this reuse project. Because the Southland WWTF currently only provides secondary treatment, treatment plant improvements will be required.

## Reliability

Recycled water is considered a reliable water supply. However, its reliability as it pertains to groundwater recharge is contingent on the NCSD's ability to provide and maintain recycled water quality meeting the Draft Groundwater Recharge Reuse Regulations as well as taking additional necessary measures to mitigate salt accumulation in the groundwater basin.

The recharged groundwater will be extracted by existing or new NCSD wells. Therefore, the reliability of the return flows will be approximately the same as the existing groundwater supply. Therefore, its reliability may be hindered by drought conditions within the NMMA and any further development/expansion of the pumping depressions.

## Required Facilities

The Southland WWTF Master Plan (Boyle 2007) identified 2 methods for recharge: (1) direct injection with groundwater wells and (2) surface spreading and percolation. The Master Plan indicated the latter option may be preferred because it would allow natural filtration of the percolated wastewater, allowing further biological and filtration treatment. Direct injection is often energy intensive, requiring high capital costs due to the requirement for RO treatment, may present public perception concerns, and may require an additional level of treatment to assure the public that contamination is not a significant risk. For the purposes of this analysis, it is assumed recharge will occur by surface spreading and percolation.

In order to utilize its treated wastewater discharge for groundwater recharge, it is expected the NCSD will upgrade its treatment to provide "Tertiary Recycled Water". This level of treatment will require oxidation, coagulation, filtration and disinfection (Boyle, 2007). The District will also need to provide a potable water source for diluting the recycled water, as required by the Draft CDHS Regulations. In order to convey the recycled water to the recharge facilities/ponds, the NCSD will also need to construct pumping and transmission pipeline facilities.

NCSD selection of recharge sites will need to satisfy the following minimum criteria:

- (1) Soil conductivity must be such that percolation capacity is suitable for desired recharge rate
- (2) Percolation ponds should be located where recharge will increase available water in aquifer (see Hydrogeology discussion above)
- (3) Source of potable diluent water must be available
- (4) Extraction shall not be within 500 feet of recharge facility

Based on a preliminary screening of undeveloped properties within the areas noted (GTA, 2007) the general location of the proposed facilities were selected, and are shown in Figure 8-1. As noted above, additional geological investigations will be required in order to determine the feasibility of recharge with recycled water, and to evaluate the suitability of any particular site for infiltration.

### Project Components:

The following facilities will be required to implement this groundwater recharge alternative:

- Upgrades to Southland WWTF to provide disinfected tertiary recycled water, including filtration and disinfection;
- Transmission pipeline and/or connection(s) to existing potable water system to provide diluent water;
- Pumping and transmission pipeline facilities to convey recycled water to recharge facilities;
- Percolation ponds (15 acres would be sufficient to percolate 1,460 AFY, the flow rate projected for the Southland WWTP in 2030); and
- Upgrades to existing water pumping, treatment, and transmission facilities.

## Implementation Schedule

It is estimated approximately 2 to 4 years will be required to fully implement this project.

## Constraints

### Institutional

Institutional constraints for the proposed project are identified as follows:

- Public perception with the *use* of recycled water for groundwater recharge may be a problem.
- Public perception may be a problem with regards to *locating* a percolation basin or combination percolation/stormwater detention adjacent to or within a residential development.

### Legal

The Court would not consider the proposed groundwater recharge as newly “developed” or “salvaged” water because it is assumed to have been included in the groundwater budget presented during litigation, and thereby already counted as “return flows” to the NMMA.



## Regulatory – Water Resources

In order to utilize its wastewater discharge for a groundwater recharge reuse project, the NCSD will need to upgrade its treatment facility. NCSD will also need to revise the Waste Discharge Requirements for Southland WWTF to allow reuse of plant effluent for groundwater recharge.

NCSD should conform to the 1994 CDHS Groundwater Recharge Reuse Draft Regulations for its Groundwater recharge reuse project (GRRP). In doing so, NCSD will be required to prepare and submit an engineering report for approval to CDHS and the RWQCB containing a comprehensive investigation and evaluation of the proposed GRRP and other required information and action plans. Following submission of this report, NCSD will be required to administer an industrial pretreatment and pollutant source control program. It is understood CDHS will conduct public hearings for the proposed GRRP prior to making recommendations to the RWQCB regarding permitting.

The construction of an expanded treatment system, pipelines, percolation basins, and pumping facilities will require permits from local and state agencies.

## Cost

The probable cost of improvements is approximately \$15 million and includes treatment, conveyance, and percolation facilities. These costs do not include land acquisition. Amortizing this cost over 20 years and including approximately \$30,000 to \$40,000 in annual operational costs brings the total annual cost to between \$1.4 million and \$1.5 million. This alternative recycles between 596 and 1,683 AFY of treated wastewater, but may not produce any “new” return flows. The cost per acre-foot of treated and percolated water is \$870 to \$2,320, depending on the flow rate, plus the cost of land acquisition, if any.

## Capacity

The implementation of this alternative will be constrained by the volume of water treated at Southland WWTP, currently equal to approximately 662 acre-feet per year (AFY), projected to increase to 1,460 AFY in the year 2030. Assuming 10% of the influent flow is lost to evaporation, the resulting recycle flows are 596 AFY rising to 1,341 AFY in the year 2030.

# 9.0 Direct Use of Recycled Water in-lieu of Groundwater Pumping

## Introduction

### Background

This alternative consists of developing a program involving delivery of recycled water from Southland WWTF to direct use as irrigation in-lieu of groundwater pumping from the principal production aquifer on Nipomo Mesa. This alternative provides for the disposition of effluent from Southland WWTP to locations other than the existing percolation ponds. Additionally, this alternative allows for an increase in operational flexibility of groundwater pumping by reducing the daily pumpage requirements.

### Objective

As proposed, this scenario will provide for the transfer of a non-potable water source (reclaimed water from Southland WWTF) to users for direct reuse in irrigation of crops or turfgrass. The net available groundwater made available by this exchange would either be: (1) directly pumped (at the subject wells) and transmitted for use by NCSD; or (2) indirectly extracted by NCSD at existing or new well locations. Therefore, this scenario will effectively function as a groundwater management program and not a true supplemental water alternative.

The objectives of this alternative include:

- Stabilize and elevate existing groundwater pumping depressions; and
- Prolong useful life of existing NCSD wells.



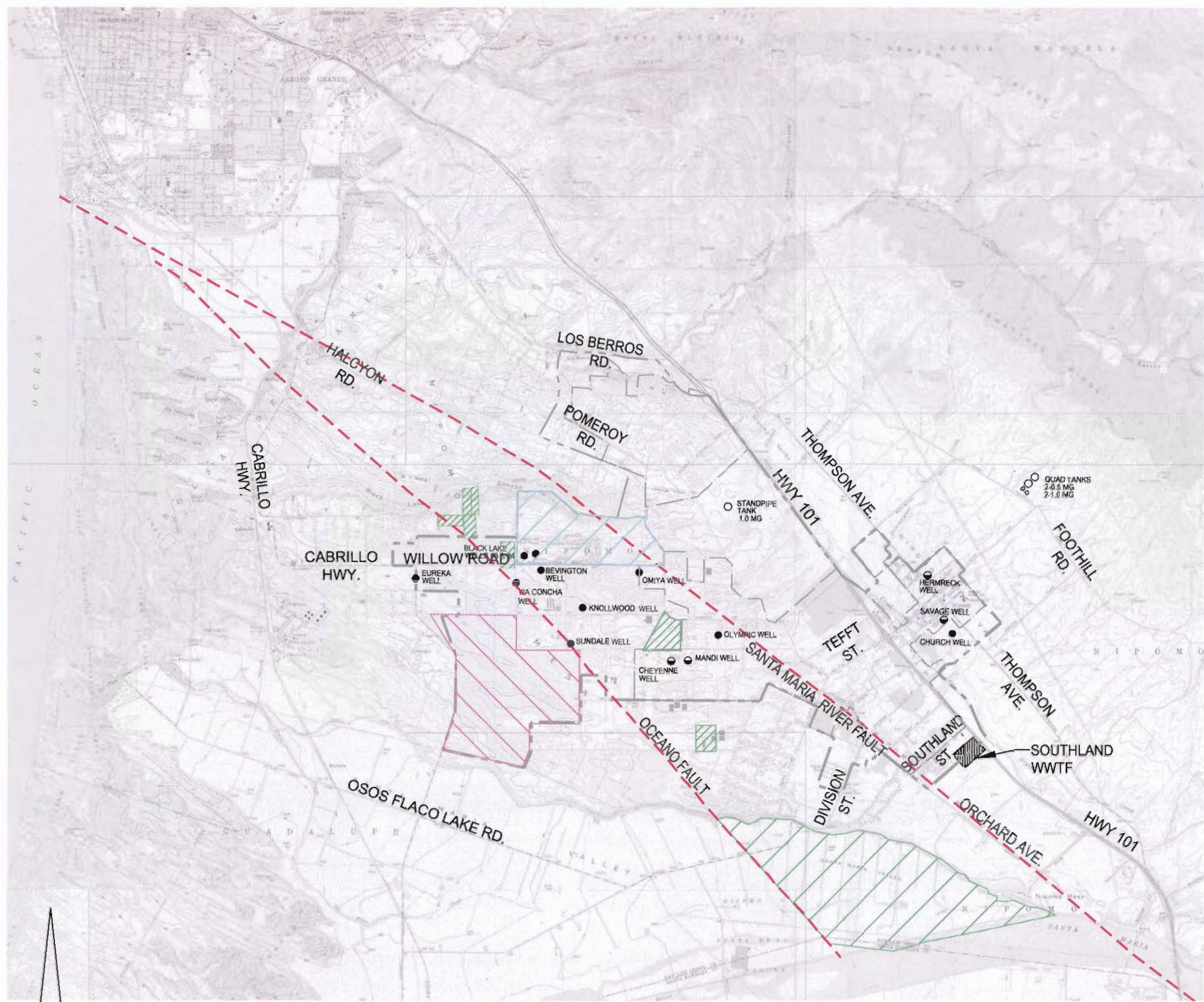





DWG: W:\Nipomo CSD (19996)\19996.32 (Alternative Water Supply)\CAO\Design\Revised Figures and Plates\Figure 9-1\_Groundwater Evaluation for Direct Reuse.dwg  
 DATE: Jun 11, 2007 8:56am XREFS: BASE MAP Well Sites  
 USER: cromero  
 Map1.TIF Map2.TIF Map3.TIF Map4.TIF Map5.TIF Map6.TIF Map7.TIF Map8.TIF Map9.TIF Map10.TIF Map11.TIF Map12.TIF Map13.TIF  
 SCAN951\_00



**NOTES:**

1. AGRICULTURAL LAND USE IS BASED ON THE SOUTH COUNTY-INLAND PLANNING AREA RURAL LAND USE CATEGORY AND COMBINING DESIGNATION MAP.

**LEGEND**

-  NIPOMO CSD WELLS
-  NIPOMO CSD WELLS (STANDBY)
-  NIPOMO CSD TANKS
-  FUTURE WATER SYSTEM SERVICE AREA BOUNDARY
-  EXISTING WATER SYSTEM SERVICE AREA BOUNDARY
-  APPROXIMATE FAULT LINE
-  AGRICULTURAL LAND USE AREA BETWEEN FAULTS
  - 1443 ACRES IN VALLEY
  - 181 ACRES ON MESA
-  BLACKLAKE DEVELOPMENT
-  WOODLANDS DEVELOPMENT

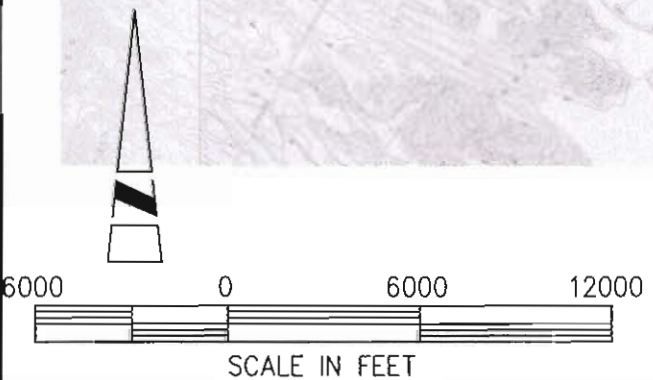

**NIPOMO CSD EVALUATION OF SUPPLEMENTAL WATER ALTERNATIVES**  
 DIRECT USE OF RECYCLED WATER IN-LIEU OF GROUNDWATER RECHARGE

BEC PROJECT NO.  
 19996.32

FIGURE  
**9-1**

## Previous Studies/Documents

The following list summarizes the studies and documents referenced for this evaluation:

- Southland Wastewater Treatment Facility Master Plan (Boyle Engineering, Draft February 2007)
- Groundwater in Storage Underneath the Nipomo Mesa Management Area As of April 2006, Draft Technical Memorandum (SAIC, October 11, 2006)
- Nipomo Mesa Current and Projected Demands and Potential for Seawater Intrusion, Draft Technical Memorandum (SAIC, October 24, 2006)
- Urban Water Management Plan 2005 Update (SAIC, January 2006)
- Phase V Stipulation of the Santa Maria Groundwater Litigation (June 30, 2005)
- Nipomo Mesa Groundwater Resource Capacity Study (SS Papadopoulos, March 2004)
- Water Resources of the Arroyo Grande - Nipomo Mesa Area (DWR Southern District, 2002)
- Final Report: Evaluation of Water Supply Alternatives (Kennedy/Jenks, October 2001)
- Evaluation of Alternative Water Supplies (Bookman-Edmonston, July 1994)

## Supply

### Small Increase in “Supply”:

The proposed groundwater exchange alternative is intended to function as a groundwater management program within the subject area of the NMMA. No, or very little, increase in supply to the District would result because the net effect of this type of exchange is much smaller than the volume of water exchanged. Figure 9-2 shows a water balance for a hypothetical exchange of 10 units of water. The assumptions used in this water balance include: (1) 20% of irrigation water returns to the aquifer, while the remainder is lost through evapotranspiration or shipped out of the NMMA as agricultural product, (2) approximately half the water demand of the District is used for irrigation with the remainder going to wastewater treatment, and (3) approximately 90% of water applied to the existing Southland WWTP reaches the aquifer, the remainder being lost to evaporation. As shown, the net impact of an exchange of 10 units of water is a net gain of one unit to the underlying aquifer. Small changes in the assumptions would alter this result slightly, but not significantly.

BEFORE

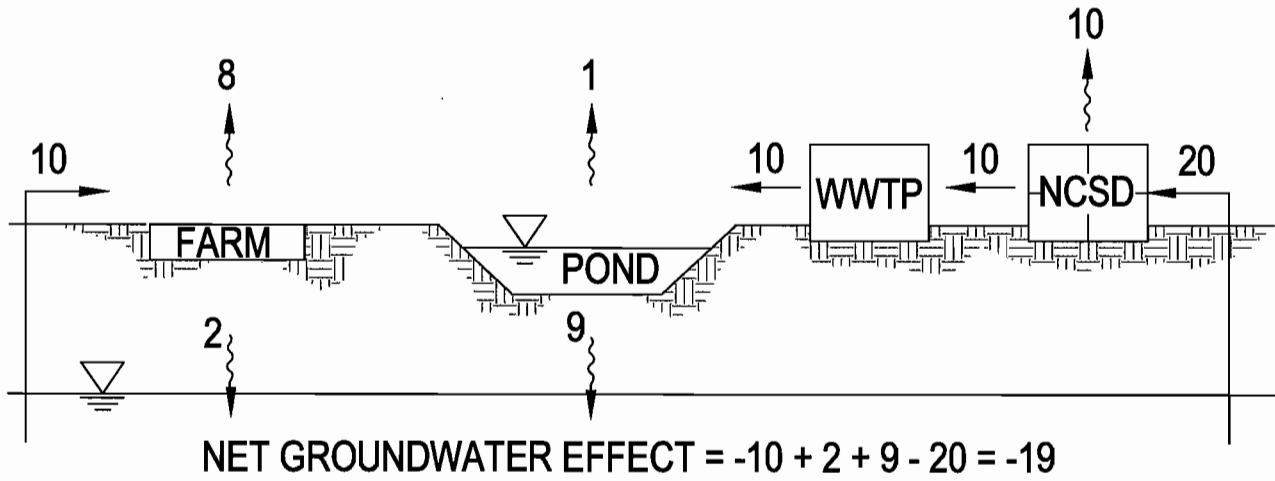

AFTER

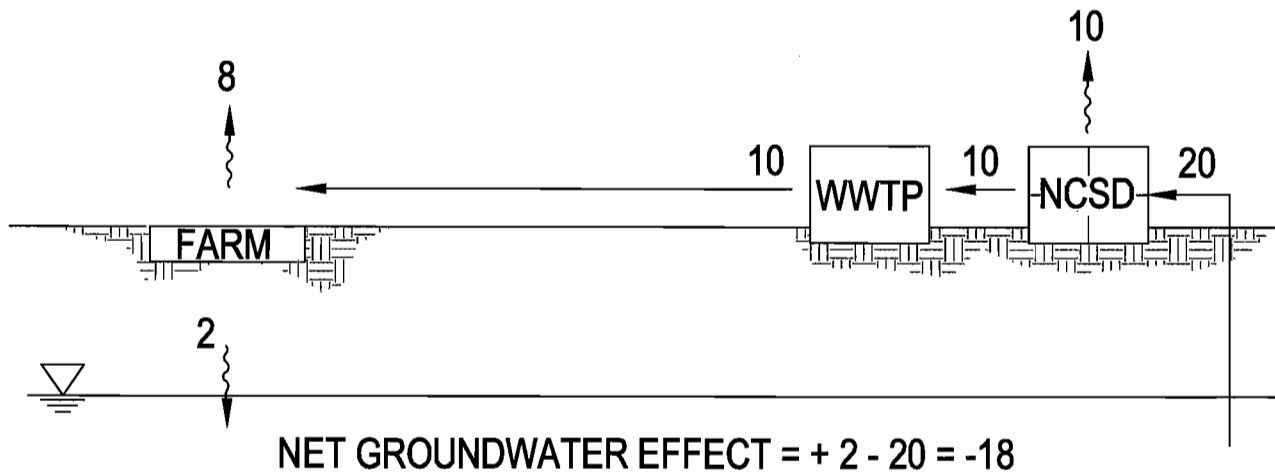

TOTAL GROUNDWATER GAIN = (AFTER - BEFORE) =  $-18 - (-19) = +1$

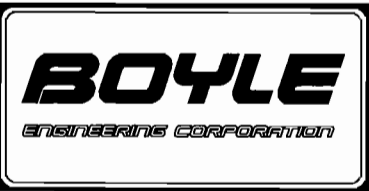

NIPOMO COMMUNITY SERVICES DISTRICT  
 NET EFFECT OF DIRECT USE OF RECYCLED WATER IN-LIEU OF GROUNDWATER PUMPING  
 Copy of document found at www.NoNewWipTax.com

BEC PROJECT NO.  
 19996.32

FIGURE  
 9-2

As no new supplemental water will be imported from outside the NMMA, there will be no effect on the overall water balance within the NMMA. However, there may be some benefit to the specific study area, previously described as the depressed groundwater basin within the NMMA if agricultural pumping from this location is decreased.

#### Quantity Available from Southland WWTF:

Average annual flow rates to the Southland WWTP are currently 0.59 MGD, equivalent to approximately 662 acre-feet per year (AFY). These flows are projected to increase to 1,460 AFY (1.3 MGD) in the year 2030. For the purpose of this analysis, it is assumed effluent flows, and therefore flows discharged to the infiltration basins, are equivalent to the existing and projected influent flows.

#### Agricultural Demand for Applied Water:

Multiple attempts have been made in previous studies to estimate total demand for applied agricultural irrigation water for varying boundaries within the Nipomo Mesa. The estimated use in 1995 ranges between 1,600 AFY (2002 DWR) and 3,780 AFY (2003 SAIC), while projected use in 2020 ranges from 1,600 AFY (2002 DWR) to 4,410 AFY (2003 SAIC). The variation in these estimates can be explained by differences in the area studied and differences in method and assumptions used.

The range of agricultural demand values was used to develop a recycled water demand duty factor for estimating potential recycled water demand as follows:

- Average of historical and projected applied demands =  $(1,600 + 4,410 \text{ AFY})/2 = 3,005 \text{ AFY}$
- Approximate Agricultural land use in Nipomo Mesa per 2002 DWR study, Table 4 = 1,220 Acres (as of 1995)
- Agricultural irrigation demand duty factor =  $3,005 \text{ AFY}/1,220 \text{ Acres} \cong 2.5 \text{ feet/year}$

The potential recycled water demand within the studied area will likely be lower than the total agricultural demand for applied water. Assume 50% of the agricultural users switch to recycled water:

- Recycled water demand duty factor =  $50\% \times 2.5 \text{ feet/year} = 1.25 \text{ ft/year}$ .

This duty factor was then applied to the agricultural zoned parcels within the confines of the study area shown on Figure 9-1:

- Area on Figure 9-1 in agricultural operation = 181 acres
- Estimated recycled water demand within studied area =  $1.25 \text{ ft/year} \times 181 \text{ acres} = 226 \text{ AFY}$ .

#### Landscape Demand for Applied Water:

The Woodlands development plans to use a mixture of treated wastewater and well water to irrigate its golf course and landscaped areas. Total water demand for this mixed water for village landscaping,

business park, golf course, and evaporation from lined ponds is estimated at 824 AFY. The water demand for the development as a whole is estimated to be 1,583 AFY, while the wastewater plant is sized to treat 394 AFY (SLO County, 1998). Therefore, approximately 425 AFY of well water will be mixed with treated wastewater and used for irrigation, and may be available for exchange under this alternative.

The Blacklake development also includes a golf course and residential development, a dedicated wastewater treatment plant, and uses a mixture of treated wastewater and well water to irrigate its golf course and landscaped areas. With a total water demand of 450 AFY, assuming similar rates of wastewater generation and irrigation gives a rough estimate of 130 AFY of well water that is now mixed with treated wastewater for irrigation. This quantity may be available for exchange under this alternative.

Therefore it is estimated that 781 AFY (rounded to 800 AFY for this analysis) would be available for exchange under this alternative.

## Quality

The proposed groundwater exchange may have negative impacts to water quality in the local, underlying aquifer due to salt accumulation. The following two criteria were considered in evaluating the quality of water resources proposed for exchange in this alternative:

- Quality of recycled water from Southland WWTF
- Quality of available groundwater for exchange within studied area

### Recycled Water from Southland WWTF:

The Southland WWTF provides secondary treatment for wastewater generated within the Nipomo community. Constituents in treated wastewater from the Southland WWTF that may affect recycled water suitability for irrigation of crops or landscape species include salts or “total dissolved solids” (TDS, often estimated by the measurement of electrical conductivity, EC<sub>w</sub>), sodium adsorption ratio (SAR), bicarbonates, chlorides, and boron. SAR is a measure of sodium hazard and is also used to predict reductions in soil permeability following application. Chlorides, boron, and sodium are ions that can reach toxic concentrations. Different crops vary in their tolerance to these constituents.

Constituents in Southland WWTF effluent with concentrations that may be problematic to crops include:

- Chloride
- Total Nitrogen (excess N may affect production of certain crops)
- TDS

- Sodium

Effluent quality data regarding boron, bicarbonates, ECw, and SAR has not been collected. This data would be required to confirm suitability of reclaimed water for irrigation.

Title 22 of the California Code of Regulations (CCR) provides regulations for median and maximum total coliform limits in reclaimed water as well as usage restrictions. These regulations are driven by concerns for public safety and do not address suitability of reclaimed water for irrigation of crops. It is anticipated NCS D will attempt to meet the most stringent requirements in order to provide flexibility for all uses allowed under the Title 22 criteria.

#### Exchange Groundwater:

It is assumed the exchange groundwater will likely be pumped from existing NCS D wells. Therefore, water quality should be similar to existing groundwater pumped from within the NMMA.

If groundwater were pumped directly from an exchange participant's wells, and if no confining layer were present between the pumped aquifer and the place of application, water quality of the pumped groundwater could be impacted by the percolation of applied recycled water.

## **Reliability**

#### Recycled Water from Southland WWTF:

Recycled water is considered a reliable water supply. However, its reliability as it pertains to exchange for direct use is contingent on the NCS D's ability to provide and maintain recycled water quality meeting the appropriate standards as well as taking additional necessary measures to mitigate salt accumulation in the groundwater basin.

#### Exchange Groundwater:

The groundwater will be extracted by existing or new NCS D wells, or by the exchange participant's wells. Therefore, the reliability of the return flows will be approximately the same as the existing groundwater supply. Therefore, its reliability may be hindered by drought conditions within the NMMA and any further development/expansion of the pumping depressions.

## **Required Facilities**

In order to utilize its wastewater discharge as a resource, it is expected the NCS D will attempt to upgrade its treatment to provide Tertiary Recycled Water for Unrestricted Irrigation. As noted above, this level of treatment will require oxidation, coagulation, filtration and disinfection. The NCS D may



also need to consider blending the recycled water with higher quality groundwater in order to reduce TDS and other constituents of concern. In order to convey its recycled water to agricultural users, the NCSD would also need to construct storage, pumping, and transmission pipeline facilities.

Depending on the location(s) of potential agricultural users, the NCSD may also need to construct pumping and transmission facilities to convey pumped groundwater from the subject agricultural sites to interconnect with existing NCSD facilities. It is also possible NCSD may need to upgrade some of its existing water pumping, treatment, and transmission facilities. The extent of required upgrades is currently unknown.

### Project Components:

For the purposes of comparison within the scope of this constraints analysis, the following facilities are assumed to be required to implement groundwater exchange of recycled water for agricultural production:

- Upgrades to Southland WWTF to provide Tertiary Recycled Water, including filtration and disinfection;
- Storage facilities at Southland WWTF, booster pump station(s), and transmission pipelines to convey recycled water to agricultural users; and
- Transmission facilities to convey pumped “exchange groundwater” from agricultural sites to NCSD facilities
- Upgrades to existing water pumping, treatment, and transmission facilities.

## **Implementation Schedule**

It is estimated approximately 2 to 4 years will be required to fully implement this project.

## **Constraints**

### Institutional

Public perception with the use of recycled water for irrigation of food crops, non-food crops, and recreation areas may reduce the demand for recycled water.

### Legal

NCSD will need to identify interested parties and enter into agreements with users.

Assuming 10% of this groundwater exchange is considered *New Developed Water* as defined in the Phase V Settlement Stipulation, NCSD may be required to obtain an order from the Court, quantifying

and allocating the rights to the New Developed Water, before they have the prior right to the New Developed Water.

### Regulatory

In order to allow for unrestricted irrigation of crops, NCS D will need to upgrade its treatment to provide Tertiary Recycled Water. This level of treatment meets the most stringent of Title 22 criteria. NCS D will also need to revise the Waste Discharge Requirements for Southland WWTF to allow reuse of plant effluent for unrestricted urban use.

NCS D will need to satisfy the requirement of a Title 22 Engineering Report for DHS/RWQCB review.

The construction of an expanded treatment system, pipelines, percolation basins, and pumping facilities will require permits from local and state agencies.

### Cost

The probable cost of improvements is approximately \$19 million and includes treatment and conveyance facilities. Amortizing this cost over 20 years and including approximately \$40,000 in annual operational costs brings the total annual cost to \$1.7 million. This alternative recycles 800 AFY of treated wastewater, but is expected to produce only 80 AFY of “new” return flows. Therefore, the cost per acre-foot of “new” water is \$21,000.

### Capacity

Assuming that the Woodlands, Black Lake, and 50% of the agricultural users overlying the groundwater depression were to switch to irrigation with 100% recycled water, the total demand would be approximately 800 AFY. Average annual flow rates to the Southland WWTF are approximately 662 AFY, and are projected to increase to 1,460 AFY in the year 2030. Therefore, adequate supply does not now exist to make full use of this alternative, but is expected to become available within 20 years.

However, as noted above, it is reasonable to assume that for every 10 units of water exchanged, only one additional unit of groundwater would be made available. Therefore, at full capacity of 800 AFY exchange, perhaps as little as 80 AFY of additional water from the NMMA would be available.

# 10.0 Summary of Water Quality

The following table provides a summary of water quality for some of the alternatives considered. State and national drinking water standards (i.e., Primary and Secondary Maximum Contaminant Levels) are also provided.

**Nipomo Community Services District Evaluation of Supplemental Water Alternatives**  
**Table 10-1 Summary of Water Quality Data & Drinking Water MCL's**

	CDHS MCL	USEPA MCL	Lake Nacimiento <sup>1</sup>			CCWA State Water (from PPWTP) <sup>2</sup>						Nipomo Community Services District - Town Division <sup>3</sup>						Santa Maria River Surface Water @ Bull Canyon Road <sup>4</sup>			Cuyama Lane Water Company Well <sup>5</sup>	City of Santa Maria Wells <sup>6</sup>							
			See note 1			2005			2006			2005			2006			6/1/2000			2006	2005			2006				
			Min	Max	Avg	Min	Max	Avg	Min	Max	Avg	Min	Max	Avg	Min	Max	Avg	Min	Max	Avg	Only one sample	Min	Max	Avg	Min	Max	Avg		
<b>Primary Standards</b>																													
Aluminum (Al), ppm	1				0.05	0.26	0.11	0.049	0.220	0.128	--	0.4	0.067																
Antimony, ppm	0.006											2	--																
Arsenic (As), ppb	50	10										57	7.7	--	8	2.3													
Asbestos, MFL	7	7			4/1/1998																								
Barium (Ba), ppm	1	2										0.0223	0.062	0.0419															
Beryllium, ppm	0.004	0.004																											
Cadmium (Cd), ppm	0.005	0.005										0.0009	0.00046																
Total Chlorine Residual, ppm					2	3.1	2.5	0.95	3.2	1.8																			
Chromium, ppm	0.05											0.007	0.0016																
Coliforms, Fecal MPN/100mL																													
Coliforms, Total, MPN/100mL																													
Copper, ppm																													
Cyanide, ppm	0.15																												
Fluoride, ppm	2	4						0.1		0.06		3	0.16																
Haloacetic acids (HAA), ppb	60	60			8.5	24.0	15.0	5.8	17.0	10.2																			
Lead, ppm	0.015	0.015																											
Mercury, ppb	2	2										0.02	0.04	0.032															
MTBE, ppm	0.013																												
Nickel, ppm	0.1											0.004	--																
Nitrate (as nitrogen), ppm	45	10			1.8	7.6	4.44			1.6	--	24.4	6.79	--	11.6	5.1	0.223	2.225	1.174	4/1/2001									
Nitrate+Nitrite (sum of nitrogen), ppm	10						0.51			0.37							0.05	0.7	0.417										
Nitrite (as nitrogen), ppm	1	1															0.015	0.05	0.037										
Perchlorate, ppb																													
Selenium (Se), ppm	0.05	0										0.004	--																
Thallium, ppm	0.002	0.002																											
Total organic carbon, ppm			2.8	4.4	4	1.4	4.5	2.4	1.3	2.6	1.8																		
Trichloroethylene (TCE), ppb	5	5																											
Total trihalomethanes (THM), ppb	80	80			37	72	53	25	47	36	--	3.1	--																
<b>Secondary Standards</b>																													
Aluminum (Al), ppm	0.2	0.05 - 0.2			0.05	0.26	0.11					0.4	0.067																
Apparent Color (Unfiltered)	15	15								3		30	--																
Chloride, ppm	250-500	250			21	125	65	21	125	52	43	106	58	44	106	59	20.3	86.6	53.6	4/1/2001									
Copper, ppm	1																												
Corrosivity (Langlier Index)			-1.5	0.5	-0.5																								
Iron (Fe), ppb	300	300	31	2,800	1,416							1270	204																
Manganese, ppm	0.05	0.05	0	0.640	0.320							0.050	--																
MTBE, ppm	0.005																												
Odor Threshold	3	3			1	3	1	1	3	1																			
Specific Conductance, umhos/cm	900				268	730	467	206	666	360	455	1410	903	554	1410	948	983	1610	1,211										
Sulfate (SO4), ppm	250-500	250					58			39	39	332	216	59	332	240	370	540	455	4/1/2001									
TDS, ppm	500	500			131	358	239	97	326	172	300	950	645	340	920	676	666	1210	898										
Turbidity, NTU	5		0.7	74	37	0.03	0.12	0.06	0.03	0.26	0.04	--	17.2	2.58			3	350	86										
Zinc, ppm	5	5																											
<b>Radioactivity</b>																													
Gross Alpha Particle Activity, pCi/L	15	15										8.5	3.65																
Gross Beta Particle Activity, mrem/yr	4	4											0.394																
Radium-226, pCi/L																													
Radium-228, pCi/L																													
Combined Radium-226 and Radium-228, pCi/L	5	5																											
Strontium-90, pCi/L	8																												
Tritium, pCi/L	20000																												
Uranium, pCi/L	20	30 ug/L										0.11	5.37	3.75															
<b>Additional Parameters</b>																													
Alkalinity, mg/L as CaCO3			74	130	102	42	76	63	34	80	57																		
Bicarbonate, ppm																													
Boron, ppm																													
Bromofom, ppb																													
Blue Green Algae, #/mm <sup>2</sup>			0	232	116																								
Calcium (Ca), ppm			20	38	29	28	74	50	24	68	42						99	155	125	4/1/2001									
Chromium VI, ppb																													
DCPA Di+Mono Acid, ppb																													
Dibromochloromethane																													
Free CO2, ppm			1.2	63	32																								
Hardness as CaCO3, ppm						50	140	98	42	120	76	106	552	343	134	552	351	465	806	576	4/1/2001								
Heterotrophic Plate Count, CFU/mL						<1	2	1	<1	2	1																		
Manganese, ppm																													
Magnesium (Mg), ppm								12		9.5																			
Odor, Tons																													
pH		6.5-8.5	6.54	8.86	8	6.7																							

# 11.0 Comparison of Alternatives

In this section each of the seven alternatives under consideration is compared to the Waterline Intertie Project. Separate comparisons are made concerning supply, water quality, reliability, and the time required to implement, as well as institutional, legal, and regulatory constraints.

Each alternative receives a score (1=best; 8=worst). These scores are then combined and a numerical ranking of alternatives is presented.

## Supply

Ability to provide 3,000 AFY or 6,300 AFY

	Constraints	Supply	
	Alternative	Notes	Score
1	Santa Maria Valley Groundwater	Sufficient supply exists.	1
2	CCWA, State, or "Other" Water	Sufficient supply exists.	1
3	Desalination of Sea Water/Cooling Water	Sufficient supply exists.	1
4	Brackish Agricultural Drainage from Oso Flaco Watershed	440 to 968 AFY, assumed constrained by ag. return flows.	6
5	Nacimiento Water Project Extension	2,148 AFY	5
6	Recharge of Groundwater with Recycled Water from Southland WWTF	No Increase in Supply	8
7	Groundwater Exchange of Recycled Water for Direct Reuse	No or Very Little Increase in Supply	7
8	Waterline Intertie Project	Sufficient supply exists, with minor improvements to expand to 6,300 AFY	1

## Water Quality

	<b>Constraints</b>	<b>Water Quality</b>	
	<b>Alternative</b>	<b>Notes</b>	<b>Score</b>
1	<b>Santa Maria Valley Groundwater</b>	Insufficient data available. High TDS and nitrate may be a concern. Proximity to river makes treatment a likely requirement.	4
2	<b>CCWA, State, or "Other" Water</b>	Treated to Municipal Standards. Uses chloramines for disinfection, while District uses chlorine.	1
3	<b>Desalination of Sea Water/Cooling Water</b>	Depends on source. Seawater has history of successful treatment with RO. Cooling water may require additional treatment.	7
4	<b>Brackish Agricultural Drainage from Oso Flaco Watershed</b>	Poor water quality. Does not support "Municipal Water Supply" in Basin Plan.	8
5	<b>Nacimiento Water Project Extension</b>	Raw surface water from Lake Nacimiento	3
6	<b>Recharge of Groundwater with Recycled Water from Southland WWTF</b>	Salt, nitrogen, and other contaminants will require additional treatment upgrade at Southland WWTP	6
7	<b>Groundwater Exchange of Recycled Water for Direct Reuse</b>	Salt, nitrogen, and other contaminants will require additional treatment upgrade at Southland WWTP	5
8	<b>Waterline Intertie Project</b>	Santa Maria disinfects using chloramines. District would need to remove chloramines from new water, or convert existing system to chloramines.	1

## Reliability

	<b>Constraints</b>	<b>Reliability</b>	
	<b>Alternative</b>	Notes	Score
1	<b>Santa Maria Valley Groundwater</b>	Reliability is good.	5
2	<b>CCWA, State, or "Other" Water</b>	Reliability depends on amount of allocation acquired. Long term average delivery = approx. 75% of allocation.	6
3	<b>Desalination of Sea Water/Cooling Water</b>	Reliability is good.	1
4	<b>Brackish Agricultural Drainage from Oso Flaco Watershed</b>	Unknown. More study required.	8
5	<b>Nacimiento Water Project Extension</b>	Reliability is considered good.	6
6	<b>Recharge of Groundwater with Recycled Water from Southland WWTF</b>	Reliability is similar to existing groundwater supply.	3
7	<b>Groundwater Exchange of Recycled Water for Direct Reuse</b>	Reliability is similar to existing groundwater supply.	3
8	<b>Waterline Intertie Project</b>	Reliability is considered good.	1

## Implementation Schedule

	<b>Alternative</b>	<b>Time Required</b>	<b>Score</b>
<b>1</b>	<b>Santa Maria Valley Groundwater</b>	4 to 6 years	4
<b>2</b>	<b>CCWA, State, or "Other" Water</b>	4 to 6 years	4
<b>3</b>	<b>Desalination of Sea Water/Cooling Water</b>	6.5 to 10.5 years	7
<b>4</b>	<b>Brackish Agricultural Drainage from Oso Flaco Watershed</b>	7 to 10 years	8
<b>5</b>	<b>Nacimiento Water Project Extension</b>	5 to 7 years	6
<b>6</b>	<b>Recharge of Groundwater with Recycled Water from Southland WWTF</b>	2 to 4 years	2
<b>7</b>	<b>Groundwater Exchange of Recycled Water for Direct Reuse</b>	2 to 4 years	2
<b>8</b>	<b>Waterline Intertie Project</b>	2 to 3 years	1



## Institutional Constraints

	<b>Constraints</b>	<b>Institutional Constraints</b>	
	<b>Alternative</b>	Notes	Score
1	<b>Santa Maria Valley Groundwater</b>	Need to purchase water rights from SMVMA user.	3
2	<b>CCWA, State, or "Other" Water</b>	Need approval from numerous institutions and voters. May be required to buy into past costs.	5
3	<b>Desalination of Sea Water/Cooling Water</b>	Will require cooperation with participants and/or affected landowners.	2
4	<b>Brackish Agricultural Drainage from Oso Flaco Watershed</b>	Lake is owned by State Parks, who would likely oppose extraction.	6
5	<b>Nacimiento Water Project Extension</b>	Need to act quickly if costs will be shared. <b>FATAL FLAW</b> (Project is out to bid.)	8
6	<b>Recharge of Groundwater with Recycled Water from Southland WWTF</b>	Public perception issues for use of recycled water and siting of percolation ponds.	7
7	<b>Groundwater Exchange of Recycled Water for Direct Reuse</b>	Public perception issues for use of recycled water may block implementation.	4
8	<b>Waterline Intertie Project</b>	MOU with City of Santa Maria is in place.	1

## Legal Constraints

	<b>Constraints</b>	<b>Legal Constraints</b>	
	<b>Alternative</b>	<b>Notes</b>	<b>Score</b>
1	<b>Santa Maria Valley Groundwater</b>	Need to satisfy pending groundwater adjudication. Pumping at boundary may not be possible. <b>FATAL FLAW.</b>	8
2	<b>CCWA, State, or "Other" Water</b>	Will need to hold an election. Will need contracts to purchase water.	7
3	<b>Desalination of Sea Water/Cooling Water</b>	Will require contracts between cooperating participants (if any).	2
4	<b>Brackish Agricultural Drainage from Oso Flaco Watershed</b>	Part of the Santa Maria Valley Management Area, therefore requires approval of all litigants.	6
5	<b>Nacimiento Water Project Extension</b>	Need to execute appropriate contracts.	3
6	<b>Recharge of Groundwater with Recycled Water from Southland WWTF</b>	No "new supply" created.	4
7	<b>Groundwater Exchange of Recycled Water for Direct Reuse</b>	Would need court judgement to use any "new" water created.	5
8	<b>Waterline Intertie Project</b>	(None identified)	1

## Regulatory Constraints

	<b>Constraints</b>	<b>Regulatory Constraints</b>	
	<b>Alternative</b>	Notes	Score
1	<b>Santa Maria Valley Groundwater</b>	Use of Twitchell reservoir water will require DWR license modification. DHS will require treatment.	6
2	<b>CCWA, State, or "Other" Water</b>	Treatment will require DHS approval. Minor resource agency oversight expected.	1
3	<b>Desalination of Sea Water/Cooling Water</b>	Coastal Commission, State Lands, and Resource Agencies' concerns will need to be addressed. Cooperating parties will require mutual agreements. DHS/RWCB permits will be required.	8
4	<b>Brackish Agricultural Drainage from Oso Flaco Watershed</b>	DHS would consider this an "Extremely impaired Source." Significant resource agency regulatory involvement expected.	7
5	<b>Nacimiento Water Project Extension</b>	CEQA via Supplemental EIR required. Resource agency permits required for construction. State and federal drinking water regulations would apply to treatment plant.	3
6	<b>Recharge of Groundwater with Recycled Water from Southland WWTF</b>	Requires new WDR for Southland WWTP, increased regulatory burden for recharging groundwater with recycled water, as well as nominal construction permitting.	5
7	<b>Groundwater Exchange of Recycled Water for Direct Reuse</b>	Requires new WDR for Southland WWTP, increased regulatory burden for using recycled water, as well as nominal construction permitting.	4
8	<b>Waterline Intertie Project</b>	State and federal drinking water regulations would apply to disinfection improvements. Resource agency permits required for construction.	1

## Numerical Ranking of Alternatives

	<b>Constraints</b>	<b>Summary</b>		
	<b>Alternative</b>	<b>Total Score</b>	<b>Rank</b>	<b>Biggest Obstacle</b>
1	<b>Santa Maria Valley Groundwater</b>	29	4	<b>FATAL FLAW</b> Need to satisfy adjudication.
2	<b>CCWA, State, or "Other" Water</b>	24	2	Supply is limited and unreliable. Need significant political and institutional support.
3	<b>Desalination of Sea Water/Cooling Water</b>	28	3	Permitting from Coastal Commission and other Resource Agencies
4	<b>Brackish Agricultural Drainage from Oso Flaco Watershed</b>	49	8	Insufficient Supply and Poor Water Quality
5	<b>Nacimiento Water Project Extension</b>	29	4	<b>FATAL FLAW</b> Project is out to bid.
6	<b>Recharge of Groundwater with Recycled Water from Southland WWTF</b>	37	7	Not a new source.
7	<b>Groundwater Exchange of Recycled Water for Direct Reuse</b>	32	6	Insufficient supply.
8	<b>Waterline Intertie Project</b>	10	1	Capital Cost

# 12.0 Conclusions

## Comparison of Alternatives

As discussed in previous sections, the following alternatives appear to have “fatal flaws” that would prevent the District from pursuing them as viable, supplemental water sources:

**Santa Maria Valley Groundwater** – This alternative would likely affect the flow of water between Santa Maria Valley and the NMMA, and would likely be prevented as a result of the adjudication.

**Nacimiento Water Project Extension** – The Nacimiento Water Project is currently out to bid, and as designed would not deliver the District’s desired 3000 AFY. Revisions to the project would cost at least \$4000 per AF for extending the pipeline from City of San Luis Obispo to Nipomo, not including costs to increase the pipeline upstream of San Luis Obispo to expand capacity and deliver 3000 AFY.

**Oso Flaco Drainage** - Although drainage from Oso Flaco could be treated, and this alternative does not have any “fatal flaws”, it is not considered to be a feasible supplemental water alternative due to the poor water quality of the water, inadequate quantity, likelihood of requiring approval from parties in Santa Maria Valley adjudication, and lack of support expected from CDHS.

**Groundwater Recharge or Reuse** - Groundwater recharge of treated wastewater, and direct reuse of this resource, will not increase the water supply available to the District, but may assist with managing groundwater depressions and with providing a market for treated plant effluent because onsite discharge may no longer be desired at Southland WWTF.

**Seawater Desalination** - Seawater desalination is expected to take many years for implementation, would be an expensive water supply, and would require many years of studies and negotiation with resource agencies, but would represent the most reliable water supply available to the District. While this may not meet the District’s short-term need for water, it is recommended that the District consider desalination in long-term water supply planning. Desalination will be addressed in more detail in Task 3 of this evaluation.

**State Water or “Other” Water** - Although direct purchase of 3,000 AFY or 6,300 AFY of State Water from the SWP pipeline does not appear to be feasible, due to institutional and legal constraints, acquiring off-peak or excess capacity and storing that water in an aquifer storage-recovery facility may be viable. This alternative will be explored in greater detail in Task 2 of this evaluation, and the evaluation will benefit from an ongoing analysis of the Natomas water exchange (currently being conducted by Hatch & Parent, as mentioned previously).

## Summary of Relative Costs

Although detailed cost opinions were not developed in this evaluation, cost is considered one of the primary criteria for determining whether alternatives are feasible. The planning-level \$/AFY costs developed in previous sections, along with notes identifying any unsubstantiated but expected costs, are summarized below.

**Table 12-1 Relative Costs per Acre-Foot**

	<b>Alternative</b>	<b>Facilities and O&amp;M</b>	<b>Water Purchase</b>	<b>Other</b>	<b>Total</b>
1	<b>Santa Maria Valley Groundwater</b>	\$520 to \$770	\$1,250 <sup>(1)</sup>	Site purchase at Hutton or Oso Flaco Road	\$1,770 to \$2,020 plus land cost
2	<b>CCWA, State, or "Other" Water</b>	\$130 to \$380	\$1,500 <sup>(2)</sup>	\$436/af <sup>(2)</sup> refinance past capital costs	\$2,070 to \$2,310
3	<b>Desalination of Sea Water/Cooling Water</b>	\$2,200 to \$2,600	0	Site purchase or lease cost	\$2,200 to \$2,600 plus land cost
4	<b>Brackish Agricultural Drainage from Oso Flaco Watershed</b>	\$2,300 to \$2,700	0	Site purchase or lease cost	\$2,300 to \$2,700 plus land cost
5	<b>Nacimiento Water Project Extension</b>	\$1,100 <sup>(3)</sup>	\$1,900 to \$2,100 <sup>(4)</sup>	\$1,000 + for storage, pumping and treatment	\$4,000 or more
6	<b>Recharge of Groundwater with Recycled Water from Southland WWTF</b>	\$1,100 to \$2,320 per AF recycled (No new water supplied)		Site purchase for percolation basins	\$1,100 to \$2,320 plus land cost
7	<b>Groundwater Exchange of Recycled Water for Direct Reuse</b>	\$21,000 (80 AFY new water)			\$21,000
8	<b>Waterline Intertie Project</b>	\$470 to \$850	\$1,250		\$1,720 to \$2,100

(1) Assumed equal to MOU purchase price.

(2) Carpinteria sale to PXP (CVWD, 2006).

(3) Transmission main only from SLO City turnout.

(4) Assumed equal to estimated cost for delivery to SLO City turnout.

# References

## Reports/Documents

American States Water Company and Golden State Water Company, Securities and Exchange Commission Form 10-K for Annual and Transition Reports Pursuant to Sections 13 or 15(d) of The Securities Exchange Act of 1934, Fiscal Year Ending December 31, 2006

Beychok, Milton R. (1967). Aqueous Wastes from Petroleum and Petrochemical Plants, 1st Edition, John Wiley and Sons. LCCN 67-19834, referenced in [http://en.wikipedia.org/wiki/Water\\_cooling](http://en.wikipedia.org/wiki/Water_cooling).

Black & Veatch. Nacimiento Water Project: Technical Memorandum (TM) 8 Water Quality Investigations for San Luis Obispo County Flood Control & Water Conservation District (SLOCFCWCD), January 2006

Black & Veatch in Association with Boyle Engineering. Nacimiento Water Project: Preliminary Design Report (PDR) for SLOCFCWCD, July 2006.

Bookman-Edmonston Engineering, Inc. Evaluation of Alternative Supplemental Water Supplies, July 15, 1994. Prepared for Nipomo Community Services District

Boyle Engineering Corporation. Nipomo Waterline Intertie Project – Preliminary Engineering Memorandum (Draft), November 2006.

Boyle Engineering Corporation. Nacimiento Reservoir: Reliability As a Water Source for San Luis Obispo County, October 2002

Boyle Engineering Corporation. AIWRP Water Supply Evaluation: Nacimiento Treatment Evaluation for City of El Paso de Robles, September 2006

Boyle Engineering Corporation. Southland Wastewater Treatment Facility Master Plan, Draft February 2007

California Coastal Commission. Seawater Desalination and the California Coastal Act, March 2004.

California Department of Health Services. Groundwater Recharge Reuse DRAFT Regulation, January 4, 2007.

California Department of Water Resources. Notice to State Water Project Contractors, Article 21 Water Program for 2006, December 27, 2005.

California Department of Water Resources, Bay-Delta Office. The State Water Project Delivery Reliability Report 2005, April 2006.

California Department of Water Resources , California Water Plan Update, Bulletin 160-98 , Executive Summary, November 1998

California Department of Water Resources and SBCFC & WCD, Contract Between the State of California Department of Water Resources and SBCFC & WCD for a Water Supply (1963)

California Department of Water Resources and SLOCFC & WCD, Contract Between the State of California Department of Water Resources and SLOCFC & WCD for a Water Supply (1963)

California Regional Water Quality Control Board, Central Coast Region, 2002, Staff Report for Regular Meeting of April 19, 2002, Item 11, Reissuance Of National Pollutant Discharge Elimination System, Permit For Tosco Refining Company, Santa Maria Refinery, San Luis, Obispo County--Order No. R3-2002-0010, NPDES No. CA0000051.

Carpinteria Valley Water District. Minutes of the Regular Meeting of the Board of Directors, April 26, 2006.

Central Coast Ambient Monitoring Program (CCAMP). 312 Santa Maria River Hydrologic Unit Draft Report for Sampling Year 2000

Central Coast Water Authority. 2005 Urban Water Management Plan, October 2005.

Central Coast Water Authority. The State Water Project in Santa Barbara County, <http://www.ccwa.com/history/index.html>, 2007.

CH2MHill. 2005 Urban Water Management Plan – City of Santa Maria, Public Review Draft, February 2007.

Department of Water Resources, Southern District. Water Resources of the Arroyo Grande – Nipomo Mesa Area, 2002.

Garing Taylor & Associates. Task 25 – Results of Screening Evaluation, January 16, 2007.

Gibbs, Dennis, Hydrologist. 2005 Santa Barbara County Groundwater Report, March 28, 2006. Prepared for Santa Barbara County Public Works Water Resources Department

Kennedy/Jenks Consulting. Final Report, Evaluation of Water Supply Alternatives, October 2001. Prepared for Nipomo Community Services District

Massachusetts Institute of Technology, 2007, Environmental Virtual Campus, <http://www.c2e2.org/evc/PwrBlow.html>



Padre Associates, Inc. Supplemental Water Alternatives Environmental and Permitting Constraints Analysis, May 2007.

Penfield & Smith. Pipeline System Modeling, Tank 1 to Santa Ynez Pump Facility Definition of Available Extra Capacity, June 2006. Prepared for the Central Coast Water Authority

SAIC Engineering, Inc. Response to Boyle Engineering Questions 6-11 - Santa Maria River Underflow SAIC Project Number: 01-0236-00-9785, Draft Technical Memorandum dated June 5, 2007

SAIC Engineering, Inc. Groundwater in Storage Underneath the Nipomo Mesa Management Area as of April 2006, 01-0236-00-9100, technical memorandum dated October 11, 2006

SAIC Engineering, Inc. Nipomo Mesa Current and Projected Demands and Potential for Seawater Intrusion, Draft Technical Memorandum dated October 24, 2006

SAIC Engineering, Inc. Santa Maria River Estuary and Enhancement Management Plan, dated March, 2004. Prepared for The Dunes Center

SAIC Engineering, Inc. Urban Water Management Plan 2005 Update, Adopted January 25, 2006. Prepared for Nipomo Community Services District

SLOCFCWCD. Meeting Agendas from NWP Commission and Board of Supervisors of the SLOCFCWCD

S.S. Papadopulos & Associates, Inc. Nipomo Mesa Groundwater Resource Capacity Study, March 2004. Prepared for San Luis Obispo County

Superior Court of the State of California – County of Santa Clara, Phase V Stipulation of the Santa Maria Groundwater Litigation Case No.CV770214, June 30, 2005

URS Corporation. Final Urban Water Management Plan – Goleta Water District, December 20, 2005.

Wallace Group. Draft Supplemental Water Supply Study for Nacimiento Pipeline Extension and Desalination, January 2006. Prepared for the City of Arroyo Grande

Wallace Group. Water Supply Study: Desalination, Draft, for Oceano Community Services District, City of Arroyo Grande, and City of Grover Beach, January 2006.

## **Water Quality Data**

City of Santa Maria

City of Santa Maria. 2005 Water Source for City of Santa Maria Water Wells and Central Coast Water Authority.

City of Santa Maria. Draft 2006 Water Source for City of Santa Maria Water Wells and Central Coast Water Authority.

Central Coast Water Authority (CCWA)

Central Coast Water Authority (CCWA). Polonio Pass Water Treatment Plant 2004 through 2006 Consumer Confidence Report Data.

Cuyama Lane Water Company

San Luis Obispo County Public Health Dept., Environmental Health Services Division, Data for 2006

Nacimiento Lake

Black and Veatch. Nacimiento Water Project Technical Memo 8 - Water Quality Investigation, January 13, 2006

Boyle Engineering Corporation. AIWRP Nacimiento Treatment Evaluation, September 2006.

Nipomo Community Services District

Nipomo Community Services District. 2005 Water Quality Consumer Confidence Report.

Nipomo Community Services District. 2006 Water Quality Laboratory Test Data for Wells.

Oso Flaco Water Bodies

Cachuma Resource Conservation District and the Dunes Center. Draft Nitrate and Sediment Assessment, Oso Flaco Watershed, San Luis Obispo County, California, August 2004. Report prepared for California Regional Water Quality Control Board, Central Coast Region

Central Coast Ambient Monitoring Program (CCAMP). Water Quality Data for Hydrologic Area: Oso Flaco Creek 312OFC @ Oso Flaco Lake Road, Oso Flaco Lake 312OFL @ culvert, and Little Oso Flaco Creek 312OFN. <http://www.ccamp.org/ca300/3/312/3121/3121wb.htm>

Central Coast Regional Water Quality Control Board, San Luis Obispo, California. Summary of Santa Maria and Oso Flaco Fecal Coliform TMDL Report, December 6, 2006. Prepared for CEQA Scoping Meeting and Public Workshop for Santa Maria and Oso Flaco

Central Coast Regional Water Quality Control Board, San Luis Obispo, California. Summary of Santa Maria and Oso Flaco Nitrate and Unionized Ammonia TMDL Report, December 6, 2006. Prepared for CEQA Scoping Meeting and Public Workshop for Santa Maria and Oso Flaco

Central Coast Regional Water Quality Control Board, San Luis Obispo, California. Phase Four: Project Analyses, Final Preliminary Project Report, Total Maximum Daily Loads for Nitrate and Ammonia in Santa Maria River and Oso Flaco Creek watersheds, Santa Barbara and San Luis Obispo Counties, California, December 5, 2006.

Santa Maria River Surface or Underflow

Central Coast Ambient Monitoring Program (CCAMP). Water Quality Data for Hydrologic Area: Santa Maria River 312SBC @ Bull Canyon Road. <http://www.ccamp.org/ca300/3/312/3121/3121wb.htm>

**Personal Communication**

Ogren, Paavo, Deputy Director of Public Works, San Luis Obispo County, email to Boyle Engineering, 6-10-07.



# Appendix A - Relative Cost Comparison

For comparison purposes at this level of analysis, the following unit costs were used in developing opinions of probable costs. All costs shown include construction costs + “soft costs” (permitting, engineering, construction management) and a contingency.

<b>Description</b>	<b>Unit</b>	<b>Probable Cost per Unit</b>
<b>Capital Costs</b>		
<b>Pipe Lines - no paving</b>		
18" PVC Water Main - no paving	mile	\$ 1,490,000
24" PVC Water Main - no paving	mile	\$ 1,610,000
36" PVC Water Main - no paving	mile	\$ 1,840,000
<b>Pipe Lines - with paving</b>		
8" PVC Water Main - with paving	mile	\$ 1,350,000
18" PVC Water Main - with paving	mile	\$ 1,860,000
20" PVC Water Main - with paving	mile	\$ 1,910,000
24" PVC Water Main - with paving	mile	\$ 2,010,000
<b>Pipe Crossings</b>		
Pipe river crossing, trenched installation - 24" diameter pipe	feet	\$ 1,020
Pipe river crossing, HDD installation - 24" diameter pipe	feet	\$ 2,775
<b>Pump Stations</b>		
Pump Station, 2.7 MGD (3,000 AFY)	each	\$ 810,000
Pump Station, 5.7 MGD (6,300 AFY)	each	\$ 1,700,000
<b>Storage</b>		
Tank, Site Improvements and Appurtenances	gallon	\$ 2.00
<b>Connections</b>		
Inteconnection Facility, 2.7 MGD	each	\$ 15,000
Inteconnection Facility, 5.7 MGD	each	\$ 30,000
CCWA Turnout	each	\$ 500,000
<b>Intake/Discharge Structures</b>		
Well, 0.89 MGD	each	\$ 175,000
Ocean Outfall, 2.7 MGD	each	\$ 18,900,000
Ocean Outfall, 5.7 MGD	each	\$ 21,500,000
Percolation Basin improvements (no land cost)	acre	\$ 100,000
<b>Treatment Facilities</b>		
Reverse Osmosis Plant, Stand Alone, 2.7 MGD (3,000 AFY)	each	\$ 15,800,000
Reverse Osmosis Plant, Stand Alone, 5.7 MGD (6,300 AFY)	each	\$ 23,000,000

<b>Description</b>	<b>Unit</b>	<b>Probable Cost per Unit</b>
Enlarge planned 2MGD SSLOCSD facility by 2.7 MGD	LS	\$ 12,000,000
Enlarge planned 2MGD SSLOCSD facility by 5.7 MGD	LS	\$ 18,000,000
Chloramination Facilities at existing NCSD wells	LS	\$ 1,100,000
Clorine Contact Treatment at Southland WWTP	each	\$ 2,319,000
Coag/Filt Plant, 2.7 MGD (1800 gpm) (3,000 AFY)	each	\$ 3,900,000
Coag/Filt Plant, 5.7 MGD (3900 gpm) (6,300 AFY)	each	\$ 7,800,000

**O&M Costs**

Electricity	kWh	\$ 0.13
Reverse Osmosis Plant, Stand Alone, 2.7 MGD (3,000 AFY)	acre-feet	\$ 1,200
Reverse Osmosis Plant, Stand Alone, 5.7 MGD (6,300 AFY)	acre-feet	\$ 1,100
Coagulation and Filtration Treatment Cost	acre-feet	\$ 200
Chloramination Treatment Costs	acre-feet	\$ 20

# Appendix B – Hydrogeology Constraints Analyses

SAIC, Inc., Technical Memoranda:

June 1, 2007, Yield of State Water Project water for Central Coast Water Authority and San Luis Obispo County

June 1, 2007, Yield of Aquifer Storage and Recovery

June 5, 2007, Santa Maria River Underflow





TO: Boyle Engineering Corporation  
RE: Yield of State Water Project water for CCWA and SLO  
DATE: May 22, 2007  
Page 2 of 2

1 The CCWA State Water Project Table A amount is 45,486 acre-feet per year (AFY). On a  
2 long-term average basis roughly 34,500 AFY of SWP water is available to the CCWA (Table 1).  
3 In a "wet" year about 43,500 acre-feet (AF) of SWP water is available and in a "dry" year about  
4 29,500 AF of SWP water is available to the CCWA (Table 1). There is a 50% probability that  
5 during any year available SWP water will exceed 38,000 AF (Figure 1).

6 **Yield of State Water Project for San Luis Obispo County (SLO)**

7 The SLO State Water Project Table A amount is 25,000 AFY. On a long-term average  
8 basis roughly 19,000 AFY of SWP water is available to SLO (Table 2). In a "wet" year about  
9 24,000 AF of SWP water is available and in a "dry" year about 16,500 AF of SWP water is  
10 available to SLO (Table 2). There is a 50% probability that during any year available SWP water  
11 will exceed 21,000 AF (Figure 2).

12 **METHODOLOGY**

13 The Table A amounts for the Central Coast Water Authority (45,486 AFY) and San Luis  
14 Obispo County (25,000 AFY) are based on the SWP Delivery Reliability Report (DWR, 2005).  
15 The hydrologic water year type classification is based on the California Department of Water  
16 Resources Sacramento Valley index (DWR, 2005). The simulated delivery as a percentage  
17 (Column 3 in Tables 1 and 2) for Water Year 1922 through Water Year 1994 is based on Table B-  
18 7 of the SWP Delivery Reliability Report (DWR, 2005). The simulated delivery in acre-feet  
19 (Column 4 in Tables 1 and 2) is computed by multiplying the simulated delivery as a percentage  
20 (Column 3 in Tables 1 and 2) with the Table A amount of 45,486 AFY for the CCWA and 25,000  
21 AFY for SLO. The long-term average delivery is the average of simulated deliveries (as a  
22 percentage) over the period from Water Year 1922 through Water Year 1994. The "dry" year  
23 and "wet" year delivery is the average of the deliveries made in each respective hydrologic year  
24 types. The probability distribution figures of SWP Delivery to CCWA and SLO are based on the  
25 simulated deliveries in acre-feet (Column 4 in Tables 1 and 2).

D  
R  
A  
F  
T

**Table 1. Estimated SWP Deliveries to CCWA (Water Years 1922-1994)**

Year of Simulation (Water Year)	Hydrologic Year Type	Simulated Delivery (% of Full Table A)	Simulated Delivery to CCWA (Acre-Feet)
1	2	3	4
1922	AN	98%	44,576
1923	BN	89%	40,483
1924	C	24%	10,917
1925	D	35%	15,920
1926	D	89%	31,385
1927	W	98%	44,576
1928	AN	79%	35,934
1929	C	28%	11,826
1930	D	68%	30,021
1931	C	28%	11,826
1932	D	45%	20,469
1933	C	48%	21,833
1934	C	38%	17,285
1935	BN	90%	40,937
1936	BN	89%	40,483
1937	BN	77%	35,024
1938	W	100%	45,486
1939	D	83%	37,753
1940	AN	96%	43,867
1941	W	99%	45,031
1942	W	100%	45,486
1943	W	87%	39,573
1944	D	84%	38,208
1945	BN	86%	39,118
1946	BN	92%	41,847
1947	D	63%	28,656
1948	BN	63%	28,656
1949	D	64%	29,111
1950	BN	70%	31,840
1951	AN	97%	44,121
1952	W	100%	45,486
1953	W	95%	43,212
1954	AN	93%	42,302
1955	D	43%	19,559
1956	W	100%	45,486
1957	AN	74%	33,660
1958	W	98%	44,576
1959	BN	84%	38,208
1960	D	49%	22,288
1961	D	68%	30,930
1962	BN	76%	34,569
1963	W	98%	44,576
1964	D	74%	33,660
1965	W	78%	35,479
1966	BN	93%	42,302
1967	W	98%	44,576
1968	BN	87%	39,573
1969	W	99%	45,031
1970	W	95%	43,212
1971	W	99%	45,031
1972	BN	66%	30,021
1973	AN	89%	40,483
1974	W	100%	45,486
1975	W	99%	45,031
1976	C	67%	30,476
1977	C	20%	9,097
1978	AN	95%	43,212
1979	BN	85%	38,663
1980	AN	84%	38,208
1981	D	82%	37,299
1982	W	100%	45,486
1983	W	100%	45,486
1984	W	99%	45,031
1985	D	80%	36,389
1986	W	73%	33,205
1987	D	69%	31,385
1988	C	24%	10,917
1989	D	70%	31,840
1990	C	28%	12,736
1991	C	24%	10,917
1992	C	28%	12,736
1993	AN	97%	44,121
1994	C	74%	33,660
<b>Long-term Average (1922-1994)</b>		<b>76%</b>	<b>34,488</b>
Sacramento Valley Water Year Hydrologic Classification:		Average Simulated Delivery for Year Type Water Years 1922 through 1994 (% of Full Table A)	Average Simulated Delivery for Year Type Water years 1922 through 1994 (Acre-feet)
W	Wet year type	96%	43,645
AN	Above normal year type	90%	41,028
BN	Below normal year type	82%	37,266
D	Dry year type	65%	29,680
C	Critical year type	36%	16,185

**Figure 1 - Probability of SWP Delivery - CCWA**

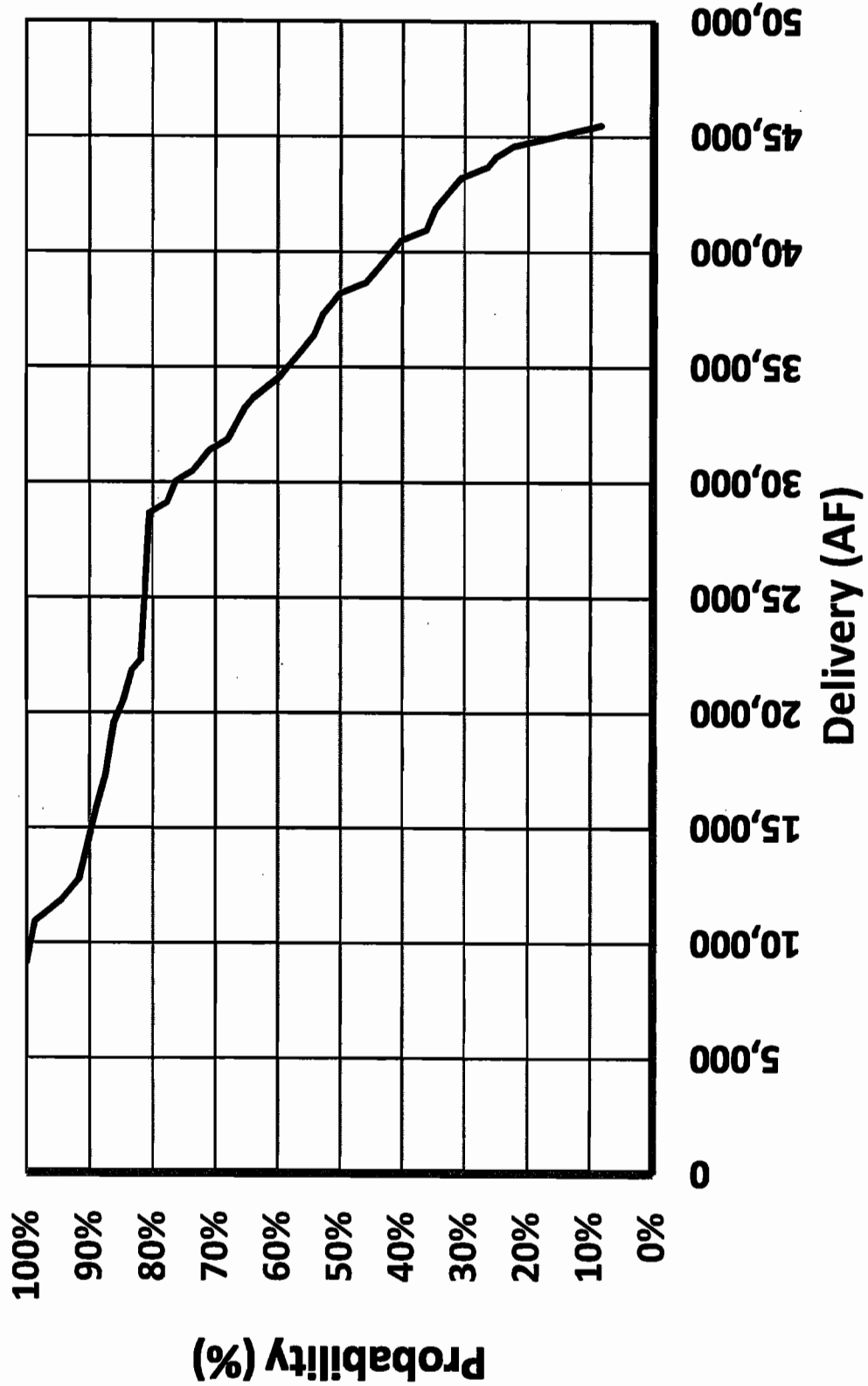

**Table 2. Estimated SWP Deliveries to SLO (Water Years 1922-1994)**

Year of Simulation (Water Year) 1	Hydrologic Year Type 2	Simulated Delivery (% of Full Table A) 3	Simulated Delivery to SLO (Acre-Feet) 4
1922	AN	98%	24,500
1923	BN	89%	22,250
1924	C	24%	6,000
1925	D	35%	8,750
1926	D	69%	17,250
1927	W	98%	24,500
1928	AN	79%	19,750
1929	C	26%	6,500
1930	D	66%	16,500
1931	C	26%	6,500
1932	D	45%	11,250
1933	C	48%	12,000
1934	C	38%	9,500
1935	BN	90%	22,500
1936	BN	89%	22,250
1937	BN	77%	19,250
1938	W	100%	25,000
1939	D	83%	20,750
1940	AN	96%	24,000
1941	W	99%	24,750
1942	W	100%	25,000
1943	W	87%	21,750
1944	D	84%	21,000
1945	BN	86%	21,500
1946	BN	92%	23,000
1947	D	83%	15,750
1948	BN	83%	15,750
1949	D	64%	16,000
1950	BN	70%	17,500
1951	AN	97%	24,250
1952	W	100%	25,000
1953	W	95%	23,750
1954	AN	93%	23,250
1955	D	43%	10,750
1956	W	100%	25,000
1957	AN	74%	18,500
1958	W	98%	24,500
1959	BN	84%	21,000
1960	D	49%	12,250
1961	D	68%	17,000
1962	BN	76%	19,000
1963	W	98%	24,500
1964	D	74%	18,500
1965	W	78%	19,500
1966	BN	93%	23,250
1967	W	98%	24,500
1968	BN	87%	21,750
1969	W	99%	24,750
1970	W	95%	23,750
1971	W	99%	24,750
1972	BN	66%	16,500
1973	AN	89%	22,250
1974	W	100%	25,000
1975	W	99%	24,750
1976	C	67%	16,750
1977	C	20%	5,000
1978	AN	95%	23,750
1979	BN	85%	21,250
1980	AN	84%	21,000
1981	D	82%	20,500
1982	W	100%	25,000
1983	W	100%	25,000
1984	W	99%	24,750
1985	D	80%	20,000
1986	W	73%	18,250
1987	D	69%	17,250
1988	C	24%	6,000
1989	D	70%	17,500
1990	C	28%	7,000
1991	C	24%	6,000
1992	C	28%	7,000
1993	AN	97%	24,250
1994	C	74%	18,500
<b>Long-term Average (1922-1994)</b>		<b>76%</b>	<b>18,955</b>
Sacramento Valley Water Year Hydrologic Classification:		Average Simulated Delivery for Year Type Water Years 1922 through 1994 (% of Full Table A)	Average Simulated Delivery for Year Type Water years 1922 through 1994 (Acre-feet)
W	Wet year type	96%	23,988
AN	Above normal year type	90%	22,550
BN	Below normal year type	82%	20,482
D	Dry year type	65%	16,313
C	Critical year type	36%	8,896

**Figure 2 - Probability of SWP Delivery - SLO**

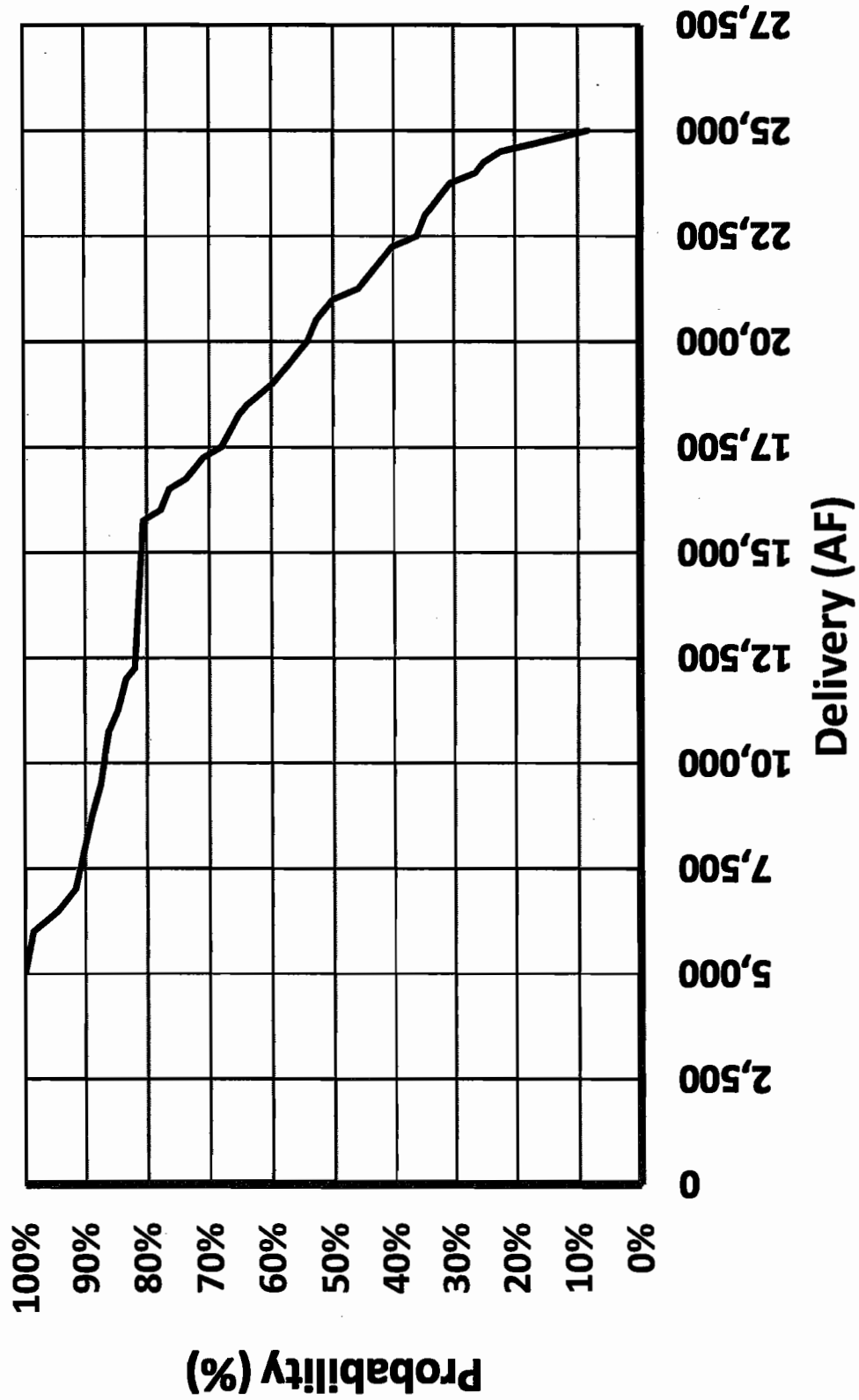



1 **TECHNICAL MEMORANDUM**

2 **TO:** Mike Nunely  
3  
4 **FROM:** Brad Newton

5 **RE:** Questions 12-17: Yield of Aquifer Storage and Recovery,  
6 SAIC Project Number: 01-0236-00-9785

7 **DATE:** June 1, 2007

8 **INTRODUCTION**

9 Programmatic development of an aquifer storage and recovery system requires an overall  
10 understanding of the local and regional hydrogeology. The District is currently investigating  
11 the opportunities to develop recharge basins on the Nipomo Mesa to augment the native supply  
12 of water to the principal production aquifer, typically the unconsolidated alluvial deposits of  
13 the Paso Robles Formation. Cause for concern over the lack of geologic understanding of the  
14 Nipomo Mesa is warranted, specifically in that recent sentinel monitoring well observations for  
15 sea water intrusion at the coast documented artesian conditions for all three well depths. These  
16 observations strongly suggest that a confining layer exists, however its depth, location and areal  
17 extent is not currently understood. Additionally, the presence of the Santa Maria River Fault  
18 has been interpreted to impede the lateral flow of groundwater, however the data reviewed  
19 during this investigation does not support nor deny this hypothesis.

20 On February 13, 2007, SAIC entered a contractual agreement with Boyle Engineering  
21 Corporation (Boyle) to provide hydrogeology services related to evaluating alternative water  
22 supplies to Nipomo Community Services District (the District). The District's Board requested  
23 an assessment of the yield of aquifer storage and recovery for the main production aquifer  
24 contained within the Nipomo Mesa Management Area (NMMA). Subsequently, Boyle  
25 requested SAIC address specific questions contained in a memorandum dated May 9, 2007.  
26 This technical memorandum constitutes a partial deliverable (Questions 12 - 17) to be included  
27 in Boyle's TM #1 Constraints Analysis to the District. Provided below and in the attachments  
28 herewith is a preliminary assessment of the plausibility of aquifer storage and recovery.

29 Several independent lines of evidence reviewed and interpreted herein support a  
30 proposed conceptual model of the hydrogeology within the NMMA. Groundwater surface  
31 elevations above ground surface at the sentinel monitoring well location on the beach support  
32 the geologic interpretation of a confining layer west of NMMA. Twitchell Reservoir water  
33 releases operational strategy to enhance groundwater recharge of the principal production  
34 aquifer supports the geologic interpretation of a confining layer that extends westward from the  
Bonita School Road crossing within the Santa Maria River corridor. The presence of Black Lake

*w:\boyle - ncsd (9785)\technical\yield of aquifer storage and recovery\2007-06-01 asr tech memo.doc*

---

SAIC Engineering, Inc. A Subsidiary of Science Applications International Corporation  
5464 Carpinteria Ave., Suite K • Carpinteria, CA 93013 • Telephone 805/566-6400 • Facsimile 805/566-6427

D  
R  
A  
F  
T

TO: Mike Nunely  
RE: Yield of Aquifer Storage and Recovery  
DATE: May 31, 2007  
Page 2 of 6

1 Canyon supports the interpretation that a confining layer exists from the coastal dunes to the  
2 east of the canyon head. Drilling logs and well casing records also support the presence of  
3 confining layer from the western area of municipal production to Omiya well where the  
4 confining layer abruptly thins. Additional drilling logs and casing records would be needed to  
5 strengthen the confidence of the presence and extent of a regional confining layer in the western  
6 half of the NMMA.

7 The proposed conceptual model of the hydrogeology within the NMMA is preliminary  
8 and may be changed upon reviewing additional data. For the purposes of this constraints  
9 analysis, and foregoing any additional data review, the proposed conceptual model provides  
10 the context for evaluating the following questions presented in the Boyle memorandum dated  
11 May 9, 2007.

12 **RESULTS**

13 12. How will the use of aquifer storage and recovery change the answers to the previous  
14 questions 1-5?

15 The available space of groundwater storage in the aquifer (approximately 400,000 acre-feet  
16 [AF]) is sufficient to accommodate the volume of water obtainable from the SWP to meet the  
17 District's target additional maximum supply of 6,300 acre-feet per year (AFY). Therefore,  
18 the answers to question 1-5 would not change.

19 13. How much water can be stored in the aquifer underlying the NMMA?

20 The aquifer underlying the NMMA has an estimated available storage of 400,000 AF above  
21 sea level. However, the proposed conceptual model of the hydrogeology constrains the  
22 available area for storage capacity to approximately one-quarter of the total 20,000 acres on  
23 NMMA as the target recharge area. This target area is bound by the confining layer to the  
24 west, the Black Lake Canyon to the north, the topographic boundary to the south, and the  
25 Santa Maria River Fault trace to the east, although little is known regarding lateral flow  
26 across the fault. The storage of 6,300 AF of water within 5,000 acres area would likely cause  
27 an increase in the groundwater surface elevation by approximately 10 feet over the 5,000  
28 acres.

29 14. Where are the best places to locate percolation/aquifer storage facilities?

30 The proposed preliminary target area is east of Omiya well, southwest of Santa Maria Fault,  
31 and north of the mesa topographic boundary. The ideal location of recharge ponds will be  
32 places with high percolation rates and no confining layer or low hydraulic conductivity  
33 zones at depth. The proposed preliminary target area is bound by the confining layer to the  
34 west, the Black Lake Canyon to the north, the topographic boundary to the south, and the  
35 Santa Maria River Fault trace to the east.

D  
R  
A  
F  
T

TO: Mike Nunely  
RE: Yield of Aquifer Storage and Recovery  
DATE: May 31, 2007  
Page 3 of 6

1 15. If percolation ponds are used, what area would be required?

2 Based on a typical percolation rate of 6 inches per day, approximately 50 acres of ponds  
3 would be required to recharge 6,300 AFY.

4 16. How many new wells would be needed to recapture the stored water?

5 Based on wells currently operated by the Nipomo Community Services District (NCSD) five  
6 extraction wells with a production rate of 800 gallons per minute (gpm) would be required  
7 to capture 6,300 AFY of water.

8 17. Where should these wells be installed (location and depth)?

9 We recommend locating the wells east of Highway 1, south of the Black Lake Canyon, west  
10 of Santa Maria River Fault, and north of the Woodlands development. This general area  
11 will distribute pumping across the NMMA providing for a more even access to the water  
12 resource. These wells should be screened in zones that produce large volumes of high  
13 quality water, likely within the Paso Robles Formation.

#### 14 **DISCUSSION**

15 The Paso Robles Formation is overlain by dune sands and younger alluvium, and overlies  
16 the Careaga Formation, an accumulation of unconsolidated to well-consolidated, shallow-water  
17 marine sands. The Paso Robles Formation is highly variable in color and texture, ranging from  
18 gavel and clay, sand and clay, gravel and sand, silt and clay. Most of it is fluvial in origin and  
19 in most places correlation between individual beds is not possible. The Careaga Formation is  
20 the lower most fresh water bearing formation and water quality is typically poor.

21 Identifying potential recharge sites on the Nipomo Mesa is contingent upon  
22 understanding the geology, the available land for recharge facilities construction, and the  
23 existing conveyance facilities or the need for new facility construction. The geologic conditions  
24 specific to recharge site identification on the Nipomo Mesa is poorly documented; however,  
25 anecdotal information, a few well logs, and existing reports have been reviewed and  
26 summarized herein to provide the basis for our current understanding. In general, recharge  
27 facilities are constructed over sediments where no confining layer exists in an effort to  
28 maximize percolation and therefore recharge to the groundwater aquifer. Set forth below is the  
29 summary of document reviews, geologic and topographic map evaluations, site visits, and well  
30 logs which indicates the likelihood of a confining layer and location of its inland margin.

31 Black Lake Canyon is an east-west trending topographic feature resulting from the erosion  
32 and transport of unconsolidated sand dune sediments westward to the active dune complex at  
33 the ocean. No river exists upstream of the canyon head, and the local surface drainage area at  
34 the canyon head is small. Surface water exists along much of the length in the canyon bottom  
35 and a terminal lake exists at the canyon mouth in the margin of the active beach dune complex.

D

R

A

F

T



TO: Mike Nunely  
RE: Yield of Aquifer Storage and Recovery  
DATE: May 31, 2007  
Page 4 of 6

1 No existing reports reviewed during this investigation explained the occurrence or physical  
2 processes that created the Black Lake Canyon. However, fine-grained layers in the upper  
3 portion of the Paso Robles Formation beneath dune sands are reported to function as a perching  
4 layer, and that some of the shallow groundwater that percolates downward within the  
5 permeable Nipomo Mesa dune sands is diverted laterally along these low-permeability layers  
6 and discharges into Black Lake Canyon and supports Black Lake and other systems of coastal  
7 drainages and lakes west of Nipomo Mesa (Papadopolas & Associates, 2004). While not  
8 specifically inferred in these reports, the laterally diverted perched shallow groundwater  
9 emerging at the ground surface can cause seepage erosion and over time develop a channel  
10 head which is likely to migrate up stream. This mechanism may explain the existence of Black  
11 Lake Canyon, and substantiate the occurrence of a confining layer above the principle  
12 production aquifer.

13 Santa Maria Valley Water Conservation District releases water stored in Twitchell  
14 Reservoir to enhance groundwater recharge by optimizing percolation to the principle  
15 production aquifer under the Santa Maria River. Reservoir water is released when there is no  
16 water flowing in the Sisquoc River as reported at the gage near Garey. Reservoir water is  
17 released at a steady flow rate, typically 300 cubic feet per second (cfs), to maximize  
18 groundwater recharge. This flow rate maintains a wetted reach up to but not beyond the Bonita  
19 School Road crossing. Anecdotal information suggests that a wetted reach beyond the crossing  
20 does not promote groundwater recharge to the principle aquifer because of the occurrence of  
21 confining layers at depth.

22 Drilling logs and well casing documentation may improve the understanding of the  
23 subsurface geology. The District provided this information for seven District production wells  
24 (Figure 1). Drilling logs were evaluated and correlations were made between well locations in  
25 order to identify the existence of a confining layer or sequence of layers. Well completion data  
26 documents the depth of the screened interval which is presumably located within the Paso  
27 Robles Formation (Table 1). General trends in the lithologies of each drilling log and the  
28 position of the screened interval were noted. The occurrence of a sequence of layers with a  
29 greater proportion of clay was identified and is interpreted as a confining sequence (Figure 2).  
30 The east-west transect of production well log data describes the presence of a confining layer  
31 directly above the screened interval in each well, however, the thickness of the confining  
32 sequence abruptly thins between the Omiya and Olympic wells. The occurrence of a thin clay  
33 layer at the Olympic well may indicate the eastern margin location of the regional confining  
34 layer that extends westerly to the ocean.

35 Drilling logs record the total drilling depth and a description of the lithology. All logs  
36 report that drilling ceased upon drilling into a blue clay lithology. This lithology is interpreted  
37 as the Franciscan Formation. Well casing is generally installed to total depth with the screened

D  
R  
A  
F  
T

TO: Mike Nunely  
RE: Yield of Aquifer Storage and Recovery  
DATE: May 31, 2007  
Page 5 of 6

1 interval at bottom, directly above the Franciscan Formation. The elevation of the top of the  
2 Franciscan Formation is 100 feet lower on the west side of the Oceano Fault relative to the east  
3 side (Figure 2). The Sundale well is more consistent with the geology west of the Oceano Fault  
4 than the geology on the east side of the fault. Reviewing additional drilling logs and casing  
5 records may improve the understanding of the vertical offset along the Oceano Fault.

6 The principle production aquifer under the NMMA has an estimated total storage  
7 capacity 500,000 AF of groundwater above sea level (DRW, 2002). Currently, generally 90,000  
8 AF (SAIC, 2007) of water is stored above sea level in the aquifer. Therefore, approximately  
9 400,000 AF of groundwater storage is available in the Nipomo Mesa groundwater basin. The  
10 district currently is interested in obtaining at most 6,300 AFY of supplemental water from an  
11 alternative water supply. Based on these estimates, there is sufficient available storage to  
12 accommodate the 6,300 AFY of supplemental water supply.

13 The Southland Wastewater Treatment Facility (WWTF) operated 3 recharge basins  
14 covering 2.8 acres during the period of 1988 to 1992. The aggregate percolation during this 5  
15 year period was 760 AFY (Lawrance, 1993). This is equivalent to 53.6 AFY per acre or 1.8 inches  
16 per day per acre. This includes rotation of the ponds between filling, percolating and drying.  
17 Typical long-term percolation rates are on the order of 6 inches per day. It is reasonable to  
18 expect effective percolation rates for a recharge facility to be less when considering pond  
19 rotations for drying and maintenance, typically 2 of 3 ponds are wet at any time.  
20 Approximately 50 acres of recharge ponds would be required in order to bank 6,300 AFY.  
21 However, this is programmatically less efficient than to firstly utilize the 6,300 AFY of water in  
22 direct deliveries, while reducing pumpage, then secondly, to recharge the un-deliverable water  
23 in percolation ponds.

24 The number of wells needed to capture this volume of water can be estimated from  
25 current production data. The three most productive wells operated by the NCSO are the  
26 Eureka Well, Sundale Well and the Via Choncha Well. The respective capacity of these wells is  
27 850 gpm, 1000 gpm and 700 gpm (Boyle 2002). Assuming an average capacity per well of 850  
28 gpm, it is expected that a properly install production well will produce 1370 AFY. This value  
29 takes into account normal well operations such as downtime and maintenance. It is assumed  
30 that similar pumping operations would be implemented. To capture 6,300 AFY of water would  
31 require approximately 5 wells.

32 Geologic features present in the basin will dictate the optimal locations for new  
33 extraction wells. The wells should be located seaward of the recharge areas with sufficient  
34 distance to allow for mixing and natural filtration of the recharged water. However, wells  
35 should be placed far enough away from the coast to avoid causing seawater intrusion. We  
36 recommend locating the wells in areas where little pumping currently exists, east of Highway 1,

D  
R  
A  
F  
T

TO: Mike Nunely  
RE: Yield of Aquifer Storage and Recovery  
DATE: May 31, 2007  
Page 6 of 6

1 south of the Black Lake Canyon, west of Santa Maria River Fault, and north of the Woodlands  
2 development. This general area will distribute pumping across the NMMA providing for a  
3 more even access to the water resource. These wells should be screened in zones that produce  
4 large volumes of high quality water, likely within the Paso Robles Formation.

5

6 **REFERENCES:**

7 Boyle Engineering Corporation, (Boyle, 2002), Water and Sewer System Master Plan 2001,  
8 prepared for Nipomo Community Services District, update, March 2002.

9 Department of Water Resources, (DWR, 2002), Water Resources of the Arroyo Grande -  
10 Nipomo Mesa Area, 2002.

11 Lawrance, Fisk & McFarland, INC., (Lawrance, 1993), Engineering Considerations of  
12 Groundwater Yields and Rights on the Nipomo Mesa Sub-Area, San Luis Obispo,  
13 California, October 20, 1993.

14 Science Application International Corporation, (SAIC, 2007), Technical Memorandum #4  
15 Update to Groundwater in Storage NMMA, May 23, 2007.

16 S.S. Papadopoulos & Associates, INC., (Papadopoulos et al. 2004), Nipomo Mesa Groundwater  
17 Resources Capacity Study, San Luis Obispo County, California, prepared for the County of  
18 San Luis Obispo, 2004.

D

R

A

F

T



**FIGURE 1**  
**NMMA Hydrogeologic Features**  
**and NCSW Well Locations**

CREATED BY: JSD

REVISION 1: 5/2007

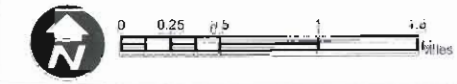

- Highways
  - NMMA
  - T-R Sections
  - Faults
  - NCSW Well Logs
  - Coastal Monitoring Wells
  - Margin of Confining Layer
- Aerial Photo - NAIP 2006

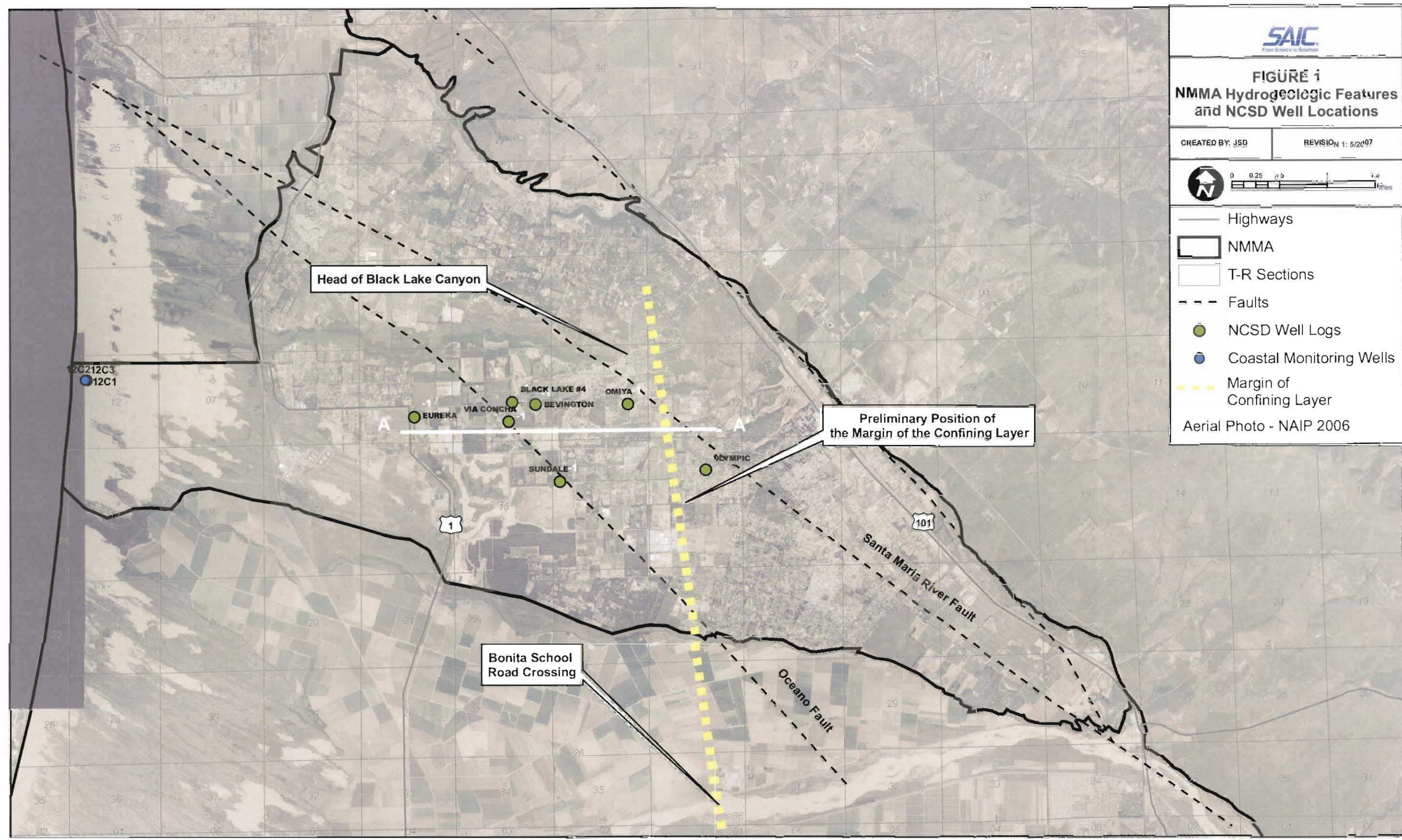

## Well Completion Table

### Nipomo Mesa Management Area

Well ID	Latitude	Longitude	Ground Surface Elevation (ft msl)	Total Depth (ft msl)	Screen (ft msl)		Screen Interval (ft)	Comments		
					Top	Bottom		Confining Layer (ft msl)	Confining Layer Interval (ft)	
Eureka 11N35W09K05	35° 02' 44.20"	120° 34' 04.93"	174	-546	-46	-401	355	31	-71	102
Via Concha 11N35W10L01S	35° 02' 40.61"	120° 33' 02.26"	264	-464	-126	-426	300	-4	-54	50
Sundale 11N35W15H01S	35° 02' 07.01"	120° 32' 29.11"	251	-459	-129	-329	200	-19	-119	100
Black Lake #4	35° 02' 51.19"	120° 32' 59.53"	301	-299	-379	-419	40	207	111	96
Bevington #2 11N35W10J02S	35° 02' 49.57"	120° 32' 43.93"	317	-329	-13	-253	240	47	-93	140
Omiya #2 11N35W11J02S	35° 02' 11.17"	120° 30' 52.05"	390	-260	0	-75	75	255	10	245
Olympic 11N35W13G01S	35° 02' 48.30"	120° 31' 42.57"	346	-129	-19	-109	90	46	28	18

**Notes:**

Information based on review of driller logs provided by NCSD

# Hydrogeology of Nipomo Mesa Mangement Area Conceptual Model

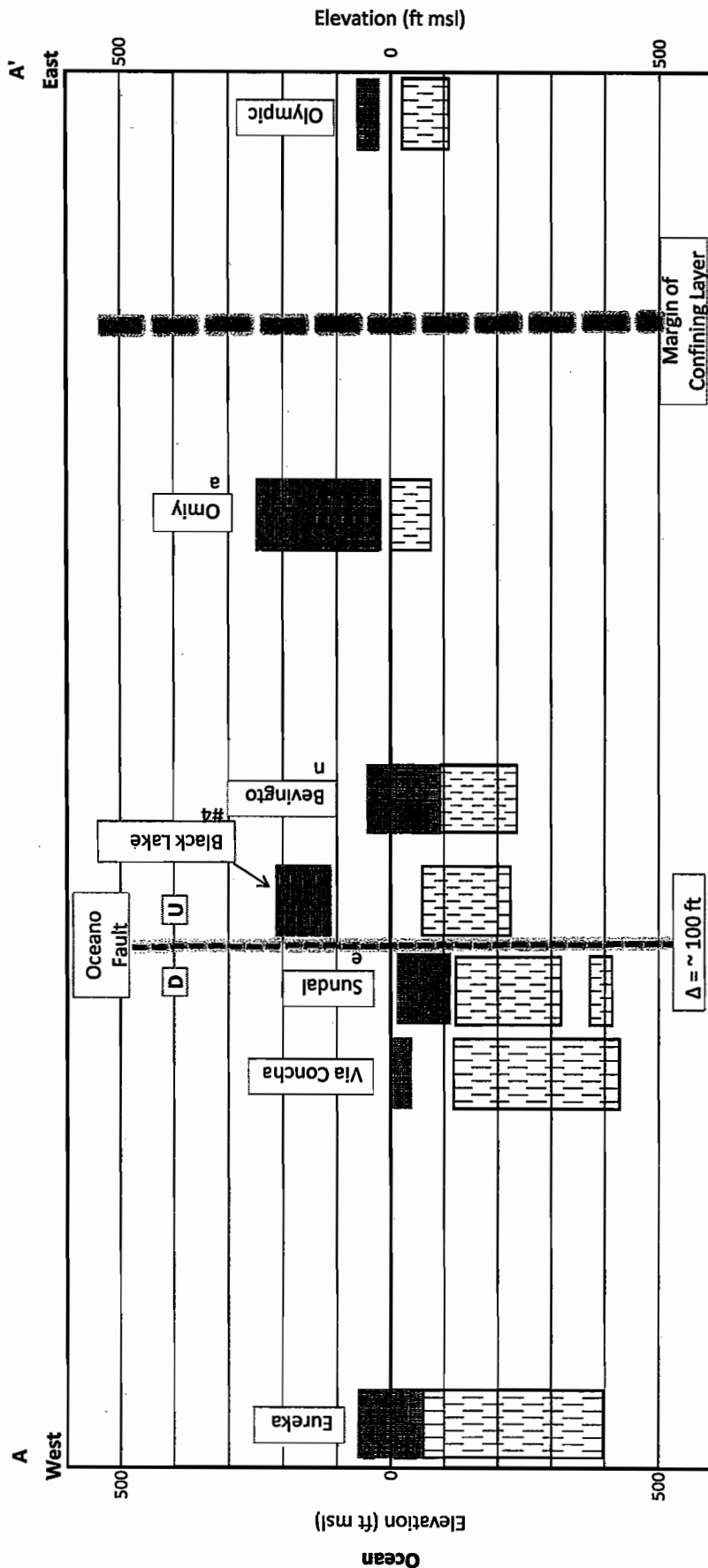

Confining Layer Dominate Clay (ft msl)

Screened Interval (ft msl)

Note:

All well data is projected to line (Figure 1)

 SAIC From Science to Solutions	FIGURE 2 DRAFT
--	-------------------



**TECHNICAL MEMORANDUM**

1  
2  
3  
4  
5  
6  
7  
8  
9  
10  
11  
12  
13  
14  
15  
16  
17  
18  
19  
20  
21  
22  
23  
24  
25  
26  
27  
28  
29  
30  
31

**TO:** Mike Nunley  
**FROM:** Nivan Bhuta, Brad Newton  
**RE:** Response to Boyle Engineering Questions 6-11 - Santa Maria River Underflow  
SAIC Project Number: 01-0236-00-9785  
**DATE:** June 5, 2007

**INTRODUCTION**

On February 13, 2007, SAIC entered a contractual agreement with Boyle Engineering Corporation (Boyle) to provide hydrogeologic services related to evaluating alternative water supplies to Nipomo Community Services District (the District). The District's Board requested an assessment of the Santa Maria River underflow as an alternative water supply. Subsequently, Boyle requested SAIC address specific questions contained in a memorandum dated May 9, 2007. Provided below is a preliminary assessment of Santa Maria River underflow and Santa Maria groundwater basin characteristics.

**FINDINGS**

Santa Maria River underflow recharges the Santa Maria groundwater basin. The Santa Maria groundwater basin is currently undergoing adjudication. The District must enter into an agreement with the parties entitled to receive water from the Santa Maria groundwater basin in order to obtain additional water supply from Santa Maria River underflow.

**RESULTS**

6. What are the typical depths to groundwater and the range of depths observed in the relevant record?

Data showing the depth to groundwater and range of depths to groundwater are not available for Santa Maria River underflow. The average depth to groundwater for the entire basin is 281 feet (ft) with a range of 16 ft to 1,220 ft based on domestic wells (DWR, 2002).

7. What is the quantity of water available?

The quantity of Santa Maria River underflow is not known. Estimates of annual streamflow loss for the Santa Maria River are provided in question number 10. As indicated in the Santa Maria Groundwater Adjudication the native yield of the entire Santa Maria groundwater basin was estimated by GEOSCIENCE to be 60,000 acre-feet per year (AFY) before implementation of the Twitchell Reservoir Project in 1960. This estimate of native yield

D  
R  
A  
F  
T

w:\boyle - ncsd (9785)\technical\river underflow\2007-06-05 santa maria river underflow tech memo draft.doc

1 includes 47,300 AFY of streamflow loss, 12,500 AFY of recharge from rainfall and 200 AFY of  
2 subsurface inflow to the Santa Maria groundwater basin.

3 8. What is the quality of water available?

4 Water quality data for Santa Maria River underflow is not available. For the entire Santa  
5 Maria groundwater basin TDS concentrations increase toward the center of the basin beneath  
6 the cities of Santa Maria and Orcutt and away from the recharge area of the Santa Maria River  
7 (SBCWA 1999; 2001). Nitrate concentrations as high as 240 milligrams per liter (mg/L) have  
8 been recorded and some wells sampled from 1990 through 2000 show nitrate concentrations  
9 that exceed the minimum contaminant level (DWR, 2002).

10 9. What is the reliability of this water supply?

11 While the estimate of native yield for the entire Santa Maria groundwater basin is 60,000  
12 AFY, the volume in storage is on the order of ten times the native yield, therefore providing a  
13 reasonable reliability to the annual supply for any one year. The confidence in this reliability  
14 estimate is predicated on the understanding that over long periods, annual rainfall totals are  
15 occasionally extremely high and therefore the likelihood of replacing groundwater pumpage in  
16 excess of the native yield is high.

17 Winter floodwaters are captured at Twitchell Reservoir annually. Based on USGS gage  
18 data (for Water Years 1960 through 1983) releases from Twitchell Reservoir have been made in  
19 all but three years since the implementation of the project in 1960. Therefore, Santa Maria River  
20 underflow provides a reasonable reliability to the annual supply for any one year.

21 10. What is a reasonable estimate of its yield?

22 The estimated annual streamflow loss for the Santa Maria River downstream of the  
23 confluence with the Sisquoc River Valley is 60,000 AFY since the implementation of the  
24 Twitchell Reservoir Project (Scalmanini, 1997). The estimated yield of the Twitchell Reservoir  
25 Project is 35,000 AFY as indicated in the Santa Maria Groundwater Adjudication. The Santa  
26 Maria Groundwater Adjudication litigation has concluded, but the court has not rendered a  
27 final decision. So, the numbers presented above are still preliminary.

28 11. What physical connections exist between this water source and other nearby sources  
29 that may already be "spoken for"? (i.e., Who else has a reasonable chance of  
30 establishing a prior claim to this water?)

31 Subsurface outflow to the west from the Santa Maria Valley enters the ocean and  
32 outflow to the northwest enters the Nipomo Mesa Management Area (NMMA). Cause for  
33 concern over changing the subsurface flow dynamics due to an additional pumpage of the  
34 Santa Maria River underflow is warranted, specifically in that the current underflow to the  
35 NMMA has been historically accounted for in the water supply estimates for the District.

D  
R  
A  
F  
T



TO: Mike Nunley  
RE: Response to Boyle Engineering Questions 6-11 - Santa Maria River Underflow  
DATE: June 5, 2007  
Page 3 of 4

1 **METHODOLOGY**

2 The answers to the questions posed in the results section are based upon a review of  
3 existing documentation related to the Santa Maria groundwater basin and to the Santa Maria  
4 Groundwater Adjudication. Provided below is additional analysis and discussion of the  
5 questions presented in the results section.

6 **DISCUSSION**

7 The Twitchell Reservoir Project was implemented in 1960 to regulate surface water  
8 releases to the Santa Maria River system upstream of the confining layer in order to optimize  
9 groundwater recharge to the Santa Maria groundwater basin (Scalmanini, 1997). The Santa  
10 Maria Groundwater Adjudication indicates that only Santa Maria Valley parties have paid for,  
11 managed and benefited from the Twitchell Reservoir Project. The District would need to  
12 purchase a water right from the parties involved in the Twitchell Reservoir Project or make an  
13 agreement with parties entitled to water from the Santa Maria groundwater basin in order to  
14 access Santa Maria River underflow as an alternative water supply.

15 6. The depth to groundwater information provided is based on data for the Santa Maria  
16 groundwater basin as a whole, including the Northern Cities, the Nipomo Mesa Management  
17 Area and the Santa Maria Valley. Data must be collected and analyzed from wells along the  
18 Santa Maria River in order to provide a range of depths to groundwater in the vicinity of the  
19 Santa Maria River.

20 7. The quantity of water available (60,000 AFY) presented is for the entire Santa Maria  
21 groundwater basin. Previous reports and studies of the Santa Maria groundwater basin have  
22 shown varied estimates of native yield. The Santa Maria Groundwater Adjudication litigation  
23 has concluded, but the court has not rendered a final decision. So, the estimated native yield for  
24 the entire Santa Maria groundwater basin of 60,000 AFY is still preliminary.

25 The estimated annual streamflow loss for the Santa Maria River downstream of the  
26 confluence with the Sisquoc River Valley was 26,000 AFY (for Water Years 1942 through 1959)  
27 prior to the Twitchell Reservoir Project and 60,000 AFY (for Water Years 1960 through 1983)  
28 after implementation of the Twitchell Reservoir Project (Scalmanini, 1997).

29 8. The groundwater quality data provided is based on data for the Santa Maria  
30 groundwater basin as a whole. Water quality data of Santa Maria River flows and groundwater  
31 in the vicinity of the Santa Maria River must be collected and analyzed in order to provide  
32 water quality data for the Santa Maria River underflow.

33 9. The average annual release from Twitchell Reservoir is 39,000 AFY based on USGS  
34 gage data (for Water Years 1960 through 1983). Releases have been made in all years since the  
35 implementation of the Twitchell Reservoir Project except Water Years 1972, 1976 and 1977.

D  
R  
A  
F  
T

TO: Mike Nunley  
RE: Response to Boyle Engineering Questions 6-11 - Santa Maria River Underflow  
DATE: June 5, 2007  
Page 4 of 4

1 10. If all releases from Twitchell Reservoir recharged the Santa Maria groundwater  
2 basin, then Santa Maria River underflow would yield approximately 65,000 AFY (26,000 AFY  
3 streamflow losses prior to Twitchell Reservoir + 39,000 AFY release from Twitchell Reservoir).

4 11. Geologically the quaternary alluvium that comprises the principal aquifer is  
5 composed of an upper fine-grained member consisting of sand and gravel and a lower coarse  
6 grained member consisting of boulders and gravel throughout the valley. The upper member  
7 toward the Pacific Ocean is much finer grained and consists of predominately silt and clay.  
8 This finer grained upper member (confining layer) confines groundwater to the lower member  
9 in areas westward of Santa Maria's water treatment plant. Water flowing in the segment of the  
10 Santa Maria River above the confining layer does not recharge into the groundwater basin and  
11 wastes to the Ocean (Wort, 1951). The Twitchell Reservoir Project was implemented to regulate  
12 flows along the lower reaches of the Cuyama River in order to minimize water waste to the  
13 Ocean.

D  
R  
A  
F  
T

## Appendix C – CCAMP Data for Oso Flaco Watershed

This summary of water quality in Oso Flaco Lake and Oso Flaco Creek is based on the following studies and documents:

- Cachuma Resource Conservation District and the Dunes Center. *Draft Nitrate and Sediment Assessment, Oso Flaco Watershed, San Luis Obispo County, California, August 2004*. Report prepared for California Regional Water Quality Control Board, Central Coast Region.
- Central Coast Ambient Monitoring Program (CCAMP). *312 Santa Maria River Hydrologic Unit Draft Report for Sampling Year 2000*

CCAMP water quality data is summarized below for monitoring sites in the Oso Flaco Creek watershed. Maximum Contaminant Levels (MCLs) and Secondary MCLs are also listed for comparison.

Note that water quality standards shown below for municipal supply are in some cases based on source water quality and in other cases based on distribution system water quality. Surface water treatment must meet "performance standards", and the MCL is deemed to be a "treatment technique". For example, the performance standard for turbidity is 0.3 NTU, and the treatment technique to achieve this would be conventional treatment; however, if an alternative filtration technology is used as the treatment technique, the turbidity performance standard is typically 0.1 NTU.

**Table C-1 Water Quality and Maximum Contaminant Levels (MCLs)**

Primary Constituent	CDHS MCL	USEPA MCL	Oso Flaco Lake @ culvert (Site 312 OFL)			Oso Flaco Creek @ Oso Flaco Lake Road (Site 312OFC)			Little Oso Flaco Creek (Site 312 OFN)		
			Max	Min	Mean	Max	Min	Mean	Max	Min	Mean
Coliforms, Fecal MPN/100mL	See Note 1		1,300	20	244	35,000	1	3,586	24,000	1	2,314
Coliforms, Total, MPN/100mL			7,000	300	2,437	190,000	199	61,425	127,000	800	21,653
Nitrate as Nitrogen, mg/L		10	37.1	28	31.4	70.2	23.8	37.1	48.8	26.5	34.5
Nitrate(as NO3), mg/L	45		165	125	140	312	106	165	217	118	154
Nitrite as Nitrogen, mg/L	1	1	0.42	0.005	0.106	0.54	0.005	0.118	0.144	0.005	0.06
Nitrogen, Total, mg/L	10		37.1	28	31.3	134	26	49	45.1	26.5	32.2

Note 1: The level of pathogenic organisms present in a surface water sources will establish the degree of treatment required, as defined by the USEPA in the Surface Water Treatment Rule guidance and the Long Term 2 Enhanced Surface Water Treatment Rule.

"empty cell " means not reported / no analysis for this constituent

mg/L = milligrams per liter of sample collected = ppm

ppm = parts per million

MPN/100mL = most probable number per 100 milliliters of sample collected

**Table C-2 Water Quality and Secondary Standards**

Secondary Constituent	Consumer Acceptance Contaminant Levels		Oso Flaco Lake @ culvert (Site 312 OFL)			Oso Flaco Creek @ Oso Flaco Lake Road (Site 312OFC)			Little Oso Flaco Creek (Site 312 OFN)		
	CDHS	USEPA	Max	Min	Mean	Max	Min	Mean	Max	Min	Mean
Chloride, mg/L	250	250	133	82	99	247	43	95	110	60	92
Conductivity, umhos/cm	900		2,763	1,830	2,128	2,820	1,595	2,010	2,350	1,680	2,007
Lab Turbidity (NTU)	5		34.5	1	9.8	526	4	190	85.1	2.1	17.3
Sulfate mg/L	250	250	740	640	678	950	440	656	730	568	633
Total Dissolved Solids, mg/L	500	500	2,040	338	1,470	2,100	387	1,445	2,080	969	1,576
Turbidity, NTU (See Note 1.)	5		34.5	1	9.8	526	4	190	85.1	2.1	17.3

Note 1: Acceptable turbidity levels for treated surface water are based on the treatment technique used, typically 0.1 to 0.3 NTU. There are no established limits for turbidity in raw surface water prior to treatment.

"empty cell " means not reported / no analysis for this constituent

mg/L = milligrams per liter of sample collected = ppm

NTU = Nephelometric Turbidity Units

ppm = parts per million

umhos/cm = millisiemens per centimeter

Additional parameters were measured under the CCAMP program for which water quality MCLs and Secondary Standards do not exist. In some cases these measured parameters indicate the presence of a water-borne contaminant. These results are summarized below:

**Table C-3 Sediment Inorganic Chemistry**

Inorganic Constituent in Sediment <sup>2</sup>	Little Oso Flaco Creek (Site 312 OFN)
Antimony in Sediment (mg/kg) <sup>2</sup>	1.50
Arsenic in sediment (mg/kg) <sup>2</sup>	15
Barium, in sediment (mg/kg) <sup>2</sup>	160
Beryllium in sediment (mg/kg) <sup>2</sup>	2.70
Cadmium in sediment (mg/kg) <sup>2</sup>	0.10
Chromium in sediment (mg/kg) <sup>2</sup>	40.00
Copper in sediment (mg/kg) <sup>2</sup>	33
Lead in sediment (mg/kg) <sup>2</sup>	20
Mercury in sediment (mg/kg) <sup>2</sup>	0.037
Nickel in sediment (mg/kg) <sup>2</sup>	35
Selenium in sediment (mg/kg) <sup>2</sup>	4
Thallium in sediment (mg/kg) <sup>2</sup>	1.00
Vanadium in sediment (mg/kg) <sup>2</sup>	78
Zinc in sediment (mg/kg) <sup>2</sup>	110

MCL In Water	
CDHS <sup>1</sup>	USEPA <sup>1</sup>
0.006 ppm	0.006 ppm
0.05 ppm	0.010 ppm
1 ppm	2 ppm
0.004 ppm	0.004 ppm
0.005 ppm	0.005 ppm
0.05 ppm	
1.3 ppm	
0.015 ppm	
2 ppb	2 ppb
0.1 ppm	
0.05 ppm	0.05 ppm
0.002 ppm	0.002 ppm
5 ppm	5 ppm

"empty cell " means not reported / no analysis for this constituent

1 MCL applies to constituents dissolved in water

2 MCL does not apply to constituents bound to fine-grained sediment samples collected within the wetted creek channel or the tissue of fish

**Table C-4 Sediment Organic Chemistry**

Organic chemicals detected in the sediment sample collected at Little Oso Flaco Creek (312OFN) in June 2000. Available criteria are shown for reference. Units of measurement are ppb (ug/kg). ND is non-detect. Criteria exceedances are bold. (CCAMP, 2002, from Table 5.1.5c.)

Site Tag	DDD(p,p')	DDE(p,p')	DDT, Total	Dieldrin	Endrin	Chlorpyrifos	Total PCB
312OFN <sup>2000</sup>	1.0	5.3	9.3	2.6	1.4	ND	ND
PEL (freshwater)	<b>8.51</b>	<b>6.75</b>	<b>4450</b>	<b>6.67</b>	<b>62.4</b>		<b>277</b>

PEL (probable effect level)

**Table C-5 Metals in Fish Tissue**

Site specific assessment of data used to assess impairment of aquatic life uses in the Santa Maria River Hydrologic Unit (HU312). **Yes** - evidence that a problem exists, **No** - no evidence that a problem exists. (CCAMP, 2002, from Table 5.1.5a.)

Constituent	Arsenic	Chromium	Copper	Lead	Mercury	Selenium	Zinc
<b>Water Contact Recreation Assessment Threshold</b>	1.5	1	20	2	0.5	2	45
<b>Median International Standards (MIS)</b>	1.0	1.0	20.0	2.0	0.5	0.3	70
<b>California's Office of Environmental Health Hazard Assessment (OEHHA)</b>	1.0				0.3	2.0	
<b>Units</b>	ppm	ppm	ppm	ppm	ppb	ppb	ppm
<b>Matrix</b>	Tis	Tis	Tis	Tis	Tis	Tis	Tis
<b>Sites</b>							
<b>312OFL</b>	<b>No</b>	<b>No</b>	<b>No</b>	<b>No</b>	<b>No</b>	<b>No</b>	<b>No</b>

**Table C-6 Organic Compounds in Fish Tissue**

Organic chemical concentrations in whole fish from Oso Flaco Lake (ng/g or ppb). National Academy of Sciences (NAS) and Food and Drug Administration (FDA) criteria for freshwater fish are shown as exceedances threshold values. Exceedances are **bold**. (CCAMP, 2002, from Table 5.1.4d.)

Site	Date	Aldrin	Chlordane	Total DDT	Dieldrin	Endrin	Heptachlor	Tot PCB	TOXAP
Oso Flaco Lake	Filet		2.2	<b>345.1</b>	<b>25.5</b>	10.5	< 2.0	NA	<b>243.0</b>
NAS <sup>1</sup>	Whole Fish	100	100	1000	100	100	100	500	100
FDA <sup>2</sup>	Filet	300	300	5000	300	300	300	2000	5000
OEHHA <sup>3</sup>	Filet		30	100	2	1000	4	20	30

Notes:

- (1) National Academy of Sciences guidelines
- (2) U.S Food and Drug Administration Action Levels
- (3) California's Office of Environmental Health Hazard Assessment (OEHHA) fish tissue criteria

### Table C-7 Toxicity Data

Percent survival of *C. dubia* and *H. azteca* in toxicity tests conducted in the Santa Maria Hydrologic Unit July 2002 through May 2003. Bold numbers indicate survival is significantly different from the control value @ p<0.05. NA=not analyzed. (CCAMP, 2002, Table 5.1.5b. ) This sample contained chlorpyrifos levels that are known to exceed acute toxicity threshold for *C. dubia*.

Site	<i>C. dubia</i> survival Jul-02	<i>C. dubia</i> survival Sept-02	<i>C. dubia</i> survival Mar-02	<i>C. dubia</i> survival May-02	<i>H. azteca</i> survival June-02	<i>H. azteca</i> survival May-03
312OFC	80	100	100	<b>30</b>	<b>71</b>	N/A

### *Tissue Bioaccumulation*

Resident fish tissue samples (from Oso Flaco Lake) did not have any metal concentrations which exceeded published Median International or OEHHA Standards.

# Appendix D – Environmental and Permitting Constraints Analysis

Padre Associates, Inc., May 25, 2007.



---

**NIPOMO COMMUNITY SERVICES DISTRICT**

**SUPPLEMENTAL WATER ALTERNATIVES  
ENVIRONMENTAL AND PERMITTING CONSTRAINTS  
ANALYSIS**

**Prepared By:**

Padre Associates, Inc.  
811 El Capitan Way, Suite 130  
San Luis Obispo, Ca 93401  
(805) 786-2650

**Prepared For:**

Nipomo Community Services District  
Boyle Engineering Corporation

May 25, 2007

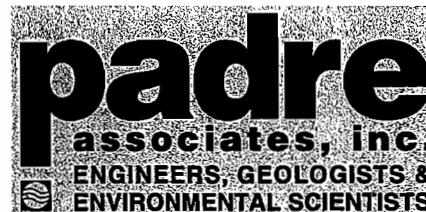



## TABLE OF CONTENTS

	<u>Page</u>
<b>1.0 INTRODUCTION.....</b>	<b>1</b>
1.1 SCOPE OF SERVICES.....	1
1.2 DESCRIPTION OF ALTERNATIVES.....	1
<b>2.0 PERMITTING REQUIREMENTS.....</b>	<b>4</b>
2.1 FEDERAL AGENCIES .....	4
2.2 STATE AGENCIES .....	5
2.3 LOCAL AGENCIES .....	7
2.4 CALIFORNIA ENVIRONMENTAL QUALITY ACT .....	7
<b>3.0 ENVIRONMENTAL CONSTRAINTS .....</b>	<b>9</b>
3.1 BIOLOGICAL RESOURCES .....	9
3.1.1 FEDERALLY-LISTED ANIMAL SPECIES.....	9
3.1.2 SPECIAL-STATUS PLANTS.....	10
3.1.3 OTHER POTENTIALLY OCCURRING SPECIAL-STATUS SPECIES .....	11
3.2 WETLANDS/WATERS OF THE U.S.....	13
3.3 CULTURAL RESOURCES .....	14
3.4 GEOLOGY AND SOILS.....	15
3.5 HYDROLOGY AND WATER QUALITY .....	15
<b>4.0 SUMMARY AND RECOMMENDATIONS .....</b>	<b>16</b>
4.1 SUMMARY OF ENVIRONMENTAL/PERMITTING ISSUES BY ALTERNATIVE .....	16
4.2 GENERAL RECOMMENDATIONS .....	19
<b>5.0 REFERENCES.....</b>	<b>23</b>

### LIST OF TABLES

Table 1. Permit Requirements Summary .....	8
Table 2. Matrix of Required Permits by Alternative .....	21

### LIST OF FIGURES

- Figure 1 – Project Alternatives Location Map
- Figure 2 – Recorded Occurrences of Special-Status Species – Conoco Phillips Refinery Site



Figure 3 – Recorded Occurrences of Special-Status Species – Oso Flaco Lake Area

Figure 4 - Recorded Occurrences of Special-Status Species – Hutton Road Area

Figure 5 - Recorded Occurrences of Special-Status Species – Wastewater Disposal Alternative



## 1.0 INTRODUCTION

At the request of Boyle Engineering Corporation (Boyle), Padre Associates, Inc. (Padre) has prepared this environmental and permitting constraints analysis for supplemental water supply alternatives under consideration by the Nipomo Community Services District (NCSD). The following provides an overview of the primary environmental constraints and permitting issues associated with the six supplemental water supply alternatives under consideration by the NCSD.

### 1.1 SCOPE OF SERVICES

Padre's scope of services included the following tasks:

- Collection and analysis of existing environmental data for the water supply options;
- Preparation of a constraints analysis identifying potential environmental impacts associated with each of the water supply options;
- Identification of permitting requirements for each alternatives;
- Preparation of a permitting requirements matrix which presents a list of resource surveys and other pertinent environmental information that would be required by permitting and regulatory agencies.
- Preparation of this report presenting Padre's findings regarding the environmental and permitting constraints for the supplemental water alternatives under consideration.

This report is divided into five sections: Section 1 introduces the supplemental water supply alternatives. Section 2 provides a discussion of the federal, state, and local agencies that would be involved in permitting any of the alternatives and types of anticipated permits needed. Section 3 presents an overview of environmental resources that may be affected by the alternative projects and potential constraints to constructing the alternative projects. Section 4 provides a summary of salient points and Padre's recommendations. Section 5 presents the references cited in the report.

### 1.2 DESCRIPTION OF ALTERNATIVES

Presented below are descriptions of each of the water supply alternatives discussed in this report. Refer to Figure 1 for the relative locations of the proposed features of each alternative.

#### **Alternative No. 1 (Sea Water/Cooling Water):**

This alternative would include a water treatment facility located at either the ConocoPhillips (COP) Santa Maria Refinery using process cooling water as a water source, desalination of sea water at another location owned and operated by NCSD, or at the South San Luis Obispo County Sanitation District (SSLOCSD) Wastewater Treatment Facility located in Oceano.

**Alternative No. 2 (Oso Flaco Lake Wells):** This alternative would involve treating shallow groundwater or agricultural runoff at Oso Flaco Lake and delivering the treated water to the NCSD distribution system. This alternative may include extraction of either shallow ground

water, or surface runoff from agricultural lands into Oso Flaco Lake could be used as a water supply. The NCS D would build a new ocean outfall for the brine. In addition, enough water would be treated so that "cleaner" water would be released into the watershed to improve the health of the Oso Flaco wetlands.

**Alternative No. 3 (Water Trading with CCWA Agencies):** The State Water Project is a complex system of dams, reservoirs, power and pumping plants, canals, and aqueducts built to convey water from Lake Oroville to the Sacramento Delta, then on to Central and Southern California. The Coastal Branch of the State Water Project consists of (1) water conveyance facilities built by the California Department of Water Resources and (2) regional distribution and treatment facilities constructed by a cooperative group of local water agencies and cities operating as the Central Coast Water Authority (CCWA). Coastal Branch Phase II of the State Water Project was built between 1993 and 1997 to bring State water to San Luis Obispo and Santa Barbara Counties as per the Water Supply Contracts entered into by the State and both counties.

This alternative would consider acquiring unused capacity in the State Water Project (SWP) from one or more CCWA project participants, including acquiring exchange water from one or more CCWA project participants including Golden State Water Company. Water could be provided via a turnout along the State Water Pipeline within the NCS D boundary. This water would then either be delivered directly to the NCS D water system via pipeline from the Tefft Street turn-out, at a Bonita Well turnout, or indirectly via aquifer storage and recovery. As an option, NCS D could buy water directly from the CCWA or utilize aquifer storage and recovery for use of CCWA water for seasonal water needs.

**Alternative No. 4 (Santa Maria Valley Groundwater):** The City of Santa Maria may be willing to sell some of their entitlement to underflow water to NCS D. Facilities required to utilize this resource would include a wellfield, possibly treatment (based on regulatory review), pumping, storage, and a connection from the proposed wellfield to the District distribution system. It is assumed collector wells would be located along the Santa Maria River, near the end of Hutton Road or at the Bonita Well site.

**Alternative No. 5 (Groundwater Recharge from Southland Wastewater Treatment Facility):** This alternative would develop a groundwater recharge program within the Nipomo Mesa Management Area (NMMA) involving recharge of the groundwater basin with recycled water from Southland Wastewater Treatment Facility (WWTF). The NCS D owns and operates the Southland Wastewater Treatment Facility (WWTF), located just west of Highway 101 in the southern portion of Nipomo. It is anticipated recycled water could be pumped to the proposed recharge facilities during certain periods of the year. It is understood that the NCS D proposes to locate the proposed recharge facilities within the vicinity of the local groundwater pumping depression identified in previous studies of the Nipomo mesa groundwater basin. As an option under this alternative, NCS D could exchange water rights with Black Lake Golf Course, Black Lake development landscaping, and the Woodlands Golf Course and utilize treated wastewater for irrigation water at these areas.

The proposed groundwater recharge of recycled water within the study limits would not introduce a new supplemental water source from outside the NMMA, however, it would be

intended to provide a means to manage and help stabilize the groundwater basin within the subject area. As proposed, this alternative is intended to function as a groundwater management program and not a true supplemental water alternative.

**Alternative No. 6 (Treated Water Exchange with Agricultural Water Users):** The Southland WWTF provides secondary treatment for a mixture of domestic and industrial wastewater from part of the Nipomo community. This alternative would include a groundwater exchange program involving delivery of recycled water from Southland WWTF to potential agricultural users within the vicinity of the groundwater pumping depression previously identified in the Nipomo Mesa. As directed by NCSD staff, the boundary limits of this alternative include the depressed groundwater basin bounded by the Oceano and Santa Maria River Faults and within the NMMA.

The proposed groundwater exchange of recycled water for agricultural production will not introduce a new supplemental water source from outside the NMMA; however, it will be intended to provide a means to manage and redistribute the water balance within the subject area of the NMMA. As proposed, this scenario will provide for the transfer of a non-potable water source (reclaimed water from Southland WWTF) to potential agricultural users for either direct reuse in irrigation of crops or for percolation and subsequent recovery. In exchange, the groundwater previously pumped by the same agricultural users would either be: (1) directly pumped (at the subject wells) and transmitted for use by NCSD; or (2) indirectly extracted by NCSD at existing or new well locations.

## 2.0 PERMITTING REQUIREMENTS

This section lists and discusses the regulatory agencies that have jurisdiction and their permitting requirements within the area of the water supply alternatives under consideration. Proposed alternatives would require various federal, state, and local approvals, depending on the alternative. Refer to Table 1 for a general list of anticipated permitting agencies that would be involved with permitting one or more alternatives. Presented below is a description of each regulatory agency's anticipated role in review and permitting of the proposed alternatives.

### 2.1 FEDERAL AGENCIES

**United States Army Corps of Engineers (USACE).** The USACE would likely be the lead federal agency for the proposed project for placement of fill (including temporary trench spoils) within navigable waters of the U.S. under Section 404 of the Clean Water Act. The USACE also issues permits for construction of facilities within navigable waters in accordance with Section 10 of the Rivers and Harbors Act of 1899. During review of a permit application, the USACE will consult with the U.S. Fish and Wildlife Service (USFWS) and National Oceanic and Atmospheric Administration, National Marine Fisheries Service (NOAA Fisheries) to identify potential effects to federally-listed endangered and threatened species as required under Section 7 of the Endangered Species Act (ESA). A Biological Assessment would be required as part of this consultation to provide sufficient information for the USACE, USFWS, and NOAA Fisheries to fully determine the project's potential to affect federally-listed threatened or endangered species. A review of potential impacts to cultural or historical resources is coordinated through consultation with the State Historic Preservation Office.

A Jurisdictional Waters of the U.S. survey (wetlands delineation) may also be required to identify wetlands that may be impacted by the project. The USACE's jurisdiction under Section 404 of the Clean Water Act extends to the ordinary high water mark of a river or stream.

USACE permitting would likely affect Alternatives 1, 2, 3, and 4, wherever new construction of conveyance pipelines or other facilities would impact federal waters. Without more detailed engineering specifications, it is unclear to what extent federal waters may be affected. Depending on the alternative selected for implementation, the proposed project may potentially fall within one or more Nationwide Permits (NWP) developed by the USACE for major routine types of construction projects within federal waters.

**National Oceanic and Atmospheric Administration, National Marine Fisheries Service (NOAA Fisheries).** NOAA Fisheries is responsible for the protection of marine fish and mammal species by administering the regulations listed in the ESA, Marine Mammal Protection Act, and the Magnuson-Stevens Fishery Management and Conservation Act. Based on the preliminary information available, NOAA Fisheries may not be involved for onshore portion of the alternatives unless the selected project would result in disturbance within the Santa Maria River or Nipomo Creek. The USACE would consult with NOAA Fisheries for potential impacts to marine fisheries and marine mammals for an ocean outfall pipeline proposed under alternative Nos. 1 or 2.

**United States Fish and Wildlife Service (USFWS).** The USFWS will be requested to review the project by the USACE with respect to potential impacts to federally-listed threatened

or endangered species. Such consultation will be initiated during the 404 or 10 permit process. Impact of critical habitat may also result in seasonal restrictions and recommendations for habitat restoration. Potential endangered species impacts under alternatives 1 through 4 may include potential takes of listed species known to occur in creeks and wetlands along pipeline routes. Under the Alternative 2 scenario, impacts to water quality or quantity within Oso Flaco Lake or creek could affect habitat. The USFWS would be a key stakeholder in mitigation of potential affects of water withdrawals from the Oso Flaco lake watershed. Additionally, impacts from desalination proposals would be required to avoid takes of habitat or individual Western snowy plover or least tern from proposed seawater intake structures or brine outfall lines.

## 2.2 STATE AGENCIES

**Central Coast Regional Water Quality Control Board (RWQCB).** The RWQCB's primary responsibility is to protect the quality of the surface and groundwater within the Central Coast region for beneficial uses. The duty is carried out by formulating and adopting water quality plans for specific ground or surface water bodies, by prescribing and enforcing requirements on domestic and industrial waste discharges, and by requiring cleanup of water contamination and pollution.

Pursuant to Section 401 of the Clean Water Act, the USACE permit under Section 404 is not active until the State of California first issues a water quality certification to ensure that a project will comply with state water quality standards. The authority to issue water quality certifications in the project area is vested with the RWQCB. All of the considered alternatives would involve construction activities which would expose greater than one acre of disturbed construction area to stormwater runoff, and would require enrolling for coverage under the General Construction Stormwater Permit issued by the State Water Resources Control Board and enforced by the RWQCB.

Alternative No. 1 (Seawater/Cooling Water) would likely include requirement of a National Pollutant Discharge Elimination System/Waste Discharge Requirements (NPDES/WDR) permit from the RWQCB for brine discharge to the ocean associated with any of the three scenarios. Also, Alternative No. 2 (Oso Flaco Agricultural Return Water) may also involve the discharge of treated brine to the ocean, requiring a NPDES/WDR permit from the RWQCB. Brine discharges would be required to meet state and federal water quality standards for ocean disposal in accordance with the California Ocean Plan. Impacts to marine organisms from brine discharge would also be considered a potential significant impact under the CEQA.

**California Coastal Commission.** The California Coastal Commission regulates development activities along California's coastline and within the designated coastal zone under the authority of the California Coastal Act. Within the Nipomo area, the coastal zone boundary extends inland from the coastline to Highway 1. Projects approved by the County within the coastal zone can be appealed to the Coastal Commission for independent review for consistency with the Coastal Act. Additionally, projects with construction activities seaward of mean high tide line or affecting coastal streams or environmental sensitive habitat areas (ESHAs) fall within the Coastal Commission's original jurisdiction and would require a Coastal



Development Permit issued by the Coastal Commission. Alternatives 1 and 2 would be located within the coastal zone and would be subject to Coastal Commission review and approval.

**California State Lands Commission (CSLC).** The CSLC manages the state's submerged tidelands along the California coast from the mean high tide line and seaward for three nautical miles. Construction of facilities within CSLC jurisdiction would require a state lands lease. Approval of the state lands lease is made by the commission, composed of the lieutenant governor, the state controller, and the state finance director. Alternatives 1 and 2 would include ocean outfall structures placed in CSLC jurisdiction and would require a state lands lease.

**California Department of Fish and Game (CDFG).** CDFG administers Section 1600 of the California Fish and Game Code. The regulation requires a Lake or Streambed Alteration Agreement (SAA) between CDFG and the applicant before the initiation of any construction project that will: 1) divert, obstruct, or change the natural flow or the bed, channel, or bank of any river, stream, or lake; 2) use materials from a streambed; or 3) result in the disposal or deposition of debris, waste, or other loose material where it can pass into any river, stream, or lake.

The CDFG also administers a number of laws and programs designed to protect fish and wildlife resources. Principle of these is the California Endangered Species Act of 1984 (CESA - Fish and Game Code Section 2050), which regulates the listing and take of state endangered (SE) and threatened species (ST). Under Section 2081 of CESA, CDFG may authorize the take of an Endangered and/or Threatened species, or candidate species through an Incidental Take Permit. However, plant or animal species that are "Fully Protected" under state law cannot be taken and no Incidental Take Permits may be issued. In the project area, the California least tern, the Southern sea otter, and the white-tailed kite are all fully-protected species.

Alternatives 1, 2, 3, and 4 would likely require SAA permits from the CDFG for pipeline creek crossings. The CDFG is a trustee agency under CEQA, and would likely provide comment on the CEQA document regarding potential project impacts to animal and plant species designated rare, threatened/endangered, or fully-protected status.

**California Department of Health Services (DHS).** DHS is responsible for overseeing the quality of water once it is in storage and distribution systems. DHS oversees the self-monitoring and reporting program implemented by all water purveyors, performs inspections, and assists with financing water system improvements for the purpose of providing safer and more reliable service. A Water Supply Permit Amendment would be required from DHS for any of the alternatives under consideration.

**California Department of Transportation (Caltrans).** Caltrans is responsible for managing California's highway and freeway systems and works collaboratively with local agencies to ensure proper management of local roadway systems. Caltrans reviews all requests from utility companies, developers, volunteers, nonprofit organizations, etc., desiring to conduct various activities within their right-of-way (ROW). Construction activity being proposed along a Caltrans ROW would require a Standard Encroachment Permit from Caltrans prior to project implementation. This could potentially occur with all alternatives except Alternatives 5 and 6.



## 2.3 LOCAL AGENCIES

**County of San Luis Obispo.** All of the alternatives would be within the jurisdiction of San Luis Obispo County land use regulations (SLO County). SLO County will require that a conditional (or minor) use permit, grading permit, and building permit be issued for the construction and operation of the project facilities (i.e. pipelines, wells, and storage) and will analyze the project to determine consistency with any applicable standards or policies. SLO County may impose specific requirements/conditions be incorporated into the permit governing the design or operation of the project and may not approve the permit unless it is found to be consistent with the County's General Plan and Land Use Ordinance. The County would be a permitting agency under CEQA and would rely on the NCSD's CEQA determination in issuance of permits. Encroachment along county roadways would require a standard encroachment permit issued by the County Public Works Department.

**San Luis Obispo County Air Pollution Control District (APCD).** The APCD would review proposed project for compliance with applicable Federal, State and local air quality control criteria. For any of the alternatives, NCSD likely would be required to submit a Construction Activity Management Plan to the APCD which will address construction-related dust control and equipment emissions. The CAMP will be required to address construction-related air impacts through various mitigation techniques. Detailed documentation of proposed project emissions (such as from organics removal during treatment) will be required to obtain Authority to Construct/Permit to Operate permits, if needed.

**San Luis Obispo County Division of Environmental Health.** The County Division of Environmental Health (SLODEH) is the local approval agency for issuance of water supply well permits or injection wells within a drinking water aquifer. Wellhead protection regulations require a minimum separation of water supply wells from wastewater disposal facilities. Under Title 22 regulations, the SLODEH may require any injected water to meet drinking water standards prior to injection.

## 2.4 CALIFORNIA ENVIRONMENTAL QUALITY ACT

The NCSD would act as the lead agency for compliance with the California Environmental Quality Act (CEQA) for implementation of any of the water supply alternatives under consideration. The NCSD would prepare an Initial Study/ Mitigated Negative Declaration (IS/MND) or Environmental Impact Report (EIR) for the selected project, depending on the level of impacts anticipated. During the CEQA process, NCSD would consult with other state and local agencies regarding concerns and suggested mitigation for environmental impacts. Environmental issues that arise during CEQA processes will be addressed through project design modifications or mitigation measures included in the CEQA document. Following completion of the CEQA process, the NCSD would submit permit applications to regulatory agencies as appropriate and negotiate permit conditions as needed.



**Table 1. Permit Requirements Summary**

Agency	Permit/Approval	Regulated Activity	Authority
<b>Federal Agencies</b>			
U.S. Army Corps of Engineers (USACE)	Section 404 permit Section 10 permit	Discharge of dredged or fill material into water of the U.S. during construction. Jurisdictional water include territorial seas, tidelands, rivers, streams, and wetlands	Section 404 Clean Water Act (33 USC 1344). Rivers and Harbors Act
U.S. Fish and Wildlife Service (USFWS)	Endangered Species Act, Section 7 consultation	Impacts to federally-listed species and species proposed for listing.	16 USCA 1513 50 CFR Section 17
NOAA Fisheries	ESA, Section 7 consultation	Impacts to federally-listed species and species proposed for listing.	16 USCA 1513 50 CFR Section 17
<b>State of California Agencies</b>			
Regional Water Quality Control Board	Section 401 Water Quality Certification SWPPP Permit NPDES/WDRs	Discharges that may affect surface and ground water quality.	Clean Water Act Porter-Cologne State Water Quality Act (1969)
California Coastal Commission	Appeal Jurisdiction within Coastal Zone	Projects within Coastal Zone approved by County can be appealed to Coastal Commission for review and approval.	California Coastal Act
California Department of Fish and Game (CDFG)	1602 Permit Section 2081 Management Agreement	Crossing of streams and rivers that will result in disturbance to the streambed. Potential adverse effects to State-listed species	Sections 1601-1607 of California Fish and Game Code. Section 2081 of the Fish and Game Code
California State Lands Commission	State Lands Lease	Project activities offshore of mean high tide line.	California Public Resources Code, Division 6.
California Department of Health Services	Water Supply Permit Amendment	New water source	Ca Health and Safety Code, Div. 104, Part 12, Chapter 4 Article 7, Section 116525
California Department of Transportation	Standard Encroachment Permit	Construction activity within Caltrans right-of-way.	California Streets and Highway Code
<b>Local Agencies</b>			
County of San Luis Obispo Planning and Building Department	Development, Grading, Building Permit	Land use, grading, drainage, encroachment permit	San Luis Obispo County Code
San Luis Obispo APCD	Authority to Construct	Emissions associated with construction may require permits.	Clean Air Act
County of San Luis Obispo Division of Environmental Health	Well Construction Permit	Construction new water supply wells	California Water Code

## 3.0 ENVIRONMENTAL CONSTRAINTS

The following section describes the potential environmental constraints associated with the six water supply alternatives under consideration by the NCSD. Based on Padre's initial review of the project alternatives and review of permitting requirements, the probable issues that will need to be addressed during the permitting process for this project are biological resources including wetlands, cultural resources, geology and soils, and hydrology/ water quality. The following provides an overview of the environmental issue areas with emphasis on the sensitive biological resources that are expected to occur within the project area due to the presence of suitable habitat. The resources and required mitigation, if any, will be the focus of the respective regulatory agency review during the permit acquisition phase of the project.

### 3.1 BIOLOGICAL RESOURCES

Padre conducted a desk-top review to determine potential biological resource constraints within the vicinity of the identified water supply alternative location. This review included a query of the California Natural Diversity Database (CNDDDB [CNDDDB, 2006]) for the purposes of identifying documented occurrences of special-status plant and animal species within the vicinity of the alternative projects. Figures 2 through 5 illustrate the known occurrences of special-status species in relationship to the water supply alternatives under consideration. The figures illustrate a representative sample or ranges for known species occurrences.

#### 3.1.1 Federally-Listed Animal Species

**California red-legged frog (*Rana aurora draytonii*).** The California red-legged frog (CRLF) is a federally-listed threatened species and a California species of special concern. The CRLF occurs in different habitats depending on their life stage and season. CRLF breed from November through March. All stages are most likely to be encountered in and around breeding sites, which include marshes, springs, permanent and semi-permanent natural ponds, ponded and backwater portions of streams, as well as artificial impoundments such as stock ponds, irrigation ponds, and siltation ponds. This species prefers dense emergent and bank vegetation including willow (*Salix* sp.), cattail (*Typha* sp.), and bulrush (*Scirpus* sp.). The absence of these plant species within the site does not exclude the possibility that the site provides CRLF habitat, but the presence of one or all of these plants is an important indicator that the site may provide foraging or breeding habitat (USFWS, 2005).

CRLF is a concern for alternatives 1, 2, and 4 due to the known presence or suitable habitat in creeks and wetlands within the project Nipomo area, especially around Oso Flaco Lake and Oso Flaco Creek. As such, formal Section 7 consultation pursuant to Section 404 of the Clean Water Act would be useful between the USACE and the USFWS to further assess potential CRLF impacts due to project implementation and the need for project-specific avoidance and minimization measures. This would include preparation of a Biological Opinion (BO) by the USFWS which will ultimately result in approval for authorized individuals to survey for and, as necessary, relocate CRLF from the project area during project implementation (i.e., "Take Statement").

**Steelhead – Southern California ESU (*Oncorhynchus mykiss irideus*).** Steelhead have been divided into 15 evolutionary significant units (ESU) based on similarity in life history, location, and genetic markers. The Southern California ESU was listed as federally endangered by the NOAA Fisheries in 1997. Southern California steelhead is also a California species of special concern. Steelhead are an anadromous form of rainbow trout that reproduce in freshwater, but spend much of their life cycle in the ocean, where increased prey density provides a greater growth rate and size. The Southern California ESU includes all naturally spawned populations of steelhead (and their progeny) in streams from the Santa Maria River (inclusive) to the southern extent of the species' range (U.S. – Mexico border). Historical information suggests that the Santa Maria River supported a steelhead run in the early 1900s. Currently, there is no evidence suggesting presence of this species in the Santa Maria River for several decades. However, it is assumed this species has the potential to occur within the Santa Maria River during periods of adequate flow (i.e., January through April).

Steelhead may not be a significant species of concern for the alternatives under consideration unless there would be an affect to the Santa Maria River. Existing fish migration barriers that exist at Nipomo Creek currently impede migration of steelhead upstream of the Hutton Road area. As part of the USACE permit process, Section 7 consultation per the ESA will be conducted with NOAA Fisheries to further assess potential steelhead impacts due to project implementation and the need for project-specific avoidance and minimization measures.

**Western Snowy Plover (*Charadrius alexandrinus*).** The coastal population of nesting western snowy plover is federally-listed threatened species and a California species of special concern. The western snowy plover frequents sandy beaches and estuarine shores within the project site; requiring sandy, gravelly or friable soil substrates for nesting. Western snowy plover breeding and nesting is currently being monitored by State Parks as part of their ongoing efforts to document snowy plover activity within the area. Plovers are known to occur in suitable habitat areas from Guadalupe Dunes to Pismo Beach. This species would be of concern for alternative Nos. 1 and 2 associated with any construction activities within Nipomo-Guadalupe dune complex.

**California Least Tern (*Sterna antillarum brownii*).** The California least tern is a migratory bird that is protected under both the provisions of the federal and California endangered species acts as endangered. Many areas of coastal habitat for the California Least Tern have been significantly modified by human activities, such as marinas and industrial development, and housing. Other threats to tern populations include increased predation (a result of anthropogenic factors and habitat modification), potential for washouts by significantly high tides, and recreation. Least tern spring migrants arrive and move through the area around the latter part of April. Egg-laying usually occurs at most of the sites by late May, with hatching chicks present in mid June. Least tern are known to occur in suitable habitat areas from Guadalupe Dunes to Pismo Beach.

### 3.1.2 Special-Status Plants

**Gambel's water cress (*Rorippa gambellii*).** Gambel's watercress is a federally and state-listed endangered species in the mustard family (Brassicaceae). Gambel's water cress occurs in freshwater or brackish marshes and swamps between 5 and 330 meters. This

species typically blooms from April to September. Gambel's water cress is known to occur in only four remaining locations in California.

**La Graciosa thistle (*Cirsium loncholepis*).** La Graciosa thistle is a federally endangered, state threatened species, and a CNPS List 1B species. This species is a perennial herb in the sunflower family (Asteraceae) that typically blooms May through August. La Graciosa thistle occurs in coastal dunes, brackish marshes, or riparian scrub often in association with lake edges, riverbanks, and other wetlands.

**Nipomo Mesa lupine (*Lupinus nipomensis*).** Nipomo Mesa lupine is an annual herb in the pea family (Fabaceae) that occurs in coastal dune habitat between 10 and 50 meters. This species typically blooms from December through May. Nipomo Mesa lupine is a federally endangered, state threatened species, and a CNPS List 1B species. This species is known from only one extended occurrence of five populations on Nipomo Mesa in San Luis Obispo County.

**San Luis monardella (*Monardella frutescens*).** San Luis monardella is a rhizomatous herb in the mint family (Lamiaceae). San Luis monardella is a CNPS List 1B species that is known to occur in San Luis Obispo and Santa Barbara Counties. This species inhabits coastal dunes and coastal scrub habitat associated with sandy soils between 10 and 200 meters. San Luis monardella generally blooms from May to September.

**Blochman's leafy daisy (*Erigeron blochmaniae*).** Blochman's leafy daisy is a rhizomatous herb in the sunflower family (Asteraceae) known to occur in San Luis Obispo and Santa Barbara Counties. Blochman's leafy daisy is a CNPS List 1B species. This species typically blooms from June through August and occurs in coastal dune and coastal scrub habitat between 3 and 45 meters.

**Dune larkspur (*Delphinium parryi* ssp. *blochmaniae*).** Dune larkspur is a CNPS List 1B species known to occur in San Luis Obispo, Santa Barbara, and Ventura Counties. This species is a perennial herb in the buttercup family (Ranunculaceae) that inhabits coastal dune and chaparral habitat between 0 to 200 meters. Dune larkspur generally blooms from April through May.

### 3.1.3 Other Potentially Occurring Special-Status Species

Although species described in this section are not indicated on the occurrences maps included (Figures 2 – 5), they have been included based on their occurrences within the Nipomo area.

**Coast horned lizard (*Phrynosoma coronatum frontale*).** The coast horned lizard is a federal species of concern and a California species of special concern that occurs in a variety of open habitats that provide sites for basking, sandy or sandy-loam substrates for night-time burial, and a suitable prey base (the species feeds almost exclusively on native ants). It was historically distributed throughout the Central and Coast Range of California, but now occurs at scattered, disjunct locations within this former range. The coast horned lizard produces clutches of 6 to 21 eggs from May to June and hatching typically occurs in August through September. A single coast horned lizard was observed within the non-native grassland/coastal sage scrub habitat area along the south side of the Santa Maria River in 2005 (Douglas Wood &

Associates, Inc., 2006). The coast horned lizard has the potential to occur throughout the Nipomo area. As such, mitigation to avoid and/or minimize impacts to coast horned lizard during project implementation would be determined during consultation with CDFG.

**Southwestern pond turtle (*Clemmys marmorata pallida*).** The southwestern pond turtle is a federal species of special concern and a California species of special concern. It is an aquatic turtle inhabiting streams, marshes, ponds, and irrigation ditches within woodland, grassland, and open forest communities. However, it requires upland sites for nesting and over-wintering. Stream habitat must contain large, deep pool areas (six feet) with moderate-to-good plant and debris cover, and rock and cobble substrates for escape retreats. Southwestern pond turtle was observed in Nipomo Creek during a reconnaissance-level survey conducted by Padre in July 2004. Therefore, it has been determined that this species has the potential to occur within Nipomo Creek area during implementation, including portions of the Santa Maria River. As such, mitigation to avoid and/or minimize impacts to southwestern pond turtle during project implementation would be determined during consultation with USFWS and CDFG.

**Two-striped garter snake (*Thamnophis hammondi*).** The two-striped garter snake is a California species of special concern which is highly aquatic and is typically found near permanent fresh water streams associated with willow habitat. This species occurs historically and currently throughout southern California streams, including the central coast. Small mammal burrows are used as over-wintering sites for the snake (Jennings, 1994). This species has the potential to occur within Nipomo Creek. Mitigation to avoid and/or minimize impacts to two-striped garter snake during project implementation would be determined during consultation with CDFG.

**Blochman's ragwort (*Senecio blochmaniae*).** Blochman's ragwort is a CNPS list 4 species. This species typically occurs in coastal dunes and coastal floodplains. Blochman's ragwort is a subshrub, perennial herb that blooms from May to October. A sparsely scattered population of this species (<50) was identified by Padre in 2004 within the northern sand banks of the Santa Maria River channel, directly adjacent to the existing concrete processing facility located directly west of Highway 101. Suitable habitat for this species exists along the Santa Maria River corridor. Measures to avoid and/or mitigate impacts to Blochman's ragwort would be determined during consultation with CDFG.

**Nuttall's milk-vetch (*Astragalus nuttallii* var. *nuttallii*).** Nuttall's milk vetch is a CNPS list 4 species, which was identified in the project area during the 2005 biological survey of the project area (Douglas Wood & Associates, Inc., 2006). Both locations were along the southern levee of the Santa Maria River within the disturbed grassland and coastal sage scrub habitat areas. Suitable habitat for this species exists along the Santa Maria River corridor. Measures to avoid and/or mitigate impacts to Nuttall's milk-vetch would be determined during consultation with CDFG.

**Monarch Butterfly (*Danaus plexippus*).** The Monarch butterfly does not have federal or state listing status, but is included as a sensitive species by the CNDDDB and is a species of local concern in San Luis Obispo County. Winter roost sites extend from Northern Mendocino to Baja California, Mexico. The listing by CDFG is based on limited wintering roost sites within the Central California coast portion of the butterfly's West Coast wintering range. The Monarch butterfly can be found in a variety of habitats, especially those supporting milkweed plants

(*Asclepias* sp.), the primary food source of the caterpillars. These butterflies frequent grasslands, prairies, meadows, and wetlands, but avoid dense forests. In the winter, Monarchs cluster together in large numbers in eucalyptus, cypress, and Monterey pine trees, often on the edge of open areas. Measures to avoid and/or minimize impacts to Monarch butterflies and/or pre-activity surveys would be determined during the CEQA process and consultation with CDFG.

**Raptor and Migratory Bird Species.** Raptor and migratory bird species protected under the Migratory Bird Treaty Act (16 USC 703-712); CDFG Code Section 3503, and CDFG Code Section 3503.5 may nest within the area during project implementation. These include ground nesters (western meadowlark and lark sparrow), small tree/shrub nesters (bushtit, American robin, northern mockingbird, loggerhead shrike, house finch, and lesser goldfinch) and several raptors which require large trees, such as eucalyptus for nesting purposes (turkey vulture, red-tailed hawk, red-shouldered hawk, great-horned owl, barn owl, white-tailed kite and Cooper's hawk). Short-term impacts to these species may occur from vegetation clearing, debris removal, trenching and HDD operations, dust deposition and noise disturbance associated with the construction activities. Vegetation removal and subsequent grading activities may destroy nests, nestlings, or hatchlings of these protected bird species, and would be considered a significant impact. As such, measures, such as seasonal constraints and/or pre-activity nesting bird surveys to avoid and/or minimize impacts to raptors and migratory birds, would be determined during the CEQA process and consultation with CDFG.

### 3.2 WETLANDS/WATERS OF THE U.S.

The USACE is responsible for the issuance of permits for the placement of dredged or fill material into waters of the United States (waters) pursuant to Section 404 of the Clean Water Act (33 USC 1344). As defined by the USACE at 33 CFR 328.3(a)(3), waters are those that are currently used, or were used in the past, or may be susceptible to use in interstate or foreign commerce, including all waters that are subject to the ebb and flow of the tide; tributaries and impoundments to such waters; all interstate waters including interstate wetlands; and territorial seas. (Note: Based on the recent U.S. Supreme Court decision in *Solid Waste Agency of Northern Cook County v. U.S. Army Corps of Engineers* [2001], and guidance from the U.S. Army Corps of Engineers and U.S. Environmental Protection Agency [2001], the Federal government no longer asserts jurisdiction over isolated waters and wetlands under Section 404 of the Clean Water Act based on the "migratory bird rule." Further guidance on the issue of isolated wetlands and waters is expected (U.S. Army Corps of Engineers, 2001).

Wetlands are a special category of waters, and are defined at 33 CFR 328.3(b) as: "...those areas that are inundated or saturated by surface or groundwater at a frequency and duration sufficient to support, and that under normal circumstances do support, a prevalence of vegetation typically adapted for life in saturated soil conditions. Wetlands generally include swamps, marshes, bogs, and similar areas."

In non-tidal waters, the lateral extent of USACE jurisdiction is determined by the ordinary high water mark (OHWM), which is defined as the: "...line on the shore established by the fluctuations of water and indicated by physical characteristics such as clear, natural line impressed on the bank, shelving, changes in the character of soil, destruction of terrestrial



*vegetation, the presence of litter and debris, or other appropriate means that consider the characteristics of the surrounding areas.” (33 CFR 328[e]).*

In addition, a wetland definition has been adopted by the USFWS to include both vegetated and non-vegetated wetlands, recognizing that some types of wetlands may lack vegetation (e.g., mudflats, sandbar, rocky shores, and sand flats), but still provide functional habitat for fish and wildlife species (Cowardin, et al., 1979). These wetlands are defined as “...lands transitional between terrestrial and aquatic systems where the water table is usually at or near the surface or the land is covered by shallow water. For purposes of this classification, wetlands must have one or more of the following three attributes: (1) at least periodically, the land supports predominantly hydrophytes; (2) the substrate is predominantly undrained hydric soil; and (3) the substrate is non-soil and is saturated with water or covered by shallow water at some time during the growing season of each year.” Some of the USFWS-defined wetlands are not regulated by the Federal government.

The upper (landward) limit of USFWS-defined wetlands are the boundary between land with predominantly hydrophytic cover and land with predominantly mesophytic or xerophytic cover; the boundary between soil that is predominantly hydric and soil that is predominantly non-hydric; or in the case of wetlands without vegetation or soil, the boundary between land that is flooded or saturated at some time each year and land that is not (Cowardin et al., 1979). The lower limit in inland areas is established at a depth of 6.6 feet below the water surface; unless emergent plants, shrubs, or trees grow beyond this depth, at which the deepwater edge of such vegetation is the boundary (Cowardin et al., 1979).

Based on the definitions above, both waters of the U.S. and USACE-defined wetlands are present within the Santa Maria River floodplain, Nipomo Creek, and the Oso Flaco Lake and Oso Flaco Creek areas. Oso Flaco Lake occupies a surface area of 82 acres is classified by the USFWS as a palustrine emergent wetland. Additionally, several of the nearby drainages and associated storage ponds that act as tributaries to Nipomo Creek and the Santa Maria River, such as those occurring along the Nipomo Mesa have the potential to fall under the USACE jurisdiction. Wetlands and creeks impacted by pipeline installation activities would need to be restored or replaced. In the event a selected alternative would affect designated wetlands, an agency-approved Wetlands Mitigation and Monitoring Plan would need to be implemented as part of the project.

### **3.3 CULTURAL RESOURCES**

Alternatives involving construction activities and placement of project-related infrastructure (i.e. pipelines, tanks, treatment plants) would require evaluation and analysis of the potential for effect on culturally-sensitive resources. Alternatives would require delineation of pipeline routes and placement of project facilities prior to implementing cultural records searches and/or surveys. The Dana Adobe, located on South Oakglen Avenue, is a designated California Historical Landmark. Sensitive cultural sites are known to exist near the Dana Adobe in eastern Nipomo.

### 3.4 GEOLOGY AND SOILS

The information discussed in this section was determined through a review of the San Luis Obispo County Safety Element (1998). Depending on jurisdiction, project alternatives would be reviewed for geologic (e.g. active faults, liquefaction) and other safety issues. Within the general project area (i.e. south-western San Luis Obispo County and the Santa Maria area), there is a potentially active fault (Santa Maria River Fault) and areas of moderate to high liquefaction, particularly in the coastal dune areas around Oso Flaco Lake. Areas located within 100-year flood plain zones include the Santa Maria River and the Oso Flaco Lake area. This area is also considered a “dam inundation zone”. Additionally, areas east of the Guadalupe-Nipomo Dunes Complex (e.g. Conoco-Phillips Refinery, Nipomo) are subject to substantial wildland fire risk. Although no specific permits may be required in relation to these hazards, the projects will be reviewed for land-use policy consistency during the CEQA and County permitting process.

### 3.5 HYDROLOGY AND WATER QUALITY

**Water Quality.** It is Padre’s understanding that Boyle will provide the NCSO with an assessment of water quality issues associated with the development of the water supply alternatives and provision of potable water in accordance with state and federal water quality standards within a separate document. The following discussion focuses on water quality and hydrologic impacts that may arise from the construction of each of the water supply alternatives. Water quality impacts would be connected to construction site erosion/spills/etc, frac-outs (as discussed), and discharges from each alternative. Hydrologic impacts would be due to extractions from certain sources and discharges to certain locations.

With increased development and storm water runoff, a wide variety of nutrients and constituents of concern have been introduced into state waters. Nutrient wastes in the form of sewage, agricultural fertilizers, and manure lead to reduced dissolved oxygen in surface waters and limit the capacity of water to support aquatic organisms. Constituents of concern, such as industrial wastes, insecticides, and herbicides, can poison wildlife and become concentrated in the food chain.

Oso Flaco Lake and Oso Flaco Creek has been identified by the RWQCB as an “impaired water body” under Section 303d of the Clean Water Act because of elevated levels of nitrates associated with irrigated agriculture within the watershed. Oso Flaco Creek is also listed as an impaired water body for elevated fecal coliform bacteria concentrations. Restoration of water quality at Oso Flaco Lake by the RWQCB has focused primarily on agricultural return water quality and quantity (RWQCB, 2006). Additionally, Nipomo Creek has been designated an “impaired water body” under Section 303d because of elevated fecal coliform bacteria concentrations.

**HDD Drilling Techniques.** Horizontal directional drilling (HDD) techniques involve the installation of pipelines without open-trenching. HDD installation methods are environmentally-preferable to open-trenching in most cases because it can be utilized to avoid impacts to sensitive resources such as creeks and wetlands. “Frac-outs”, or the loss of drilling fluids to the surrounding environment, are a risk in utilizing HDD drilling techniques. The potential for “frac outs” should be minimized by incorporating engineering and geologic information and

developing a drilling and drilling fluid monitoring program that is appropriate for the existing subsurface geological conditions. The HDD drilling plans should specify drilling parameters such as drilling equipment capacity, directional bore depths, entry, and exit angles. Drilling fluid properties including fluid weight, viscosity, water loss, and gel strength should be designed and monitored by a qualified engineer. Only bentonite-based drilling mud is allowed for use within state waters in California. Compounds that may be toxic to fish are prohibited from use as additives to drilling mud mixtures.

## 4.0 SUMMARY AND RECOMMENDATIONS

The following section provides a summary of the permitting issues and requirements for the water supply alternatives under consideration by the NCSD. A summary of the permitting requirements is presented in Table 2, followed by general recommendations on a permitting strategy.

### 4.1 SUMMARY OF ENVIRONMENTAL/PERMITTING ISSUES BY ALTERNATIVE

The following provides an overview of the expected agency jurisdictional issues and associated permits that may be required for the various water supply alternatives:

**Alternative No. 1 (Seawater/Cooling Water):** Although specific locations are not identified under this alternative, proposals for desalination facilities along California's coast have raised unique issues that would need to be addressed through project design and agency negotiations. The California Coastal Commission has raised concerns about brine disposal impacts to marine resources. Open seawater intakes structures have been effectively prohibited by the Coastal Commission due to entrainment and take of marine organisms. One method of mitigating concerns associated with desal intake system construction within the beach areas would be to utilize existing intake structures or outfall pipelines. As a result of concerns about open ocean intake pipelines, most desalination facilities currently under consideration along the Central and South Coasts of California include beach water intake systems that utilize wells or intake galleries that would draw brackish water from permeable zones within the coastline and beach areas.

The design of a beach well intake system can result in a separate set of environmental impacts. The Nipomo-Guadalupe Dune complex is a unique and sensitive area that has been heavily protected by land acquisition, land use planning, and regulatory activities. Numerous threatened or endangered species, such as the Western snowy plover and the California least tern, are present within the dune complex and along the beach areas of the Nipomo-Guadalupe dunes.

The area around the Conoco-Phillips refinery is known to contain special-status plant species (e.g. Nipomo Mesa Lupine, La Graciosa Thistle, Dune Larkspur), as well as sensitive habitat (Central Coast Dune Scrub).

Selection of one of the seawater or cooling water alternatives will require review and approval of a Coastal Development Permit by the County of San Luis Obispo which would be appealable to the Coastal Commission. The State Lands Commission would require a state lands lease for placement of an ocean outfall line in state waters. The ocean outfall line would also require a Section 404/10 permit from USACE for construction in navigable waters. Pipeline

facilities associated with any of the options would likely require permits from the USACE, RWQCB, and CDFG for pipeline creek crossings. A Caltrans encroachment permit would be required for pipeline crossings at Highway One. A RWQCB NPDES/WDR permit would be required for the disposal of brine into the Pacific Ocean or other form of injection or disposal options that may affect surface or ground water quality.

**Alternative No. 2 (Oso Flaco Lake Watershed):** This alternative would involve treating shallow groundwater or agricultural runoff within the Oso Flaco Lake watershed and delivering the treated water to the NCS D distribution system. This alternative may include returning a portion of the treated flow to the watershed for environmental uses.

The Oso Flaco Creek Watershed covers approximately 10,370 acres. The western terminus for the watershed is Oso Flaco Lake, owned by California State Parks. Oso Flaco Creek flows out of the lake and meanders ¼-mile to the Pacific Ocean through active sand dunes. Oso Flaco Lake is the largest of four small freshwater lakes located in the Guadalupe Nipomo Dunes Complex. The freshwater lake occupies a surface area of 82 acres and is classified by the U.S. Fish and Wildlife Service as palustrine emergent wetlands, a valuable habitat for wildlife, and subsequently a resource for many recreational and educational activities.

Oso Flaco Lake and Little Oso Flaco Lake are usually at maximum pool due to the steady flow of agricultural runoff. It has been estimated that 6,371 acres in the watershed are irrigated, primarily with pumped groundwater, and that 17,564 acre-feet per year (AFY) of water are applied, resulting in 968 AFY of agricultural runoff. Efforts are currently underway to improve irrigation efficiency to both reduce the quantity of water applied and the volume of agricultural runoff. It has been estimated that if 100% of the irrigated area were to adopt sprinkler/drip systems, the annual runoff volume would decrease to 440 AFY (CRCD, 2004).

The critical environmental issue associated with this alternative is ensuring that significant negative impacts would not occur to Oso Flaco Lake, Little Oso Flaco Lake or associated creeks. Impacts would be considered significant if less environmental flows to the creeks and lakes would result in reduced habitat for endangered species. The County of San Luis Obispo has designated Oso Flaco Lake as a Sensitive Resource Area in its South County Coastal Area Plan (1988). Activities within Sensitive Resource Areas are required to undergo extra scrutiny to ensure that damage to the resource will not result from proposed projects. Hydrologic modeling of the watershed would be required to show that water levels within the lakes would not be significantly affected through water withdrawal upstream. A project that improves water quality in Oso Flaco Lake could be leveraged as a desirable outcome for stakeholders in the area, including State Parks, RWQCB, USFWS, CDFG, the Dunes Center, and agricultural water users.

This alternative project would require review and approval of Coastal Development Permits by the County of San Luis Obispo and the Coastal Commission for the outfall line extending into the ocean. The State Lands Commission would require a state lands lease for placement of an ocean outfall line. The ocean outfall line would also require a Section 404/10 permit from USACE for construction in navigable waters. Pipeline facilities associated with any of the options would likely require permits from the USACE, RWQCB, and CDFG for pipeline creek crossings. A Caltrans encroachment permit would be required for pipeline crossings at Highway One. A RWQCB NPDES/WDR permit would be required for the disposal of brine into

the Pacific Ocean or other form of injection or disposal options that may affect surface or ground water quality.

Formal Section 7 consultation would be required with the USFWS due to the presence of CRLF within the Oso Flaco Creek area. NOAA Fisheries would be consulted by the USACE for potential impacts associated with an ocean outfall to marine fisheries and marine mammals. The level of disturbance during construction of pipelines to environmentally sensitive areas could be minimized through the use of HDD construction techniques.

**Alternative No. 3 (Water Trading with CCWA Agencies):** This alternative would consider acquisition of unused capacity in the State Water Pipeline (SWP) from one or more CCWA project participants, including acquiring exchange water from one or more CCWA project participants. Water could be provided via a turnout along the State Water Pipeline within the NCSO boundary. This water would then either be delivered directly to the NCSO water system, or indirectly via aquifer storage and recovery.

As new construction activities would be minimal with this alternative, agency jurisdictional issues would be less than other alternatives. The use of a CCWA interconnection at the Tefft Street site may require a pipeline crossing at Nipomo Creek. If it can be determined that creek and wetland crossings can be avoided, USACE, RWQCB, and CDFG permits would not be required. Furthermore, impacts to special-status wildlife and plants could be minimized if construction is limited to disturbed and developed areas. NOAA Fisheries most likely will not be a key permitting agency under this alternative provided that surface water flows within the Santa Maria River are not affected. Existing fish passage barriers in Nipomo Creek have almost eliminated the likelihood of steelhead in Nipomo Creek. A Caltrans encroachment permit would be required for a pipeline crossing at Highway 101, if required.

Recent litigation regarding the State Water Project's Harvey O. Banks intake facility have included the judge's threat to require the California Department of Water Resources (DWR) to stop pumping water from the delta. The main issue centers around fish takes that are have not been permitted by the USFWS and NOAA Fisheries under the Endangered Species Act. It is Padre's understanding that CDFG and DWR are in negotiations with NOAA Fisheries and the USFWS which may result in an agreement being enacted to allow continued water withdrawals from the delta area with allowed incidental take of fish species.

**Alternative No. 4 (Santa Maria Groundwater):** This alternative would include the development of wells at either the Hutton Road area or at the Bonita well site to extract groundwater, which then would be conveyed to NCSO through a pipeline. Selection of one of the seawater or cooling water alternatives will require review and approval of a discretionary development permit by the County of San Luis Obispo. Pipeline facilities associated with any of the options would likely require permits from the USACE, RWQCB, and CDFG for any pipeline creek crossings. A Caltrans encroachment permit would be required for pipeline crossings at Highway 101, if crossed. NOAA Fisheries most likely will not be a key permitting agency under this alternative provided that surface water flows within the Santa Maria River are not affected. Existing fish passage barriers in Nipomo Creek have almost eliminated the likelihood of steelhead in Nipomo Creek.

**Alternative No. 5 (Groundwater Recharge from Wastewater Treatment Facility):**

This alternative would include the construction groundwater recharge facilities within a specified area where groundwater depressions are known. This alternative would require a discretionary permit from the County of San Luis Obispo for the construction of water transmission and disposal facilities. It is anticipated that pipeline alignments associated with this alternative could be designed to avoid wetlands and sensitive habitat areas through environmental planning and site design. It is also anticipated that wetland and creek pipeline crossings would not be required for this alternative. A WDR permit modification from the RWQCB would be required for the disposal of treated wastewater at the proposed recharge facilities. No Caltrans encroachment permit would be required if conveyance facilities did not cross Highways 1 or 101.

**Alternative No. 6 (Treated Water Exchange with Agricultural Water users).** This alternative would include an exchange of treated wastewater for agricultural water within a specified area where groundwater depressions are known. This alternative would require a discretionary development permit from the County of San Luis Obispo for the construction of water transmission and storage facilities. It is anticipated that pipeline alignments associated with this alternative could be designed to avoid wetlands and sensitive habitat areas through environmental planning and site design. It is also anticipated that wetland and creek pipeline crossings would not be required for this alternative. A WDR permit modification from the RWQCB would be required for the beneficial re-use of treated wastewater at the proposed agricultural lands. No Caltrans encroachment permit would be required if conveyance facilities did not cross Highways 1 or 101.

## **4.2 GENERAL RECOMMENDATIONS**

**Biological Resources.** The preliminary review of the project alternatives identified potential constraints related to habitat for protected species within the Oso Flaco Lake, Nipomo-Guadalupe Dunes and other wetland/creek areas in the project area. The following are recommendations to minimize impacts to biological resources:

- Complete required CRLF protocol-level surveys during the CRLF breeding season (January 1 through June 30) to identify all known populations of CRLF within the limits of the project boundary and nearby areas. This would be accomplished once project alternative details and engineering specifications can clearly define areas of potential impact. As an example, potential impacts to the CRLF and associated habitat areas can be avoided and/or minimized through additional pipeline-route deviations and/or adjustments.
- Where necessary, the use of HDD construction methods across creeks and streams would minimize impacts to wetland/ jurisdictional waters and special-status species with the potential to occur in the area.
- Rare plant species (e.g. Nipomo Mesa Lupine, La Graciosa Thistle, Dune Larkspur) are located within the vicinity of Oso Flaco Lake and the Conoco-Phillips Refinery. Coastal Dune Scrub, considered a sensitive habitat, is common in this area. Botanical surveys may be needed to determine the likelihood of impacts within any final selected pipeline alignments, or other treatment plant facilities. Impacts to rare

plants may be avoided through route-deviations or other strategic placement as feasible, and/or through seed collection and restoration, as necessary.

**Wetlands/Waters of the U.S.** A high-level preliminary review of the project alternatives and site survey(s) conducted to date identified potential constraints related to regulated waters of the U.S. and wetlands. Following are recommendations to minimize impacts to wetlands and Waters of the U.S.:

- Where necessary, the use of HDD construction methods across creeks and streams would minimize impacts to wetland/ jurisdictional waters and special-status species with the potential to occur in the area.
- Whenever possible, limit construction activities to within previously disturbed or developed areas to avoid impacting sensitive habitat areas. A wetland delineation may be required to determine the likelihood of impacts to identified wetlands within final selected pipeline alignments and other impacted areas.
- “Frac-outs”, or the loss of drilling fluids to the surrounding environment, and potential release of drilling mud into sensitive aquatic areas, are considered serious offenses by regulatory agencies. The potential for “frac-outs” should be minimized by incorporation of engineering and geologic information and development of a drilling and drilling fluid monitoring program that considers the existing geological conditions.
- Creek crossings and/or HDD operations may be limited by CDFG, RWQCB, and NOAA Fisheries to April 15 through October 15 to avoid impacts to water quality and associated sensitive species.

**Cultural Resources.** Alternatives involving construction activities and placement of project-related infrastructure (i.e. pipelines, tanks, treatment plants) would require evaluation and analysis of the potential for effect on culturally-sensitive resources. Alternatives would require delineation of pipeline routes and placement of project facilities prior to implementing cultural records searches and visual survey.



Table 2. Matrix of Required Permits by Alternative

Alternatives/Options	USACE - 404/D Permit	USFWS - Section 7	NOAA Fisheries - Section 7	California Coastal Commission	California State Lands Commission	OPFG-SAA	Regional Water Quality Control Board (RWQCB) - 401 Cont.	RWQCB - NPDES/MS4	RWQCB - SWPPP	DHS - Water Supply Permit	Caltrans - Encroachment Permit	County or State Lands Office Permits	SLO APD - Authority to Construct	SLO Environmental Health	Relative Priority of Permitting (Low to High)	Biological Resource Mitigation Required (High/Low)	Permitting Time Requirement
Alternative 1 – Seawater/Cooling Water Treatment	<input checked="" type="checkbox"/>	<input checked="" type="checkbox"/>	<input checked="" type="checkbox"/>	<input checked="" type="checkbox"/>	<input checked="" type="checkbox"/>	<input checked="" type="checkbox"/>	<input checked="" type="checkbox"/>	<input checked="" type="checkbox"/>	<input checked="" type="checkbox"/>	<input checked="" type="checkbox"/>	<input checked="" type="checkbox"/>	<input checked="" type="checkbox"/>	<input checked="" type="checkbox"/>	<input checked="" type="checkbox"/>	H	H	24-36 mos.
Alternative 2 – Oso Flaco Agricultural Water	<input checked="" type="checkbox"/>	<input checked="" type="checkbox"/>	<input checked="" type="checkbox"/>	<input checked="" type="checkbox"/>	<input checked="" type="checkbox"/>	<input checked="" type="checkbox"/>	<input checked="" type="checkbox"/>	<input checked="" type="checkbox"/>	<input checked="" type="checkbox"/>	<input checked="" type="checkbox"/>	<input checked="" type="checkbox"/>	<input checked="" type="checkbox"/>	<input checked="" type="checkbox"/>	<input checked="" type="checkbox"/>	H	H	24-36 MOS
Alternative 3 – Water trading with CCWA agencies	<input checked="" type="checkbox"/>	<input checked="" type="checkbox"/>	<input checked="" type="checkbox"/>	<input type="checkbox"/>	<input type="checkbox"/>	<input checked="" type="checkbox"/>	<input checked="" type="checkbox"/>	<input type="checkbox"/>	<input checked="" type="checkbox"/>	<input checked="" type="checkbox"/>	<input checked="" type="checkbox"/>	<input checked="" type="checkbox"/>	<input type="checkbox"/>	<input type="checkbox"/>	L	L	12-18 MOS
Alternative 4 – Santa Maria Groundwater	<input checked="" type="checkbox"/>	<input checked="" type="checkbox"/>	<input checked="" type="checkbox"/>	<input type="checkbox"/>	<input type="checkbox"/>	<input checked="" type="checkbox"/>	<input checked="" type="checkbox"/>	<input type="checkbox"/>	<input checked="" type="checkbox"/>	<input checked="" type="checkbox"/>	<input type="checkbox"/>	<input checked="" type="checkbox"/>	<input type="checkbox"/>	<input checked="" type="checkbox"/>	L	L	12-24 MOS
Alternative 5 – Groundwater Recharge with Treated Water from Southland WWTF	<input type="checkbox"/>	<input type="checkbox"/>	<input type="checkbox"/>	<input type="checkbox"/>	<input type="checkbox"/>	<input type="checkbox"/>	<input type="checkbox"/>	<input checked="" type="checkbox"/>	<input checked="" type="checkbox"/>	<input checked="" type="checkbox"/>	<input type="checkbox"/>	<input checked="" type="checkbox"/>	<input type="checkbox"/>	<input checked="" type="checkbox"/>	L	L	12 MOS
Alternative 6 – Agricultural Water Exchange	<input type="checkbox"/>	<input type="checkbox"/>	<input type="checkbox"/>	<input type="checkbox"/>	<input type="checkbox"/>	<input type="checkbox"/>	<input type="checkbox"/>	<input checked="" type="checkbox"/>	<input checked="" type="checkbox"/>	<input checked="" type="checkbox"/>	<input type="checkbox"/>	<input checked="" type="checkbox"/>	<input type="checkbox"/>	<input type="checkbox"/>	L	L	12 MOS





## 5.0 REFERENCES

- Cachuma Resource Conservation District and the Dunes Center. 2004. Draft Nitrate and Sediment Assessment, Oso Flaco Watershed, San Luis Obispo County, California. Report prepared for California Regional Water Quality Control Board, Central Coast Region, August.
- California Natural Diversity Database, 2006. Rarefind 3 Query. California Department of Fish and Game. Sacramento, Ca.
- County of San Luis Obispo, Safety Element, 1998.
- Cowardin, Lewis M., V. Carter, F.C. Golet, and E.T. LaRoe, 1979. *Classification of Wetlands and Deepwater Habitats of the United States*. U.S. Fish and Wildlife Service. Washington, D.C.
- Douglas Wood and Associates, Draft Environmental Impact Report for Nipomo Community Services District Waterline Intertie Project, May 2006.
- Central Coast Regional Water Quality Control Board, 2006. Phase Four: Project Analyses, Final Preliminary Project Report, Total Maximum Daily Loads for Nitrate and Ammonia in Santa Maria River and Oso Flaco Creek watersheds, Santa Barbara and San Luis Obispo Counties, California. December 5.
- U.S. Army Corps of Engineers. 2001. Memorandum: Supreme Court Ruling Concerning CWA Jurisdiction over Isolated Waters. January 19, 2001. Washington, D.C.
- U.S. Fish and Wildlife Service (USFWS). 2005. *Revised guidance on site assessments and field surveys for the California red-legged frog*. U.S. Fish and Wildlife Service, Portland, Oregon. 26.

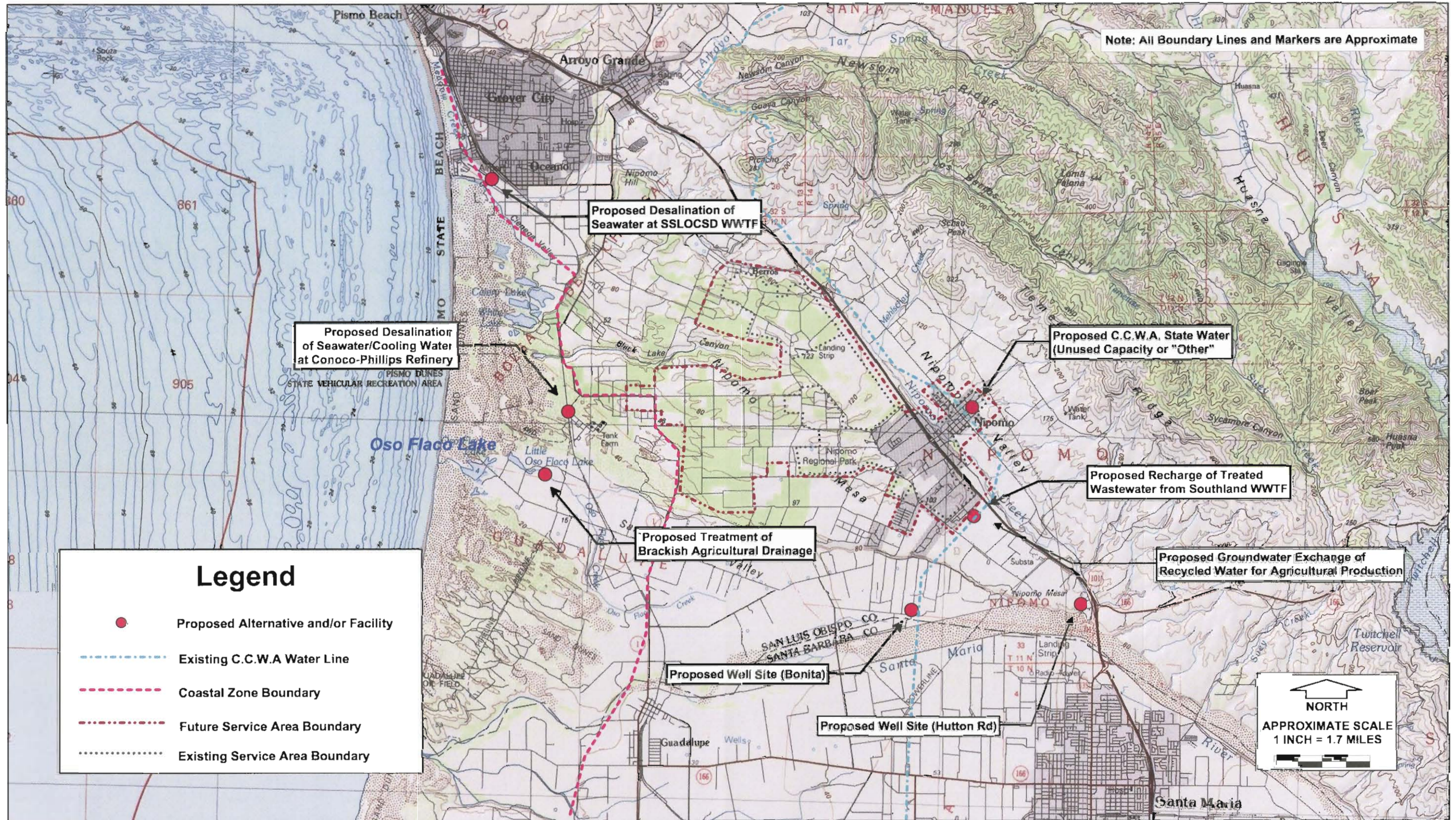

Source: Boyle Engineering; TOPO! © 2001 National Geographic Holdings (www.topo.com)



NCSD - Supplemental Water Supply  
 Alternatives Constraints Analysis

PROJECT ALTERNATIVES LOCATION MAP

FIGURE 1

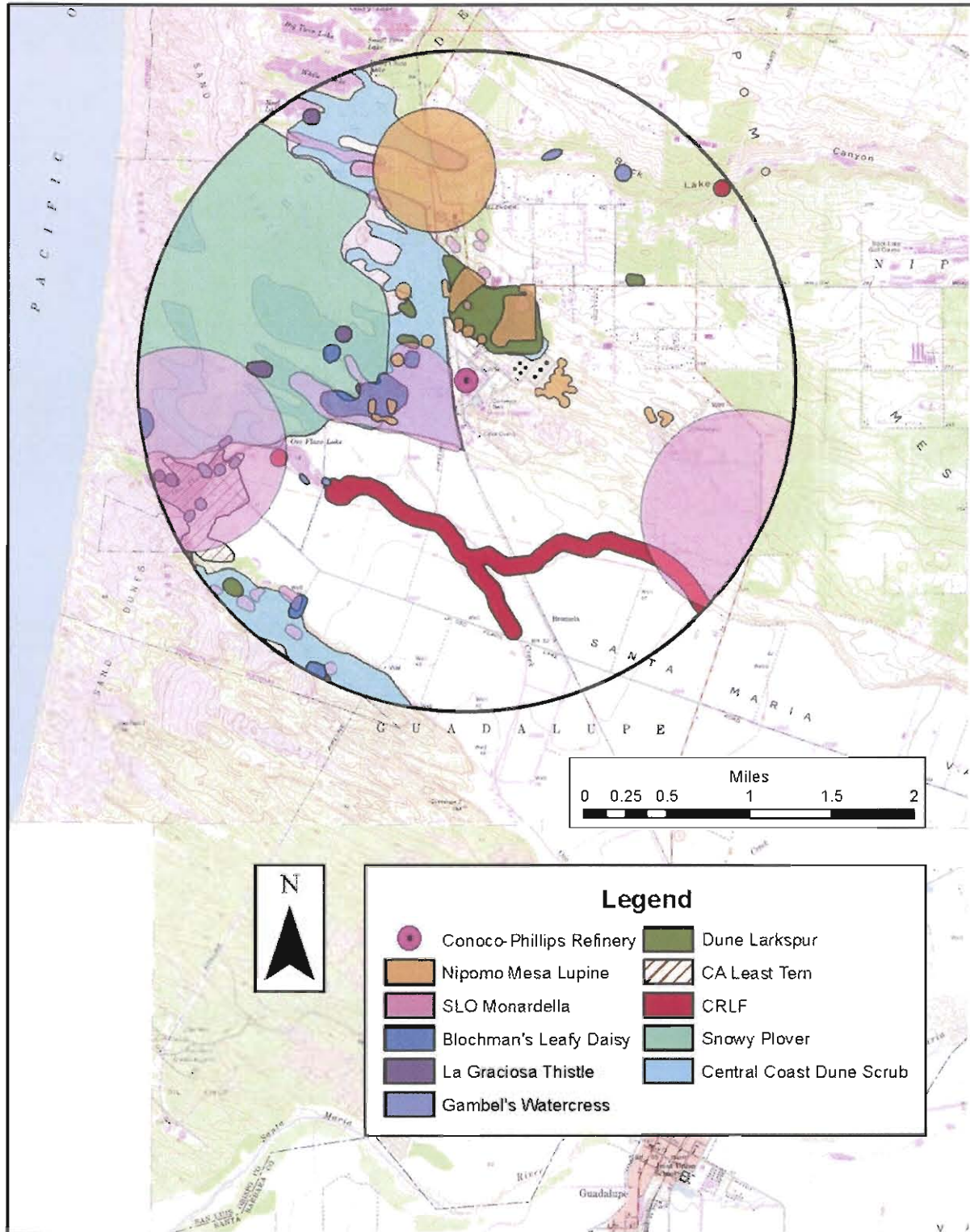

Source: CNDDDB RareFind 3



NCSD - Supplemental Water Supply  
 Alternatives Constraints Analysis

**FIGURE 2**

**Special-Status Species Occurrences in  
 2-Mile Radius of Conoco-Phillips Refinery**

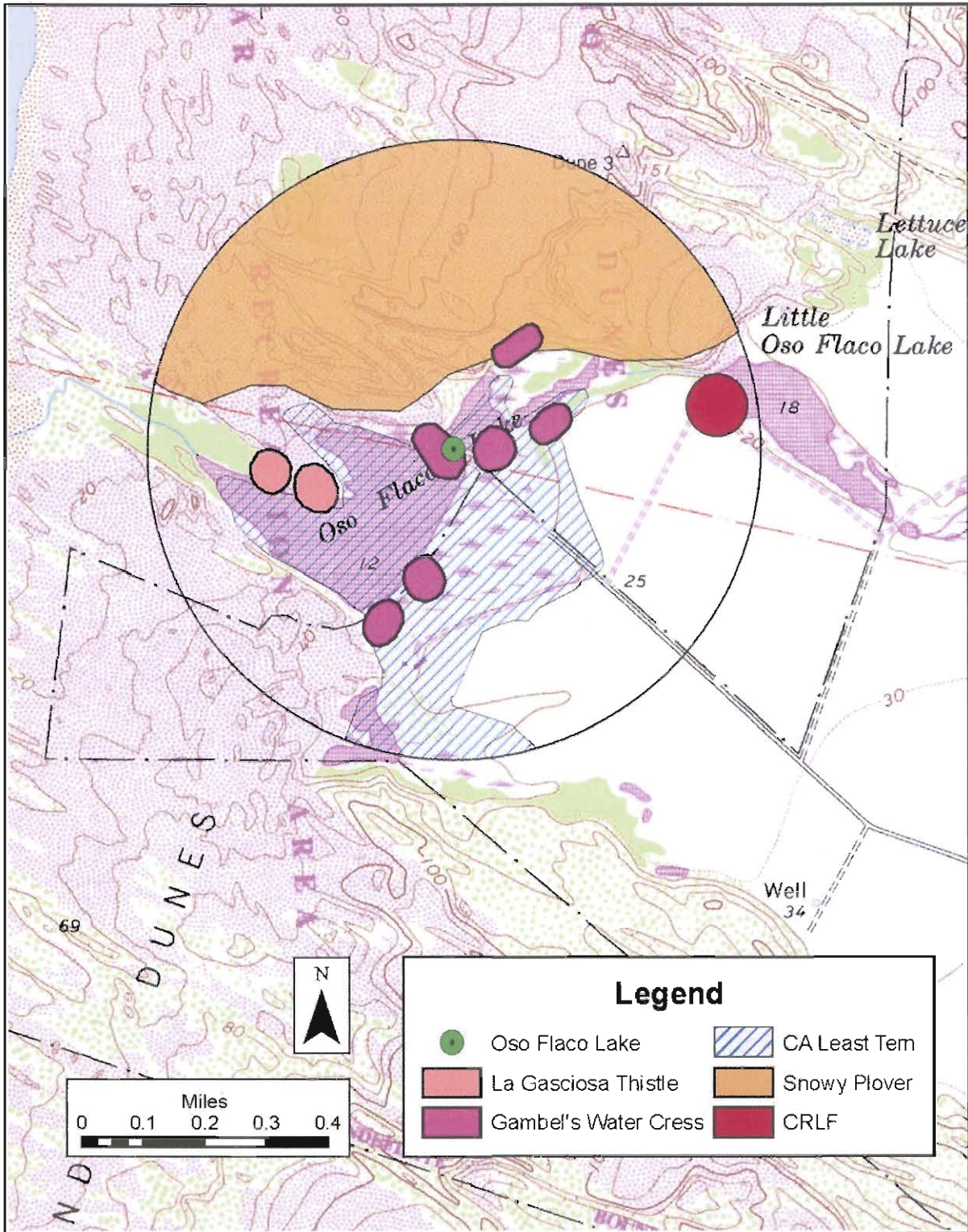

Source: CNDDB RareFind 3



NCSD - Supplemental Water Supply  
 Alternatives Constraints Analysis

**FIGURE 3**

**Special-Status Species Occurrences  
 in 0.5-mile Radius of Oso Flaco Lake**

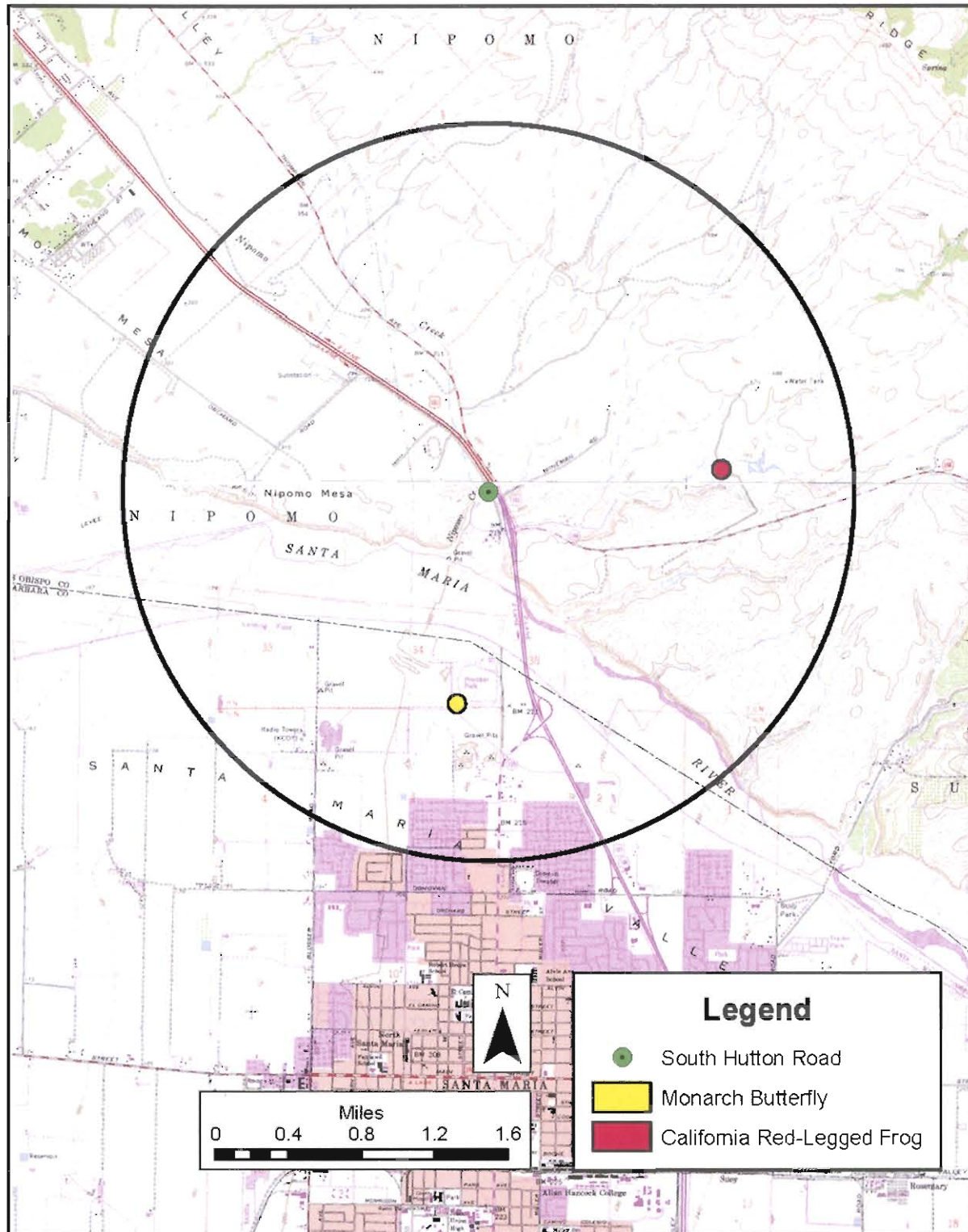

Source: CNDDDB RareFind 3



NCSD - Supplemental Water Supply  
Alternatives Constraints Analysis

**FIGURE 4**  
**Special-Status Species Occurrences**  
**in 2-Mile Radius of South Hutton Road**

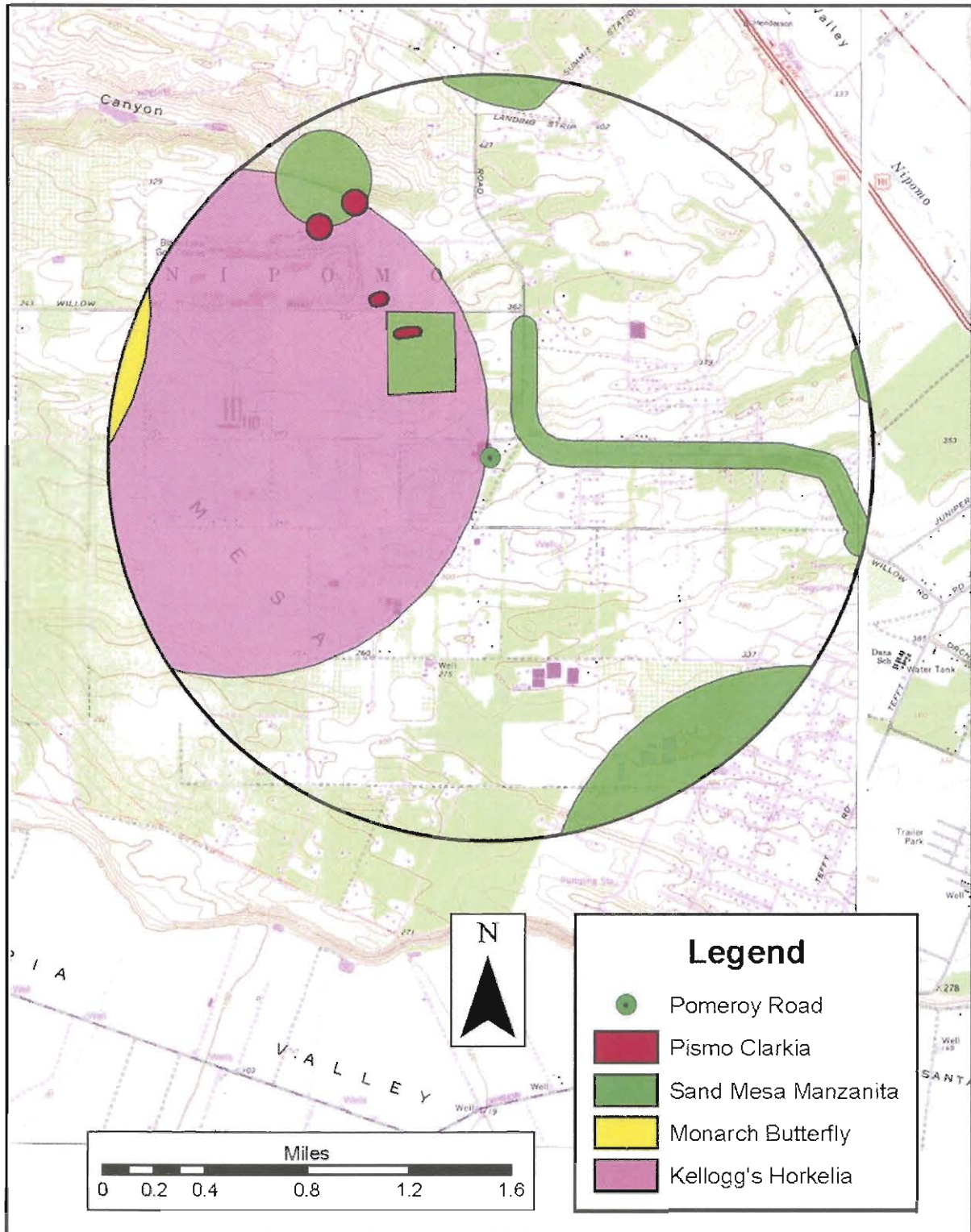

Source: CNDDDB RareFind 3



NCSD - Supplemental Water Supply  
Alternatives Constraints Analysis

FIGURE 5

Special-Status Species Occurrences  
in 2-Mile Radius of Pomeroy Road

# **Evaluation of Desalination as a Source of Supplemental Water**

## **ADMINISTRATIVE DRAFT Technical Memorandum 2**

### **Work Plan for Project Implementation**

---

#### **Nipomo Community Services District**

Board of Directors

President: Michael Winn  
Vice President: Larry Vierheilig  
Cliff Trotter  
Ed Eby  
Jim Harrison

General Manager

Bruce Buel

#### **Boyle Engineering Corporation**

Project Manager  
Project Engineer

Michael Nunley, PE  
Malcolm McEwen, PE

September 28, 2007

**BOYLE**

1194 Pacific Street, Suite #204

San Luis Obispo, CA 93401

---



# Table of Contents

Executive Summary .....	1
Purpose .....	1
Project Development Options .....	1
Conclusions and Recommendations .....	2
Proposed Work Plan.....	3
Proposed Schedule .....	4
Proposed Budget .....	4
Section 1 Introduction and Summary .....	5
Objectives.....	5
Original Scope of Work – Evaluation of Supplemental Water Alternatives .....	5
Scope of Work – Technical Memorandum 2 (Work Plan for Desalination Option) .....	7
Project Development Options .....	8
Outline of Project Approach .....	9
Section 2 Impact Studies.....	10
Overview of Impact Studies.....	10
Purpose.....	10
Goals .....	10
Regulatory Agencies .....	10
Information Needs.....	11
Draft Monitoring Guidelines from the Monterey Bay National Marine Sanctuary .....	11
Monterey County Experience – Coastal Water Project (CWP).....	13
Orange County Experience – Dana Point Ocean Desalination Project .....	14
Implications for Proposed Nipomo CSD Desalination Project.....	16

Terrestrial and Freshwater Impact Study .....16

    Existing Information .....16

    Work Plan .....17

Marine Impact Study.....17

    Existing Information .....17

    Work Plan .....17

Cultural Resource Impact Study .....18

    Existing Information .....18

    Work Plan .....18

Section 3 Feasibility Studies.....19

    Hydrogeologic Feasibility Study.....19

        Conceptual Intake Options.....19

        Conceptual Discharge Options .....19

        Preliminary Intake and Discharge Locations .....19

        Summary of Existing Information .....20

        Purpose and Goals.....24

        Phase 1 Work Plan .....24

        Phase 2 Work Plan .....25

    Intake Feasibility Study .....26

        Purpose.....26

        Goals .....26

        Work Plan .....26

    Discharge Feasibility Study .....27

        Purpose.....27

        Goals .....27

        Work Plan .....27

    Treatment Feasibility (Pilot) Study.....28

        Purpose.....28

Goals .....28

Work Plan .....28

Section 4 Preliminary Engineering .....29

    Purpose .....29

    Goals .....29

    Approach .....29

Section 5 CEQA/NEPA Process .....30

    Purpose .....30

    Goals .....30

    CEQA Compliance Approach .....30

    NEPA Compliance Approach .....30

Section 6 Public Outreach .....32

    Purpose .....32

    Goals .....32

    Work Plan .....32

Section 7 Design and Permitting .....33

    Coordination of Design and Permitting Activities .....33

    Design and Permitting Issues .....33

    California Department of Health (DHS) Issues .....35

    General Approach .....35

Section 8 Bidding and Construction .....36

    Overview .....36

    Bid-Phase Activities .....36

    Construction-Phase Activities .....36

Section 9 Schedule .....37

    Projected Schedule .....37

Section 10 Budget .....38

    Probable Cost of Implementation and Operation .....38

Phased Implementation .....39

Section 11 Conclusions and Recommendations .....40

Section 12 References.....41

Appendices.....

    Appendix A: Treatment Plant Site Options .....

    Appendix B: Environmental and Permitting Constraints Analysis.....

    Appendix C: Projected Project Schedule Detail .....

    Appendix D: Opinion of Probable Cost.....

# Executive Summary

## Purpose

The purpose of this Technical Memorandum is to provide the Nipomo Community Services District (NCSD) with a plan to implement a seawater or brackish water desalination plant capable of delivering at least 6,300 acre-feet per year of desalted water. The focus of this report is identification of several key preliminary studies which will be needed in order to build and operate a desalination facility. This plan includes the following components:

- A description of the necessary studies, a schedule for their implementation, and an opinion of their probable costs;
- Development of an overall project schedule including the impact studies, feasibility studies, preliminary engineering, design, construction, and operational testing/startup phases; and
- Establishment of a preliminary project budget, which is expected to be refined and modified significantly as the project proceeds.

## Project Development Options

Project implementation will require the following choices, among others:

- Regional partnership or District-owned project? The City of Arroyo Grande, City of Grover Beach, and Oceano Community Services District are currently starting a desalination feasibility study. They were recently awarded Proposition 50 grant funding to assist with paying for this work. Policies for developing desalination facilities (including the Monterey Bay National Estuary Program Desalination Plan) encourage regional cooperation instead of development of nearby, separate desalination facilities.
- Design-build, conventional design-bid-build, or “hybrid” approach? Some owners prefer design-build partnerships based on claims that projects can be delivered quickly and less expensively than conventional design-bid-build projects. Variations of design-build projects can include financing and operation of the system in order to allow owners to minimize capital costs by spreading payments over a specified period. The conventional design-bid-build approach may be preferred because it typically results in complete design plans which are competitively bid among different contractors, encouraging competition while ensuring the client’s standards are met.
- Brackish groundwater or seawater? The hydrogeology of the coastal area between Oceano and Oso Flaco is not understood in detail. Artesian conditions have been observed near the coast, but the yield and quality of this water has not been evaluated, other than some basic mineral parameters. It is assumed that extraction of seawater would not be prohibited or limited by the Santa Maria Groundwater Litigation, but brackish water may be affected. However, use of seawater is typically more expensive, because because the higher salt content requires greater power usage per amount of product water and results in greater potential impacts for brine disposal.

## Conclusions and Recommendations

The District Board should consider the following

- As presented in this Work Plan, implementation of a desalination plant may require approximately \$79 M on a present worth basis (not including cost escalation, which is included in the cost opinions and cashflow analyses presented in this study). These estimates are considered preliminary, and may change significantly as the project proceeds.
- Additional costs include the distribution system improvements for the long-term Supplemental Water Project as recommended in the draft Water Master Plan.
- The implementation period may take over 8 years.
- While other seawater desalination projects similar in size to the District's project, or larger (such as the Monterey Bay, or Dana Point facilities) have put significant time, effort, and expense into permitting and initial studies for a desalination project, neither projects have received all their permits and they are still in the pilot testing and feasibility study phases.
- Little is known about the hydrogeologic characteristics of the areas proposed for subsurface intakes and discharges. Therefore, it is unknown whether these structures will be feasible.
- Although the South SLO County desalination study participants have not begun implementation of a desalination project, there may be considerable pressure from regulatory agencies to form a regional partnership in lieu of developing two (2) desalination projects approximately 6-7 miles apart.

Boyle recommends proceeding with the following tasks, in order to begin implementation of a desalination project:

- Begin initial funding analysis of this project, in order to assess developer impact fees, water rates, and financial responsibility of project partners (other Nipomo Mesa water purveyors);
- Conduct an initial meeting with the San Luis Obispo County planning department, and other resource agency representatives, in order to begin identifying permitting issues and processes;
- Contact PG&E and discuss availability of power at the potential treatment plant sites, in order to identify the schedule and cost to upgrade electrical service to these locations (if required);
- Meet with the South SLO County desalination study partners to discuss potential for working together; and
- Begin searching for appropriate grant funding sources.

**Proposed Work Plan**

The following flow chart shows the inter-relationships between the various studies and plans described in this work plan.

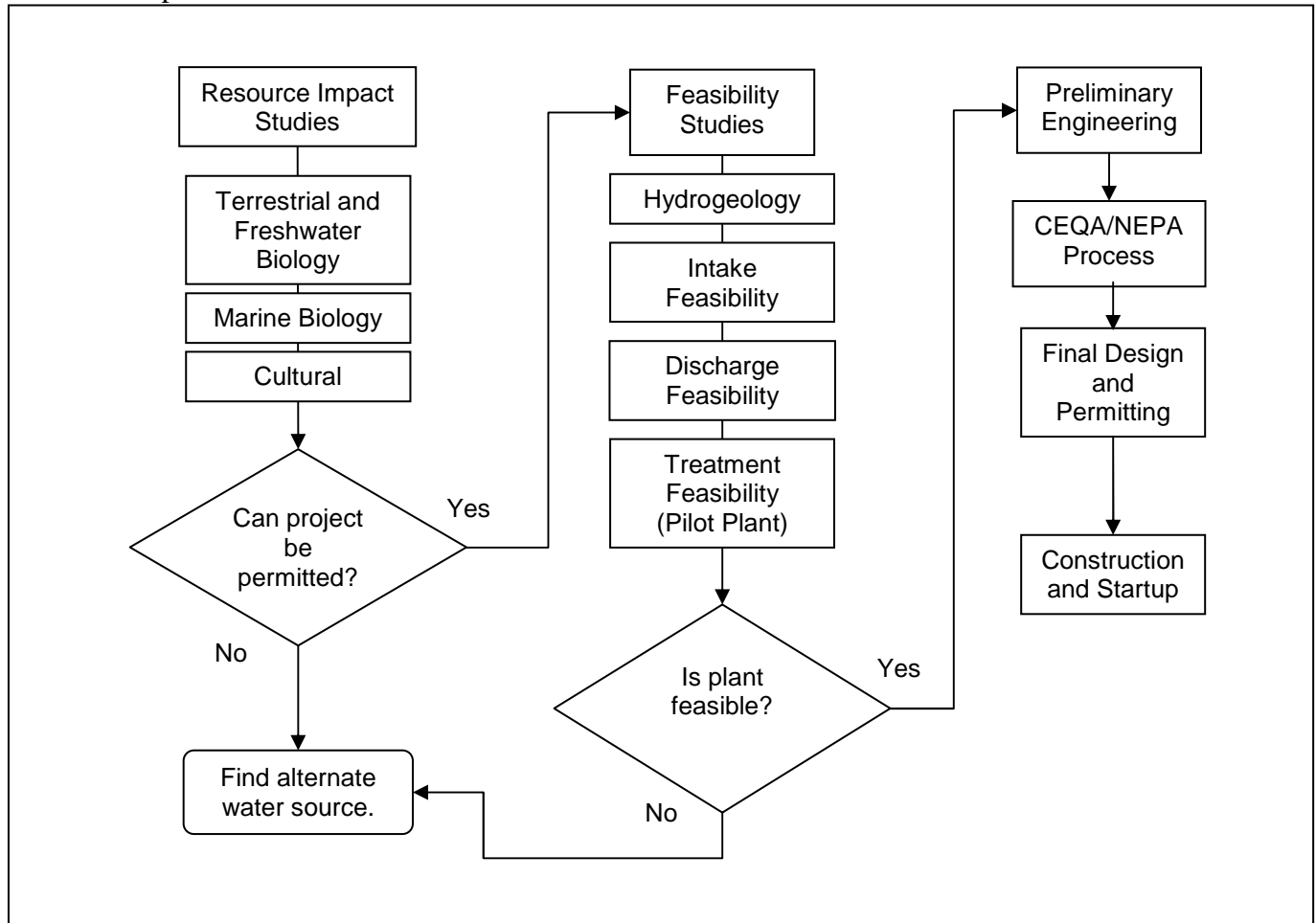

### Proposed Schedule

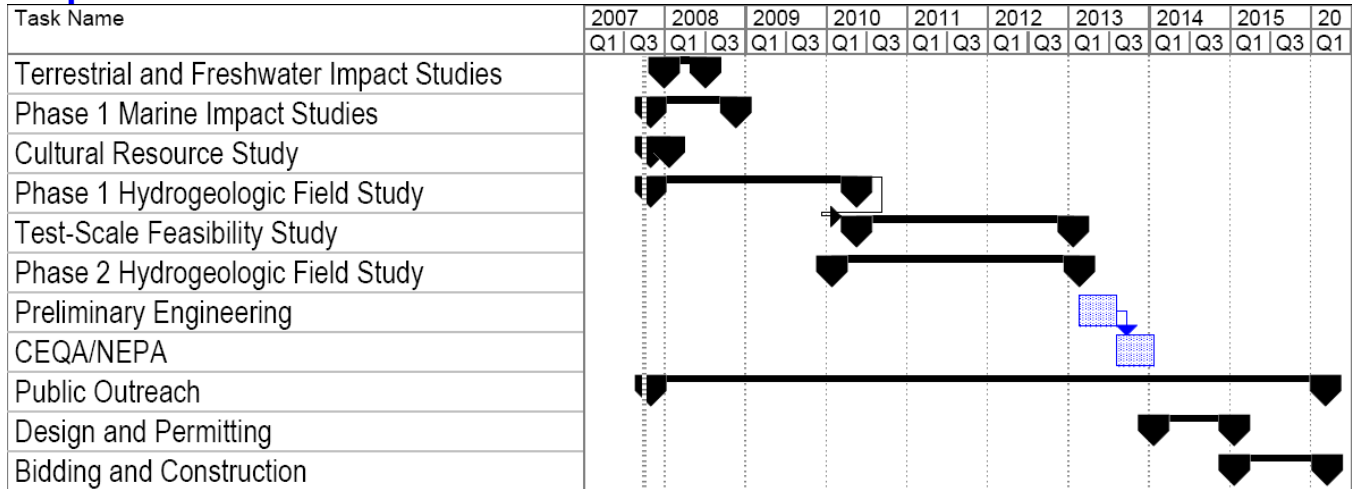

### Proposed Budget

Task	Probable Cost	% of Total
Terrestrial and Freshwater Impact Studies	\$ 440,000	0.8%
Phase 1 Marine Impact Studies	250,000	0.4%
Cultural Resource Study	66,000	0.1%
Phase 1 Hydrogeologic Field Study	360,000	0.7%
Test-Scale Feasibility Study	2,320,000	4.2%
Phase 2 Hydrogeologic Field Study	180,000	0.3%
Preliminary Engineering	210,000	0.4%
CEQA/NEPA	240,000	0.4%
Public Outreach	1,310,000	2.3%
Design and Permitting	3,870,000	5.1%
Construction	67,940,000	82.5%
Project Management	1,500,000	2.7%
<b>Total before Escalation</b>	<b>\$ 78,700,000</b>	<b>100.0%</b>
Cost Escalation	19,510,000	
<b>Total with Escalation</b>	<b>\$ 98,210,000</b>	



# Section 1 Introduction and Summary

## Objectives

The purpose of this Technical Memorandum is to provide the Nipomo Community Services District (NCSD) with a plan to implement a seawater or brackish water desalination plant capable of delivering at least 6,300 acre-feet per year of desalted water. If the plant were to run at a constant rate, it would need to produce at least 5.6 MGD (million gallons per day) or 3900 gpm (gallons per minute.) Higher design rates could be considered to allow for periodic maintenance or variable production rates, but that level of detailed evaluation is beyond the conceptual evaluations presented herein.

The focus of this report is identification of several key preliminary studies which will be needed in order to build and operate a desalination facility. This plan includes the following components:

- A description of the necessary studies, a schedule for their implementation, and an opinion of their probable costs;
- Development of an overall project schedule including the impact studies, feasibility studies, preliminary engineering, design, construction, and operational testing/startup phases; and
- Establishment of a preliminary project budget, which is expected to be refined and modified significantly as the project proceeds.

The goals of this Technical Memorandum are to:

- Provide schedule and budget information sufficient for preliminary financial planning;
- Identify typical project constraints for focusing and scheduling study efforts; and
- Develop a work plan for project implementation.

## Original Scope of Work – Evaluation of Supplemental Water Alternatives

On February 8, 2007, the NCSD authorized Boyle to perform an evaluation of options to provide supplemental water to the District. The initial scope of work was intended to compare various alternatives to the NCSD Waterline Intertie Project, which was described in a draft Technical Memorandum by Boyle in November, 2006. The District Board decided the project cost (between \$24 and 26 M) was prohibitive, and other options should be explored.

Boyle's original scope of services (including Contract Amendment dated April 6, 2007) included a constraints analysis and preliminary feasibility study of several alternatives including:

- acquiring water from the Central Coast Water Authority (CCWA) via the CCWA/State Water Pipeline that traverses NCSD;
- Santa Maria Valley groundwater at various well sites;
- extension of the Nacimiento Water Pipeline Project;

- brackish agricultural drainage from Oso Flaco Lake, located to the west of Guadalupe;
- groundwater recharge or direct irrigation reuse of treated wastewater; and
- seawater or brackish water desalination.

The work was organized into three tasks:

- Task 1 – Constraints analysis;
- Task 2 – Detailed evaluation of CCWA and Santa Maria Valley groundwater alternatives; and
- Task 3 – Detailed evaluation of extension of the Nacimiento Water Pipeline Project, brackish agricultural drainage from Oso Flaco Lake, groundwater recharge of treated wastewater, and direct reuse of treated wastewater.

Boyle submitted a draft of Task 1 which concluded the following:

- CCWA alternatives would likely require approval from City of Santa Maria and CCWA member agencies, but could be the least expensive alternative if the SWP pipeline was used to deliver City water in lieu of the Waterline Intertie Project (per the November, 2006, draft Preliminary Engineering Memorandum);
- Nacimiento Water Project Extension, Oso Flaco Lake, and Santa Maria Valley groundwater have significant “fatal flaws”; and
- Desalination requires a significant, long-term investment for studies and coordination with regulatory agencies, and had high capital and operation and maintenance cost compared to the other alternatives, but is considered a highly reliable water supply. It was the only water supply considered in this study which could reliably deliver up to 6,300 acre-feet per year (AFY), which is projected as future water demand per the District’s draft Water Master Plan.

As a result of these findings, Boyle was authorized to redirect its study efforts. Instead of producing TMs 2 and 3 (as described above), Boyle revised the scope to produce TMs for two water supply projects:

- Short Term: CCWA/City of Santa Maria turnout near Tefft and Thompson to deliver City water directly to Nipomo distribution system (up to 3,000 AFY); and
- Long Term: Desalination of brackish water or seawater (up to 6,300 AFY).

This TM is the deliverable for the “long-term” water supply alternative, brackish or seawater desalination.

## **Scope of Work – Technical Memorandum 2 (Work Plan for Desalination Option)**

The Scope of Work for this deliverable included the following tasks. The Scope was further defined in a letter to Bruce Buel dated August 6, 2007.

Task 201 – Coordination with Regional Water Quality Control Board, California Department of Health Services (DHS), San Luis Obispo County Planning Department, South SLO County Sanitation District, and Nipomo Refinery Staff

Boyle will plan and attend coordination meetings with Nipomo CSD staff and one or more of the entities noted above. The purpose of the meetings is to establish significant permitting tasks and milestones, as well as to obtain input from those agencies early in the project development process.

In the 8/6/07 letter, it was decided Boyle’s study would assume the CSD was developing this project without partnering with South SLO County Sanitation District in a regional desalination project, because the agencies had not yet proceeded with their feasibility study (expected to begin in October, 2007).

Task 202 – Seawater / Brackish Water Intake Options

Boyle will evaluate potential sites for an intake, assuming that beach wells are the most viable option from permitting and cost perspectives. We will identify up to three (3) sites and recommend steps/objectives for a hydrogeological study to define intake design parameters.

Task 203 – Discharge Options

Boyle will review potential effluent discharge options, including sharing the Nipomo Refinery outfall, constructing a new ocean outfall, and subsurface discharge. Boyle will recommend one or more of the three options for further evaluation, and will recommend steps/objectives for defining design parameters.

Task 204 – Treatment Site Options

Boyle will evaluate up to three (3) potential treatment plant sites, including property adjacent to Nipomo Refinery, South County Sanitation District (shared facility), and another site to be identified by the District. It is assumed the District will be actively involved in identifying sites, and that Boyle will determine property ownership from tax assessor records at the County offices.

### Task 205 – Project Budget

After completing the Tasks listed above, Boyle will work with the District to define a budget for planning studies, preliminary engineering, design, permit negotiation, and construction.

### Task 206 – Implementation Schedule

Boyle will develop a schedule for implementing the desalination project. This will include appropriate tasks for permitting, design, construction, pilot-testing, performance testing, and startup/commissioning.

## Project Development Options

Project implementation will require the following choices, among others:

- Regional partnership or District-owned project? The City of Arroyo Grande, City of Grover Beach, and Oceano Community Services District are currently initiating a desalination feasibility study. They were recently awarded Proposition 50 grant funding to assist in financing this work. Policies for developing desalination facilities (including the Monterey Bay National Estuary Program Desalination Plan) encourage regional cooperation instead of development of nearby, separate desalination facilities.
- Design-build, conventional design-bid-build, or “hybrid” approach? Some owners prefer design-build partnerships based on claims that projects can be delivered quickly and less expensively than conventional design-bid-build projects. Variations of design-build projects can include financing and operation of the system in order to allow owners to minimize capital costs by spreading payments over a specified period. The conventional design-bid-build approach may be preferred because it typically results in complete design plans which are competitively bid among different contractors, encouraging competition while ensuring the client’s standards are met.
- Brackish groundwater or seawater? The hydrogeology of the coastal area between Oceano and Oso Flaco is not understood in detail. Artesian conditions have been observed near the coast, but the yield and quality of this water has not been evaluated, other than some basic mineral parameters. It is assumed that extraction of seawater would not be prohibited or limited by the Santa Maria Groundwater Litigation, but brackish water may be affected. However, use of seawater is typically more expensive, because the higher salt content requires greater power usage per amount of product water and results in greater potential impacts for brine disposal.

It is recommended that the District address these decisions early in the project development process. Based on Boyle’s conversations and meetings with District staff, it is assumed that the project will be District-owned, will follow a conventional design-bid-build approach, and will treat seawater. It is further assumed that Boyle will assist the District in trying to attract partners in the desalination project.

### Outline of Project Approach

The following flow chart shows the inter-relationships between the various studies and plans described in this work plan.

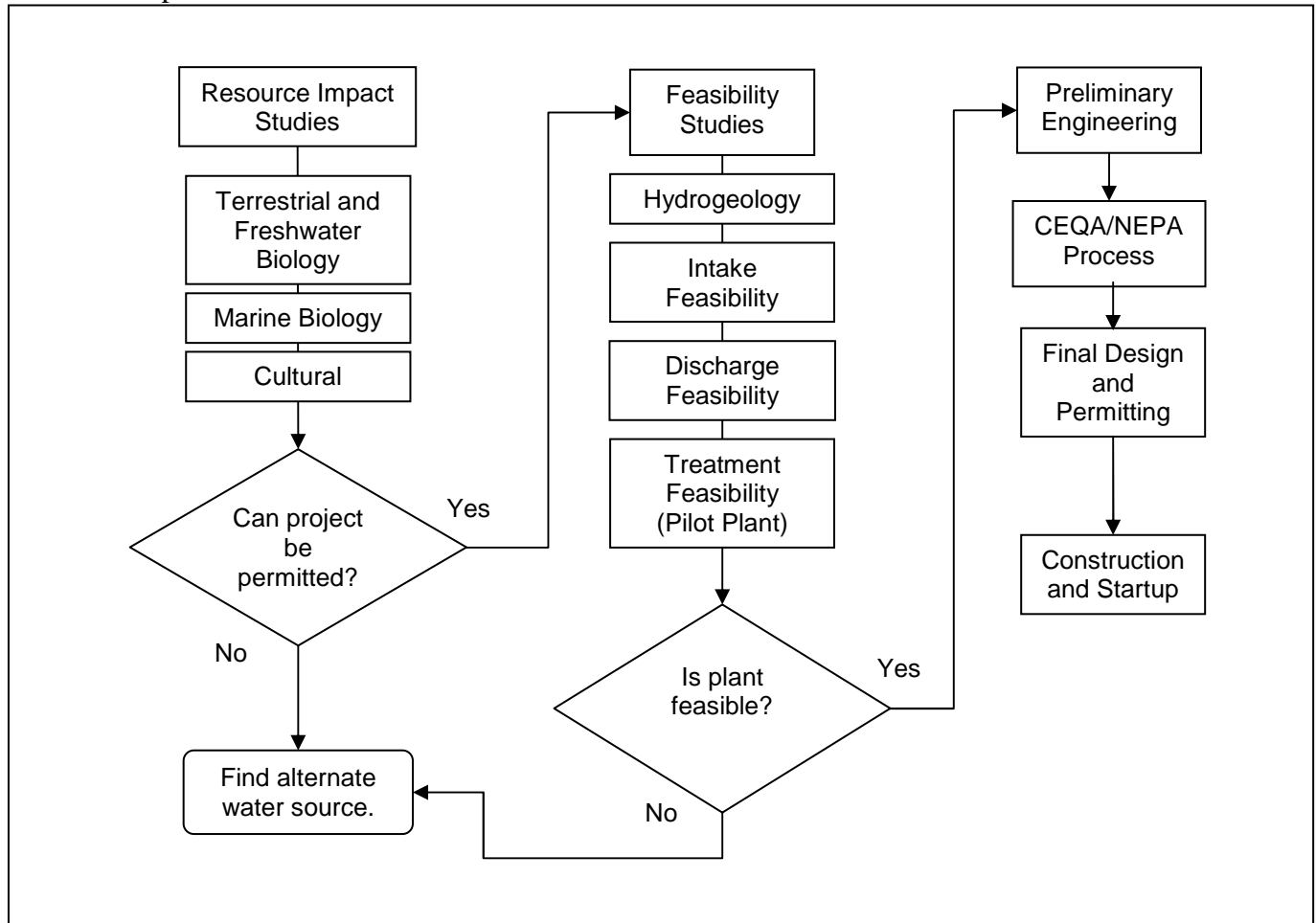

# Section 2 Impact Studies

## Overview of Impact Studies

The following sections describe the impact studies that would need to be completed prior to initiation of feasibility studies and project implementation.

Because the site of the proposed desalination facility and the alignments for the intake, discharge, and product pipelines have not been selected, it may be more economical if these resource impact studies are conducted in two phases: one phase for the areas to be impacted by the feasibility studies, and another phase for the areas to be impacted by the desalination facility and the intake, discharge, and product pipelines.

## Purpose

The purpose of these studies is to provide information that can be used to minimize impacts associated with the construction and operation of the proposed facility, and to satisfy the information needs of the regulatory agencies that have jurisdiction over the proposed project.

## Goals

The goals of these studies are to provide sufficient information to:

- Establish pre-project “baseline” conditions for long-term evaluation of project impacts and mitigation measures.
- Quantify the probable impacts of the feasibility studies.
- Quantify the probable impacts of the proposed project.
- Compare impacts of the proposed project to impacts associated with alternative projects. In these case, alternative projects would include different pipeline alignments, intake/discharge options (subsurface vs. open intake/outfall)
- Propose methods to minimize the expected impacts.
- Establish mitigation or restoration criteria.

Pertinent regulatory agencies are listed below.

## Regulatory Agencies

The following table lists the regulatory agencies that are likely to have jurisdiction over the project, and the permits or associated reviews that would be required.

**Table 2-1 Regulatory Agencies and Information Needs**

Agency	Permit Requirement
US Army Corps of Engineers (USACE)	Section 10 – Construction of structures affecting navigable waters of the U.S.
	Section 404 – Dredging and/or Filling in Waters of the U.S.
US Fish and Wildlife Service	Compliance with Endangered Species Act for USACE permitted activities
U.S. Coast Guard	May review USACE Section 10 Permit.
NOAA/National Marine Fisheries Service	Compliance with Endangered Species Act for USACE permitted activities
US Dept. of Interior	Compliance with National Historic Preservation Act
Coastal Commission	Coastal Development Permit
State Lands Commission	State Lands Lease
California Regional Water Quality Control Board	Compliance with CWA for USACE permitted activities
California Regional Water Quality Control Board	NPDES Permit for Discharge
California Department of Health Services	Domestic Water Permit
Caltrans	Encroachment Permits for facilities which cross Highway 1.
California Department of Fish and Game	Review pipeline crossings over streams.
California Office of Historic Preservation	Compliance with National Historic Preservation Act.
County of San Luis Obispo	Coastal Development and Development Permits

**Information Needs**

The information needs associated with assessing the terrestrial and freshwater impacts of the proposed project have been discussed in the *Environmental and Permitting Constraints Analysis*, included as Appendix B. The information needs associated with assessing the marine impacts of proposed desalination facilities are less well defined. However, some guidance can be derived from examining recently proposed or permitted desalination projects, as well as concerns raised by regulatory and resource-management agencies.

**Draft Monitoring Guidelines from the Monterey Bay National Marine Sanctuary**

In responding to plans to implement several desalination plants that would discharge to the Monterey Bay National Marine Sanctuary (MBNMS), in 2003 a draft “Desalination Action Plan” was developed to lay out “a framework for a regional approach to address desalination, aimed at reducing impacts to marine resources...” This draft action plan identified a need for developing a comprehensive modeling and monitoring program “to determine predicted properties of brine plume, and measure short and long term, and cumulative impacts.”

This draft action plan proposes development of minimal information needed in an application to implement a desalination facility, as follows:

1. *Initial evaluation of recreational, public use, and commercial impacts in vicinity of desalination facility*
2. *Initial monitoring to determine currents, tides, water depth and similar parameters of receiving waters*
3. *Pre-construction biological analysis with consideration of seasonal variability, of marine organisms in the affected area and control site to include indices, species richness, and abundance, along with evaluation of entrainment and impingement impacts.*
4. *Pre-construction estimation of expected brine composition, volumes, and dilution rates of the brine in the zone of initial dilution*
5. *Plan for toxicity testing of the whole effluent as an ongoing monitoring requirement.*
6. *Studies to determine properties of combined discharges (cooling water or sewage), and their effects and toxicity on local species*
7. *Post-operational monitoring of salinity in zone of initial dilution and control site, as indicator for plume spreading and dispersal, to be compared with expected results from plume and circulation modeling. If not in compliance then identify and implement corrective actions*
8. *End of pipe monitoring to verify results from expected brine composition and dilution*

In addition, this draft action plan proposes additional information requirements “for those proposed facilities that may affect sensitive wildlife habitats or may have increased or significant impacts on coastal resources” as follows:

1. *Pre-construction monitoring of affected area as well as a control site, to include sampling of water column, and sediment  
(Note: Water column sampling in this context concerns collecting biota that are found freely swimming or otherwise suspended in the water, as compared to biota that are found attached to, or buried within, bottom sediments.)*
2. *Post operational monitoring of affected area as well as a control site, to include sampling of water column and sediments, to be compared with preoperational monitoring results*
3. *Post operational monitoring of oxygen levels, turbidity, heavy metals or other chemical concentrations, with regard to water quality standards*
4. *Post operational sampling of sediments for heavy metals to monitor possible accumulation.  
(Possible bio-monitoring to sample tissues for heavy metals)*
5. *Post-operational biological analysis of marine organisms in the affected area and control site including indices, species richness, and abundance, to be compared with the pre-operational results*
6. *Monitoring of long term impacts of discharge (e.g. potential changes in species composition etc.)*



According to RWQCB staff, the MBNMS Desalination Plan provides general requirements which are expected to be very similar to any other project proposed within the Central Coast region of the State Water Resources Control Board. These requirements were assembled with input from various state and federal agencies, in order to develop a multi-agency approach to project development.

While these guidelines may not apply directly to the desalination facility proposed by the District, they may be used to develop an initial plan for assessing the marine impacts of the proposed facility, and its associated feasibility studies, as discussed below, and to develop a work plan for collecting sufficient hydrogeologic information to develop an acceptable model for assessing water-chemistry impacts.

### **Monterey County Experience – Coastal Water Project (CWP)**

According to the project's web site, "The central feature of the CWP is a proposed desalination facility in Moss Landing. But, the CWP encompasses more than desalination. The project will create a comprehensive water supply through an efficiency and demand management program, including aquifer storage and recovery in addition to desalination.

"The CWP will produce Carmel River replacement water plus water for the Seaside basin overdraft, for a total of 11,730 acre-feet per year. A proposed location for the CWP desalination facility is on the Moss Landing Power Plant (MLPP) property. The co-location of the CWP desalination facility with MLPP will not only help to conserve power, it will require no additional intake of seawater. By combining brine discharge with the power plant's cooling water, the co-location also provides dilution of the brine discharge, which is the by-product of the desalination process, and makes use of MLPP's existing outfall structure."

Initial planning and public outreach aspects of the CWP project started in early 2004. Construction of a pilot plant was initially scheduled for the summer of 2005, but was not started until June, 2007.

The Proponent's Environmental Assessment (PEA) addresses environmental impacts of the project and may be used as the basis for the CPUC's draft Environmental Impact Report (EIR). The PEA was submitted on July 14, 2005.

Numerous technical studies were produced to support the PEA. The types of studies which are pertinent to NCSD's proposal are listed below. ([http://www.coastalwaterproject.com/inc\\_pea.asp](http://www.coastalwaterproject.com/inc_pea.asp))

- Visual Impact Assessment
- Air Quality Data
- Fluid Dynamic Modeling Assessment (Ocean Impacts)
- List of Affected Property Owners
- Marine Biological Resources Assessment
- Noise Data
- Terrestrial Biological Resources Assessment
- Cultural Resources Assessment
- Preliminary Geotechnical Evaluation

- Preliminary Hazardous Materials Assessment
- Brine Disposal
- Site Assessments (3 Sites) and Comparison
- Desalinated Water Conveyance System (DWCS)
- Feasibility of Using HDD Wells for Water Supply and Brine Discharge
- HDD Well Supply Study
- System Flow Management and Hydraulics

**Orange County Experience – Dana Point Ocean Desalination Project**

Over the past five years, the Municipal Water District of Orange County (MWDOC) has investigated the feasibility of an ocean desalination facility in Dana Point, California. The MWDOC has undertaken various studies, reports, and investigations to explore the feasibility of this project. These reports are listed and summarized below.

**Table 2-2 Reports Prepared (to date) in Support of Ocean Desalination at Dana Point**

Report Title and Date	Summary
MWDOC’s Metropolitan Water District Seawater Desalination Project Agreement and Application, 2001	Application to the MWD seeking funding for a full-scale desalination project.
MWDOC Ocean Desalination Plant Feasibility Study, January 2003.	An analysis of two potential sites for an ocean desalination facility. RO membrane technology was evaluated as the most feasible desalination technology. The report included evaluation of several power supply scenarios for the RO facility. The report also compared the two sites on cost and benefit basis and provided details about concentrate discharge as well.
South Orange County Water Reliability Study, 2004	Evaluated a variety of projects including surface water storage, ocean desalination, and agency interconnection projects that could improve emergency supplies.
Horizontal Well Technology Application in Alluvial Marine Aquifers for Ocean Feedwater Supply and Pretreatment, Dana Point Ocean Desalination Project, January 2005. (Submitted to Department of Water Resources [DWR] for Proposition 50, Chapter 6 funding.)	MWDOC proposed this research and development project to advance the design and construction capabilities of horizontal/angle well technology for use as a feedwater supply system for ocean desalination plants sited near the mouths of stream or river systems.
Phase 1 Hydrogeology Investigation, Dana Point Ocean Desalination Project, October 2005	This report presents the results of the first phase of the investigation into the feasibility of developing a feedwater supply. The scope of the Phase 1 investigation included a drilling investigation and laboratory testing.
Test Slant Well Plan/Initial Study/Negative Declaration Subsurface Intake System Feasibility Investigation Test Slant Well, October 2005	MWDOC, as lead agency, with its consultants assembled project and environmental documentation to support the permitting for construction, installation, and testing of a test slant well.
Phase 2 Hydrogeology Investigation, Test Slant Well	This report documented the demonstration project and

<b>Report Title and Date</b>	<b>Summary</b>
Project, Dana Point Ocean Desalination Project, 2006	evaluated the feasibility of using a subsurface well intake system.
Water Desalination Proposal for Pilot Plant Testing and Funding, March 2006 (submitted to DWR for Proposition 50, Chapter 6 funding)	MWDOC proposed this pilot plant treatment and testing project to advance desalination treatment technologies most applicable for saltwater produced from subsurface slant wells.
Dana Point Desalination Facility Power Delivery Aesthetic Impact Mitigation Report, February 2006.	The document reviewed some of the key assumptions made in the MWDOC Ocean Desalination Plant Feasibility Study and determined that there are a variety of options that MWDOC could consider to minimize the aesthetic impacts of the project.
Hydraulic Evaluation of San Juan Creek Ocean Outfall Evaluation, 2006.	This report established the firm hydraulic capacity of the San Juan Creek Ocean Outfall.
Preliminary Assessment of Power Options for the Dana Point Ocean Desalination Project (Phase 1), 2006	In this Phase 1 report, power supply options for the project were evaluated and a wide range of potential options were identified for power requirements ranging from 12 to 20 megawatts (MW).
Subsurface System Intake Feasibility Assessment Task 2, 2007	Under Task 2 of this phased investigation, the dual rotary drilling method was used to successfully construct a test slant well at the mouth of San Juan Creek.
Subsurface System Intake Feasibility Assessment Task 4 Report, 2007.	A three-dimensional groundwater flow and variable density solute transport model of the proposed subsurface intakes was developed. The model assessed the sustainable yield of a slant well intake system under a variety of configurations to suit a range of raw water capacities and examined the potential impact of intake operations on seawater intrusion and the “fresher” water aquifers.

**Table 2-3 Geotechnical and Biological Assessments Prepared (to date) in Support of Ocean Desalination at Dana Point**

Geotechnical Evaluation South Coast Water District Groundwater Recovery Plant, March 1999.
Phase I Environmental Site Assessment San Juan Creek Properties, May 1999.
Limited Geotechnical Evaluations San Juan Creek Properties, June 1999.
Biological Assessment South Coast Water District Project, South Coast Water District, July 1999.
Geotechnical Evaluation San Juan Creek Property, February 2001.
Updated Geotechnical Recommendations South Coast Water District Groundwater Recovery Facility- Phase I, October 2002.
Updated Geotechnical Evaluation South Coast Water District Groundwater Recovery Plant, December 2003.

## Implications for Proposed Nipomo CSD Desalination Project

The number and type of investigations which were undertaken to provide information for the permitting and design of the proposed desalination facilities noted above provide an indication of the level of effort which may be expected for a similar facility in San Luis Obispo County. Initial discussions with the regulatory agencies listed in Table 2-1 will further define the requirements for these, and possibly other, investigations.

The District should expect to conduct the following types of studies:

- Impacts to terrestrial and freshwater ecosystems;
- Impacts to marine ecosystems;
- Impacts to cultural resources (i.e., archaeological sites);
- Hydrogeologic feasibility and impacts to groundwater resources; and
- Intake, discharge, and treatment feasibility (i.e., Pilot-scale desalination plant)

These studies are discussed below.

## Terrestrial and Freshwater Impact Study

The following section describes a proposed study of terrestrial and freshwater ecosystems which may be impacted by the proposed project.

### Existing Information

In 2006, California State Parks released an “Alternative Access Study” for Oceano Dunes State Vehicular Recreation Area, prepared By Condor Environmental. This report contains information pertinent to the terrestrial and freshwater impacts of the proposed project.

Potential impacts of the a District-owned desalination project to terrestrial and freshwater resources have recently been examined (*Supplemental Water Alternatives Environmental And Permitting Constraints Analysis*, Padre Associates, Inc., prepared for Nipomo Community Services District, May, 2007), and are summarized below.

- The desalination facility project is proposed in the Southern portion of San Luis Obispo County, and will be situated in the Nipomo-Guadalupe Dune complex, “a unique and sensitive area that has been heavily protected by land acquisition, land use planning, and regulatory activities.”
- Numerous threatened or endangered species, such as the Western snowy plover and the California least tern, are present within the dune complex and along the beach areas of the Nipomo-Guadalupe dunes.
- The area around the Conoco-Phillips refinery is known to contain special-status plant species (e.g. Nipomo Mesa Lupine, La Graciosa Thistle, Dune Larkspur), as well as sensitive habitat (Central Coast Dune Scrub).

## Work Plan

1. Complete a California Red-Legged Frog (CRLF) protocol-level surveys during the CRLF breeding season (January 1 through June 30) to identify populations of CRLF within the limits of the project boundary and nearby areas.
2. Botanical surveys should be conducted to determine the likelihood of impacts within any proposed pipeline alignments, at the pilot plant site, at the test intake and discharge sites, and at the treatment plant facilities. Alternative sites and alignments should be investigated so that impacts to rare plants can be avoided or minimized. The potential for seed collection and restoration, as necessary, should also be evaluated.
3. A wetland delineation should be conducted to determine the likelihood of impacts to wetlands or other waters of the U.S. within pipeline alignments and other impacted areas.
4. Propose site protection and impact minimization measures that can be incorporated into the construction and operation of the proposed test intake and discharge facilities, pilot plant, intake and discharge facilities, pipelines, and treatment plant.

## Marine Impact Study

### Existing Information

The proposed project calls for beach wells or intake galleries that would draw seawater from permeable zones within the near shore environment and beach areas.

Similar subsurface structures are also proposed for brine disposal.

The proposed sites for the feasibility study and intake and discharge facilities are exposed beaches.

In the vicinity of the ConocoPhillips outfall the slope of the ocean bottom is approximately 1.6% (27 feet depth at 1700 feet from shore.) (RWQCB, 2002)

## Work Plan

1. Map the benthic topography and marine habitat types. Note the presence of sensitive habitat types that should be avoided such as kelp and hard bottom habitats, or other areas where resident species may be more sensitive to changes in water quality.
2. Select a site that is not planned to be impacted, yet is likely to be similar to the areas where impacts are planned. This site will be used as a reference or “background” site. Investigate this site, as well as the sites where impacts are planned, as discussed below.

3. Monitor the currents, tides, water depths, temperature, and salinity. Collect additional water quality data as appropriate. This data will be used in the development of models used to estimate the impact of the proposed project.
4. Quantify the ambient or “background” conditions, including daily and seasonal variations, and assess the existing level of water quality impairment (if any).
5. Sample the water column and benthic environments to determine species that are present. Determine and calculate appropriate indices of species richness and abundance.
6. Determine the marine organisms present and how they would be affected by salinity changes, including how the effects may vary by life stage.

## Cultural Resource Impact Study

### Existing Information

The “Alternative Access Study” for Oceano Dunes State Vehicular Recreation Area (ibid.) contains background information pertinent to the cultural impacts of the six potential access corridors studied. Archaeological surveys were conducted in January 2006, identifying or confirming 32 prehistoric and historic archaeological sites that would be impacted by the six potential access roads. The archaeological ground surveys were limited to the areas of the park that would be impacted by the six alternative access roads. Three of the six alternatives that were evaluated are at the southern end of the park, in areas where desalination project pipelines are being considered.

### Work Plan

The purpose of the cultural resource study is to identify historic properties (prehistoric and historic archaeological resources, Native American site, and/or architectural properties) listed, determined or potentially eligible for inclusion on the California Register of Historical Resources (California Register) that could be affected by the proposed project, and to recommend measures to avoid, minimize, or mitigate impacts to these resources.

1. Conduct a search of prehistoric and historic site records and pertinent literature concerning the initial project alignments.
2. If needed, conduct a preliminary field survey of the initial project alignments.
3. Prepare a memorandum containing the results of the records search for the proposed project alignments, a brief review of pertinent literature, results of the field survey, summary of key findings, and management recommendations.

# Section 3 Feasibility Studies

## Hydrogeologic Feasibility Study

### Conceptual Intake Options

Although potential intake options include both wells and open intakes, it is recommended that the District plan for construction of beach wells as discussed in the Scope of Work. Open intakes are typically discouraged by regulatory agencies, because they result in impingement of marine organisms and the construction typically has a greater impact on benthic communities than beach wells.

### Conceptual Discharge Options

In this study, Boyle performed a preliminary evaluation of discharge options, including use of the Nipomo Refinery ocean outfall, construction of a new ocean outfall, and installation of subsurface discharge wells or an infiltration gallery. Based on our review of similar projects, and discussions with permitting agencies (including RWQCB), it appears the subsurface discharge presents the most feasible alternative for the District for the following reasons:

- **Nipomo Refinery outfall capacity is inadequate.** The Nipomo Refinery outfall cannot convey a sufficient quantity of brine discharge (approximately 6300 AFY at 50% recovery for an RO system), as concluded by Cannon in the District's draft Water Master Plan. In addition, the condition of the outfall is questionable because it was constructed in the 1950's and has not be replaced.
- **Open discharges or ocean outfalls are discouraged by resource agencies.** Construction of a new ocean outfall may be discouraged by regulatory agencies, who prefer subsurface discharges because they typically promote better mixing of brine and seawater, have less water quality impact than a direct outfall, and the construction is less disruptive to benthic organisms.

Therefore, we recommend planning based on a subsurface discharge, but continuing to consider the open discharge or ocean outfall as a viable alternative if the geology is not appropriate for subsurface discharge.

### Preliminary Intake and Discharge Locations

The following locations are recommended for investigation as to their suitability for placement of a subsurface seawater intake structure:

- Site 1: Pacific Ocean at extension of Black Lake Canyon
- Site 2: Pacific Ocean at extension of Willow Road
- Site 3: Pacific Ocean south of mouth of Oso Flaco Creek

These sites were selected based on an evaluation of the hydrogeologic information summarized below, each site’s distance from a proposed desalination facility, minimization of environmental impacts, and potential cooperation of affected landowners.

**Summary of Existing Information**

The California Department of Water Resources, Southern District, produced a report “Water Resources of the Arroyo Grande – Nipomo Mesa Area” in 2002. Information pertinent to the construction of a subsurface seawater intake and outfall is summarized below.

The locations of the proposed intakes/outfalls are centered around the monitoring well labeled 11N/36W-12C in the following figure. This well exhibited artesian flow when sampled in April, 2007.

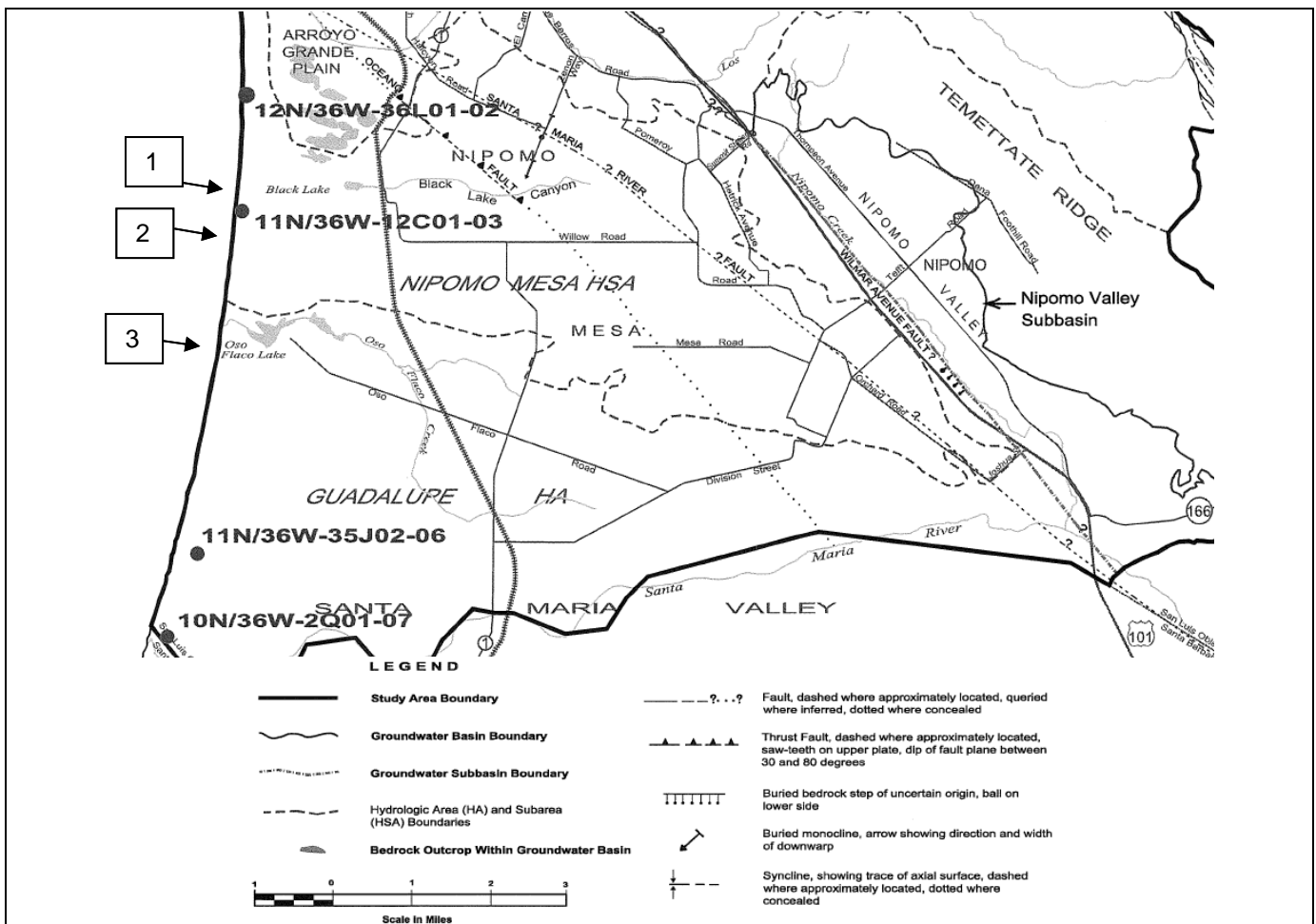

Source: Department of Water Resources, Southern District. “Water Resources of the Arroyo Grande – Nipomo Mesa Area,” 2002, Plate 18.

**Figure 3-1 Seawater Intrusion Monitoring Wells**



The surface geology in this area consists of “Dune Sands”, as shown below.

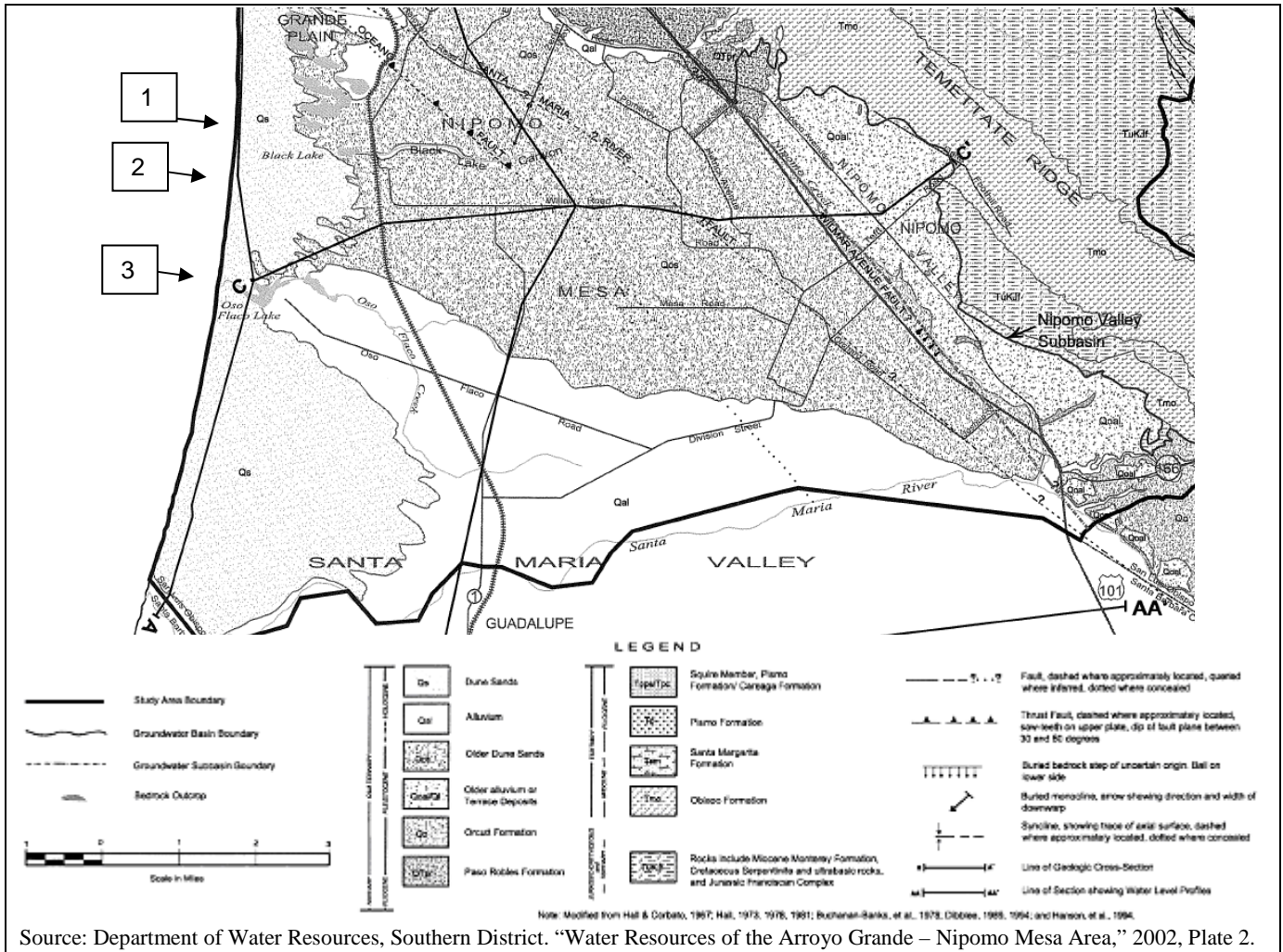

Source: Department of Water Resources, Southern District. “Water Resources of the Arroyo Grande – Nipomo Mesa Area,” 2002, Plate 2.

Figure 3-2 Generalized Geology

Extrapolation of regional well log data show that the dune sand (Qs) deposit, at the southern end of the study area an underlying “alluvial” (Qal) deposit, may extend down to a depth of less than 100 feet at the Pacific coast, as shown in the following two figures. A clay layer appears at the top of the “Paso Robles Formation” (QTpr).

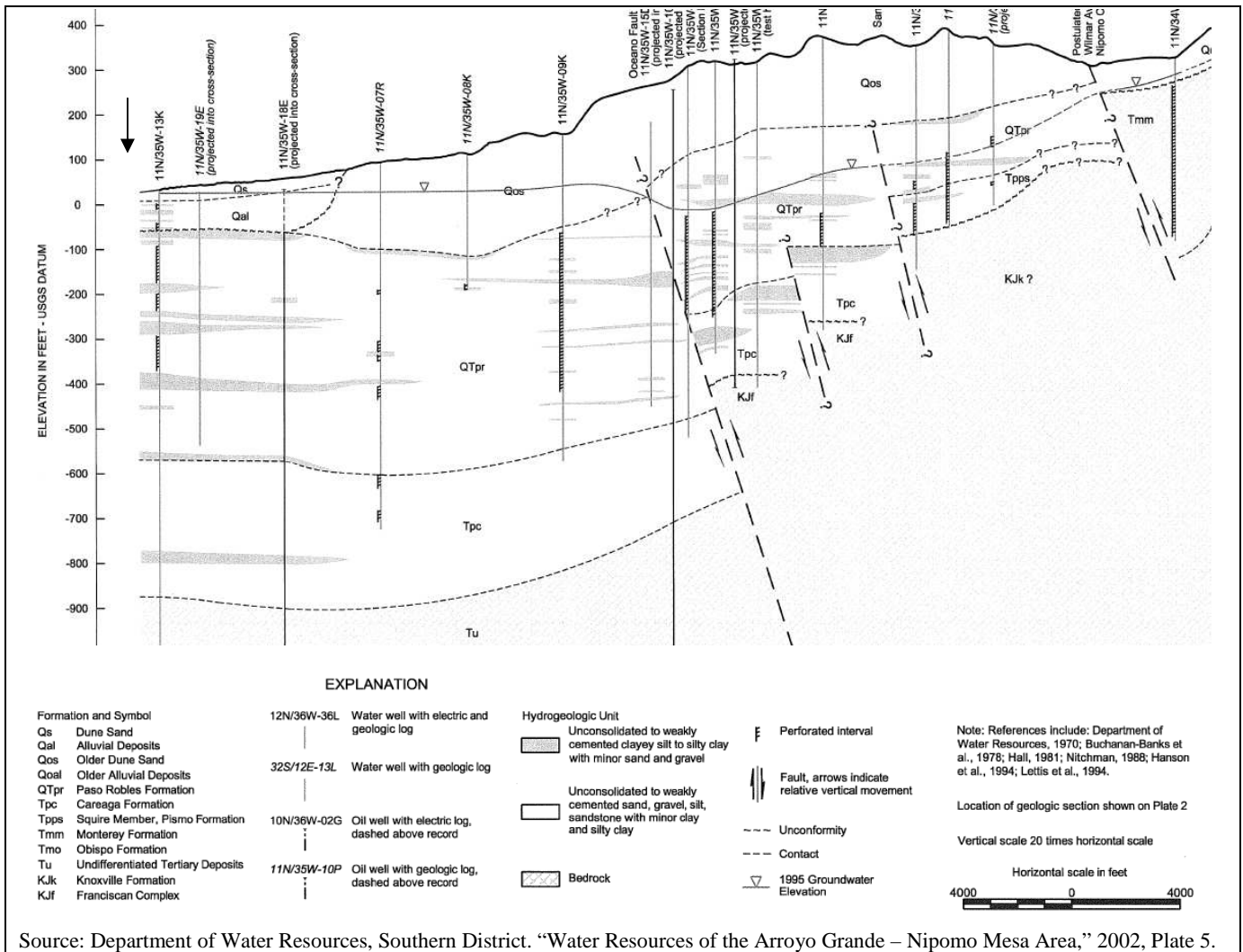

Source: Department of Water Resources, Southern District. “Water Resources of the Arroyo Grande – Nipomo Mesa Area,” 2002, Plate 5.

Figure 3-3 East-West Geologic Section C-C'

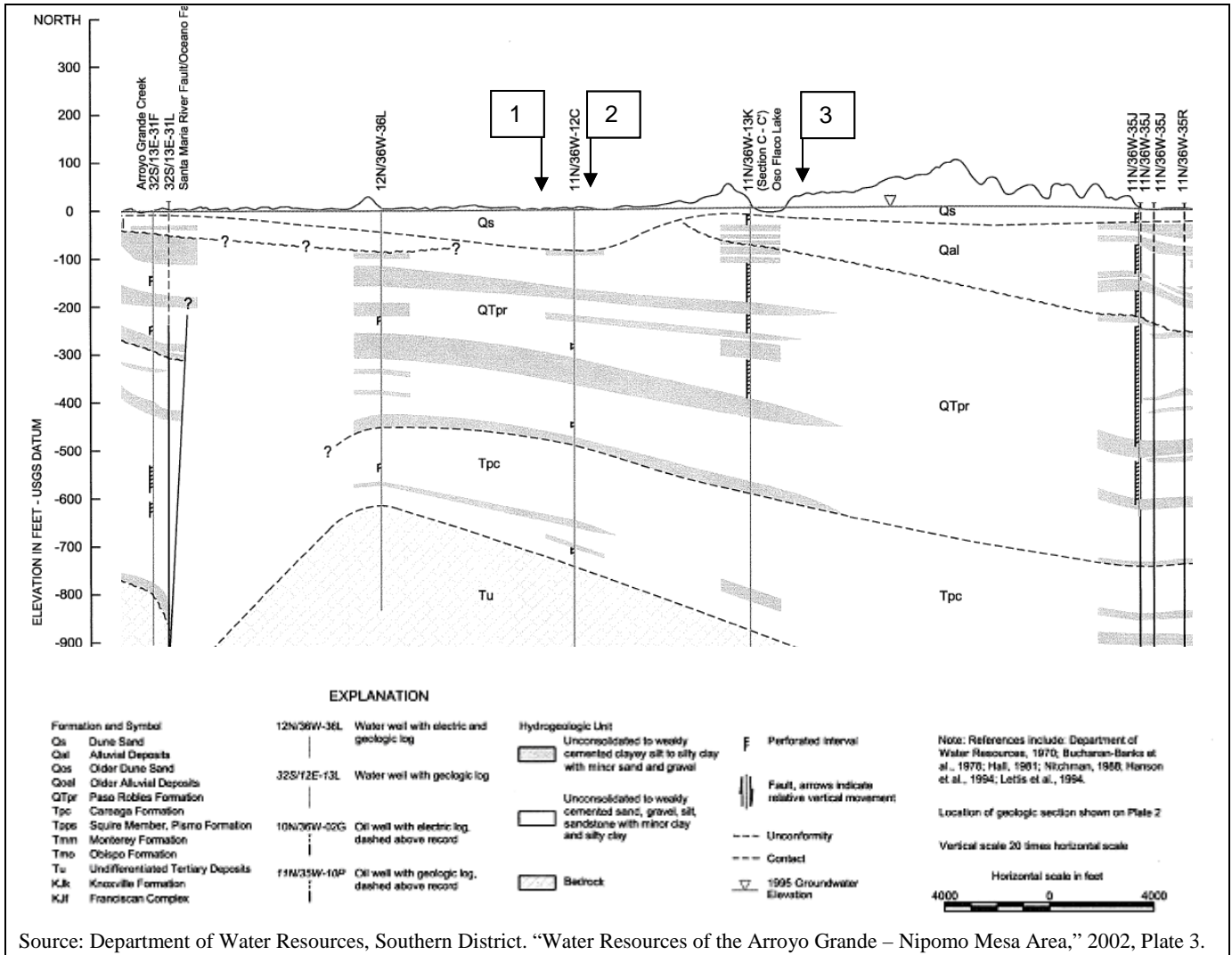

Source: Department of Water Resources, Southern District. "Water Resources of the Arroyo Grande – Nipomo Mesa Area," 2002, Plate 3.

**Figure 4-4 North-South Geologic Section A-A' along Coast**

Water levels in the Paso Robles formation are between 6 and 8 feet above sea level. Freshwater outflows have been estimated to be 1500 AFY in aggregate.

The offshore bathymetry does not show any submarine canyons. In the vicinity of the ConocoPhillips outfall the slope of the ocean bottom is approximately 1.6% (27 feet depth at 1700 feet from shore.) (RWQCB, 2002) Therefore, of the location of the sea water/fresh water interface is unknown at this time.

## Purpose and Goals

The hydrogeologic feasibility study would likely be conducted in two phases.

**Phase 1** - The purpose of the Phase 1 hydrogeologic feasibility study is to determine the geologic characteristics of the proposed sites; and to identify a preferred location for the pilot-scale subsurface intake and discharge facilities.

The Phase 1 goals of this study are:

1. Determine the lithology of the sites.
2. Estimate the permeability of the geologic layers encountered.
3. Describe the hydrogeologic relationships between the site geology and the regional aquifers.
4. Estimate the hydraulic connectivity between the aquifers of interest (beach sands, alluvial deposits, Paso Robles formation) and the ocean.
5. Install monitoring wells that can be used to calibrate the groundwater model and to monitor changes to the aquifers during pilot phase production and during full scale production.
6. Collect sufficient information to select a preferred location and technology for the pilot scale subsurface intake and discharge facilities.

**Phase 2** - The purpose of the Phase 2 hydrogeologic feasibility study is to assess whether the aquifer(s) at the selected location could support a subsurface intake and outfall system.

The Phase 2 goals of this study are:

1. Determine formation and aquifer hydraulic properties;
2. Estimate the potential yield from a subsurface intake system and its configuration; and
3. Assess potential basin water supply benefits and impacts.

## Phase 1 Work Plan

Phase 1 work will occur before installation of the pilot-scale intake and discharge facilities.

1. Review existing hydrogeologic data and estimate the number of test boreholes and monitoring wells which will be needed to assess aquifer materials at the proposed intake and discharge locations.
2. Obtain permits and comply with conditions imposed by regulatory agencies for the proposed field study. These permits/approvals are expected to include:
  - Regional Board
  - USACE
  - California Coastal Commission
  - State Lands Commission
  - State Parks
  - San Luis Obispo County
  - Landowner Approval

3. Drill the test boreholes and install monitoring wells. During the drilling operations, run geophysical logs and collect lithologic samples and water quality samples from the boreholes.
  - In the laboratory, estimate hydraulic conductivities of lithologic samples using a permeameter, sieve the lithologic samples, and estimate the hydraulic conductivities based on grain size analyses.
1. Prepare a report to document the hydrogeologic field study's findings.

### Phase 2 Work Plan

Phase 2 work will occur after installation of the pilot-scale intake and discharge facilities.

1. Conduct one or more pump tests to estimate pertinent hydrogeologic parameters of the aquifer (such as transmissivity, storativity, and leakance).
2. Utilize the results of the pump test and related geological information to develop a three dimensional groundwater flow and variable density solute model of the proposed subsurface intake and discharge facilities.
3. Use the model to estimate impacts to the aquifer(s) and to the ocean environment of long-term operation of the proposed desalination plant.

## Intake Feasibility Study

### Purpose

The purpose of the Intake Feasibility Study is to evaluate the feasibility of installing and operating a subsurface intake.

### Goals

1. Verify technical capability and methods through construction of prototype test facilities;
2. Identify resource management and regulatory permits, as well as other required approvals;
3. Demonstrate the construction of the test facilities in an environmentally sound manner;
4. Estimate intake and discharge capacities; and
5. Determine and verify pretreatment filtration benefits (i.e., determine the quality of raw feed water after it has been filtered through the aquifer materials).

### Work Plan

1. Assess whether the aquifer materials at the proposed locations could support a subsurface intake system for a pilot-scale desalination plant.
2. Based on the hydrogeologic study results, select the most appropriate subsurface intake system technology.
3. Fully describe the test facilities installation and operation plan.
4. Coordinate environmental processing with appropriate regulatory agencies to obtain the required permits and approvals.
5. Finalize the test intake facilities design.
6. Build the test intake facilities.
7. Conduct intake pump testing to estimate aquifer parameters needed to develop the hydrogeologic model noted above.
8. Analyze the data collected and prepare a technical report.

## Discharge Feasibility Study

### Purpose

The purpose of the Discharge Feasibility Study is to evaluate the feasibility of installing and operating a subsurface discharge system.

### Goals

1. Verify technical capability and methods through construction of a prototype test facility;
2. Identify resource management and regulatory permits, as well as other required approvals;
3. Demonstrate the construction of the test facility in an environmentally sound manner;
4. Estimate receiving water quality under a range of flow rates.

### Work Plan

1. Assess whether the aquifer materials at the proposed locations could support a subsurface discharge system for a pilot-scale desalination plant.
2. Based on the hydrogeologic study results, select the most appropriate subsurface discharge system technology.
3. Fully describe the test discharge facility installation and operation plan.
4. Coordinate environmental processing with appropriate regulatory agencies to obtain the required permits and approvals.
5. Finalize the test discharge facility design.
6. Build the test intake facility.
7. Comply with regulatory conditions.
8. Conduct discharge testing and receiving water quality monitoring to estimate aquifer parameters needed to develop the hydrogeologic model noted above.
9. Analyze the data collected and prepare a technical report.

## Treatment Feasibility (Pilot) Study

### Purpose

Determine the feasibility of operating a seawater desalination facility using subsurface intake and discharge facilities by operating a pilot-scale plant.

### Goals

1. Verify technical capability and methods through construction of a pilot-scale plant;
2. Determine and verify pretreatment filtration benefits;
3. Estimate anticipated feedwater water quality under the range of hydrologic conditions expected; and
4. Conduct a long-term pilot study to verify treatment performance.
5. Measure receiving water impacts from the test-scale discharge.

### Work Plan

1. Design a pilot plant.
2. Obtain permits and comply with conditions imposed by regulatory agencies for installation and operation of the proposed pilot plant.
3. Install the test the pilot plant.
4. Operate the intake structure in a manner that allows sufficient information to be collected to (a) determine and verify pretreatment filtration benefits, (b) determine formation and aquifer hydraulic properties, (c) estimate the potential yield from a subsurface intake system, and (d) estimate anticipated feedwater water quality under a range of hydrologic conditions.
5. Operate the pilot plant in a manner that allows sufficient information to be collected to verify treatment performance under the range of conditions that are expected to be encountered.
6. Operate the test-scale outfall in a manner that allows sufficient information to be collected to determine receiving water impacts under the range of conditions that are expected to be encountered.
7. Prepare a test-scale feasibility report to document the study's findings.



# Section 4 Preliminary Engineering

## Purpose

Provide project description sufficient for beginning the CEQA and possibly NEPA processes, as well as selecting major process components for subsequent detailed design.

## Goals

Define conceptual design elements such as raw water and brine discharge pipelines; beach wells and subsurface discharge facilities; treatment plant; treated water pipelines; establishment of project phasing and water delivery schedule; connection(s) to the District water distribution system; disinfection; operational storage and pumping facilities; chemical addition required to reduce corrosion and “match” district water quality; and in-system improvements required to reduce hydraulic bottlenecks or improve water distribution.

## Approach

It is assumed the following study elements would be included in the Preliminary Engineering stage of project development:

- Conceptual beach well and discharge facility layouts (including visual analysis);
- Raw water and brine discharge pipeline preliminary studies (alignment, materials, and size);
- Treatment plant site study (including size, layout, and visual analysis). The sites currently being considered are briefly described in Appendix A (Treatment Plant Site Options);
- Hydraulic analysis (addressing range of product flows, identification of hydraulic bottlenecks, conceptual pump sizing, and distribution system improvements); and
- Water quality evaluation (focus would include recommendations for chemical treatment to reduce corrosion potential of desalted water and disinfection system including investigation of compatibility with other District facilities).
- Pretreatment and treatment process description (including raw water quality, finished water quality, chemical additives, concentrate water quality, and residuals management);
- System integration/connection to distribution system (including layout, facilities, and operation);
- Power requirements and electrical supply study;
- Facilities plan and opinion of probable costs
- Schedule and procurement strategy

# Section 5 CEQA/NEPA Process

## Purpose

The purpose of the CEQA/NEPA Process component of the proposed project is to satisfy the requirements of the California Environmental Quality Act and the National Environmental Policy Act so that the proposed desalination project can be implemented.

## Goals

The goals of the CEQA/NEPA Process component of the proposed project are to provide accurate resource assessment and impact information to stakeholders, provide adequate notice and opportunities for comment by stakeholders, and eliminate or mitigate significant impacts of the project.

## CEQA Compliance Approach

Compliance with CEQA will be required. Given the scope of the proposed desalination project, it is assumed that a full Environmental Impact Report (EIR) will be required. The recommended work plan for preparing this EIR is:

- Publish and otherwise distribute a Notice of Preparation (NOP) to notify interested parties that the District will be preparing an EIR to evaluate potential environmental impacts of the proposed project.
- Widely distribute a Notice of Availability (NOA) to potentially interested members of the public about the availability of the NOP and the scheduled public scoping meetings.
- Hold a series of scoping meetings during the 30-day (minimum) project scoping period. Hold meetings in Nipomo, Santa Maria, and the 5-cities portion of San Luis Obispo County.
- Prepare a draft EIR, addressing pertinent issues raised during the scoping process.
- Publicly notice the availability of the draft EIR for review.
- Hold meetings to receive comments on the EIR.
- Modify proposed project and the EIR as needed.
- Adopt the EIR as modified.

## NEPA Compliance Approach

Compliance with NEPA will be required because several federal agencies (USACE, NMFS, USFWS, etc.) will need to permit the project.

*“The National Environmental Policy Act (NEPA) requires federal agencies to integrate environmental values into their decision making processes by considering the environmental impacts of their proposed actions and reasonable alternatives to those actions. To meet this requirement, federal agencies prepare a detailed statement known as an Environmental Impact Statement (EIS). EPA reviews and comments on EISs*

*prepared by other federal agencies, maintains a national filing system for all EISs, and assures that its own actions comply with NEPA.”*

- <http://www.epa.gov/compliance/nepa/index.html>

To assist these agencies in completing their EIS's, the following actions should be undertaken:

1. Consult each agency affected and determine which agencies will be preparing an EIS, or which agency will take the lead in preparing an EIS for use by federal agencies.
2. Communicate with the EIS-preparing agency to determine what types of information will be needed to complete the EIS.
3. Coordinate with other team members to insure that the information is furnished as needed.

# Section 6 Public Outreach

## Purpose

The purpose of the Public Outreach component of the proposed project is to provide a consistent, centralized, and continuous public information resource for the implementation of public outreach activities that will be needed to gain public and agency approval to build and operate the proposed desalination project.

## Goals

The goals of the Public Outreach portion of the proposed project are:

1. Provide a centralized location for information regarding the proposed project. This information will include status reports, technical reports, environmental assessment reports, public outreach material, schedules, etc.
2. Provide a framework for delivering a consistent description of the proposed project to stakeholders, pertinent regulatory agencies, and the general public.

## Work Plan

1. Designate a Public Outreach Coordinator, either a member of NCSD staff or a consultant. The Public Outreach Coordinator will be responsible for coordinating public outreach efforts with other aspects of the project, including:
  - reviewing submittals to regulatory agencies for consistency with other documents;
  - providing periodic updates to NCSD and the public;
  - responding to NCSD concerns and direction; and
  - responding to requests for information.
2. Initiate a public outreach campaign to inform stakeholders and the general public about the proposed project.
3. Establish a web site devoted to the project. Post public documents associated with the project.

# Section 7 Design and Permitting

## Coordination of Design and Permitting Activities

Preceding activities will define the basic project (including intake, discharge, and treatment facility concepts), so that design and permitting can proceed concurrently. It is assumed one of the major design goals will be to minimize permit issues and proactively address resource agency concerns expressed during initial project planning activities.

## Design and Permitting Issues

The following issues should be addressed during design and permitting:

**Minimizing Energy Consumption**— Reverse Osmosis (RO) desalting is energy intensive. There are several potential opportunities for minimizing energy consumption of the desalting project. These include careful attention to details such as minimizing hydraulic losses through piping and valving, selection of efficient pumps, etc. In addition, four opportunities could reduce energy consumption significantly. These include:

- The RO feedwater pressure in a seawater desalting plant is typically on the order of 1000 psi. Permeate, perhaps 50% of the feedwater, exits the RO equipment at low pressure (perhaps 20 psi). The remaining 50% of the RO feedwater exits the RO equipment as concentrate at a pressure very near the RO feedwater pressure. That is, about 50% of the pumping energy in the RO feedwater remains in the concentrate exiting the RO equipment.
- Reducing RO membrane flux (or flow rate per unit area of filter) below typical values. Seawater RO plants typically operate at fluxes of 8 or 9 gallons per square foot (of membrane area) per day (gfd). Reducing flux can significantly reduce costs. For example, Boyle recently provided “value engineering” services to the Honolulu Water Supply Board regarding the design of the Kalaeloa 5 MGD seawater desalting plant. The designers initial used a design flux value of 9.5 gfd. Boyle calculated that reducing the average flux to 6.1 gfd would add \$1,500,000 in construction costs but save \$500,000 per year in O&M costs. The \$1,500,000 in construction cost includes additional RO membranes and pressure vessels. The O&M cost savings accounts for more membrane elements being required, but that cost is more than offset by power cost savings (at \$0.10/KWhr.)
- Alternatives to purchasing all of the power needed for the desalting project from PG&E should be considered. Utilization of “waste heat” from the Nipomo Refinery cooling system may be an option.
- Feed pump selection is critical to designing an energy-efficient RO facility. For instance, positive displacement (piston) type pumps should be considered instead of centrifugal pumps. They offer several distinct advantages including:
  - a) Piston pumps operate at a constant speed and flowrate, but variable pressure whereas vertical turbine pumps need to be equipped with variable frequency drives (VFD) so the pump speed can be adjusted to provide the flow and pressure required;
  - b) Piston pumps operate in the range of 300 RPM whereas centrifugal pumps for seawater RO plants operate at about 3000 RPM;

- c) The life-cycle cost of piston pumps is typically less than for centrifugal pumps; and,
- d) Piston pumps are typically at least 15% more efficient than centrifugal pumps.

**Noise Attenuation**—The proposed desalting plant may be located adjacent to another industrial facility, and is nearby to state park and recreational areas. The desalter can be expected to generate noise, and it is unknown whether this will be a significant concern. “Point noise sources”, such as pumps, can be “boxed” in sound reducing enclosures. In addition, the building can be insulated to mitigate noises generated inside the building.

**Pretreatment Using Membrane Filtration** - Filtration of seawater, prior to RO, should be considered. The budget estimates presented in this TM assume prefiltration will be provided. Even if pilot testing suggests that seawater from the proposed subterranean intake exhibits a low Silt Density Index (SDI), filtration should be considered as “insurance” to prevent solids from reaching the RO membranes and damaging or destroying them. Considering the cost of the project and its importance to the District, installing filtration as pretreatment for the RO feedwater is recommended. Furthermore, membrane filtration is recommended in lieu of conventional filtration because experience has shown that membrane filtration provides much better quality water on a consistent basis. This higher quality water is reflected in easier and less expensive operation and maintenance including less frequent membrane replacement.

**Xenobiotics** - Xenobiotic is a term that has been coined to collectively aggregate pharmaceuticals and drug metabolites, personal care products, hormones, plasticizers, pesticides (including many that have been banned for decades), petrochemical byproducts and metabolites, and other potential endocrine disrupting chemicals. This is an emerging field of interest to water quality professionals. Of particular interest in a seawater-desalting project is domoic acid, an organic acid produced by diatoms. (Diatoms are a common type of phytoplankton.) This acid is extremely toxic to some marine species. Its impact on humans is not yet known. Neither is the amount (concentration) present in seawater at any particular location known.

Treating for removal/destruction of xenobiotics is in its infancy. (A xenobiotic is a chemical which is found in an organism but which is not normally produced or expected to be present in it. Specifically, drugs such as antibiotics are xenobiotics in humans because the human body does not produce them itself nor would they be expected to be present as part of a normal diet. However, the term is also used in the context of pollutants such as dioxins and polychlorinated biphenyls and their effect on the biota.) RO membranes remove some xenobiotics. Other potential treatment processes include carbon adsorption, ultraviolet light, and electron beam irradiation.

**Boron Reduction** - There is presently no Maximum Contaminant Level (MCL) for boron in drinking water. Boron concentration in seawater is in the range of 4 mg/L, and boron limits are commonly included in waste discharge requirements (WDRs) for wastewater treatment facilities around the state. Seawater RO membranes would reject some of the boron, but not all. If additional boron removal should be needed, ion exchange could be employed.

### California Department of Health (DHS) Issues

- ❑ Sanitary Survey and Source Water Assessment—The DHS will most likely require a Sanitary Survey and Source Water Assessment for the project. Defining the area to be covered by the Sanitary Survey will probably require negotiation with DHS.
- ❑ Disinfection Requirements—Even if the seawater supply to the desalter should come from an subsurface collection system, it would still be considered surface water. It would be necessary to meet the Surface Water Treatment Rule. Membrane filtration and RO will certainly meet the filtration requirements. However, it should be expected that the DHS would also require at least 0.5 Log inactivation of giardia and 1.0 Log inactivation of viruses. Disinfection using chlorine or chloramines, with provisions to provide contact time prior to delivery of the desalted water to the first customer, should be anticipated.
- ❑ Disinfection By-Products—Chlorination byproducts such as Trihalomethanes (THM) and haloacetic acids (HAA) are not expected to be a problem. However, should ozone be used, bromate would be a problem. There is also the potential for xenobiotic disinfection byproducts. As noted above, xenobiotics is a new field and means of removing/destroying them are yet to be demonstrated.

### General Approach

Project Design will likely consist of a Concept Design Report (including 30% plans and estimate) and 60%, 90%, and 100% plans, specifications, and estimates. Permitting will likely proceed in parallel with project design as follows:

- The Concept Design Report will become the basis of permit applications;
- Draft permit conditions will be included in the 60% submittal; and
- Final permit conditions will be incorporated in the 90% submittal.

Permit issuance should occur prior to completion of final plans and specifications, and prior to bidding the project and procuring a contractor.

Other work items that are typically performed during this phase may include:

- Prequalification and equipment selection for reverse osmosis system and/or pretreatment equipment (if necessary)
- Prequalification of (sub)contractors for beach well construction;
- Prequalification of general contractors for RO treatment plant construction;
- Value engineering of the 30% design; and
- Selection of a construction manager, and possibly use of their services for constructability review at the 60% and 90% progress milestones.

# Section 8 Bidding and Construction

## Overview

After design activities are completed, and permits are in hand, procurement of one or more contractors can proceed. Prequalification of consultants and/or subconsultants for specialty construction items was discussed briefly in the preceding section.

## Bid-Phase Activities

Developing a bid strategy is critical for projects such as desalination facilities, with specialty items such as beach wells and treatment process equipment. This project will likely attract attention from contractors around the nation. The bid phase for this project could consist of several bid phases for separate work items, which overlap or are accomplished in parallel, or one bid phase for one contract (if multiple contracts are not issued). For the purposes of this project schedule, it is assumed the bid phase will be approximately 60-90 calendar days and will include the following activities:

- Prebid meetings (either mandatory or non-mandatory);
- Bid advertisement;
- Bid review and recommendation for award(s);
- Contract negotiation; and
- Notice to proceed

## Construction-Phase Activities

Construction-phase activities will include construction by one or more contractors;

- Environmental mitigation and monitoring of various project components (as established in permit conditions and in CEQA/NEPA processes);
- Construction management and operation;
- Startup and testing of project components;
- Performance testing of the completed facility (as required by CDHS); and
- Initial deliveries to potable water customers.



# Section 9 Schedule

A detailed schedule is included in Appendix C, and is summarized below. Note that the schedule presented is a “best case” opinion and assumes that no significant obstacles to implementation arise in the course of the impact studies, feasibility studies, design, environmental review, and construction.

Note that this is a “best case” projection, and that management and public outreach tasks are not shown as these tasks are assumed to run for the length of the project.

## Projected Schedule

<b>Task</b>	<b>Projected Completion Date</b>
Terrestrial and Freshwater Impact Studies	April 2008
Phase 1 Marine Impact Studies	January 2009
Cultural Resource Study	March 2008
Phase 1 Hydrogeologic Field Study	July 2010
Test-Scale Feasibility Study	March 2013
Phase 2 Hydrogeologic Field Study	April 2013
Preliminary Engineering	October 2013
CEQA/NEPA	March 2014
Design and Permitting	March 2015
Bidding and Construction	May 2016

# Section 10 Budget

## Probable Cost of Implementation and Operation

An opinion of the probable cost of implementing and operating the proposed project, producing 6,300 acre-feet (af) per year, is presented below. Implementation costs are annualized at 6% over 20 years to determine probable annual costs.

	Cost	Annual Cost**	Cost/af
<b>Implementation Costs*</b>			
Terrestrial and Freshwater Impact Studies	\$ 440,000		
Phase 1 Marine Impact Studies	250,000		
Cultural Resource Study	66,000		
Phase 1 Hydrogeologic Field Study	360,000		
Test-Scale Feasibility Study	2,320,000		
Phase 2 Hydrogeologic Field Study	180,000		
Preliminary Engineering	210,000		
CEQA/NEPA	240,000		
Public Outreach	1,310,000		
Design and Permitting	3,870,000		
Construction	67,940,000		
Project Management	1,500,000		
<b>Total before Escalation</b>	<b>\$ 78,700,000</b>		
Cost Escalation	19,510,000		
<b>Total with Escalation</b>	<b>\$ 98,210,000</b>	<b>\$8,562,000</b>	<b>\$1,400</b>
<b>Operation and Maintenance Costs</b>			
Intake Pipeline Pumping Cost @ \$0.13/kWh		\$180,000	\$29
Treatment Plant Operation and Maintenance		\$6,220,000	987
Delivery Pipeline Pumping Cost @ \$0.13/kWh		\$630,000	\$100
<b>Subtotal O&amp;M Costs</b>		<b>\$7,030,000</b>	<b>\$1,100</b>
<b>Total</b>		<b>\$15,590,000</b>	<b>\$2,500</b>
* Cost items include allowance for 20% to 30% contingencies.			
** Implementation costs annualized at 6% over 20 years.			

### Phased Implementation

It may be possible to implement the proposed project in phases. Phase 1 would produce 3,000 acre-feet per year (afy) and Phase 2 would produce an additional 3,300 afy. All of the intake, discharge, and delivery facilities would be implemented during Phase 1. Most of the treatment plant itself would also be constructed during Phase 1, with provisions made for future connection of additional pre-treatment and RO components. An opinion of probable construction costs associated with this phased approach is presented in Appendix D. It is expected that under a phased approach at most 20% of implementation costs could be shifted to Phase 2. Probable total and annualized costs for Phase 1 would be as follows:

	Cost	Annual Cost	Cost/af
<b>Phase 1 Implementation Costs</b>			
Terrestrial and Freshwater Impact Studies	\$ 440,000		
Phase 1 Marine Impact Studies	250,000		
Cultural Resource Study	66,000		
Phase 1 Hydrogeologic Field Study	360,000		
Test-Scale Feasibility Study	2,320,000		
Phase 2 Hydrogeologic Field Study	180,000		
Preliminary Engineering	210,000		
CEQA/NEPA	240,000		
Public Outreach	1,310,000		
Design and Permitting	3,870,000		
Construction	58,200,000		
Project Management	1,500,000		
<b>Total before Escalation</b>	<b>\$ 68,950,000</b>		
Cost Escalation	16,940,000		
<b>Total with Escalation</b>	<b>\$ 85,890,000</b>	<b>\$7,488,000</b>	<b>\$2,500</b>
<b>Operation and Maintenance Costs</b>			
Intake Pipeline Pumping Cost @ \$0.13/kWh		\$86,035	\$29
Treatment Plant Operation and Maintenance		\$2,960,000	\$987
Delivery Pipeline Pumping Cost @ \$0.13/kWh		\$300,000	\$100
<b>Subtotal O&amp;M Costs</b>		<b>\$3,346,035</b>	<b>\$1,100</b>
<b>Total</b>		<b>\$10,830,000</b>	<b>\$3,600</b>
* Cost items include allowance for 20% to 30% contingencies.			
** Implementation costs annualized at 6% over 20 years.			

# Section 11 Conclusions and Recommendations

The District Board should consider the following

- As presented in this Work Plan, implementation of a desalination plant may require approximately \$79 M on a present worth basis (not including contingency or cost escalation, which are included in the cost opinions and cashflow analyses presented in this study). These estimates are considered preliminary, and may change significantly as the project proceeds.
- Additional costs include the distribution system improvements for the long-term Supplemental Water Project as recommended in the draft Water Master Plan.
- The implementation period may take over 8 years.
- While other seawater desalination projects similar in size to the District's project, or larger (such as the Monterey Bay, or Dana Point facilities) have put significant time, effort, and expense into permitting and initial studies for a desalination project, neither projects have received all their permits and they are still in the pilot testing and feasibility study phases.
- Little is known about the hydrogeologic characteristics of the areas proposed for subsurface intakes and discharges. Therefore, it is unknown whether these structures will be feasible.
- Although the South SLO County desalination study participants have not begun implementation of a desalination project, there may be considerable pressure from regulatory agencies to form a regional partnership in lieu of developing two (2) desalination projects approximately 6-7 miles apart.

Boyle recommends proceeding with the following tasks, in order to begin implementation of a desalination project:

- Begin initial funding analysis of this project, in order to assess developer impact fees, water rates, and financial responsibility of project partners (other Nipomo Mesa water purveyors);
- Conduct an initial meeting with the San Luis Obispo County planning department, and other resource agency representatives, in order to begin identifying permitting issues and processes;
- Contact PG&E and discuss availability of power at the potential treatment plant sites, in order to identify the schedule and cost to upgrade electrical service to these locations (if required);
- Meet with the South SLO County desalination study partners to discuss potential for working together; and
- Begin searching for appropriate grant funding sources.

# Section 12 References

Boyle Engineering, Engineering Feasibility Study, Dana Point Ocean Desalination Project, March 2007, prepared for Municipal Water District of Orange County.

California Department of Water Resources, Southern District, "Water Resources of the Arroyo Grande – Nipomo Mesa Area," 2002,

California Regional Water Quality Control Board Central Coast Region, Staff Report for Regular Meeting of April 19, 2002, Prepared March 20, 2002, Item: 11, Subject: Reissuance Of National Pollutant Discharge Elimination System Permit For Tosco Refining Company, Santa Maria Refinery, San Luis Obispo County--Order No. R3-2002-0010, NPDES No. CA0000051.

Condor Environmental, Alternative Access Study, Oceano Dunes State Vehicular Recreation Area, Prepared For California State Parks, Oceano Dunes District, November 15, 2006.

Monterey Bay National Marine Sanctuary, 2003, Draft Action Plan: Coastal Development: Desalination, revised: May 13, 2003

# Appendices

## Appendix A: Treatment Plant Site Options

## Treatment Plant Site Options

As directed by the Board, Boyle evaluated three (3) potential sites for the proposed desalination facility. The following criteria were important in evaluating these sites:

1. Ability of the District to purchase the property;
2. Proximity to existing District service area;
3. Proximity to the proposed beach well/subsurface discharge sites;
4. Availability of power sufficient for a desalination facility;
5. Appropriate zoning for an industrial facility, and “buffer” from residential or commercial areas; and
6. Limited visual impact.

Boyle reviewed three (3) potential sites (see Figure A-1) with District staff. General opinions about these sites are summarized below:

**Site 1 – South County SLO County Sanitation District Facility (Partnership with Arroyo Grande, Grover Beach, and Oceano CSD):** Utilization of this site would require regional partnership and cooperation. At this time, the other agencies have not developed a formal Memorandum of Understanding or an agreement to begin implementing a desalination project, although they have received a Proposition 50 grant to perform a desalination feasibility study. The site is approximately seven (8) miles from the District service area, which is 5-6 miles farther than the other proposed sites. Because the site is located within the SSLOCSW Wastewater Treatment Facility’s (WWTF) property, it would be in an appropriate area from the land planning perspective. In addition, the South SLO County agencies are planning to utilize the SSLOCSW WWTF’s ocean outfall for brine discharge. If Nipomo joined this partnership, a different discharge strategy must be pursued because the other agencies had planned to utilize all the capacity in the outfall for their project (approximately 2300 AFY of production).

Boyle reviewed these issues with District Staff, and it was decided this site would be considered in the future but had some potential fatal flaws.

**Site 2 – Adjacent to Nipomo Refinery:** This site is not currently owned by the District, but the owners of the Refinery may consider selling, or leasing, it to the District. The site is approximately 1.5 miles from major transmission lines within the District’s service area, which is preferable compared to Site A, but the distance to the ocean is approximately 3 miles. The Refinery is zoned as an industrial facility, so a desalination plant would be considered an appropriate land use for the adjacent property because visual impacts (and possibly noise) would not be significant concerns. In addition, the Refinery may be able to provide “waste heat” from their cooling operations in order to help reduce the District’s power costs. The cost opinions developed in this TM were based on locating the plant at this location.



**Site 3 – Undeveloped Parcel on Highway 1:** This 35 acre parcel is not currently owned by the District, but the owners may consider selling it to the District. The site is approximately 2 miles from major transmission lines within the District’s service area, which is preferable compared to Site A. However, the proposed intake and discharge lines would be approximately 5 miles long. The parcel is zoned for rural residential development, so a desalination plant could be considered an inappropriate land use for because visual impacts (and possibly noise) would be significant concerns. However, the western portion of the site is adjacent to Highway 1 and is immediately south of a wastewater treatment site. Therefore, industrial development of the western portion of the parcel may be possible.

DWG: W:\Nipomo CSD (19996)\19996.32 (Alternative Water Supply)\CAD\Exhibits\FIGURE 1-1 - Plant Siting and Pipeline Alignment Alternatives.dwg  
 DATE: Sep 28, 2007 3:40pm XREFS: 0-EDBn11h BEClogo North Arrow IMAGES: Google Earth 9-24-07.jpg New Picture (1).Jump USER: rpi3a

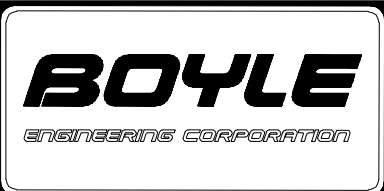
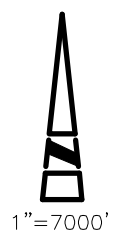
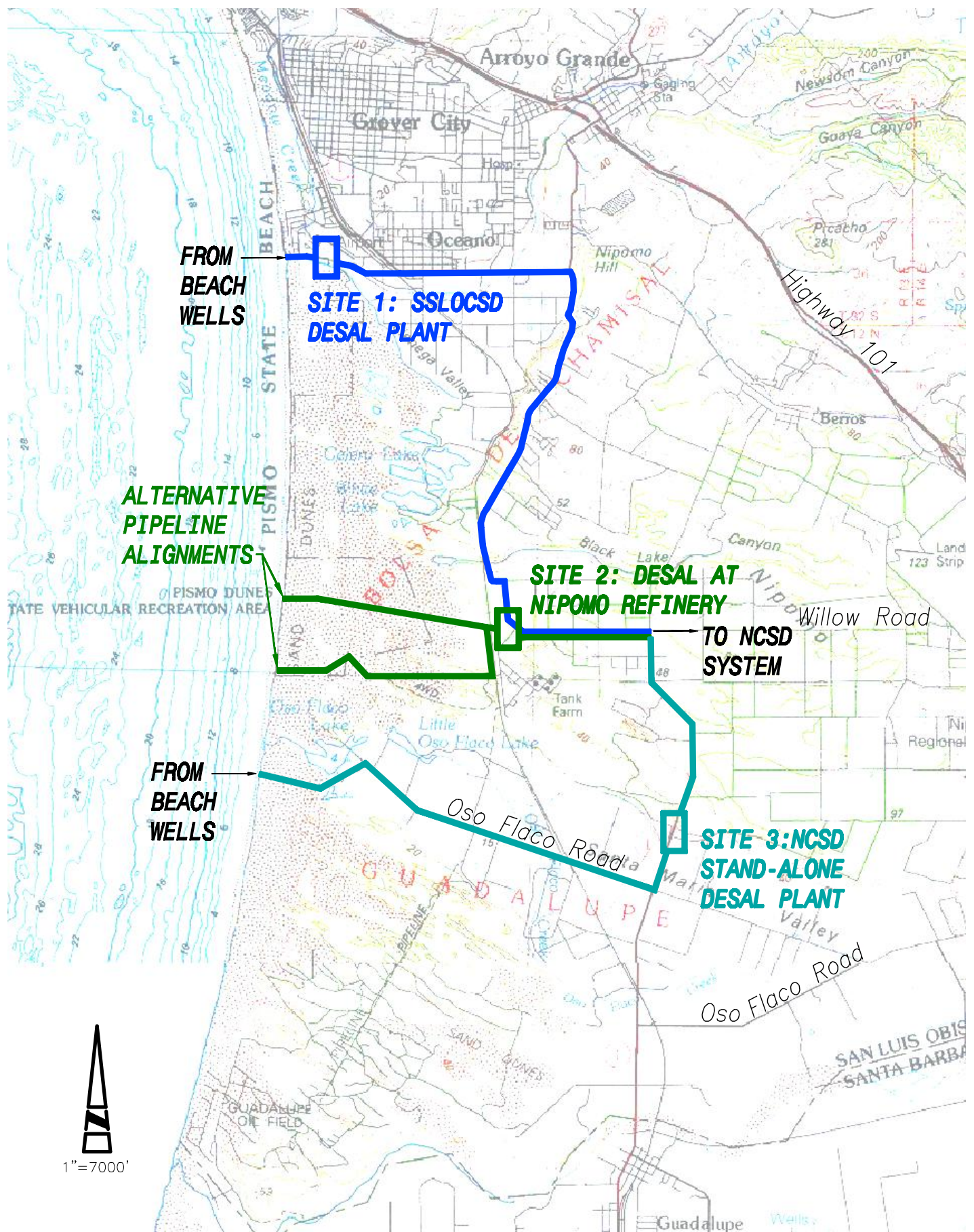

NIPOMO COMMUNITY SERVICES DISTRICT

PLANT SITING AND PIPELINE ALIGNMENT ALTERNATIVES

Copy of document found at [www.NoNewWipTax.com](http://www.NoNewWipTax.com)

BEC PROJECT NO.  
19996.32

FIGURE  
A-1

## **Appendix B: Environmental and Permitting Constraints Analysis**

Supplemental Water Alternatives, Environmental and Permitting Constraints Analysis, Prepared By Padre Associates, Inc. for Nipomo Community Services District, May 25, 2007.

---

**NIPOMO COMMUNITY SERVICES DISTRICT**

**SUPPLEMENTAL WATER ALTERNATIVES  
ENVIRONMENTAL AND PERMITTING CONSTRAINTS  
ANALYSIS**

**Prepared By:**

Padre Associates, Inc.  
811 El Capitan Way, Suite 130  
San Luis Obispo, Ca 93401  
(805) 786-2650

**Prepared For:**

Nipomo Community Services District  
Boyle Engineering Corporation

May 25, 2007



## TABLE OF CONTENTS

		<u>Page</u>
<b>1.0</b>	<b>INTRODUCTION</b> .....	<b>1</b>
	1.1 SCOPE OF SERVICES .....	1
	1.2 DESCRIPTION OF ALTERNATIVES.....	1
<b>2.0</b>	<b>PERMITTING REQUIREMENTS</b> .....	<b>4</b>
	2.1 FEDERAL AGENCIES.....	4
	2.2 STATE AGENCIES.....	5
	2.3 LOCAL AGENCIES .....	7
	2.4 CALIFORNIA ENVIRONMENTAL QUALITY ACT.....	7
<b>3.0</b>	<b>ENVIRONMENTAL CONSTRAINTS</b> .....	<b>9</b>
	3.1 BIOLOGICAL RESOURCES .....	9
	3.1.1 FEDERALLY-LISTED ANIMAL SPECIES.....	9
	3.1.2 SPECIAL-STATUS PLANTS.....	10
	3.1.3 OTHER POTENTIALLY OCCURRING SPECIAL-STATUS SPECIES .....	11
	3.2 WETLANDS/WATERS OF THE U.S.....	13
	3.3 CULTURAL RESOURCES .....	14
	3.4 GEOLOGY AND SOILS.....	15
	3.5 HYDROLOGY AND WATER QUALITY .....	15
<b>4.0</b>	<b>SUMMARY AND RECOMMENDATIONS</b> .....	<b>16</b>
	4.1 SUMMARY OF ENVIRONMENTAL/PERMITTING ISSUES BY ALTERNATIVE .....	16
	4.2 GENERAL RECOMMENDATIONS.....	19
<b>5.0</b>	<b>REFERENCES</b> .....	<b>23</b>

### LIST OF TABLES

Table 1.	Permit Requirements Summary.....	8
Table 2.	Matrix of Required Permits by Alternative.....	21

### LIST OF FIGURES

Figure 1 – Project Alternatives Location Map

Figure 2 – Recorded Occurrences of Special-Status Species – Conoco Phillips Refinery Site

Figure 3 – Recorded Occurrences of Special-Status Species – Oso Flaco Lake Area

Figure 4 - Recorded Occurrences of Special-Status Species – Hutton Road Area

Figure 5 - Recorded Occurrences of Special-Status Species – Wastewater Disposal Alternative

## 1.0 INTRODUCTION

At the request of Boyle Engineering Corporation (Boyle), Padre Associates, Inc. (Padre) has prepared this environmental and permitting constraints analysis for supplemental water supply alternatives under consideration by the Nipomo Community Services District (NCSD). The following provides an overview of the primary environmental constraints and permitting issues associated with the six supplemental water supply alternatives under consideration by the NCSD.

### 1.1 SCOPE OF SERVICES

Padre's scope of services included the following tasks:

- Collection and analysis of existing environmental data for the water supply options;
- Preparation of a constraints analysis identifying potential environmental impacts associated with each of the water supply options;
- Identification of permitting requirements for each alternatives;
- Preparation of a permitting requirements matrix which presents a list of resource surveys and other pertinent environmental information that would be required by permitting and regulatory agencies.
- Preparation of this report presenting Padre's findings regarding the environmental and permitting constraints for the supplemental water alternatives under consideration.

This report is divided into five sections: Section 1 introduces the supplemental water supply alternatives. Section 2 provides a discussion of the federal, state, and local agencies that would be involved in permitting any of the alternatives and types of anticipated permits needed. Section 3 presents an overview of environmental resources that may be affected by the alternative projects and potential constraints to constructing the alternative projects. Section 4 provides a summary of salient points and Padre's recommendations. Section 5 presents the references cited in the report.

### 1.2 DESCRIPTION OF ALTERNATIVES

Presented below are descriptions of each of the water supply alternatives discussed in this report. Refer to Figure 1 for the relative locations of the proposed features of each alternative.

#### **Alternative No. 1 (Sea Water/Cooling Water):**

This alternative would include a water treatment facility located at either the ConocoPhillips (COP) Santa Maria Refinery using process cooling water as a water source, desalination of sea water at another location owned and operated by NCSD, or at the South San Luis Obispo County Sanitation District (SSLOCS) Wastewater Treatment Facility located in Oceano.

**Alternative No. 2 (Oso Flaco Lake Wells):** This alternative would involve treating shallow groundwater or agricultural runoff at Oso Flaco Lake and delivering the treated water to the NCSD distribution system. This alternative may include extraction of either shallow ground

water, or surface runoff from agricultural lands into Oso Flaco Lake could be used as a water supply. The NCSD would build a new ocean outfall for the brine. In addition, enough water would be treated so that “cleaner” water would be released into the watershed to improve the health of the Oso Flaco wetlands.

**Alternative No. 3 (Water Trading with CCWA Agencies):** The State Water Project is a complex system of dams, reservoirs, power and pumping plants, canals, and aqueducts built to convey water from Lake Oroville to the Sacramento Delta, then on to Central and Southern California. The Coastal Branch of the State Water Project consists of (1) water conveyance facilities built by the California Department of Water Resources and (2) regional distribution and treatment facilities constructed by a cooperative group of local water agencies and cities operating as the Central Coast Water Authority (CCWA). Coastal Branch Phase II of the State Water Project was built between 1993 and 1997 to bring State water to San Luis Obispo and Santa Barbara Counties as per the Water Supply Contracts entered into by the State and both counties.

This alternative would consider acquiring unused capacity in the State Water Project (SWP) from one or more CCWA project participants, including acquiring exchange water from one or more CCWA project participants including Golden State Water Company. Water could be provided via a turnout along the State Water Pipeline within the NCSD boundary. This water would then either be delivered directly to the NCSD water system via pipeline from the Tefft Street turn-out, at a Bonita Well turnout, or indirectly via aquifer storage and recovery. As an option, NCSD could buy water directly from the CCWA or utilize aquifer storage and recovery for use of CCWA water for seasonal water needs.

**Alternative No. 4 (Santa Maria Valley Groundwater):** The City of Santa Maria may be willing to sell some of their entitlement to underflow water to NCSD. Facilities required to utilize this resource would include a wellfield, possibly treatment (based on regulatory review), pumping, storage, and a connection from the proposed wellfield to the District distribution system. It is assumed collector wells would be located along the Santa Maria River, near the end of Hutton Road or at the Bonita Well site.

**Alternative No. 5 (Groundwater Recharge from Southland Wastewater Treatment Facility):** This alternative would develop a groundwater recharge program within the Nipomo Mesa Management Area (NMMA) involving recharge of the groundwater basin with recycled water from Southland Wastewater Treatment Facility (WWTF). The NCSD owns and operates the Southland Wastewater Treatment Facility (WWTF), located just west of Highway 101 in the southern portion of Nipomo. It is anticipated recycled water could be pumped to the proposed recharge facilities during certain periods of the year. It is understood that the NCSD proposes to locate the proposed recharge facilities within the vicinity of the local groundwater pumping depression identified in previous studies of the Nipomo mesa groundwater basin. As an option under this alternative, NCSD could exchange water rights with Black Lake Golf Course, Black Lake development landscaping, and the Woodlands Golf Course and utilize treated wastewater for irrigation water at these areas.

The proposed groundwater recharge of recycled water within the study limits would not introduce a new supplemental water source from outside the NMMA, however, it would be



intended to provide a means to manage and help stabilize the groundwater basin within the subject area. As proposed, this alternative is intended to function as a groundwater management program and not a true supplemental water alternative.

**Alternative No. 6 (Treated Water Exchange with Agricultural Water Users):** The Southland WWTF provides secondary treatment for a mixture of domestic and industrial wastewater from part of the Nipomo community. This alternative would include a groundwater exchange program involving delivery of recycled water from Southland WWTF to potential agricultural users within the vicinity of the groundwater pumping depression previously identified in the Nipomo Mesa. As directed by NCSD staff, the boundary limits of this alternative include the depressed groundwater basin bounded by the Oceano and Santa Maria River Faults and within the NMMA.

The proposed groundwater exchange of recycled water for agricultural production will not introduce a new supplemental water source from outside the NMMA; however, it will be intended to provide a means to manage and redistribute the water balance within the subject area of the NMMA. As proposed, this scenario will provide for the transfer of a non-potable water source (reclaimed water from Southland WWTF) to potential agricultural users for either direct reuse in irrigation of crops or for percolation and subsequent recovery. In exchange, the groundwater previously pumped by the same agricultural users would either be: (1) directly pumped (at the subject wells) and transmitted for use by NCSD; or (2) indirectly extracted by NCSD at existing or new well locations.

## 2.0 PERMITTING REQUIREMENTS

This section lists and discusses the regulatory agencies that have jurisdiction and their permitting requirements within the area of the water supply alternatives under consideration. Proposed alternatives would require various federal, state, and local approvals, depending on the alternative. Refer to Table 1 for a general list of anticipated permitting agencies that would be involved with permitting one or more alternatives. Presented below is a description of each regulatory agency's anticipated role in review and permitting of the proposed alternatives.

### 2.1 FEDERAL AGENCIES

**United States Army Corps of Engineers (USACE).** The USACE would likely be the lead federal agency for the proposed project for placement of fill (including temporary trench spoils) within navigable waters of the U.S. under Section 404 of the Clean Water Act. The USACE also issues permits for construction of facilities within navigable waters in accordance with Section 10 of the Rivers and Harbors Act of 1899. During review of a permit application, the USACE will consult with the U.S. Fish and Wildlife Service (USFWS) and National Oceanic and Atmospheric Administration, National Marine Fisheries Service (NOAA Fisheries) to identify potential effects to federally-listed endangered and threatened species as required under Section 7 of the Endangered Species Act (ESA). A Biological Assessment would be required as part of this consultation to provide sufficient information for the USACE, USFWS, and NOAA Fisheries to fully determine the project's potential to affect federally-listed threatened or endangered species. A review of potential impacts to cultural or historical resources is coordinated through consultation with the State Historic Preservation Office.

A Jurisdictional Waters of the U.S. survey (wetlands delineation) may also be required to identify wetlands that may be impacted by the project. The USACE's jurisdiction under Section 404 of the Clean Water extends to the ordinary high water mark of a river or stream.

USACE permitting would likely affect Alternatives 1, 2, 3, and 4, wherever new construction of conveyance pipelines or other facilities would impact federal waters. Without more detailed engineering specifications, it is unclear to what extent federal waters may be affected. Depending on the alternative selected for implementation, the proposed project may potentially fall within one or more Nationwide Permits (NWP) developed by the USACE for major routine types of construction projects within federal waters.

**National Oceanic and Atmospheric Administration, National Marine Fisheries Service (NOAA Fisheries).** NOAA Fisheries is responsible for the protection of marine fish and mammal species by administering the regulations listed in the ESA, Marine Mammal Protection Act, and the Magnuson-Stevens Fishery Management and Conservation Act. Based on the preliminary information available, NOAA Fisheries may not be involved for onshore portion of the alternatives unless the selected project would result in disturbance within the Santa Maria River or Nipomo Creek. The USACE would consult with NOAA Fisheries for potential impacts to marine fisheries and marine mammals for an ocean outfall pipeline proposed under alternative Nos. 1 or 2.

**United States Fish and Wildlife Service (USFWS).** The USFWS will be requested to review the project by the USACE with respect to potential impacts to federally-listed threatened

or endangered species. Such consultation will be initiated during the 404 or 10 permit process. Impact of critical habitat may also result in seasonal restrictions and recommendations for habitat restoration. Potential endangered species impacts under alternatives 1 through 4 may include potential takes of listed species known to occur in creeks and wetlands along pipeline routes. Under the Alternative 2 scenario, impacts to water quality or quantity within Oso Flaco Lake or creek could affect habitat. The USFWS would be a key stakeholder in mitigation of potential affects of water withdrawals from the Oso Flaco lake watershed. Additionally, impacts from desalination proposals would be required to avoid takes of habitat or individual Western snowy plover or least tern from proposed seawater intake structures or brine outfall lines.

## 2.2 STATE AGENCIES

**Central Coast Regional Water Quality Control Board (RWQCB).** The RWQCB's primary responsibility is to protect the quality of the surface and groundwater within the Central Coast region for beneficial uses. The duty is carried out by formulating and adopting water quality plans for specific ground or surface water bodies, by prescribing and enforcing requirements on domestic and industrial waste discharges, and by requiring cleanup of water contamination and pollution.

Pursuant to Section 401 of the Clean Water Act, the USACE permit under Section 404 is not active until the State of California first issues a water quality certification to ensure that a project will comply with state water quality standards. The authority to issue water quality certifications in the project area is vested with the RWQCB. All of the considered alternatives would involve construction activities which would expose greater than one acre of disturbed construction area to stormwater runoff, and would require enrolling for coverage under the General Construction Stormwater Permit issued by the State Water Resources Control Board and enforced by the RWQCB.

Alternative No. 1 (Seawater/Cooling Water) would likely include requirement of a National Pollutant Discharge Elimination System/Waste Discharge Requirements (NPDES/WDR) permit from the RWQCB for brine discharge to the ocean associated with any of the three scenarios. Also, Alternative No. 2 (Oso Flaco Agricultural Return Water) may also involve the discharge of treated brine to the ocean, requiring a NPDES/WDR permit from the RWQCB. Brine discharges would be required to meet state and federal water quality standards for ocean disposal in accordance with the California Ocean Plan. Impacts to marine organisms from brine discharge would also be considered a potential significant impact under the CEQA.

**California Coastal Commission.** The California Coastal Commission regulates development activities along California's coastline and within the designated coastal zone under the authority of the California Coastal Act. Within the Nipomo area, the coastal zone boundary extends inland from the coastline to Highway 1. Projects approved by the County within the coastal zone can be appealed to the Coastal Commission for independent review for consistency with the Coastal Act. Additionally, projects with construction activities seaward of mean high tide line or affecting coastal streams or environmental sensitive habitat areas (ESHAs) fall within the Coastal Commission's original jurisdiction and would require a Coastal

Development Permit issued by the Coastal Commission. Alternatives 1 and 2 would be located within the coastal zone and would be subject to Coastal Commission review and approval.

**California State Lands Commission (CSLC).** The CSLC manages the state's submerged tidelands along the California coast from the mean high tide line and seaward for three nautical miles. Construction of facilities within CSLC jurisdiction would require a state lands lease. Approval of the state lands lease is made by the commission, composed of the lieutenant governor, the state controller, and the state finance director. Alternatives 1 and 2 would include ocean outfall structures placed in CSLC jurisdiction and would require a state lands lease.

**California Department of Fish and Game (CDFG).** CDFG administers Section 1600 of the California Fish and Game Code. The regulation requires a Lake or Streambed Alteration Agreement (SAA) between CDFG and the applicant before the initiation of any construction project that will: 1) divert, obstruct, or change the natural flow or the bed, channel, or bank of any river, stream, or lake; 2) use materials from a streambed; or 3) result in the disposal or deposition of debris, waste, or other loose material where it can pass into any river, stream, or lake.

The CDFG also administers a number of laws and programs designed to protect fish and wildlife resources. Principle of these is the California Endangered Species Act of 1984 (CESA - Fish and Game Code Section 2050), which regulates the listing and take of state endangered (SE) and threatened species (ST). Under Section 2081 of CESA, CDFG may authorize the take of an Endangered and/or Threatened species, or candidate species through an Incidental Take Permit. However, plant or animal species that are "Fully Protected" under state law cannot be taken and no Incidental Take Permits may be issued. In the project area, the California least tern, the Southern sea otter, and the white-tailed kite are all fully-protected species.

Alternatives 1, 2, 3, and 4 would likely require SAA permits from the CDFG for pipeline creek crossings. The CDFG is a trustee agency under CEQA, and would likely provide comment on the CEQA document regarding potential project impacts to animal and plant species designated rare, threatened/endangered, or fully-protected status.

**California Department of Health Services (DHS).** DHS is responsible for overseeing the quality of water once it is in storage and distribution systems. DHS oversees the self-monitoring and reporting program implemented by all water purveyors, performs inspections, and assists with financing water system improvements for the purpose of providing safer and more reliable service. A Water Supply Permit Amendment would be required from DHS for any of the alternatives under consideration.

**California Department of Transportation (Caltrans).** Caltrans is responsible for managing California's highway and freeway systems and works collaboratively with local agencies to ensure proper management of local roadway systems. Caltrans reviews all requests from utility companies, developers, volunteers, nonprofit organizations, etc., desiring to conduct various activities within their right-of-way (ROW). Construction activity being proposed along a Caltrans ROW would require a Standard Encroachment Permit from Caltrans prior to project implementation. This could potentially occur with all alternatives except Alternatives 5 and 6.

## 2.3 LOCAL AGENCIES

**County of San Luis Obispo.** All of the alternatives would be within the jurisdiction of San Luis Obispo County land use regulations (SLO County). SLO County will require that a conditional (or minor) use permit, grading permit, and building permit be issued for the construction and operation of the project facilities (i.e. pipelines, wells, and storage) and will analyze the project to determine consistency with any applicable standards or policies. SLO County may impose specific requirements/conditions be incorporated into the permit governing the design or operation of the project and may not approve the permit unless it is found to be consistent with the County's General Plan and Land Use Ordinance. The County would be a permitting agency under CEQA and would rely on the NCS D's CEQA determination in issuance of permits. Encroachment along county roadways would require a standard encroachment permit issued by the County Public Works Department.

**San Luis Obispo County Air Pollution Control District (APCD).** The APCD would review proposed project for compliance with applicable Federal, State and local air quality control criteria. For any of the alternatives, NCS D likely would be required to submit a Construction Activity Management Plan to the APCD which will address construction-related dust control and equipment emissions. The CAMP will be required to address construction-related air impacts through various mitigation techniques. Detailed documentation of proposed project emissions (such as from organics removal during treatment) will be required to obtain Authority to Construct/Permit to Operate permits, if needed.

**San Luis Obispo County Division of Environmental Health.** The County Division of Environmental Health (SLODEH) is the local approval agency for issuance of water supply well permits or injection wells within a drinking water aquifer. Wellhead protection regulations require a minimum separation of water supply wells from wastewater disposal facilities. Under Title 22 regulations, the SLODEH may require any injected water to meet drinking water standards prior to injection.

## 2.4 CALIFORNIA ENVIRONMENTAL QUALITY ACT

The NCS D would act as the lead agency for compliance with the California Environmental Quality Act (CEQA) for implementation of any of the water supply alternatives under consideration. The NCS D would prepare an Initial Study/ Mitigated Negative Declaration (IS/MND) or Environmental Impact Report (EIR) for the selected project, depending on the level of impacts anticipated. During the CEQA process, NCS D would consult with other state and local agencies regarding concerns and suggested mitigation for environmental impacts. Environmental issues that arise during CEQA processes will be addressed through project design modifications or mitigation measures included in the CEQA document. Following completion of the CEQA process, the NCS D would submit permit applications to regulatory agencies as appropriate and negotiate permit conditions as needed.

**Table 1. Permit Requirements Summary**

Agency	Permit/Approval	Regulated Activity	Authority
<b>Federal Agencies</b>			
U.S. Army Corps of Engineers (USACE)	Section 404 permit Section 10 permit	Discharge of dredged or fill material into water of the U.S. during construction. Jurisdictional water include territorial seas, tidelands, rivers, streams, and wetlands	Section 404 Clean Water Act (33 USC 1344). Rivers and Harbors Act
U.S. Fish and Wildlife Service (USFWS)	Endangered Species Act, Section 7 consultation	Impacts to federally-listed species and species proposed for listing.	16 USCA 1513 50 CFR Section 17
NOAA Fisheries	ESA, Section 7 consultation	Impacts to federally-listed species and species proposed for listing.	16 USCA 1513 50 CFR Section 17
<b>State of California Agencies</b>			
Regional Water Quality Control Board	Section 401 Water Quality Certification SWPPP Permit NPDES/WDRs	Discharges that may affect surface and ground water quality.	Clean Water Act Porter-Cologne State Water Quality Act (1969)
California Coastal Commission	Appeal Jurisdiction within Coastal Zone	Projects within Coastal Zone approved by County can be appealed to Coastal Commission for review and approval.	California Coastal Act
California Department of Fish and Game (CDFG)	1602 Permit Section 2081 Management Agreement	Crossing of streams and rivers that will result in disturbance to the streambed. Potential adverse effects to State-listed species	Sections 1601-1607 of California Fish and Game Code. Section 2081 of the Fish and Game Code
California State Lands Commission	State Lands Lease	Project activities offshore of mean high tide line.	California Public Resources Code, Division 6.
California Department of Health Services	Water Supply Permit Amendment	New water source	Ca Health and Safety Code, Div. 104, Part 12, Chapter 4 Article 7, Section 116525
California Department of Transportation	Standard Encroachment Permit	Construction activity within Caltrans right-of-way.	California Streets and Highway Code
<b>Local Agencies</b>			
County of San Luis Obispo Planning and Building Department	Development, Grading, Building Permit	Land use, grading, drainage, encroachment permit	San Luis Obispo County Code
San Luis Obispo APCD	Authority to Construct	Emissions associated with construction may require permits.	Clean Air Act
County of San Luis Obispo Division of Environmental Health	Well Construction Permit	Construction new water supply wells	California Water Code

## 3.0 ENVIRONMENTAL CONSTRAINTS

The following section describes the potential environmental constraints associated with the six water supply alternatives under consideration by the NCSA. Based on Padre's initial review of the project alternatives and review of permitting requirements, the probable issues that will need to be addressed during the permitting process for this project are biological resources including wetlands, cultural resources, geology and soils, and hydrology/ water quality. The following provides an overview of the environmental issue areas with emphasis on the sensitive biological resources that are expected to occur within the project area due to the presence of suitable habitat. The resources and required mitigation, if any, will be the focus of the respective regulatory agency review during the permit acquisition phase of the project.

### 3.1 BIOLOGICAL RESOURCES

Padre conducted a desk-top review to determine potential biological resource constraints within the vicinity of the identified water supply alternative location. This review included a query of the California Natural Diversity Database (CNDDDB [CNDDDB, 2006]) for the purposes of identifying documented occurrences of special-status plant and animal species within the vicinity of the alternative projects. Figures 2 through 5 illustrate the known occurrences of special-status species in relationship to the water supply alternatives under consideration. The figures illustrate a representative sample or ranges for known species occurrences.

#### 3.1.1 Federally-Listed Animal Species

**California red-legged frog (*Rana aurora draytonii*).** The California red-legged frog (CRLF) is a federally-listed threatened species and a California species of special concern. The CRLF occurs in different habitats depending on their life stage and season. CRLF breed from November through March. All stages are most likely to be encountered in and around breeding sites, which include marshes, springs, permanent and semi-permanent natural ponds, ponded and backwater portions of streams, as well as artificial impoundments such as stock ponds, irrigation ponds, and siltation ponds. This species prefers dense emergent and bank vegetation including willow (*Salix* sp.), cattail (*Typha* sp.), and bulrush (*Scirpus* sp.). The absence of these plant species within the site does not exclude the possibility that the site provides CRLF habitat, but the presence of one or all of these plants is an important indicator that the site may provide foraging or breeding habitat (USFWS, 2005).

CRLF is a concern for alternatives 1, 2, and 4 due to the known presence or suitable habitat in creeks and wetlands within the project Nipomo area, especially around Oso Flaco Lake and Oso Flaco Creek. As such, formal Section 7 consultation pursuant to Section 404 of the Clean Water Act would be useful between the USACE and the USFWS to further assess potential CRLF impacts due to project implementation and the need for project-specific avoidance and minimization measures. This would include preparation of a Biological Opinion (BO) by the USFWS which will ultimately result in approval for authorized individuals to survey for and, as necessary, relocate CRLF from the project area during project implementation (i.e., "Take Statement").

**Steelhead – Southern California ESU (*Oncorhynchus mykiss irideus*).** Steelhead have been divided into 15 evolutionary significant units (ESU) based on similarity in life history, location, and genetic markers. The Southern California ESU was listed as federally endangered by the NOAA Fisheries in 1997. Southern California steelhead is also a California species of special concern. Steelhead are an anadromous form of rainbow trout that reproduce in freshwater, but spend much of their life cycle in the ocean, where increased prey density provides a greater growth rate and size. The Southern California ESU includes all naturally spawned populations of steelhead (and their progeny) in streams from the Santa Maria River (inclusive) to the southern extent of the species' range (U.S. – Mexico border). Historical information suggests that the Santa Maria River supported a steelhead run in the early 1900s. Currently, there is no evidence suggesting presence of this species in the Santa Maria River for several decades. However, it is assumed this species has the potential to occur within the Santa Maria River during periods of adequate flow (i.e., January through April).

Steelhead may not be a significant species of concern for the alternatives under consideration unless there would be an affect to the Santa Maria River. Existing fish migration barriers that exist at Nipomo Creek currently impede migration of steelhead upstream of the Hutton Road area. As part of the USACE permit process, Section 7 consultation per the ESA will be conducted with NOAA Fisheries to further assess potential steelhead impacts due to project implementation and the need for project-specific avoidance and minimization measures.

**Western Snowy Plover (*Charadrius alexandrinus*).** The coastal population of nesting western snowy plover is federally-listed threatened species and a California species of special concern. The western snowy plover frequents sandy beaches and estuarine shores within the project site; requiring sandy, gravely or friable soil substrates for nesting. Western snowy plover breeding and nesting is currently being monitored by State Parks as part of their ongoing efforts to document snowy plover activity within the area. Plovers are known to occur in suitable habitat areas from Guadalupe Dunes to Pismo Beach. This species would be of concern for alternative Nos. 1 and 2 associated with any construction activities within Nipomo-Guadalupe dune complex.

**California Least Tern (*Sterna antillarum brownii*).** The California least tern is a migratory bird that is protected under both the provisions of the federal and California endangered species acts as endangered. Many areas of coastal habitat for the California Least Tern have been significantly modified by human activities, such as marinas and industrial development, and housing. Other threats to tern populations include increased predation (a result of anthropogenic factors and habitat modification), potential for washouts by significantly high tides, and recreation. Least tern spring migrants arrive and move through the area around the latter part of April. Egg-laying usually occurs at most of the sites by late May, with hatching chicks present in mid June. Least tern are known to occur in suitable habitat areas from Guadalupe Dunes to Pismo Beach.

### 3.1.2 Special-Status Plants

**Gambel's water cress (*Rorippa gambellii*).** Gambel's watercress is a federally and state-listed endangered species in the mustard family (Brassicaceae). Gambel's water cress occurs in freshwater or brackish marshes and swamps between 5 and 330 meters. This



species typically blooms from April to September. Gambel's water cress is known to occur in only four remaining locations in California.

**La Graciosa thistle (*Cirsium loncholepis*).** La Graciosa thistle is a federally endangered, state threatened species, and a CNPS List 1B species. This species is a perennial herb in the sunflower family (Asteraceae) that typically blooms May through August. La Graciosa thistle occurs in coastal dunes, brackish marshes, or riparian scrub often in association with lake edges, riverbanks, and other wetlands.

**Nipomo Mesa lupine (*Lupinus nipomensis*).** Nipomo Mesa lupine is an annual herb in the pea family (Fabaceae) that occurs in coastal dune habitat between 10 and 50 meters. This species typically blooms from December through May. Nipomo Mesa lupine is a federally endangered, state threatened species, and a CNPS List 1B species. This species is known from only one extended occurrence of five populations on Nipomo Mesa in San Luis Obispo County.

**San Luis monardella (*Monardella frutescens*).** San Luis monardella is a rhizomatous herb in the mint family (Lamiaceae). San Luis monardella is a CNPS List 1B species that is known to occur in San Luis Obispo and Santa Barbara Counties. This species inhabits coastal dunes and coastal scrub habitat associated with sandy soils between 10 and 200 meters. San Luis monardella generally blooms from May to September.

**Blochman's leafy daisy (*Erigeron blochmaniae*).** Blochman's leafy daisy is a rhizomatous herb in the sunflower family (Asteraceae) known to occur in San Luis Obispo and Santa Barbara Counties. Blochman's leafy daisy is a CNPS List 1B species. This species typically blooms from June through August and occurs in coastal dune and coastal scrub habitat between 3 and 45 meters.

**Dune larkspur (*Delphinium parryi* ssp. *blochmaniae*).** Dune larkspur is a CNPS List 1B species known to occur in San Luis Obispo, Santa Barbara, and Ventura Counties. This species is a perennial herb in the buttercup family (Ranunculaceae) that inhabits coastal dune and chaparral habitat between 0 to 200 meters. Dune larkspur generally blooms from April through May.

### 3.1.3 Other Potentially Occurring Special-Status Species

Although species described in this section are not indicated on the occurrences maps included (Figures 2 – 5), they have been included based on their occurrences within the Nipomo area.

**Coast horned lizard (*Phrynosoma coronatum frontale*).** The coast horned lizard is a federal species of concern and a California species of special concern that occurs in a variety of open habitats that provide sites for basking, sandy or sandy-loam substrates for night-time burial, and a suitable prey base (the species feeds almost exclusively on native ants). It was historically distributed throughout the Central and Coast Range of California, but now occurs at scattered, disjunct locations within this former range. The coast horned lizard produces clutches of 6 to 21 eggs from May to June and hatching typically occurs in August through September. A single coast horned lizard was observed within the non-native grassland/coastal sage scrub habitat area along the south side of the Santa Maria River in 2005 (Douglas Wood &

Associates, Inc., 2006). The coast horned lizard has the potential to occur throughout the Nipomo area. As such, mitigation to avoid and/or minimize impacts to coast horned lizard during project implementation would be determined during consultation with CDFG.

**Southwestern pond turtle (*Clemmys marmorata pallida*).** The southwestern pond turtle is a federal species of special concern and a California species of special concern. It is an aquatic turtle inhabiting streams, marshes, ponds, and irrigation ditches within woodland, grassland, and open forest communities. However, it requires upland sites for nesting and over-wintering. Stream habitat must contain large, deep pool areas (six feet) with moderate-to-good plant and debris cover, and rock and cobble substrates for escape retreats. Southwestern pond turtle was observed in Nipomo Creek during a reconnaissance-level survey conducted by Padre in July 2004. Therefore, it has been determined that this species has the potential to occur within Nipomo Creek area during implementation, including portions of the Santa Maria River. As such, mitigation to avoid and/or minimize impacts to southwestern pond turtle during project implementation would be determined during consultation with USFWS and CDFG.

**Two-striped garter snake (*Thamnophis hammondi*).** The two-striped garter snake is a California species of special concern which is highly aquatic and is typically found near permanent fresh water streams associated with willow habitat. This species occurs historically and currently throughout southern California streams, including the central coast. Small mammal burrows are used as over-wintering sites for the snake (Jennings, 1994). This species has the potential to occur within Nipomo Creek. Mitigation to avoid and/or minimize impacts to two-striped garter snake during project implementation would be determined during consultation with CDFG.

**Blochman's ragwort (*Senecio blochmaniae*).** Blochman's ragwort is a CNPS list 4 species. This species typically occurs in coastal dunes and coastal floodplains. Blochman's ragwort is a subshrub, perennial herb that blooms from May to October. A sparsely scattered population of this species (<50) was identified by Padre in 2004 within the northern sand banks of the Santa Maria River channel, directly adjacent to the existing concrete processing facility located directly west of Highway 101. Suitable habitat for this species exists along the Santa Maria River corridor. Measures to avoid and/or mitigate impacts to Blochman's ragwort would be determined during consultation with CDFG.

**Nuttall's milk-vetch (*Astragalus nuttallii* var. *nuttallii*).** Nuttall's milk vetch is a CNPS list 4 species, which was identified in the project area during the 2005 biological survey of the project area (Douglas Wood & Associates, Inc., 2006). Both locations were along the southern levee of the Santa Maria River within the disturbed grassland and coastal sage scrub habitat areas. Suitable habitat for this species exists along the Santa Maria River corridor. Measures to avoid and/or mitigate impacts to Nuttall's milk-vetch would be determined during consultation with CDFG.

**Monarch Butterfly (*Danaus plexippus*).** The Monarch butterfly does not have federal or state listing status, but is included as a sensitive species by the CNDDDB and is a species of local concern in San Luis Obispo County. Winter roost sites extend from Northern Mendocino to Baja California, Mexico. The listing by CDFG is based on limited wintering roost sites within the Central California coast portion of the butterfly's West Coast wintering range. The Monarch butterfly can be found in a variety of habitats, especially those supporting milkweed plants

(*Asclepias* sp.), the primary food source of the caterpillars. These butterflies frequent grasslands, prairies, meadows, and wetlands, but avoid dense forests. In the winter, Monarchs cluster together in large numbers in eucalyptus, cypress, and Monterey pine trees, often on the edge of open areas. Measures to avoid and/or minimize impacts to Monarch butterflies and/or pre-activity surveys would be determined during the CEQA process and consultation with CDFG.

**Raptor and Migratory Bird Species.** Raptor and migratory bird species protected under the Migratory Bird Treaty Act (16 USC 703-712); CDFG Code Section 3503, and CDFG Code Section 3503.5 may nest within the area during project implementation. These include ground nesters (western meadowlark and lark sparrow), small tree/shrub nesters (bushtit, American robin, northern mockingbird, loggerhead shrike, house finch, and lesser goldfinch) and several raptors which require large trees, such as eucalyptus for nesting purposes (turkey vulture, red-tailed hawk, red-shouldered hawk, great-horned owl, barn owl, white-tailed kite and Cooper's hawk). Short-term impacts to these species may occur from vegetation clearing, debris removal, trenching and HDD operations, dust deposition and noise disturbance associated with the construction activities. Vegetation removal and subsequent grading activities may destroy nests, nestlings, or hatchlings of these protected bird species, and would be considered a significant impact. As such, measures, such as seasonal constraints and/or pre-activity nesting bird surveys to avoid and/or minimize impacts to raptors and migratory birds, would be determined during the CEQA process and consultation with CDFG.

### 3.2 WETLANDS/WATERS OF THE U.S.

The USACE is responsible for the issuance of permits for the placement of dredged or fill material into waters of the United States (waters) pursuant to Section 404 of the Clean Water Act (33 USC 1344). As defined by the USACE at 33 CFR 328.3(a)(3), waters are those that are currently used, or were used in the past, or may be susceptible to use in interstate or foreign commerce, including all waters that are subject to the ebb and flow of the tide; tributaries and impoundments to such waters; all interstate waters including interstate wetlands; and territorial seas. (Note: Based on the recent U.S. Supreme Court decision in *Solid Waste Agency of Northern Cook County v. U.S. Army Corps of Engineers* [2001], and guidance from the U.S. Army Corps of Engineers and U.S. Environmental Protection Agency [2001], the Federal government no longer asserts jurisdiction over isolated waters and wetlands under Section 404 of the Clean Water Act based on the "migratory bird rule." Further guidance on the issue of isolated wetlands and waters is expected (U.S. Army Corps of Engineers, 2001).

Wetlands are a special category of waters, and are defined at 33 CFR 328.3(b) as: "...those areas that are inundated or saturated by surface or groundwater at a frequency and duration sufficient to support, and that under normal circumstances do support, a prevalence of vegetation typically adapted for life in saturated soil conditions. Wetlands generally include swamps, marshes, bogs, and similar areas."

In non-tidal waters, the lateral extent of USACE jurisdiction is determined by the ordinary high water mark (OHWM), which is defined as the: "...*line on the shore established by the fluctuations of water and indicated by physical characteristics such as clear, natural line impressed on the bank, shelving, changes in the character of soil, destruction of terrestrial*

*vegetation, the presence of litter and debris, or other appropriate means that consider the characteristics of the surrounding areas.” (33 CFR 328[e]).*

In addition, a wetland definition has been adopted by the USFWS to include both vegetated and non-vegetated wetlands, recognizing that some types of wetlands may lack vegetation (e.g., mudflats, sandbar, rocky shores, and sand flats), but still provide functional habitat for fish and wildlife species (Cowardin, et al., 1979). These wetlands are defined as “...lands transitional between terrestrial and aquatic systems where the water table is usually at or near the surface or the land is covered by shallow water. For purposes of this classification, wetlands must have one or more of the following three attributes: (1) at least periodically, the land supports predominantly hydrophytes; (2) the substrate is predominantly undrained hydric soil; and (3) the substrate is non-soil and is saturated with water or covered by shallow water at some time during the growing season of each year.” Some of the USFWS-defined wetlands are not regulated by the Federal government.

The upper (landward) limit of USFWS-defined wetlands are the boundary between land with predominantly hydrophytic cover and land with predominantly mesophytic or xerophytic cover; the boundary between soil that is predominantly hydric and soil that is predominantly non-hydric; or in the case of wetlands without vegetation or soil, the boundary between land that is flooded or saturated at some time each year and land that is not (Cowardin et al., 1979). The lower limit in inland areas is established at a depth of 6.6 feet below the water surface; unless emergent plants, shrubs, or trees grow beyond this depth, at which the deepwater edge of such vegetation is the boundary (Cowardin et al., 1979).

Based on the definitions above, both waters of the U.S. and USACE-defined wetlands are present within the Santa Maria River floodplain, Nipomo Creek, and the Oso Flaco Lake and Oso Flaco Creek areas. Oso Flaco Lake occupies a surface area of 82 acres is classified by the USFWS as a palustrine emergent wetland. Additionally, several of the nearby drainages and associated storage ponds that act as tributaries to Nipomo Creek and the Santa Maria River, such as those occurring along the Nipomo Mesa have the potential to fall under the USACE jurisdiction. Wetlands and creeks impacted by pipeline installation activities would need to be restored or replaced. In the event a selected alternative would affect designated wetlands, an agency-approved Wetlands Mitigation and Monitoring Plan would need to be implemented as part of the project.

### **3.3 CULTURAL RESOURCES**

Alternatives involving construction activities and placement of project-related infrastructure (i.e. pipelines, tanks, treatment plants) would require evaluation and analysis of the potential for effect on culturally-sensitive resources. Alternatives would require delineation of pipeline routes and placement of project facilities prior to implementing cultural records searches and/or surveys. The Dana Adobe, located on South Oakglen Avenue, is a designated California Historical Landmark. Sensitive cultural sites are known to exist near the Dana Adobe in eastern Nipomo.

### 3.4 GEOLOGY AND SOILS

The information discussed in this section was determined through a review of the San Luis Obispo County Safety Element (1998). Depending on jurisdiction, project alternatives would be reviewed for geologic (e.g. active faults, liquefaction) and other safety issues. Within the general project area (i.e. south-western San Luis Obispo County and the Santa Maria area), there is a potentially active fault (Santa Maria River Fault) and areas of moderate to high liquefaction, particularly in the coastal dune areas around Oso Flaco Lake. Areas located within 100-year flood plain zones include the Santa Maria River and the Oso Flaco Lake area. This area is also considered a “dam inundation zone”. Additionally, areas east of the Guadalupe-Nipomo Dunes Complex (e.g. Conoco-Phillips Refinery, Nipomo) are subject to substantial wildland fire risk. Although no specific permits may be required in relation to these hazards, the projects will be reviewed for land-use policy consistency during the CEQA and County permitting process.

### 3.5 HYDROLOGY AND WATER QUALITY

**Water Quality.** It is Padre’s understanding that Boyle will provide the NCSO with an assessment of water quality issues associated with the development of the water supply alternatives and provision of potable water in accordance with state and federal water quality standards within a separate document. The following discussion focuses on water quality and hydrologic impacts that may arise from the construction of each of the water supply alternatives. Water quality impacts would be connected to construction site erosion/spills/etc, frac-outs (as discussed), and discharges from each alternative. Hydrologic impacts would be due to extractions from certain sources and discharges to certain locations.

With increased development and storm water runoff, a wide variety of nutrients and constituents of concern have been introduced into state waters. Nutrient wastes in the form of sewage, agricultural fertilizers, and manure lead to reduced dissolved oxygen in surface waters and limit the capacity of water to support aquatic organisms. Constituents of concern, such as industrial wastes, insecticides, and herbicides, can poison wildlife and become concentrated in the food chain.

Oso Flaco Lake and Oso Flaco Creek has been identified by the RWQCB as an “impaired water body” under Section 303d of the Clean Water Act because of elevated levels of nitrates associated with irrigated agriculture within the watershed. Oso Flaco Creek is also listed as an impaired water body for elevated fecal coliform bacteria concentrations. Restoration of water quality at Oso Flaco Lake by the RWQCB has focused primarily on agricultural return water quality and quantity (RWQCB, 2006). Additionally, Nipomo Creek has been designated an “impaired water body” under Section 303d because of elevated fecal coliform bacteria concentrations.

**HDD Drilling Techniques.** Horizontal directional drilling (HDD) techniques involve the installation of pipelines without open-trenching. HDD installation methods are environmentally-preferable to open-trenching in most cases because it can be utilized to avoid impacts to sensitive resources such as creeks and wetlands. “Frac-outs”, or the loss of drilling fluids to the surrounding environment, are a risk in utilizing HDD drilling techniques. The potential for “frac outs” should be minimized by incorporating engineering and geologic information and

developing a drilling and drilling fluid monitoring program that is appropriate for the existing subsurface geological conditions. The HDD drilling plans should specify drilling parameters such as drilling equipment capacity, directional bore depths, entry, and exit angles. Drilling fluid properties including fluid weight, viscosity, water loss, and gel strength should be designed and monitored by a qualified engineer. Only bentonite-based drilling mud is allowed for use within state waters in California. Compounds that may be toxic to fish are prohibited from use as additives to drilling mud mixtures.

## 4.0 SUMMARY AND RECOMMENDATIONS

The following section provides a summary of the permitting issues and requirements for the water supply alternatives under consideration by the NCSO. A summary of the permitting requirements is presented in Table 2, followed by general recommendations on a permitting strategy.

### 4.1 SUMMARY OF ENVIRONMENTAL/PERMITTING ISSUES BY ALTERNATIVE

The following provides an overview of the expected agency jurisdictional issues and associated permits that may be required for the various water supply alternatives:

**Alternative No. 1 (Seawater/Cooling Water):** Although specific locations are not identified under this alternative, proposals for desalination facilities along California's coast have raised unique issues that would need to be addressed through project design and agency negotiations. The California Coastal Commission has raised concerns about brine disposal impacts to marine resources. Open seawater intakes structures have been effectively prohibited by the Coastal Commission due to entrainment and take of marine organisms. One method of mitigating concerns associated with desal intake system construction within the beach areas would be to utilize existing intake structures or outfall pipelines. As a result of concerns about open ocean intake pipelines, most desalination facilities currently under consideration along the Central and South Coasts of California include beach water intake systems that utilize wells or intake galleries that would draw brackish water from permeable zones within the coastline and beach areas.

The design of a beach well intake system can result in a separate set of environmental impacts. The Nipomo-Guadalupe Dune complex is a unique and sensitive area that has been heavily protected by land acquisition, land use planning, and regulatory activities. Numerous threatened or endangered species, such as the Western snowy plover and the California least tern, are present within the dune complex and along the beach areas of the Nipomo-Guadalupe dunes.

The area around the Conoco-Phillips refinery is known to contain special-status plant species (e.g. Nipomo Mesa Lupine, La Graciosa Thistle, Dune Larkspur), as well as sensitive habitat (Central Coast Dune Scrub).

Selection of one of the seawater or cooling water alternatives will require review and approval of a Coastal Development Permit by the County of San Luis Obispo which would be appealable to the Coastal Commission. The State Lands Commission would require a state lands lease for placement of an ocean outfall line in state waters. The ocean outfall line would also require a Section 404/10 permit from USACE for construction in navigable waters. Pipeline

facilities associated with any of the options would likely require permits from the USACE, RWQCB, and CDFG for pipeline creek crossings. A Caltrans encroachment permit would be required for pipeline crossings at Highway One. A RWQCB NPDES/WDR permit would be required for the disposal of brine into the Pacific Ocean or other form of injection or disposal options that may affect surface or ground water quality.

**Alternative No. 2 (Oso Flaco Lake Watershed):** This alternative would involve treating shallow groundwater or agricultural runoff within the Oso Flaco Lake watershed and delivering the treated water to the NCS D distribution system. This alternative may include returning a portion of the treated flow to the watershed for environmental uses.

The Oso Flaco Creek Watershed covers approximately 10,370 acres. The western terminus for the watershed is Oso Flaco Lake, owned by California State Parks. Oso Flaco Creek flows out of the lake and meanders ¼-mile to the Pacific Ocean through active sand dunes. Oso Flaco Lake is the largest of four small freshwater lakes located in the Guadalupe Nipomo Dunes Complex. The freshwater lake occupies a surface area of 82 acres and is classified by the U.S. Fish and Wildlife Service as palustrine emergent wetlands, a valuable habitat for wildlife, and subsequently a resource for many recreational and educational activities.

Oso Flaco Lake and Little Oso Flaco Lake are usually at maximum pool due to the steady flow of agricultural runoff. It has been estimated that 6,371 acres in the watershed are irrigated, primarily with pumped groundwater, and that 17,564 acre-feet per year (AFY) of water are applied, resulting in 968 AFY of agricultural runoff. Efforts are currently underway to improve irrigation efficiency to both reduce the quantity of water applied and the volume of agricultural runoff. It has been estimated that if 100% of the irrigated area were to adopt sprinkler/drip systems, the annual runoff volume would decrease to 440 AFY (CRCD, 2004).

The critical environmental issue associated with this alternative is ensuring that significant negative impacts would not occur to Oso Flaco Lake, Little Oso Flaco Lake or associated creeks. Impacts would be considered significant if less environmental flows to the creeks and lakes would result in reduced habitat for endangered species. The County of San Luis Obispo has designated Oso Flaco Lake as a Sensitive Resource Area in its South County Coastal Area Plan (1988). Activities within Sensitive Resource Areas are required to undergo extra scrutiny to ensure that damage to the resource will not result from proposed projects. Hydrologic modeling of the watershed would be required to show that water levels within the lakes would not be significantly affected through water withdrawal upstream. A project that improves water quality in Oso Flaco Lake could be leveraged as a desirable outcome for stakeholders in the area, including State Parks, RWQCB, USFWS, CDFG, the Dunes Center, and agricultural water users.

This alternative project would require review and approval of Coastal Development Permits by the County of San Luis Obispo and the Coastal Commission for the outfall line extending into the ocean. The State Lands Commission would require a state lands lease for placement of an ocean outfall line. The ocean outfall line would also require a Section 404/10 permit from USACE for construction in navigable waters. Pipeline facilities associated with any of the options would likely require permits from the USACE, RWQCB, and CDFG for pipeline creek crossings. A Caltrans encroachment permit would be required for pipeline crossings at Highway One. A RWQCB NPDES/WDR permit would be required for the disposal of brine into

the Pacific Ocean or other form of injection or disposal options that may affect surface or ground water quality.

Formal Section 7 consultation would be required with the USFWS due to the presence of CRLF within the Oso Flaco Creek area. NOAA Fisheries would be consulted by the USACE for potential impacts associated with an ocean outfall to marine fisheries and marine mammals. The level of disturbance during construction of pipelines to environmentally sensitive areas could be minimized through the use of HDD construction techniques.

**Alternative No. 3 (Water Trading with CCWA Agencies):** This alternative would consider acquisition of unused capacity in the State Water Pipeline (SWP) from one or more CCWA project participants, including acquiring exchange water from one or more CCWA project participants. Water could be provided via a turnout along the State Water Pipeline within the NCSO boundary. This water would then either be delivered directly to the NCSO water system, or indirectly via aquifer storage and recovery.

As new construction activities would be minimal with this alternative, agency jurisdictional issues would be less than other alternatives. The use of a CCWA interconnection at the Tefft Street site may require a pipeline crossing at Nipomo Creek. If it can be determined that creek and wetland crossings can be avoided, USACE, RWQCB, and CDFG permits would not be required. Furthermore, impacts to special-status wildlife and plants could be minimized if construction is limited to disturbed and developed areas. NOAA Fisheries most likely will not be a key permitting agency under this alternative provided that surface water flows within the Santa Maria River are not affected. Existing fish passage barriers in Nipomo Creek have almost eliminated the likelihood of steelhead in Nipomo Creek. A Caltrans encroachment permit would be required for a pipeline crossing at Highway 101, if required.

Recent litigation regarding the State Water Project's Harvey O. Banks intake facility have included the judge's threat to require the California Department of Water Resources (DWR) to stop pumping water from the delta. The main issue centers around fish takes that are have not been permitted by the USFWS and NOAA Fisheries under the Endangered Species Act. It is Padre's understanding that CDFG and DWR are in negotiations with NOAA Fisheries and the USFWS which may result in an agreement being enacted to allow continued water withdrawals from the delta area with allowed incidental take of fish species.

**Alternative No. 4 (Santa Maria Groundwater):** This alternative would include the development of wells at either the Hutton Road area or at the Bonita well site to extract groundwater, which then would be conveyed to NCSO through a pipeline. Selection of one of the seawater or cooling water alternatives will require review and approval of a discretionary development permit by the County of San Luis Obispo. Pipeline facilities associated with any of the options would likely require permits from the USACE, RWQCB, and CDFG for any pipeline creek crossings. A Caltrans encroachment permit would be required for pipeline crossings at Highway 101, if crossed. NOAA Fisheries most likely will not be a key permitting agency under this alternative provided that surface water flows within the Santa Maria River are not affected. Existing fish passage barriers in Nipomo Creek have almost eliminated the likelihood of steelhead in Nipomo Creek.



**Alternative No. 5 (Groundwater Recharge from Wastewater Treatment Facility):**

This alternative would include the construction groundwater recharge facilities within a specified area where groundwater depressions are known. This alternative would require a discretionary permit from the County of San Luis Obispo for the construction of water transmission and disposal facilities. It is anticipated that pipeline alignments associated with this alternative could be designed to avoid wetlands and sensitive habitat areas through environmental planning and site design. It is also anticipated that wetland and creek pipeline crossings would not be required for this alternative. A WDR permit modification from the RWQCB would be required for the disposal of treated wastewater at the proposed recharge facilities. No Caltrans encroachment permit would be required if conveyance facilities did not cross Highways 1 or 101.

**Alternative No. 6 (Treated Water Exchange with Agricultural Water users).**

This alternative would include an exchange of treated wastewater for agricultural water within a specified area where groundwater depressions are known. This alternative would require a discretionary development permit from the County of San Luis Obispo for the construction of water transmission and storage facilities. It is anticipated that pipeline alignments associated with this alternative could be designed to avoid wetlands and sensitive habitat areas through environmental planning and site design. It is also anticipated that wetland and creek pipeline crossings would not be required for this alternative. A WDR permit modification from the RWQCB would be required for the beneficial re-use of treated wastewater at the proposed agricultural lands. No Caltrans encroachment permit would be required if conveyance facilities did not cross Highways 1 or 101.

## **4.2 GENERAL RECOMMENDATIONS**

**Biological Resources.** The preliminary review of the project alternatives identified potential constraints related to habitat for protected species within the Oso Flaco Lake, Nipomo-Guadalupe Dunes and other wetland/creek areas in the project area. The following are recommendations to minimize impacts to biological resources:

- Complete required CRLF protocol-level surveys during the CRLF breeding season (January 1 through June 30) to identify all known populations of CRLF within the limits of the project boundary and nearby areas. This would be accomplished once project alternative details and engineering specifications can clearly define areas of potential impact. As an example, potential impacts to the CRLF and associated habitat areas can be avoided and/or minimized through additional pipeline-route deviations and/or adjustments.
- Where necessary, the use of HDD construction methods across creeks and streams would minimize impacts to wetland/ jurisdictional waters and special-status species with the potential to occur in the area.
- Rare plant species (e.g. Nipomo Mesa Lupine, La Graciosa Thistle, Dune Larkspur) are located within the vicinity of Oso Flaco Lake and the Conoco-Phillips Refinery. Coastal Dune Scrub, considered a sensitive habitat, is common in this area. Botanical surveys may be needed to determine the likelihood of impacts within any final selected pipeline alignments, or other treatment plant facilities. Impacts to rare

plants may be avoided through route-deviations or other strategic placement as feasible, and/or through seed collection and restoration, as necessary.

**Wetlands/Waters of the U.S.** A high-level preliminary review of the project alternatives and site survey(s) conducted to date identified potential constraints related to regulated waters of the U.S. and wetlands. Following are recommendations to minimize impacts to wetlands and Waters of the U.S.:

- Where necessary, the use of HDD construction methods across creeks and streams would minimize impacts to wetland/ jurisdictional waters and special-status species with the potential to occur in the area.
- Whenever possible, limit construction activities to within previously disturbed or developed areas to avoid impacting sensitive habitat areas. A wetland delineation may be required to determine the likelihood of impacts to identified wetlands within final selected pipeline alignments and other impacted areas.
- “Frac-outs”, or the loss of drilling fluids to the surrounding environment, and potential release of drilling mud into sensitive aquatic areas, are considered serious offenses by regulatory agencies. The potential for “frac-outs” should be minimized by incorporation of engineering and geologic information and development of a drilling and drilling fluid monitoring program that considers the existing geological conditions.
- Creek crossings and/or HDD operations may be limited by CDFG, RWQCB, and NOAA Fisheries to April 15 through October 15 to avoid impacts to water quality and associated sensitive species.

**Cultural Resources.** Alternatives involving construction activities and placement of project-related infrastructure (i.e. pipelines, tanks, treatment plants) would require evaluation and analysis of the potential for effect on culturally-sensitive resources. Alternatives would require delineation of pipeline routes and placement of project facilities prior to implementing cultural records searches and visual survey.

**Table 2. Matrix of Required Permits by Alternative**

Alternatives/Options	USACE – 404/10 Permit	USFWS – Section 7	NOAA Fisheries – Section 7	California Coastal Commission Appeal Jurisdiction	California State Lands Commission	CDFG- SAA	Regional Water Quality Control Board (RWQCB) – 401 Cert.	RWQCB – NPDES/WDR	RWQCB - SWPPP	DHS –Water Supply Permit	Caltrans – Encroachment Permit	County of San Luis Obispo Permits	SLO APCD – Authority to Construct	SLO Environmental Health	Relative Difficulty for Permitting (Low to High)	Biological-related mitigation Required (H=High, L=Low)	Permitting Time Requirement
Alternative 1 – Seawater/Cooling Water Treatment	<input checked="" type="checkbox"/>	<input checked="" type="checkbox"/>	<input checked="" type="checkbox"/>	<input checked="" type="checkbox"/>	<input checked="" type="checkbox"/>	<input checked="" type="checkbox"/>	<input checked="" type="checkbox"/>	<input checked="" type="checkbox"/>	<input checked="" type="checkbox"/>	<input checked="" type="checkbox"/>	<input checked="" type="checkbox"/>	<input checked="" type="checkbox"/>	<input checked="" type="checkbox"/>	<input checked="" type="checkbox"/>	H	H	24-36 mos.
Alternative 2 – Oso Flaco Agricultural Water	<input checked="" type="checkbox"/>	<input checked="" type="checkbox"/>	<input checked="" type="checkbox"/>	<input checked="" type="checkbox"/>	<input checked="" type="checkbox"/>	<input checked="" type="checkbox"/>	<input checked="" type="checkbox"/>	<input checked="" type="checkbox"/>	<input checked="" type="checkbox"/>	<input checked="" type="checkbox"/>	<input checked="" type="checkbox"/>	<input checked="" type="checkbox"/>	<input checked="" type="checkbox"/>	<input checked="" type="checkbox"/>	H	H	24-36 MOS
Alternative 3 – Water trading with CCWA agencies	<input checked="" type="checkbox"/>	<input checked="" type="checkbox"/>	<input checked="" type="checkbox"/>	<input type="checkbox"/>	<input type="checkbox"/>	<input checked="" type="checkbox"/>	<input checked="" type="checkbox"/>	<input type="checkbox"/>	<input checked="" type="checkbox"/>	<input checked="" type="checkbox"/>	<input checked="" type="checkbox"/>	<input checked="" type="checkbox"/>	<input type="checkbox"/>	<input type="checkbox"/>	L	L	12-18 MOS
Alternative 4 – Santa Maria Groundwater	<input checked="" type="checkbox"/>	<input checked="" type="checkbox"/>	<input checked="" type="checkbox"/>	<input type="checkbox"/>	<input type="checkbox"/>	<input checked="" type="checkbox"/>	<input checked="" type="checkbox"/>	<input type="checkbox"/>	<input checked="" type="checkbox"/>	<input checked="" type="checkbox"/>	<input type="checkbox"/>	<input checked="" type="checkbox"/>	<input type="checkbox"/>	<input checked="" type="checkbox"/>	L	L	12-24 MOS
Alternative 5 – Groundwater Recharge with Treated Water from Southland WWTF	<input type="checkbox"/>	<input type="checkbox"/>	<input type="checkbox"/>	<input type="checkbox"/>	<input type="checkbox"/>	<input type="checkbox"/>	<input type="checkbox"/>	<input checked="" type="checkbox"/>	<input checked="" type="checkbox"/>	<input checked="" type="checkbox"/>	<input type="checkbox"/>	<input checked="" type="checkbox"/>	<input type="checkbox"/>	<input checked="" type="checkbox"/>	L	L	12 MOS
Alternative 6 – Agricultural Water Exchange	<input type="checkbox"/>	<input type="checkbox"/>	<input type="checkbox"/>	<input type="checkbox"/>	<input type="checkbox"/>	<input type="checkbox"/>	<input type="checkbox"/>	<input checked="" type="checkbox"/>	<input checked="" type="checkbox"/>	<input checked="" type="checkbox"/>	<input type="checkbox"/>	<input checked="" type="checkbox"/>	<input type="checkbox"/>	<input type="checkbox"/>	L	L	12 MOS



## 5.0 REFERENCES

- Cachuma Resource Conservation District and the Dunes Center. 2004. Draft Nitrate and Sediment Assessment, Oso Flaco Watershed, San Luis Obispo County, California. Report prepared for California Regional Water Quality Control Board, Central Coast Region, August.
- California Natural Diversity Database, 2006. Rarefind 3 Query. California Department of Fish and Game. Sacramento, Ca.
- County of San Luis Obispo, Safety Element, 1998.
- Cowardin, Lewis M., V. Carter, F.C. Golet, and E.T. LaRoe, 1979. *Classification of Wetlands and Deepwater Habitats of the United States*. U.S. Fish and Wildlife Service. Washington, D.C.
- Douglas Wood and Associates, Draft Environmental Impact Report for Nipomo Community Services District Waterline Intertie Project, May 2006.
- Central Coast Regional Water Quality Control Board, 2006. Phase Four: Project Analyses, Final Preliminary Project Report, Total Maximum Daily Loads for Nitrate and Ammonia in Santa Maria River and Oso Flaco Creek watersheds, Santa Barbara and San Luis Obispo Counties, California. December 5.
- U.S. Army Corps of Engineers. 2001. Memorandum: Supreme Court Ruling Concerning CWA Jurisdiction over Isolated Waters. January 19, 2001. Washington, D.C.
- U.S. Fish and Wildlife Service (USFWS). 2005. *Revised guidance on site assessments and field surveys for the California red-legged frog*. U.S. Fish and Wildlife Service, Portland, Oregon. 26.

## Appendix C: Projected Project Schedule Detail



## Appendix D: Opinion of Probable Cost



Opinion of Probable Cost - Construction

**Design and Construction Budget**

Seawater Desalination Facility  
Annual Production = 6300 AFY

Description	Quantity	Units	Unit Cost	Subtotal
<b>Professional Services (Design/Construction Management)</b>				
<b>Design Phase</b>				
Plans, Specifications, and Estimates (5% of Subtotal)	1	LS	\$3,090,000	\$3,090,000
Permit Applications and Coordination	1	LS	\$780,000	\$780,000
<b>Subtotal</b>				<b>\$3,870,000</b>
<b>Construction</b>				
<b>Construction Phase Professional Engineering Services</b>				
Construction Management (5% of Subtotal)	1	LS	\$3,090,000	\$3,090,000
Geotechnical Engineering/Materials Testing (3% of Subtotal)	1	LS	\$1,850,000	\$1,850,000
Environmental Mitigation and Monitoring (2% of Subtotal)	1	LS	\$1,240,000	\$1,240,000
<b>Subtotal</b>				<b>\$6,180,000</b>
<b>Intake/Discharge/Product</b>				
Mobilization (5% of subtotal)	1	LS	\$208,500	\$210,000
0.9 MGD Intake Wells	20	EA	\$175,000	\$3,500,000
36" Raw Water Pipeline	3	MI	\$1,200,000	\$3,600,000
24" Discharge Pipeline	3	MI	\$1,000,000	\$3,000,000
24" Product Pipeline	1.5	MI	\$1,000,000	\$1,500,000
0.9 MGD Subsurface Discharge Wells	10	EA	\$100,000	\$1,000,000
Electrical (10% of subtotal)	1	LS	\$347,500	\$350,000
Controls and Instrumentation (10% of subtotal)	1	LS	\$347,500	\$350,000
PG&E Service and Fees	1	LS	\$50,000	\$50,000
<b>Subtotal</b>				<b>\$13,560,000</b>
<b>Treatment Plant</b>				
Membrane filtration plant construction cost @ \$1.50/gpd	13	MGD	\$1,500,000	\$19,500,000
SWRO plant construction cost @ \$5/gpd	5.6	MGD	\$5,000,000	\$28,000,000
Convert District Wells to Chloramination	1	LS	\$700,000	\$700,000
<b>Subtotal</b>				<b>\$48,200,000</b>
<b>Construction Subtotal (Rounded to nearest \$100,000)</b>				<b>\$68,000,000</b>
<b>TOTAL Design and Construction (Rounded to nearest \$100,000)</b>				<b>\$71,900,000</b>

Opinion of Probable Cost - Phased Construction

**Design and Construction Budget**

Seawater Desalination Facility  
Annual Production = 6300 AFY

Description	Quantity	Units	Unit Cost	Subtotal	Phase 1	Phase 2
<b>Professional Services (Design/Construction Management)</b>						
<b>Design Phase</b>						
Plans, Specifications, and Estimates (5% of Subtotal)	1	LS	\$3,087,675	\$3,087,675	\$3,088,000	\$0
Permit Applications and Coordination	1	LS	\$780,800	\$780,800	\$781,000	\$0
<b>Subtotal</b>				<b>\$3,868,475</b>	<b>\$3,869,000</b>	<b>\$0</b>
<b>Construction</b>						
<b>Construction Phase Professional Engineering Services</b>						
Construction Management (5% of Subtotal)	1	LS	\$3,087,675	\$3,087,675	\$2,779,000	\$309,000
Geotechnical Engineering/Materials Testing (3% of Subtotal)	1	LS	\$1,852,605	\$1,852,605	\$1,853,000	\$0
Environmental Mitigation and Monitoring (2% of Subtotal)	1	LS	\$1,235,070	\$1,235,070	\$1,235,000	\$0
<b>Subtotal</b>				<b>\$6,175,350</b>	<b>\$5,867,000</b>	<b>\$309,000</b>
<b>Intake/Discharge/Product</b>						
Mobilization (5% of subtotal)	1	LS	\$208,500	\$208,500	\$209,000	\$0
0.9 MGD Intake Wells	20	EA	\$175,000	\$3,500,000	\$3,500,000	\$0
36" Raw Water Pipeline	3	MI	\$1,200,000	\$3,600,000	\$3,600,000	\$0
24" Discharge Pipeline	3	MI	\$1,000,000	\$3,000,000	\$3,000,000	\$0
24" Product Pipeline	1.5	MI	\$1,000,000	\$1,500,000	\$1,500,000	\$0
0.9 MGD Subsurface Discharge Wells	10	EA	\$100,000	\$1,000,000	\$1,000,000	\$0
Electrical (10% of subtotal)	1	LS	\$347,500	\$347,500	\$348,000	\$0
Controls and Instrumentation (10% of subtotal)	1	LS	\$347,500	\$347,500	\$348,000	\$0
PG&E Service and Fees	1	LS	\$50,000	\$50,000	\$50,000	\$0
<b>Subtotal</b>				<b>\$13,553,500</b>	<b>\$13,555,000</b>	<b>\$0</b>
<b>Treatment Plant</b>						
Membrane filtration plant construction cost @ \$1.50/gpd	13	MGD	\$1,500,000	\$19,500,000	\$15,600,000	\$3,900,000
SWRO plant construction cost @ \$5/gpd	5.6	MGD	\$5,000,000	\$28,000,000	\$22,400,000	\$5,600,000
Convert District Wells to Chloramination	1	LS	\$700,000	\$700,000	\$700,000	\$0
<b>Subtotal</b>				<b>\$48,200,000</b>	<b>\$38,700,000</b>	<b>\$9,500,000</b>
<b>Construction Subtotal (Rounded to nearest \$100,000)</b>				<b>\$68,000,000</b>	<b>\$58,200,000</b>	<b>\$9,900,000</b>
<b>TOTAL Design and Construction (Rounded to nearest \$100,000)</b>				<b>\$71,900,000</b>	<b>\$62,100,000</b>	<b>\$9,900,000</b>

# Evaluation of Supplemental Water Alternatives

## Technical Memorandum No. 3 Implementation of Water Supply from CCWA/State Water Pipeline

---

### Nipomo Community Services District

President	Michael Winn
Vice President	Larry Vierheilig
Director	Cliff Trotter
Director	Ed Eby
Director	Jim Harrison
General Manager	Bruce Buel
District Engineer	Peter Sevcik, PE

### Boyle Engineering Corporation

Project Manager	Mike Nunley, PE
Project Engineer	Malcolm McEwen, PE

19996.32  
November 30, 2007



**BOYLE**

1194 Pacific Street, Suite #204

San Luis Obispo, CA 93401

---

# Table of Contents

---

1.0 Introduction.....	1
Objective .....	1
Scope of Work.....	1
Prior Studies .....	1
The Limits of Information.....	3
2.0 Background.....	4
The State Water Project and the Central Coast Water Authority.....	4
State Water Allocations – Drought Buffers, Table A, Suspended Allocations, and Delivery Reliability .....	4
Table 1. Water Allocation, Drought Buffers, and Table A Amounts .....	5
Capacity Restrictions – Treatment at Polonio Pass and Pipeline Capacity to Nipomo .....	5
Polonio Pass Treatment Plant .....	5
Coastal Branch Phase 2.....	6
Table 2. Excess Conveyance Capacity .....	6
3.0 Framework for an Agreement.....	8
Legal Constraints .....	8
SWP/CCWA Stakeholders.....	8
Table 3. Stakeholder Issues.....	8
Possible Allocation of Additional Water and Costs for “Buy-In” .....	8
Table 4. Possible Allocation of Additional Water and Costs .....	9
Probable Costs and Their Impact on Proposed Allocation .....	9
Table 5. Estimated Costs in Agreement – Cost of Water at the Point of Delivery .....	10
Table 6. Estimated Costs of Parallel Pipeline.....	11
4.0 Facilities Needed.....	12

Cost of Improvements for the Connection (“Present Demand Only”) .....	12
Cost of Improvements to Integrate the Connection into the Master Plan (including Future Demand Considerations) .....	12
Allocation of Connection Costs between Existing and Future Users .....	13
5.0 Range of Costs .....	14
6.0 Implementation Schedule.....	15
Table 7. Implementation Schedule .....	15
Figure 1. Implementation Schedule – Short Time Estimate .....	15
7.0 Conclusions.....	16
Appendices.....	17
Appendix A Cost of State Water for City of Pismo Beach	
Appendix B Connection to State Water Project at Mehlschau Road – Opinion of Probable Cost	
Appendix C Santa Maria & Nipomo CSD State Water Project Costs Financial Summary (1961-2035) Prepared by Sierra Water Group, Inc. 8/25/2007	

# 1.0 Introduction

As directed by the Board of Directors of Nipomo Community Services District (NCSD), Boyle has prepared the following Technical Memorandum to assist the District in acquiring supplemental water from the Coastal Branch of the State Water Project (SWP). The Coastal Branch of the SWP consists of water conveyance facilities built by the California Department of Water Resources (DWR) and regional distribution and treatment facilities constructed by the Central Coast Water Authority (CCWA). The CCWA is responsible for operating and maintaining the Polonio Pass Water Treatment Plant and all of the downstream Coastal Branch facilities.

Negotiation with various stakeholders (including the San Luis Obispo Flood Control and Water Conservation District, State Water “subcontractors” in San Luis Obispo County, CCWA, and individual member agencies of CCWA) is ongoing. Therefore, this Memorandum does not present a detailed cost opinion or implementation strategy for this project.

## Objective

The objective of this Memorandum is to present an “interim report” regarding these negotiations and to identify facilities required for delivering this water. It is intended to provide the Board of Directors with sufficient information to decide whether to continue negotiations or to initiate implementation of the Waterline Intertie Project as a “short term” water supply.

## Scope of Work

This memo presents:

- a brief summary of pertinent background information,
- a description of a potential framework for an agreement to gain access to this water source,
- a description of the facilities needed to implement this project, and
- a summary of the ranges of costs which may be expected.

## Prior Studies

Boyle has completed two previous Technical Memoranda related to this work:

### TM 1 – Constraints Analysis

Boyle examined the feasibility and costs of alternatives to the Nipomo Waterline Intertie Project. Conclusions are listed below:

- Using Santa Maria groundwater was found to be infeasible because this alternative would likely affect the flow of water between Santa Maria Valley and the Nipomo Mesa Management Area, and would likely be prevented as a result of the adjudication.
- Extending the Nacimiento Water Project was found to be infeasible because the project was already out to bid, and as designed would not deliver the District’s desired 3,000 AFY.
- Drawing agricultural drainage from Oso Flaco is not considered to be a feasible supplemental water alternative due to the poor water quality of the water, inadequate quantity, likelihood of requiring approval from parties in Santa Maria Valley adjudication, and lack of support expected from drinking water regulators.
- Groundwater recharge with treated wastewater will not increase the water supply available to the District, but may assist with managing groundwater depressions and disposing of treated effluent.
- Seawater desalination is expected to take many years for implementation, would be an expensive water supply, and would require many years of studies and negotiation with resource agencies, but would represent the most reliable water supply available to the District.
- Direct purchase of 3,000 AFY or 6,300 AFY of State Water from the SWP pipeline did not appear to be feasible, due to institutional and legal constraints including the likelihood of paying a significant “buy-in” cost as repayment for past expenditures by participating State Water customers.

#### TM 2 - Evaluation of Desalination as a Source of Supplemental Water

Boyle provided the Nipomo Community Services District (NCSD) with a general plan to implement a seawater or brackish water desalination plant capable of delivering at least 6,300 acre-feet per year of desalted water. The report identified several key preliminary studies which will be needed in order to build and operate a desalination facility. The report found that implementation of a desalination plant may require approximately \$79 million, with additional costs for distribution system improvements. The implementation period may take over 8 years.

Significant challenges must be overcome to implement this project, as discussed in Technical Memoranda 2 and 3. Issues include the intake design, brine discharge location, and permitting constraints. Because of lack of information about the hydrogeologic characteristics of the areas proposed for subsurface intakes and discharges, it is unknown whether these structures will be feasible. In addition, there may be considerable pressure from regulatory agencies to form a regional partnership with South SLO County agencies

(City of Arroyo Grande, City of Grover Beach, and Oceano Community Services District) in lieu of developing two (2) desalination projects approximately 6-7 miles apart.

Prior to completing these draft memoranda, Boyle evaluated the cost for a waterline connection to the City of Santa Maria. Three alignments were examined with capital costs ranging from \$24 million to \$27 million and annual costs ranging from \$300,000 to \$320,000. Construction of the river crossing was expected to take 4 to 8 months and construction of the Nipomo-side transmission pipeline would take 2 to 6 months. Additional time would be needed for preliminary studies, design, permitting, bidding, and contracting, but the project could be implemented within the next two (2) to three (3) years.

## The Limits of Information

The values contained in this memorandum are projections of future transactions. The reliability of these values may be categorized as follows:

- Very reliable values include (1) projections of construction costs for installation of common infrastructure items such as pipelines, and (2) projections of recurring costs that will be paid to CCWA and DWR for operation and maintenance of the system.
- Moderately reliable values include (1) projections of construction costs for installation of uncommon infrastructure items such as highway crossings, pressure-reducing stations, and chloramination facilities; and (2) projections of construction costs for large components based on construction costs that obtained several (or many) years ago (such as the water treatment plant expansion.)
- Unreliable values include projections based on costs which are negotiable, such as buy-in costs.



# 2.0 Background

## The State Water Project and the Central Coast Water Authority

The State Water Project (SWP) is a system of dams, reservoirs, power and pumping plants, canals, and aqueducts that conveys water from Lake Oroville to Southern California. The “Coastal Branch” of the SWP consists of water conveyance facilities built by the California Department of Water Resources (DWR) and regional distribution and treatment facilities constructed by the Central Coast Water Authority (CCWA).

Coastal Branch Phase I was completed in 1968. Phase II of the Coastal Branch was completed in 1997 and brings SWP water to San Luis Obispo and Santa Barbara Counties. Key facilities include the Polonio Pass Water Treatment Plant (PPWTP), approximately 143 miles of pipeline, and associated pumping plants and storage tanks. Individual components of the Coastal Branch were built by either the DWR or CCWA. However, CCWA is responsible for operating and maintaining the Polonio Pass Water Treatment Plant and all of the downstream Coastal Branch facilities.

## State Water Allocations – Drought Buffers, Table A, Suspended Allocations, and Delivery Reliability

The State Water Project delivers water to each of its contractors based on that contractor’s “Table A Amount.” In approximately 3 out of 10 years the SWP delivers the full amount. In years when deliveries are reduced, each contractor’s delivery amount is reduced by the same fraction. It has been estimated that on average the SWP will deliver approximately 75% of its Table A Amounts (California Department of Water Resources, Bay-Delta Office, The State Water Project Delivery Reliability Report, 2005).

To increase the reliability of delivery, some contractors increased their Table A Amounts above the amounts they planned to use. These excess Table A Amounts are typically considered “drought buffers.”

According to the CCWA 2005 Urban Water Management Plan:

*Originally, SBCFC&WCD requested 57,700 acre-feet of water annually. In 1980, Santa Barbara County water purveyors requested and agreed to pay for 45,486 acre-feet and SBCFC&WCD, with the concurrence of DWR, suspended the remaining 12,214 acre feet. CCWA is actively pursuing a possible repurchase of 12,214 acre-feet of SBCFC&WCD Table A Amount that was suspended by request in 1981.*

*In 1994, Santa Barbara County water purveyors, now part of CCWA, agreed to take 39,078 acre-feet with an additional 3,908 acre-feet of drought buffer. Goleta Water District took an additional 2,500 acre-feet of drought buffer to further firm up its supply.*

*SLOCFC&WCD originally requested 25,000 acre-feet annually. In 1991, it decided, however, to participate in the treatment and conveyance facilities for 4,830 acre-feet only. ...*

*SLOCFC&WCD has 25,000 acre-feet of Table A available but can only take delivery of 4,830 acre-feet in any given year, and SBCFC&WCD has 45,486 acre-feet available, but can only take delivery of 42,908 in any given year. ... As a result, CCWA project participants typically have at least 5,000 acre-feet in each normal year to carryover into the next year.*

SLO County’s excess allocation can be used: to ensure achievement of full allocation in years of low delivery from State (<100%); for groundwater banking in and out of County (currently evaluating in-County); turnback pools (sell to the state or other contractors); permanent sale; yearly/multi-year sale; or used in County after expansion of facilities and/or contract negotiation. ([www.slocountywater.org](http://www.slocountywater.org))

These quantities are summarized below:

**Table 1. Water Allocation, Drought Buffers, and Table A Amounts**

<b>Turnout</b>	<b>Allocation (afy)</b>	<b>Drought Buffer (afy)</b>	<b>Total Table A Amount (afy)</b>
Chorro Valley	2,438	3,315	5,753
Lopez	2,392	302	2,694
SLO County Excess Allocation (1)			16,553
<b>SLO County Subtotal</b>	<b>4,830</b>	<b>3,617</b>	<b>25,000</b>
Santa Maria Valley Turnouts	17,250	1,725	18,975
Other SB County Turnouts	21,828	2,183	24,011
Goleta Water District Drought Buffer		2,500	2,500
<b>Santa Barbara County Subtotal</b>	<b>39,078</b>	<b>6,408</b>	<b>45,486</b>
SWP/CCWA Total	43,908	10,025	67,986

## **Capacity Restrictions – Treatment at Polonio Pass and Pipeline Capacity to Nipomo**

The annual conveyance capacities of the various portions of the existing Phase II Coastal Branch of the State Water Project were designed to deliver the amounts discussed below. These reported capacities take into account the fact that the pipeline and treatment plant are operated 11 out of 12 months each year.

### **Polonio Pass Treatment Plant**

The Polonio Pass Treatment Plant (PPTP) is reported to have a treatment capacity of 50,758 acre-feet per year (CCWA 2007/08 Budget.) The CCWA has allocated this treatment capacity to deliver the full

Table A amounts to Santa Barbara County participants (45,486 afy) and the non-drought buffer allocation amounts to San Luis Obispo County participants (4,830 afy). [45,486 + 4,830 = 50,316 afy] Thus, treatment capacity is almost fully allocated.

Depending on the changing month-by-month and year-by-year demands of the various participants, it may be possible to treat additional water for Nipomo CSD without making capital improvements to the PPTP. However, without implementing an in-depth engineering and operational analysis of the PPTP, it is not possible to quantify the amount of “excess” capacity in this facility.

### Coastal Branch Phase 2

In 2005 Penfield & Smith produced a Pipeline System Modeling report for CCWA. Results of this study are summarized below. The committed capacities listed are sufficient to provide all Santa Barbara County participants with their Table A Amounts plus drought buffer, and all San Luis Obispo County participants with their Table A Amounts - without drought buffer. The existing capacities listed refer to the existing physical restrictions on conveyance. The excess capacity is the difference between the committed and existing capacities.

**Table 2. Excess Conveyance Capacity**

Component	Committed Capacity	Existing Capacity	Excess Capacity
Pipeline from Devils Den Pumping Plant to Polonio Pass	50,316 afy	74,125 afy (1)	23,809 afy
Pipeline from PPWTP to Lopez Lake	47,816 afy	56,916 afy (2a) to 53,416 afy (2b)	9,100 afy (2a) to 5,600 afy (2b)
Pipeline from Lopez to Santa Maria Valley (Tank 5)	42,986 afy	42,986 afy (2a) to 48,586 afy (2b)	0 afy (2a) to 5,600 afy (2b)
Pipeline south of Tank 5	24,011 afy	24,011 afy	0 afy

Notes:

(1) Reported in SLOCFCWCD Paso Robles Groundwater Subbasin Water Banking Feasibility Study, Draft, August 2007.

(2) Pennfield & Smith, July 2005 – C factor = 150 above Tank 5; C factor = 135 below Tank 5.

(2a) All excess (9,100 afy) taken at Lopez turnout

(2b) All excess (5,600 afy) taken in Santa Maria Valley

The amount of water in excess of the CCWA-committed delivery amount that could be delivered to the Santa Maria Valley turnouts depends on the amount of water in excess of the CCWA-committed delivery amount delivered to the Lopez turnout (or to a new Nipomo turnout), as shown below.

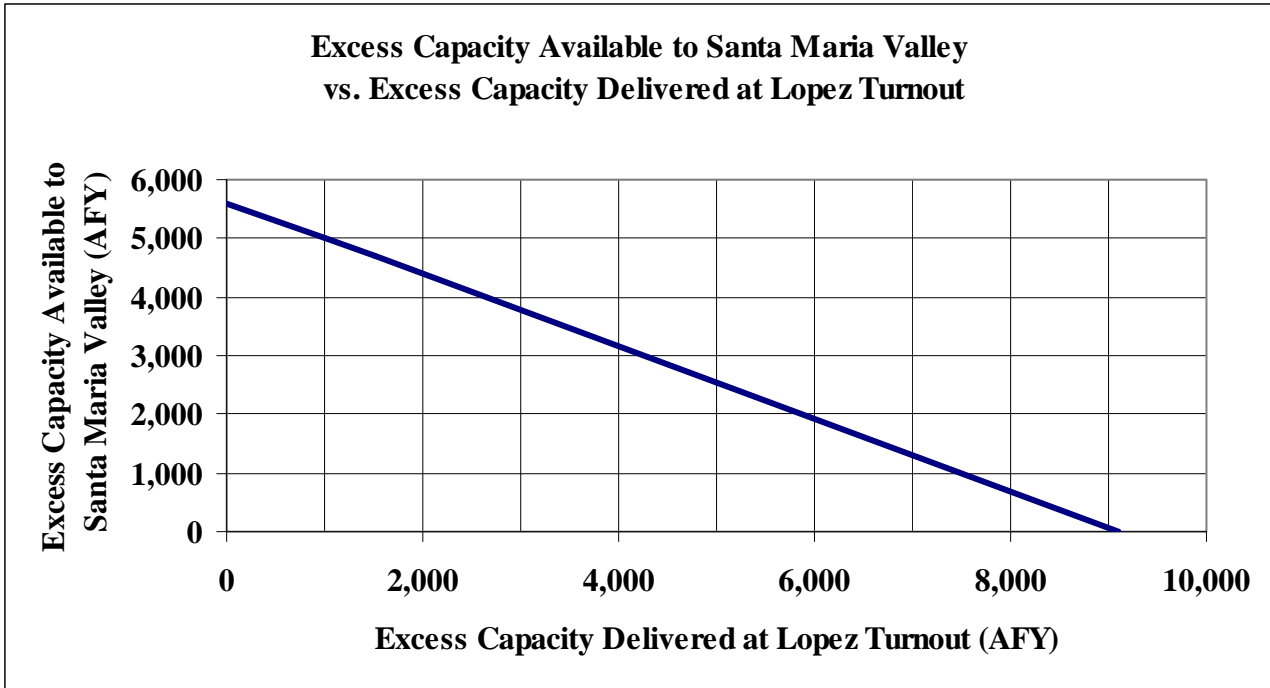

**Figure 1 Santa Maria Valley Excess Delivery Capacity**

# 3.0 Framework for an Agreement

## Legal Constraints

As discussed in Technical Memorandum 1, Nipomo residents opposed State Water delivery in two separate ballots. Therefore, District legal counsel has recommended the District sponsor a new ballot to allow voters to reconsider their previous decisions. After a general framework is developed through negotiation with the stakeholders listed below, it is assumed the District will be able to present project costs in sufficient detail for the voters.

## SWP/CCWA Stakeholders

The following stakeholders to a proposed agreement have the following motivations and concerns.

**Table 3. Stakeholder Issues**

Entity	Potential Motivations	Concerns
San Luis Obispo County taxpayers who do not now receive State Water	Taxes could be reduced by amount paid by Nipomo for use of excess allocation	
San Luis Obispo County Flood Control and Water Conservation District	Obtain Revenue for unused Table A amounts	May lose the right to 16,000 afy if not used.
Other SLO County SWP subcontractors	Reduce the fixed cost of their Table A allocation Additional Water desired by some users	
City of Santa Maria	Wants more water and payback for pipeline cost	Proposal should be comparable or more attractive than existing MOU with District
Montecito Water District	Wants more water and payback for pipeline cost	
All SWP Subcontractors	Want more water and/or payback for pipeline cost	
CCWA	Ensure reliable State Water deliveries to member agencies Find opportunities to improve reliability of State Water for member agencies	

## Possible Allocation of Additional Water and Costs for “Buy-In”

Terms and conditions will be defined through negotiation with these agencies, but the following outline presents one possible scenario. The table represents a possible basis for an agreement that may result in SWP water for Nipomo CSD. Water is reported as “Table A Amounts”, wet water (i.e. Table A Amounts actually delivered), and drought buffer (i.e., used to increase reliability of delivery, but never actually delivered.)

**Table 4. Possible Allocation of Additional Water and Costs**

Entity	Water	Cost or Income
NCSD	Gets 2,500 to 3,000 afy “wet water” Table A amount from SLO County.	Pays \$ for buy-in costs, including possible Polonio Pass WTP expansion (if required) Pays \$ for right to State Water Project water.
Lopez turnout participants	Get 1,000 afy “wet water” Table A amount at Lopez turnout.	
Other SLO County SWP Subcontractors		Reduced cost for Table A amounts. (a)
SLO County taxpayers		Reduced cost for “holding” excess SWP allocation.
City of Santa Maria	Gets 4,500 to 5,000 afy Table A amount from SLO County: <ul style="list-style-type: none"> <li>• 1,500 to 2,000 afy as “wet water”.</li> <li>• 3,000 afy as drought buffer.</li> </ul>	Pays \$ for Polonio Pass WTP expansion (if required) Reimbursal for past expenditures from buy-in costs paid by NCSD
Montecito Water District	Gets 500 afy “wet water” from SLO County.	Reimbursal for past expenditures from buy-in costs paid by NCSD
CCWA	Needs to treat and transport additional 5,500 to 6,500 afy.	Reimbursal for past expenditures from buy-in costs paid by NCSD

Notes:

(a) San Luis Obispo County taxpayers have been paying approximately \$1 million per year to “hold” the 20,130 afy in excess allocation (SLO Telegram-Tribune, 4/30/1996). If SLO County were to release 10,000 afy of their Table A amounts (a portion to be used as drought buffer, and a portion actually delivered), then the tax could be cut by almost half.

**Probable Costs and Their Impact on Proposed Allocation**

The following table summarizes a range of costs for NCSD to obtain water from the State Water Project. These estimated costs do not include costs to the District for local connection, conveyance, and storage facilities. Those costs are discussed in a later section.

Purchase of water will include two cost components: (1) annual costs for CCWA operation, maintenance, and continuing debt service; and (2) buy-in cost for past capital improvement payments made by the seller. The former is routinely calculated while the latter is more difficult to determine. In a recent sale of 400 AFY from Carpinteria Valley Water District, annual costs were \$1,500/af and the buy-in costs were \$5,000/afy of capacity (Carpinteria Valley Water District, Board of Directors Meeting, April 26, 2006.) However, a buy-in cost of \$13,000 per afy of capacity was said to be “reasonable” at a recent meeting of stakeholders (11/21/2007.)

Note that the following estimated costs are only for obtaining water from the pipeline – at the pipeline. There will be additional costs for the construction and operation of District facilities required to

implement the interconnection to the District’s distribution system. These costs are discussed in Section 4.

**Table 5. Estimated Costs in Agreement – Cost of Water at the Point of Delivery**

<b>One-Time Costs</b>	<b>Low Estimate</b>	<b>Medium Estimate</b>	<b>High Estimate</b>
Buy-in Cost to NCSD for 3,000 afy for existing conveyance and treatment	\$3.6 M (a) (3,000 afy @ \$1,180/afy)	\$15 M (b) (3,000 afy @ \$5,000/afy)	\$39 M (c) (3,000 afy @ \$13,000/afy)
Buy-in Cost to NCSD for 3,000 afy for Polonio Pass Expansion	Zero (assumes excess capacity exists)	\$12.3 M (3,000 afy @ \$4,100/afy) (50% of original costs)	\$24.6 M (3,000 afy @ \$8,200/afy) (original CCWA costs)
<b>Total One-Time Costs</b>	<b>\$3.6 M</b>	<b>\$27.3 M</b>	<b>\$63.6 M</b>

<b>Annual Costs</b>	<b>Low Estimate</b>	<b>Medium Estimate</b>	<b>High Estimate (s)</b>
Annualized One-Time Costs (20 years @ 6%)	\$0.3 M	\$2.4 M	\$5.5 M
Annual fixed cost paid to CCWA, DWR, and SLOCFCWCD by NCSD	\$2.8 M (3,000 af @ \$930/af) (current price to Pismo Beach)	\$3.3 M (assumes 20% increase)	\$3.3 M (assumes 20% increase)
Annual variable cost paid to CCWA, DWR, and SLOCFCWCD by NCSD	\$0.6 M (3,000 af @ \$185/af) (current price to Pismo Beach)	\$0.7 M (assumes 20% increase)	\$0.7 M (assumes 20% increase)
<b>Total Annual Costs</b>	<b>\$3.7 M</b>	<b>\$6.4 M</b>	<b>\$9.5 M</b>

<b>Cost of Water</b>	<b>Low Estimate</b>	<b>Medium Estimate</b>	<b>High Estimate (s)</b>
Total Cost per acre-foot delivered (based on long-term average delivery of 75% of 3,000 afy = 2,250 afy)	\$1,600 / af	\$2,800 / af	\$4,200 / af

Notes:

(a) Unescalated cost based on \$1,180/afy of capacity as paid by SLO County SWP contractors prior to water deliveries.

(b) Carpinteria sale to PXP, April 26, 2006.

(c) Estimated net present value of past capital costs to Santa Maria. See Appendix C.

It has been reported that Santa Barbara County is considering building another pipeline within the Coastal Branch right-of way for transporting 11,200 afy of their suspended allocation. For purposes of comparison the probable costs of that project are summarized below.

**Table 6. Estimated Costs of Parallel Pipeline**

<b>Cost Assumptions</b>	<b>Low Estimate</b>	<b>High Estimate</b>
Buy-back cost for Santa Barbara County's 11,200 afy Suspended Table A amount	\$15 M (11,200 afy @ \$1,340/afy)	\$17 M (11,200 afy @ \$1,520/afy)
Design and Construction cost to Santa Barbara County for building a pipeline parallel to the existing SWP/CCWA pipeline.	\$560 M (143 miles @ \$3.9 M/mile) (Nacimiento Project bids)	\$1.04 B (143 miles @ \$7.3 M/mile) (SWP costs adjusted for inflation)
Design and Construction Cost to Santa Barbara County for 11,200 afy treatment plant	\$92 M (11,200 afy @ \$8,200/afy)	\$92 M (11,200 afy @ \$8,200/afy)
<b>Total Cost</b>	<b>\$667 M</b>	<b>\$1.2 B</b>



## 4.0 Facilities Needed

Assuming the District is able to connect to the State Water Project at Mehlschau Road, a number of improvements will be needed to implement this connection.

A preliminary hydraulic analysis of the SWP show the hydraulic grade line (HGL) at Mehlschau Road to be from 794 to 910 ft. above mean sea level (MSL). Ground surface elevation at the intersection with Mehlschau Road is approximately 350 ft MSL, giving pipeline pressures of between 193 and 244 psi (pounds per square inch). Sufficient pressure would exist to move the released water up to the Quad Tanks (at 540 ft MSL). The preferred alignment for this pipeline is depicted in Appendix B.

In addition, it is anticipated the District will be required to take constant flow deliveries from the CCWA facilities. This will require the District construct equalization storage to address differences between short-term deliveries and fluctuating demands.

### Cost of Improvements for the Connection (“Present Demand Only”)

If the purpose is to acquire a connection to the SWP for meeting present demand only, then this could be accomplished by installing a pressure-reducing valve system and approximately 2 miles of 12-inch water main, and by converting to chloramination at each well head. Our opinion of probable cost for these improvements would be \$3.8 million (including contingencies and engineering, no property acquisition), as described in Appendix B.

The Water Master Plan cites the need for approximately 1.0 million gallons of operational storage to accommodate this supply. Assuming an additional storage tank is constructed either near the turnout or at the Quad Tanks site, the cost for this storage tank would be approximately \$1.5M (including engineering and contingency, no property acquisition).

Therefore, the cost for the pressure reducing station, 12” pipeline, and 1.0 MG storage tank would be approximately \$5.3M. This one-time cost could be amortized over 20 years at 6% with annual payments of \$460,000. Adding \$27,000 for additional O&M, and assuming on average 2,250 acre-feet are delivered per year, the cost of these local facilities would be approximately \$225 per acre-foot delivered.

### Cost of Improvements to Integrate the Connection into the Master Plan (including Future Demand Considerations)

The Water and Sewer Master Plan Update (Administrative Draft) for the District recently prepared by Cannon Associates makes provisions for connection to the State Water Project. This Master Plan Update lists a number of improvements (“Priority 1 – Backbone Improvements to Accommodate New Supply at Thompson and Mehlschau”) needed to implement the connection: a pressure reducing station, 13,600 feet of new 14” and 24” diameter water main, conversion to chloramination at each well head,

and a 1 million gallon storage tank. The cost projection for these improvements was \$5.5 million including contingencies and engineering.

In addition, approximately 15,700 feet of 12”, 16” and 18” diameter water main will be needed to link the new east side supply and storage improvements to the western portion of the District’s distribution network via the proposed Willow Road extension. The cost of these improvements was projected to be approximately \$3.25 million.

The total cost to fully integrate the new water source into the existing and future water distribution system would therefore be approximately \$8.8 million. This one-time cost could be amortized over 20 years at 6% with annual payments of \$770,000. Adding \$27,000 for additional O&M, and assuming on average 2,250 acre-feet are delivered per year, the cost of these local facilities would be approximately \$350 per acre-foot delivered.

## **Allocation of Connection Costs between Existing and Future Users**

The discussion above may form the basis for allocating capital costs for the “Master Plan” connection between existing and future users. \$5.3 million could be allocated to existing users, since that is the “minimum” project required to deliver State Water, while the remaining \$3.5 million can be allocated to future users.

## 5.0 Range of Costs

A range of costs are presented below, based on various assumptions about whether the low cost or high cost assumptions are valid for a particular component. These costs are based on the assumption that 3,000 acre-feet are allocated but on average only 2,250 acre-feet are delivered per year, and that the one-time costs for “buy-in” and distribution system improvements are amortized at 6% over 20 years. This allows a “per acre-foot” cost comparison with the Waterline Intertie Project (at approximately \$1720-2120 per acre-foot based on the Memorandum of Understanding and the Preliminary Engineering Memorandum, *ibid.*)

The lowest cost that can be expected would apply if there are minimal buy-in costs, the Polonio Pass treatment plant does not require expansion, and the District implements the “present demand only” connection improvements (12” pipeline, pressure reducing station, and new 1.0 MG storage tank). After considering that the State Water Project can be relied upon for 75% of Table A deliveries on a long-term basis, cost would be \$1,850 per acre-foot without purchase of an additional “drought buffer”.

If the buy-in costs are \$15 million and the cost of expanding the Polonio Pass WTP is \$12.3 million, and the District implements the “present demand only” connection improvements, then the per acre-foot cost of delivered water would be \$3,025/af. If the “master plan” connection improvements are implemented, the cost rises to \$3,150 per acre-foot delivered.

The maximum expected cost would be \$4,550 per acre-foot delivered. This cost would apply if buy-in costs are \$39 million, the Polonio Pass treatment plant requires an expansion costing \$24.6 million, and the District implements the “master plan” connection improvements.

# 6.0 Implementation Schedule

The following implementation schedule assumes the various governmental organizations will approve the project, after having had sufficient time to determine the benefit involved. The following approach can lead to project implementation in as little as 4 years, or as long as 7 years, as noted below.

**Table 7. Implementation Schedule**

Action	Short Time	Long Time
Determine Capacities of Polonio Pass Water Treatment Plant and Coastal Branch Pipeline	6 months	12 months
Gain approval from all agencies that will be party to the agreement: - SLO County Flood Control and Water Conservation District (i.e., SLO County Board of Supervisors) - City of Santa Maria - Montecito Water District - Central Coast Water Authority - California Department of Water Resources	9 months	18 months
Ballot Procedure for Nipomo CSD Customers	6 months	6 months
Amend Contracts with California Department of Water Resources	6 months	12 months
Preliminary Design	3 months	6 months
California Environmental Quality Act (CEQA) Process	6 months	12 months
Engineering, Final Design, Bidding and Contracting	3 months	6 months
Construction	9 months	12 months
<b>Total</b>	<b>4 years</b>	<b>7 years</b>

**Figure 1. Implementation Schedule – Short Time Estimate**

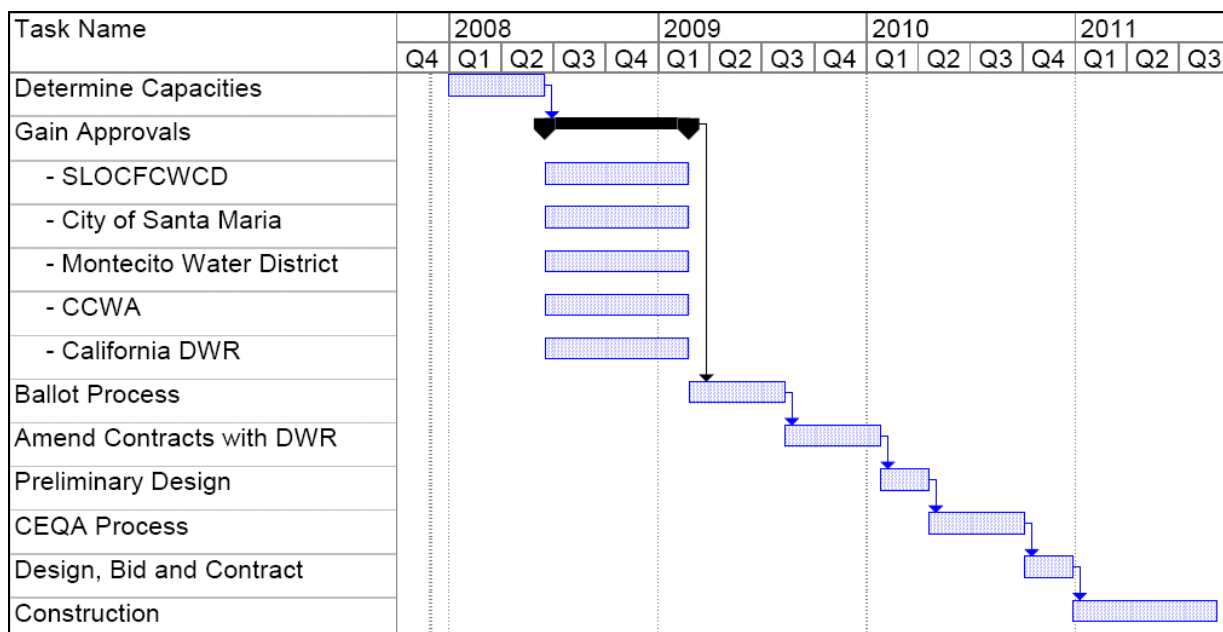

# 7.0 Conclusions

As discussed in this Technical Memorandum, capital and buy-in costs for connecting to the coastal Branch of the State Water Project at Mehlschau and Thompson could vary widely (from \$8.9 M minimum to over \$72 M). In addition, State Water is considered to have a long-term reliability of 75% (California Department of Water Resources, Bay-Delta Office, The State Water Project Delivery Reliability Report, 2005). Therefore, it appears the cost of connecting to the State Water Project may be similar in cost to the Waterline Intertie Project (or significantly more expensive) with lower reliability. The Waterline Intertie Project is considered more reliable because the City of Santa Maria can provide groundwater during State Water Project shortages or failures.

The “final” cost for connecting to CCWA facilities will require negotiation among the various stakeholders mentioned above. Therefore, if the District decides to continue with this process, we recommend the District conclude cost negotiations with these various agencies prior to beginning the CEQA process, ballot procedure, or subsequent tasks.

We also recommend that additional studies be undertaken to conclusively determine the capacity limits of the Polonio Pass Water Treatment Plant and the Coastal Branch pipeline.

# Appendices

# Appendix A Cost of State Water for City of Pismo Beach

---

## MEMORANDUM

---

TO: Bruce Buel  
Peter Sevcik, PE

November 8, 2007

FROM: Mike Nunley, PE

SUBJECT: Cost of State Water for City of Pismo Beach

I received some information from the San Luis Obispo County Public Works Department regarding the City of Pismo Beach's costs for State Water. The following is the approximate 2007 cost breakdown for delivery to the Lopez Distribution System, without including any Lopez system costs. Pismo Beach and other County participants paid DWR for initial costs when contracts were signed in 1992 and began receiving State Water in August of 1997.

Initial payment to DWR was approximately \$5,723,000 for the 4,830 acre-feet of the County's contracted allocation (approximately \$1184 per acre-foot).

### Cost per Acre-Foot for State Water

Component	DWR (1)	SLOFC	CCWA	\$/AF Cost
Capital	\$532		\$140	\$672
Fixed O&M	\$105		\$75	\$180
Variable	\$155		\$30	\$185
Administrative		\$78		\$78
<b>Totals</b>	<b>\$792</b>	<b>\$78</b>	<b>\$245</b>	<b>\$1,115</b>

(1) Estimate based on the basic contractors allocation before adjustments (under/overpayments) for prior years

Please let me know if you have questions or comments.



# **Appendix B      Connection to State Water Project at Mehlschau Road – Opinion of Probable Cost**

---

## MEMORANDUM

---

TO: Bruce Buel, General Manager, NCSD

FROM: Malcolm McEwen

SUBJECT: Connection to State Water Project at Mehlschau Road  
- Opinion of Probable Cost

November 8, 2007

As requested, Boyle has prepared an opinion of the probable cost of connecting to the State Water Project at Mehlschau Road.

Our preliminary hydraulic analysis of SWP show the hydraulic grade line (HGL) at Mehlschau Road to be from 794 to 910 ft. above mean sea level (MSL). Ground surface elevation at the intersection with Mehlschau Road is approximately 350 ft MSL, giving pipeline pressures of between 193 and 244 psi (pounds per square inch). With a 12-inch PVC pipe, sufficient pressure would exist to pass 1690 gpm up to the Quad Tanks (at 540 ft MSL). This flow rate is equivalent to 2500 acre-feet per year, delivered over 11 months.

The following planning-level opinion of probable cost assumed installation of a pressure-relief valve system, with connection to the SCADA system, a building to house the valve(s) and controls, and approximately 2 miles of 12-inch PVC installed in paved roads (@ \$200/ft). Our opinion of probable cost, including engineering costs and contingency, is summarized below.

Cost Component	Capital Cost	Annual Capital Cost*	Annual Operating Cost	Total Annual Cost
Installation - Connection and PRV	\$677,000	\$59,000		\$59,000
Installation - 12-inch Pipeline to Quad Tanks	2,060,000	180,000		180,000
Additional Maintenance (1% of Capital)			\$27,000	27,000
<b>Total</b>	<b>\$2,727,000</b>	<b>\$239,000</b>		<b>\$266,000</b>

\* 6% over 20 years

With an annual cost of \$266,000 for delivering 2500 afy, the cost per acre-foot would be approximately \$110/af, excluding any costs to CCWA, SLO County, or the SWP.



Enclosure: Attachment A – State Water Project Connection at Mehlschau Road

Copy to: M. Nunley

DWG: W:\Nipomo CSD (19996)\19996.32 (Alternative Water Supply)\CAD\Exhibits\EXHIBIT A - connect to coastal branch SWP.dwg  
 DATE: Nov 08, 2007 6:55am  
 XREFS:  
 IMAGES: quad map for coastal SWP Pipeline.TIF  
 USER: jfroelicher

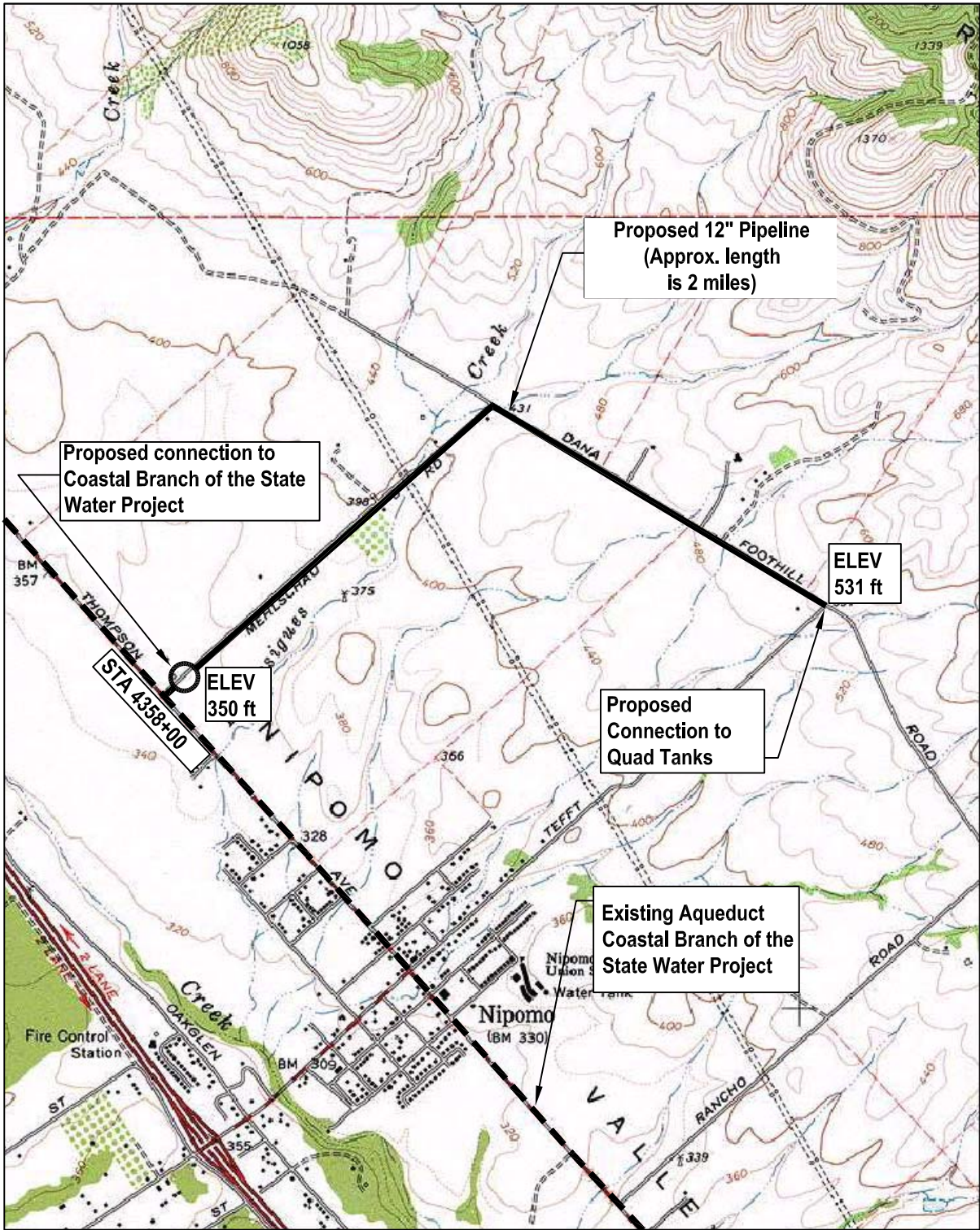

Proposed 12" Pipeline  
 (Approx. length  
 is 2 miles)

Proposed connection to  
 Coastal Branch of the State  
 Water Project

STA 4358+00  
 ELEV  
 350 ft

ELEV  
 531 ft

Proposed  
 Connection to  
 Quad Tanks

Existing Aqueduct  
 Coastal Branch of the  
 State Water Project

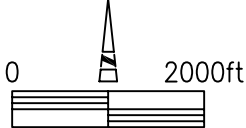

\*\*NOTE: MAP FROM NATIONAL GEOGRAPHIC TOPO

**BOYLE**  
 ENGINEERING CORPORATION  
 1194 Pacific St., Suite 204 Tel. 805-542-9840  
 San Luis Obispo, CA. 93401 Fax 805-542-9990  
 WWW.BOYLEENGINEERING.COM

PROPOSED CONNECTION TO THE COASTAL  
 BRANCH OF THE STATE WATER PROJECT AT STA  
 4358+00 (APPROXIMATELY)  
 IN NIPOMO, SAN LUIS OBISPO COUNTY

BEC  
 PROJECT NO.  
 19996.32

EXHIBIT  
**A**

Mehlschau Connection to SWP - Pipeline to Quad Tanks

Assumptions

Power cost	zero	HGL high enough - no pumping
Years	20	
Interest Rate	6%	

Cost Component	Capital Cost	Annual Capital Cost	Annual Operating Cost	Total annual Cost
Installation - Connection and PRV	\$ 667,000	\$ 59,000		\$ 59,000
Installation - 12-inch Pipeline to Quad Tanks	\$ 2,060,000	\$ 180,000		\$ 180,000
Additional Maintenance			\$ 27,000	\$ 27,000
<b>Total</b>	<b>\$ 2,727,000</b>	<b>\$ 239,000</b>		<b>\$ 266,000</b>

Water Delivered 2,500 afy

Cost per afy \$110 /afy

**Appendix C      Santa Maria & Nipomo CSD  
State Water Project Costs  
Financial Summary (1961-  
2035)  
Prepared by Sierra Water  
Group, Inc.  
8/25/2007**

**SANTA MARIA & NIPOMO CSD**

**State Water Project Costs (SLO & SB Counties)**

**Financial Summary (1961-2035)**

<b>Category</b>	<b>NPV Cost/AF 1961-2007</b>	<b>NPV Cost/AF 2008-2035</b>	<b>NPV Cost/AF Total</b>
SLO DWR Costs	\$4,446	\$4,082	\$8,527
SLO CCWA Costs	<u>\$923</u>	<u>\$1,128</u>	<u>\$2,051</u>
<b>SLO, Subtotal</b>	<b>\$5,368</b>	<b>\$5,210</b>	<b>\$10,578</b>
SB DWR Costs	\$11,795	\$10,373	\$22,169
SB CCWA Costs	<u>\$1,224</u>	<u>\$5,185</u>	<u>\$6,409</u>
<b>SB, Subtotal</b>	<b>\$13,019</b>	<b>\$15,558</b>	<b>\$28,577</b>
<b>Total</b>	<b>\$18,387</b>	<b>\$20,768</b>	<b>\$39,155</b>

Prepared By: Sierra Water Group, Inc.

August 25, 2007

**SAN LUIS OBISPO COUNTY**

**State Water Project - DWR Charges**

**Financial Summary (1961-2035)**

		100.0%	5.0%		25,000
<b>Year</b>	<b>SLO SWP Payments</b>	<b>SLO SWP Fixed</b>	<b>Factor</b>	<b>Adjusted Payments</b>	<b>Adjusted per AF</b>
1	1961	-	-	9.43	-
2	1962	-	-	8.99	-
3	1963	-	-	8.56	-
4	1964	\$6,696	\$6,696	8.15	\$54,570
5	1965	13,756	13,756	7.76	106,768
6	1966	26,524	26,524	7.39	196,065
7	1967	56,469	56,469	7.04	397,541
8	1968	115,960	115,960	6.70	777,483
9	1969	185,156	185,156	6.39	1,182,309
10	1970	200,150	200,150	6.08	1,217,194
11	1971	202,413	202,413	5.79	1,172,339
12	1972	209,057	209,057	5.52	1,153,162
13	1973	206,557	206,557	5.25	1,085,116
14	1974	208,545	208,545	5.00	1,043,390
15	1975	225,895	225,895	4.76	1,076,376
16	1976	228,976	228,976	4.54	1,039,102
17	1977	238,699	238,699	4.32	1,031,643
18	1978	245,331	245,331	4.12	1,009,816
19	1979	243,110	243,110	3.92	953,023
20	1980	282,254	282,254	3.73	1,053,783
21	1981	307,065	307,065	3.56	1,091,823
22	1982	328,215	328,215	3.39	1,111,452
23	1983	357,218	357,218	3.23	1,152,064
24	1984	409,530	409,530	3.07	1,257,881
25	1985	500,696	500,696	2.93	1,464,666
26	1986	536,751	536,751	2.79	1,495,368
27	1987	570,644	570,644	2.65	1,514,088
28	1988	673,071	673,071	2.53	1,700,817
29	1989	772,571	772,571	2.41	1,859,284
30	1990	933,367	933,367	2.29	2,139,294
31	1991	979,709	979,709	2.18	2,138,582
32	1992	1,118,807	1,118,807	2.08	2,325,919
33	1993	1,185,666	1,185,666	1.98	2,347,538
34	1994	1,335,974	1,335,974	1.89	2,519,178
35	1995	1,647,816	1,647,816	1.80	2,959,241
36	1996	2,592,043	2,592,043	1.71	4,433,273
37	1997	3,002,833	3,002,833	1.63	4,891,299
38	1998	3,256,282	3,256,282	1.55	5,051,562
39	1999	3,801,021	3,801,021	1.48	5,615,839
40	2000	3,796,090	3,796,090	1.41	5,341,480
41	2001	4,333,398	4,333,398	1.34	5,807,168
42	2002	4,057,625	4,057,625	1.28	5,178,672
43	2003	4,157,464	4,157,464	1.22	5,053,423
44	2004	5,489,168	5,489,168	1.16	6,354,398
45	2005	7,112,399	7,112,399	1.10	7,841,420

	Year	SLO SWP Payments	SLO SWP Fixed	Factor	Adjusted Payments	Adjusted per AF
46	2006	\$6,574,402	\$6,574,402	1.05	\$6,903,122	\$276.12
47	2007	7,044,971	7,044,971	1.00	7,044,971	281.80
48	2008	6,920,976	6,920,976	0.95	6,591,406	263.66
49	2009	6,902,252	6,902,252	0.91	6,260,546	250.42
50	2010	7,041,389	7,041,389	0.86	6,082,617	243.30
51	2011	7,040,017	7,040,017	0.82	5,791,839	231.67
52	2012	7,122,846	7,122,846	0.78	5,580,936	223.24
53	2013	7,100,760	7,100,760	0.75	5,298,696	211.95
54	2014	6,978,549	6,978,549	0.71	4,959,524	198.38
55	2015	7,008,567	7,008,567	0.68	4,743,674	189.75
56	2016	7,058,499	7,058,499	0.64	4,549,971	182.00
57	2017	6,944,803	6,944,803	0.61	4,263,507	170.54
58	2018	6,893,716	6,893,716	0.58	4,030,613	161.22
59	2019	7,009,412	7,009,412	0.56	3,903,103	156.12
60	2020	6,792,334	6,792,334	0.53	3,602,120	144.08
61	2021	6,814,203	6,814,203	0.51	3,441,636	137.67
62	2022	6,683,070	6,683,070	0.48	3,214,671	128.59
63	2023	6,718,658	6,718,658	0.46	3,077,895	123.12
64	2024	6,818,807	6,818,807	0.44	2,975,023	119.00
65	2025	6,698,081	6,698,081	0.42	2,783,191	111.33
66	2026	6,745,882	6,745,882	0.40	2,669,575	106.78
67	2027	6,668,526	6,668,526	0.38	2,513,297	100.53
68	2028	6,665,238	6,665,238	0.36	2,392,436	95.70
69	2029	6,617,756	6,617,756	0.34	2,262,279	90.49
70	2030	6,347,082	6,347,082	0.33	2,066,428	82.66
71	2031	6,283,725	6,283,725	0.31	1,948,381	77.94
72	2032	6,351,204	6,351,204	0.30	1,875,528	75.02
73	2033	6,514,791	6,514,791	0.28	1,832,225	73.29
74	2034	6,382,314	6,382,314	0.27	1,709,492	68.38
75	2035	6,356,215	6,356,215	0.26	1,621,430	64.86
<b>Total</b>		<b>\$259,250,016</b>	<b>\$259,250,016</b>	<b>-</b>	<b>\$213,185,542</b>	<b>\$8,527.42</b>
<b>1961-2007</b>		<b>\$69,770,344</b>	<b>\$69,770,344</b>	<b>-</b>	<b>\$111,143,503</b>	<b>\$4,445.74</b>
<b>2008-2035</b>		<b>\$189,479,672</b>	<b>\$189,479,672</b>	<b>-</b>	<b>\$102,042,039</b>	<b>\$4,081.68</b>



**SAN LUIS OBISPO COUNTY**  
**State Water Project - CCWA Charges**

**Financial Summary (1961-2035)**

5.0%

25,000

	Year	CCWA Payments	Factor	Adjusted Payments	Adjusted per AF
1	1961	-	9.43	-	-
2	1962	-	8.99	-	-
3	1963	-	8.56	-	-
4	1964	-	8.15	-	-
5	1965	-	7.76	-	-
6	1966	-	7.39	-	-
7	1967	-	7.04	-	-
8	1968	-	6.70	-	-
9	1969	-	6.39	-	-
10	1970	-	6.08	-	-
11	1971	-	5.79	-	-
12	1972	-	5.52	-	-
13	1973	-	5.25	-	-
14	1974	-	5.00	-	-
15	1975	-	4.76	-	-
16	1976	-	4.54	-	-
17	1977	-	4.32	-	-
18	1978	-	4.12	-	-
19	1979	-	3.92	-	-
20	1980	-	3.73	-	-
21	1981	-	3.56	-	-
22	1982	-	3.39	-	-
23	1983	-	3.23	-	-
24	1984	-	3.07	-	-
25	1985	-	2.93	-	-
26	1986	-	2.79	-	-
27	1987	-	2.65	-	-
28	1988	-	2.53	-	-
29	1989	-	2.41	-	-
30	1990	-	2.29	-	-
31	1991	-	2.18	-	-
32	1992	-	2.08	-	-
33	1993	-	1.98	-	-
34	1994	-	1.89	-	-
35	1995	-	1.80	-	-
36	1996	-	1.71	-	-
37	1997	\$1,600,000	1.63	\$2,606,231	\$104.25
38	1998	1,600,000	1.55	2,482,125	99.29
39	1999	1,600,000	1.48	2,363,929	94.56
40	2000	1,600,000	1.41	2,251,361	90.05
41	2001	1,600,000	1.34	2,144,153	85.77
42	2002	1,600,000	1.28	2,042,051	81.68
43	2003	1,600,000	1.22	1,944,810	77.79
44	2004	1,600,000	1.16	1,852,200	74.09
45	2005	1,600,000	1.10	1,764,000	70.56

	Year	CCWA Payments	Factor	Adjusted Payments	Adjusted per AF
46	2006	\$1,709,356	1.05	\$1,794,824	\$71.79
47	2007	1,821,675	1.00	1,821,675	72.87
48	2008	1,838,055	0.95	1,750,529	70.02
49	2009	1,848,798	0.91	1,676,914	67.08
50	2010	1,900,000	0.86	1,641,291	65.65
51	2011	1,900,000	0.82	1,563,135	62.53
52	2012	1,900,000	0.78	1,488,700	59.55
53	2013	1,900,000	0.75	1,417,809	56.71
54	2014	1,900,000	0.71	1,350,295	54.01
55	2015	1,900,000	0.68	1,285,995	51.44
56	2016	1,900,000	0.64	1,224,757	48.99
57	2017	1,900,000	0.61	1,166,435	46.66
58	2018	1,900,000	0.58	1,110,891	44.44
59	2019	1,900,000	0.56	1,057,991	42.32
60	2020	1,900,000	0.53	1,007,611	40.30
61	2021	1,900,000	0.51	959,629	38.39
62	2022	1,900,000	0.48	913,932	36.56
63	2023	1,900,000	0.46	870,412	34.82
64	2024	1,900,000	0.44	828,964	33.16
65	2025	1,900,000	0.42	789,489	31.58
66	2026	1,900,000	0.40	751,895	30.08
67	2027	1,900,000	0.38	716,090	28.64
68	2028	1,900,000	0.36	681,990	27.28
69	2029	1,900,000	0.34	649,515	25.98
70	2030	1,900,000	0.33	618,585	24.74
71	2031	1,900,000	0.31	589,129	23.57
72	2032	1,900,000	0.30	561,075	22.44
73	2033	1,900,000	0.28	534,357	21.37
74	2034	1,900,000	0.27	508,912	20.36
75	2035	1,900,000	0.26	484,678	19.39
	<b>Total</b>	<b>\$71,017,884</b>	<b>-</b>	<b>\$51,268,363</b>	<b>\$2,050.73</b>
	<b>1961-2007</b>	<b>\$17,931,031</b>	<b>-</b>	<b>\$23,067,358</b>	<b>\$922.69</b>
	<b>2008-2035</b>	<b>\$53,086,853</b>	<b>-</b>	<b>\$28,201,005</b>	<b>\$1,128.04</b>

**SANTA BARBARA COUNTY**

**State Water Project - DWR Charges**

**Financial Summary (1961-2035)**

87.5%

5.0%

45,486

17,820

		<b>SB SWP</b>	<b>SB SWP</b>		<b>Adjusted</b>	<b>Adjusted</b>	<b>SM SWP</b>
<b>Year</b>		<b>Payments</b>	<b>Fixed</b>	<b>Factor</b>	<b>Payments</b>	<b>per AF</b>	<b>Costs</b>
1	1961	-	-	9.43	-	-	-
2	1962	-	-	8.99	-	-	-
3	1963	-	-	8.56	-	-	-
4	1964	\$21,667	\$21,667	8.15	\$176,579	\$3.88	\$69,178
5	1965	36,029	36,029	7.76	279,642	6.15	109,555
6	1966	61,349	61,349	7.39	453,491	9.97	177,664
7	1967	118,263	118,263	7.04	832,570	18.30	326,175
8	1968	229,807	229,807	6.70	1,540,799	33.87	603,637
9	1969	358,861	358,861	6.39	2,291,499	50.38	897,738
10	1970	387,675	387,675	6.08	2,357,609	51.83	923,638
11	1971	392,912	392,912	5.79	2,275,674	50.03	891,538
12	1972	406,589	406,589	5.52	2,242,751	49.31	878,640
13	1973	402,723	402,723	5.25	2,115,644	46.51	828,844
14	1974	407,090	407,090	5.00	2,036,748	44.78	797,935
15	1975	439,873	439,873	4.76	2,095,969	46.08	821,135
16	1976	447,299	447,299	4.54	2,029,861	44.63	795,236
17	1977	468,721	468,721	4.32	2,025,785	44.54	793,640
18	1978	484,259	484,259	4.12	1,993,276	43.82	780,903
19	1979	483,437	483,437	3.92	1,895,135	41.66	742,455
20	1980	540,553	540,553	3.73	2,018,131	44.37	790,641
21	1981	596,670	596,670	3.56	2,121,563	46.64	831,162
22	1982	682,546	682,546	3.39	2,311,343	50.81	905,512
23	1983	702,083	702,083	3.23	2,264,288	49.78	887,078
24	1984	801,057	801,057	3.07	2,460,466	54.09	963,934
25	1985	969,931	969,931	2.93	2,837,301	62.38	1,111,566
26	1986	1,038,030	1,038,030	2.79	2,891,913	63.58	1,132,961
27	1987	1,148,974	1,148,974	2.65	3,048,570	67.02	1,194,335
28	1988	1,439,620	1,439,620	2.53	3,637,848	79.98	1,425,196
29	1989	1,814,759	1,814,759	2.41	4,367,434	96.02	1,711,025
30	1990	2,046,370	2,046,370	2.29	4,690,318	103.12	1,837,521
31	1991	2,366,841	2,366,841	2.18	5,166,517	113.58	2,024,081
32	1992	2,526,860	2,526,860	2.08	5,253,160	115.49	2,058,025
33	1993	2,726,057	2,726,057	1.98	5,397,406	118.66	2,114,536
34	1994	3,518,043	3,518,043	1.89	6,633,795	145.84	2,598,914
35	1995	6,195,415	6,195,415	1.80	11,126,075	244.60	4,358,850
36	1996	15,232,541	15,232,541	1.71	26,052,814	572.77	10,206,682
37	1997	23,737,163	20,770,018	1.63	33,832,170	743.79	13,254,392
38	1998	28,312,394	24,773,345	1.55	38,431,589	844.91	<b>15,107,191</b>
39	1999	29,594,819	25,895,467	1.48	38,259,398	841.12	<b>16,051,756</b>
40	2000	30,850,550	26,994,231	1.41	37,983,594	835.06	<b>16,015,884</b>
41	2001	32,744,802	28,651,702	1.34	38,396,021	844.13	<b>14,774,729</b>
42	2002	32,532,341	28,465,798	1.28	36,330,374	798.72	<b>14,493,300</b>
43	2003	32,800,868	28,700,760	1.22	34,885,953	766.96	<b>14,637,588</b>
44	2004	34,403,279	30,102,869	1.16	34,847,834	766.12	<b>14,492,412</b>
45	2005	37,198,952	32,549,083	1.10	35,885,364	788.93	<b>14,136,806</b>

Year	SB SWP Payments	SB SWP Fixed	Factor	Adjusted Payments	Adjusted per AF	SM SWP Costs	
46	2006	\$36,411,846	\$31,860,365	1.05	\$33,453,384	\$735.47	<b>\$13,650,011</b>
47	2007	36,430,491	31,876,680	1.00	31,876,680	700.80	<b>16,989,870</b>
48	2008	36,048,882	31,542,772	0.95	30,040,735	660.44	<b>13,605,134</b>
49	2009	36,040,827	31,535,724	0.91	28,603,831	628.85	11,206,091
50	2010	36,215,319	31,688,404	0.86	27,373,635	601.80	10,724,139
51	2011	36,427,739	31,874,272	0.82	26,223,042	576.51	10,273,372
52	2012	36,581,162	32,008,517	0.78	25,079,510	551.37	9,825,372
53	2013	36,613,887	32,037,151	0.75	23,906,615	525.58	9,365,868
54	2014	36,414,917	31,863,052	0.71	22,644,476	497.83	8,871,402
55	2015	36,556,902	31,987,289	0.68	21,650,256	475.98	8,481,897
56	2016	36,671,275	32,087,366	0.64	20,683,802	454.73	8,103,270
57	2017	36,479,119	31,919,229	0.61	19,595,638	430.81	7,676,961
58	2018	36,169,533	31,648,341	0.58	18,504,130	406.81	7,249,342
59	2019	36,495,806	31,933,830	0.56	17,781,952	390.93	6,966,416
60	2020	35,972,863	31,476,255	0.53	16,692,530	366.98	6,539,614
61	2021	36,122,874	31,607,515	0.51	15,963,943	350.96	6,254,176
62	2022	35,770,597	31,299,272	0.48	15,055,485	330.99	5,898,271
63	2023	35,870,680	31,386,845	0.46	14,378,675	316.11	5,633,118
64	2024	35,991,994	31,492,995	0.44	13,740,289	302.08	5,383,018
65	2025	35,590,793	31,141,944	0.42	12,940,121	284.49	5,069,537
66	2026	35,534,529	31,092,713	0.40	12,304,442	270.51	4,820,498
67	2027	35,371,264	30,949,856	0.38	11,664,675	256.45	4,569,857
68	2028	35,272,392	30,863,343	0.36	11,078,161	243.55	4,340,079
69	2029	35,185,830	30,787,601	0.34	10,524,738	231.38	4,123,265
70	2030	33,373,632	29,201,928	0.33	9,507,310	209.02	3,724,668
71	2031	33,249,467	29,093,284	0.31	9,020,894	198.32	3,534,106
72	2032	33,371,350	29,199,931	0.30	8,622,821	189.57	3,378,153
73	2033	33,675,215	29,465,813	0.28	8,286,987	182.19	3,246,584
74	2034	33,431,949	29,252,955	0.27	7,835,355	172.26	3,069,648
75	2035	33,379,213	29,206,811	0.26	7,450,472	163.80	2,918,863
<b>Total</b>	<b>\$1,398,390,419</b>	<b>\$1,229,778,229</b>	-	<b>\$980,258,854</b>	<b>\$21,550.78</b>	<b>\$395,046,588</b>	
<b>1961-2007</b>	<b>\$404,510,409</b>	<b>\$360,133,221</b>	-	<b>\$513,104,334</b>	<b>\$11,280.49</b>	<b>\$210,193,869</b>	
<b>2008-2035</b>	<b>\$993,880,010</b>	<b>\$869,645,009</b>	-	<b>\$467,154,521</b>	<b>\$10,270.29</b>	<b>\$184,852,719</b>	

**SANTA BARBARA COUNTY**  
**State Water Project - CCWA Charges**

**Financial Summary (1961-2035)**

5.0% 45,486 17,820

	<b>Year</b>	<b>CCWA Payments</b>	<b>Factor</b>	<b>Adjusted Payments</b>	<b>Adjusted per AF</b>	<b>SM SWP Costs</b>
1	1961	-	9.43	-	-	-
2	1962	-	8.99	-	-	-
3	1963	-	8.56	-	-	-
4	1964	-	8.15	-	-	-
5	1965	-	7.76	-	-	-
6	1966	-	7.39	-	-	-
7	1967	-	7.04	-	-	-
8	1968	-	6.70	-	-	-
9	1969	-	6.39	-	-	-
10	1970	-	6.08	-	-	-
11	1971	-	5.79	-	-	-
12	1972	-	5.52	-	-	-
13	1973	-	5.25	-	-	-
14	1974	-	5.00	-	-	-
15	1975	-	4.76	-	-	-
16	1976	-	4.54	-	-	-
17	1977	-	4.32	-	-	-
18	1978	-	4.12	-	-	-
19	1979	-	3.92	-	-	-
20	1980	-	3.73	-	-	-
21	1981	-	3.56	-	-	-
22	1982	-	3.39	-	-	-
23	1983	-	3.23	-	-	-
24	1984	-	3.07	-	-	-
25	1985	-	2.93	-	-	-
26	1986	-	2.79	-	-	-
27	1987	-	2.65	-	-	-
28	1988	-	2.53	-	-	-
29	1989	-	2.41	-	-	-
30	1990	-	2.29	-	-	-
31	1991	-	2.18	-	-	-
32	1992	-	2.08	-	-	-
33	1993	-	1.98	-	-	-
34	1994	-	1.89	-	-	-
35	1995	-	1.80	-	-	-
36	1996	-	1.71	-	-	-
37	1997	-	1.63	-	-	-
38	1998	\$6,000,000	1.55	\$9,307,969	\$204.63	<b>\$4,669,527</b>
39	1999	6,000,000	1.48	8,864,733	194.89	<b>2,995,970</b>
40	2000	6,000,000	1.41	8,442,603	185.61	<b>645,336</b>
41	2001	6,000,000	1.34	8,040,574	176.77	<b>2,582,581</b>
42	2002	6,000,000	1.28	7,657,689	168.35	<b>2,533,395</b>
43	2003	7,000,000	1.22	8,508,544	187.06	<b>2,279,132</b>
44	2004	8,000,000	1.16	9,261,000	203.60	<b>2,243,797</b>
45	2005	10,000,000	1.10	11,025,000	242.38	<b>1,620,213</b>

Year	CCWA Payments	Factor	Adjusted Payments	Adjusted per AF	SM SWP Costs	
46	2006	\$12,000,000	1.05	\$12,600,000	\$277.01	<b>\$2,232,879</b>
47	2007	13,422,158	1.00	13,422,158	295.08	<b>2,633,619</b>
48	2008	14,916,967	0.95	14,206,635	312.33	<b>2,538,813</b>
49	2009	15,651,700	0.91	14,196,553	312.11	5,561,768
50	2010	15,799,633	0.86	13,648,317	300.06	5,346,986
51	2011	16,000,000	0.82	13,163,240	289.39	5,156,948
52	2012	16,000,000	0.78	12,536,419	275.61	4,911,379
53	2013	16,000,000	0.75	11,939,446	262.49	4,677,504
54	2014	16,000,000	0.71	11,370,901	249.99	4,454,765
55	2015	16,000,000	0.68	10,829,430	238.08	4,242,634
56	2016	16,000,000	0.64	10,313,743	226.75	4,040,604
57	2017	16,000,000	0.61	9,822,612	215.95	3,848,194
58	2018	16,000,000	0.58	9,354,869	205.66	3,664,947
59	2019	16,000,000	0.56	8,909,399	195.87	3,490,425
60	2020	16,000,000	0.53	8,485,142	186.54	3,324,215
61	2021	16,000,000	0.51	8,081,087	177.66	3,165,919
62	2022	16,000,000	0.48	7,696,274	169.20	3,015,161
63	2023	16,000,000	0.46	7,329,784	161.14	2,871,582
64	2024	16,000,000	0.44	6,980,747	153.47	2,734,840
65	2025	16,000,000	0.42	6,648,330	146.16	2,604,609
66	2026	16,000,000	0.40	6,331,743	139.20	2,480,580
67	2027	16,000,000	0.38	6,030,232	132.57	2,362,457
68	2028	16,000,000	0.36	5,743,078	126.26	2,249,959
69	2029	16,000,000	0.34	5,469,598	120.25	2,142,818
70	2030	16,000,000	0.33	5,209,141	114.52	2,040,779
71	2031	16,000,000	0.31	4,961,087	109.07	1,943,599
72	2032	16,000,000	0.30	4,724,844	103.87	1,851,047
73	2033	16,000,000	0.28	4,499,852	98.93	1,762,902
74	2034	16,000,000	0.27	4,285,573	94.22	1,678,954
75	2035	16,000,000	0.26	4,081,498	89.73	1,599,004
<b>Total</b>	<b>\$526,790,458</b>	<b>-</b>	<b>\$333,979,843</b>	<b>\$7,342.48</b>	<b>\$114,199,841</b>	
<b>1961-2007</b>	<b>\$80,422,158</b>	<b>-</b>	<b>\$97,130,269</b>	<b>\$2,135.39</b>	<b>\$21,802,831</b>	
<b>2008-2035</b>	<b>\$446,368,300</b>	<b>-</b>	<b>\$236,849,573</b>	<b>\$5,207.09</b>	<b>\$92,397,010</b>	

## WHOLESALE WATER SUPPLY AGREEMENT

This Wholesale Water Supply Agreement (“Agreement”) is made and entered into as of 1-5-2010, by and between the CITY OF SANTA MARIA ("City"), a California municipal corporation, and NIPOMO COMMUNITY SERVICES DISTRICT ("NCSD"), an independent special district formed under and pursuant to Section 61000, *et seq.* of the California Government Code. City and NCSD are sometimes individually referred to herein as a “Party” and collectively as the “Parties”.

### RECITALS

A. The City provides retail potable water service to customers within its service area in the Santa Maria Valley, in northern Santa Barbara County. The City holds a contract with the Central Coast Water Authority to receive water from the State Water Project (“SWP”). City also holds rights to recharge from Twitchell reservoir and rights to pump groundwater from the Santa Maria Groundwater Basin (“Santa Maria Basin”).

B. NCSD provides retail potable water service and sewer service within its established boundaries located in and around the Nipomo Mesa Management Area (“NMMA”) of the Santa Maria Basin.

C. Both the City and the NCSD are Parties to a certain groundwater adjudication lawsuit commonly referred to as the Santa Maria Groundwater Litigation (Santa Maria Valley Water Conservation District vs. City of Santa Maria, et al.; Superior Court of California, County of Santa Clara Case no. 1-97-CV-770214) (herein the “Basin Litigation”). On August 3, 2005, the Court approved a Settlement Stipulation (herein the “Stipulation”) that was signed by the Parties, related to the Basin Litigation which, among other things, provides that “the NCSD and City shall employ their best efforts to timely implement the Nipomo Supplemental Water Project, subject to their quasi-judicial obligations specified for administrative action and in the California Environmental Quality Act.” The Stipulation was later incorporated into the final Judgment.

D. On a long term basis, City has water available for use in the NMMA that is surplus to that needed to serve City's current and long-term future anticipated demands.

E. Pursuant to the Stipulation, NCSD seeks to acquire a Supplemental Water supply (referred to herein as "Supplemental Water") to alleviate pressure on the NMMA from groundwater pumping and to meet current needs and projected demands of NCSD customers.

F. Consistent with the Stipulation and Judgment, and subject to the terms and conditions of this Agreement, City is willing to sell and deliver to NCSD an established quantity of Supplemental Water on a wholesale basis.

NOW THEREFORE, in consideration of the foregoing recitals and the promises and covenants contained herein, the Parties agree as follows:

1. **Purpose.** Consistent with the Stipulation and Judgment, the purpose of this Agreement is to formalize the terms and conditions by which City will provide Supplemental Water to NCSD, including an equivalent amount of capacity in City's water distribution system, for delivery to the NCSD water distribution system through the interconnection described in Paragraph 9, beginning on the Effective Date and continuing each year thereafter for as long as this Agreement remains in effect.

2. **Termination of MOU.** City and NCSD executed a Memorandum of Understanding ("MOU") on September 7, 2004, to provide for the reservation of a Supplemental Water supply of up to three thousand (3,000) acre-feet per year in anticipation of the negotiation of this Agreement. This Agreement shall supercede the terms of the MOU, which shall terminate and be of no further force or effect. The initial reservation payment of \$37,500 that was made upon execution of the MOU shall be credited by City to the first quarterly invoice for water delivery pursuant to Paragraph 8.



3. **Term of Agreement.**

(a) **Contract Term.** The term of the Agreement shall commence on the Effective Date and end on June 30, 2085 ("Term"). Notwithstanding the Term, the delivery of Supplemental Water pursuant to this Agreement during any period on or after June 30, 2035, shall be subject to the renewal of the contract between the City and Central Coast Water Authority for SWP water. Furthermore, the terms of this Agreement shall be subject to renegotiation as described below in the event that the SWP contract or any subsequent SWP contract is not renewed or the terms of such renewal either (i) substantially impair the ability of City to continue to provide Supplemental Water in the quantities set forth in this Agreement; or (ii) the cost of continuing to provide Supplemental Water pursuant to the terms of this Agreement would create a significant financial burden on the City. In no event shall the City be required to deliver Supplemental Water following June 30, 2035 at a financial loss. Upon the occurrence of one of the foregoing events and within thirty (30) days of a written request from City to NCSO requesting renegotiation, the Parties shall negotiate in good faith and use their best efforts to equitably amend the terms of this Agreement to allow for the continued delivery of Supplemental Water on terms that are mutually beneficial to the Parties for the duration of the Term. The parties will meet in good faith in 2085 to determine whether to extend the term of the Agreement.

(b) **Dispute Resolution.** In the event of a dispute as to whether clause (i) and/or (ii) of Paragraph 3(a) have been triggered as a result of the renegotiation or non-renewal of the SWP contract, then such dispute shall be referred to the dispute resolution procedures referenced in Paragraph 19 of this Agreement. If a final finding is made as a result of such dispute resolution procedure that clause (i) and/or clause (ii) have been triggered, then the Parties shall negotiate in good faith pursuant to Paragraph 3(a). If the Parties cannot agree on the terms and conditions for equitably amending the terms of this Agreement to address a substantial impairment pursuant to clause (i) of Paragraph 3(a), then whether or not there is a feasible solution to address such substantial impairment may also be referred to the dispute resolution procedures referenced in Paragraph 19 of this Agreement. Notwithstanding the foregoing, the allocation of cost and/or any revision in the price of Supplemental Water to implement a solution

or address the existence of an impairment or significant financial burden as set forth in Paragraph 3(a) shall be solely determined by the Parties on mutually acceptable terms and the dispute resolution procedure shall have no authority to order or impose any change with respect to such terms.

(c) **Effective Date.** The "Effective Date" shall mean the date that the NCSD interconnection described in Paragraph 9 has been completed and approved by City's technical staff as operationally ready for commencement of delivery of Supplemental Water.

(d) **Delivery Year.** Each "Delivery Year" shall commence on the Effective Date and any anniversary thereof during the Term and continue for a period of one (1) year.

4. **Quantity of Supplemental Water.**

(a) **Minimum Delivery.** In each Delivery Year during the Term of this Agreement, City shall deliver and NCSD shall purchase the following minimum quantity of Supplemental Water ("Minimum Quantity"):

Delivery Years 1 through 10	-	2,000 acre feet per year
Delivery Years 11 through 19	-	2,500 acre feet per year
Delivery Years 20 through end of Term	-	3,000 acre feet per year

Any portion of the Minimum Quantity of Supplemental Water that is not taken by NCSD during a given Delivery Year shall be forfeit and shall not roll over to the next year. In the event that City, in its sole and absolute discretion, agrees to deliver unused Supplemental Water in a subsequent Delivery Year, such late delivery shall be an accommodation to NCSD and shall not constitute a waiver or amendment to the terms of this Agreement.

(b) **Additional Delivery.** NCSD may request delivery of Supplemental Water in excess of the Minimum Quantity up to an additional 3,200 acre feet per year. NCSD shall give City no less than thirty (30) days written notice of its desire to purchase additional

Supplemental Water and the proposed schedule for such delivery. City shall make a good faith effort to comply with such request subject to (i) the availability of excess Supplemental Water from sources used for delivery of water to City's retail customers; and (ii) sufficient delivery capacity to fulfill such request at the NCSD interconnection using the City's existing water distribution system. Any such additional Supplemental Water shall be purchased and delivered on the same terms as the Minimum Quantity, provided, however, that if the cost of procuring and delivering additional Supplemental Water exceeds the cost of delivering the Minimum Quantity, City shall have the right to impose a surcharge to compensate City for such additional cost as a condition to delivery. City shall notify NCSD of the amount of any such surcharge prior to delivery of any additional Supplemental Water and NCSD shall have the right to withdraw its request. In no event shall City be required to undertake any capital cost or expansion of its existing infrastructure to provide additional Supplemental Water.

5. **Reservation of Minimum Quantity.** Subject to the terms and conditions of this Agreement, City shall hold on reserve sufficient Supplemental Water each year, including an equivalent amount of capacity in City's water distribution system, for City to fulfill its obligation to deliver the Minimum Quantity to NCSD under this Agreement. City shall deliver such Supplemental Water to NCSD from sources used to provide water to City's retail customers. Notwithstanding the foregoing, during the term of the Agreement, City may substitute or combine new or additional replacement sources of water for the source of Supplemental Water, provided, however, that any substitute, combined or additional sources must be equivalent in deliverability, reliability, quality, pressure, and environmental impacts to the source being replaced. Disputes regarding this Paragraph shall be resolved pursuant to Paragraph 19.

6. **Purchase Price for Supplemental Water.** The purchase price for Supplemental Water delivered by City to NCSD shall be based on the "Base Rate" of the City's Water Consumption Rates. For fiscal year 2008-09, the Base Rate is \$2.441 per one hundred cubic feet of water (or \$1,063.37 per acre-foot of water). The Base Rate may be adjusted each fiscal year subject to approval by the City Council, consistent with applicable legal requirements. Any such adjustment in the purchase price shall go into effect in the next quarterly billing period.

7. **Costs of Delivery.** Except as expressly set forth in this Agreement, City shall be responsible for all costs and expenses related to providing Supplemental Water to NCSD at the NCSD interconnection pursuant to this Agreement. Notwithstanding the foregoing, the purchase price for Supplemental Water includes a cost component for energy costs incurred by City to supply Supplemental Water to the NCSD interconnection equal to two hundred and six dollars and eighty five cents (\$206.85) per acre foot ("Base Energy Cost"). In the event that the actual cost of energy incurred by City to supply Supplemental Water in any Delivery Year exceeds the Base Energy Cost, then City shall have the right to charge NCSD a premium equal to the difference between the actual cost and the Base Energy Cost. The Base Energy Cost shall be adjusted each Delivery Year by a percentage which is equivalent to fifty percent (50%) of the increase or decrease, if any, in the Consumer Price Index - Energy Services (Electricity and Natural Gas) - Los Angeles-Riverside-Orange County or any successor index.

8. **Payments for Supplemental Water.** City shall bill NCSD on a quarterly basis in arrears for Supplemental Water delivered to NCSD's interconnection during the previous three (3) months. The amount payable by NCSD to City shall be based on the total quantity in acre-feet of Supplemental Water delivered during the quarter just ended multiplied by the then-current purchase price (as determined in Paragraph 6), plus any costs payable by NCSD pursuant to this Agreement. Notwithstanding the foregoing, to the extent that NCSD has taken less than the Minimum Quantity as of the final quarterly billing for a Delivery Year, City shall bill NCSD for the remainder of the Minimum Quantity whether or not such Supplemental Water has been delivered, provided that such water was made available for delivery to NCSD as provided in Paragraph 9. All invoices billed to NCSD shall be payable within thirty (30) days of the invoice date, provided that no charges are disputed. City shall have the right to charge late fees of up to five percent (5%) of the overdue amount for any invoice that is not paid within such period. In the event NCSD disputes any charges on an invoice, the undisputed amount shall be paid consistent with this Paragraph and the original invoice shall be returned to City for correction and resubmission. If the parties are unable to reach an agreement regarding disputed charges, disputes shall be resolved pursuant to Paragraph 19.

9. **Delivery of Water.**

(a) **Point of Delivery.** The physical point of delivery of Supplemental Water pursuant to this Agreement shall be the proposed interconnection between the City water distribution system and the NCSD water distribution system located at Taylor Street and Blosser Road or such other alternative location as may be approved by City and NCSD. All facilities constructed by NCSD will be used solely for the purpose of delivering Supplemental Water to NCSD. NCSD shall cooperate with the reasonable requests of City with respect to taking any action necessary to preserve the integrity of the City's water distribution system and the City shall do likewise for NCSD. The operation and maintenance of the NSCD Interconnection will be detailed in an Operation Memorandum of Understanding that will be approved by the City and NCSD prior to connection. City shall waive any fees for City permits related to construction of facilities for delivery of the water. If the parties cannot agree on the terms of the Operations Memorandum of Understanding then the disputed terms will be subject to the dispute resolution procedures referenced in Paragraph 19 of this Agreement.

(b) **Facilities.** NCSD shall be responsible for designing, constructing and operating the NCSD interconnect. The plans and specifications of the NCSD interconnect shall be subject to prior approval by City, which approval shall not unreasonably be withheld provided that such plans and specifications conform to applicable code provisions and any technical requirements imposed for connections to the City's water distribution system. NCSD shall also be responsible for obtaining any and all regulatory and environmental permits, licenses or other approvals necessary to construct and operate the NCSD interconnection. NCSD and/or any contractor working on the NCSD interconnect shall provide insurance coverage naming the City as an additional insured and the scope of such insurance coverage shall be subject to the reasonable approval of City's risk manager prior to commencement of any work.

(c) **Construction, Regulatory/ Permit and Other Costs.** NCSD shall be solely responsible for all costs related to the construction and operation of the NCSD interconnection with City's retail water distribution system. NCSD shall also be solely

responsible for all regulatory and/or permit compliance and costs with respect to the NCSD interconnection.

(d) **City Streets: License to Use Easements and Rights of Way.** The City shall provide NCSD a license, at no additional cost, to use such portions of City streets, easements, and right of ways as are reasonably necessary to build the NCSD interconnect and deliver the Supplemental Water to NCSD. Such license shall be non-revocable during the Term of this Agreement and shall automatically terminate upon the termination of this Agreement. The foregoing licenses shall not include the right of NCSD to make any alteration or improvement within such City streets, easements and rights of way except in compliance with Paragraph 9.

(e) **Delivery Schedule.** City will deliver the Supplemental Water to NCSD at the NCSD interconnection upon a mutually agreeable delivery schedule. The volume of delivery to the NCSD interconnection shall not exceed a maximum of two hundred and seventy-five (275) acre-feet per month or a peak hour flow averaging 2500 gallons per minute. Delivery pressure at the point of connection shall exceed 60 psi during City's normal system operation, not including emergencies or incidents described in 9(f). Before delivery begins, the District and City shall agree to an Operation Memorandum of Understanding (OMOU) to describe the specific procedures and limitation on the operations provided for in this Agreement.

(f) **Force Majeure.** If by reason of acts of God, earthquakes, droughts, floods, storms, explosion, fires, labor troubles, strikes, insurrection, riots, acts of the public enemy, or federal, or state, order, rule, or regulation, the City is prevented, in whole or in part, from the delivery of the Supplemental Water to NCSD, as provided herein, then City may reduce delivery of Supplemental Water up to the same percentage the City reduces water delivery to its retail customers.

(g) **Suspension.** The delivery of water may be suspended or curtailed during any period of public emergency or disaster that is declared by City. For the purposes of this Agreement, a public emergency or disaster shall not include ordinary measures taken during

periods of drought or water shortage.

(h) **Obligations of City.** For the purposes of this Agreement and subject the limitations contained in this Paragraph 9, City shall have fulfilled its obligation to make Supplemental Water available for delivery so long as the amount of Supplemental Water purchased by NCSD is available at the NCSD interconnection for NCSD to take delivery of pursuant to a predetermined and mutually agreed upon delivery schedule.

10. **Water Quality.** City shall be responsible for ensuring that the quality of the Supplemental Water made available for delivery is of the same pressure and quality of water that City delivers to its residential customers. The quality of water which is delivered by the City to its residents complies with federal, state and local laws, regulations and permit requirements which are applicable to City, including standards applicable to wastewater discharge, as amended from time to time and subject to any compliance waiver granted to the City ("Quality Standards"). City shall provide NCSD with a copy of the Quality Standards (and any change thereto) which are applicable to City and NCSD shall be solely responsible for ensuring that the Quality Standards meet the federal, state and local laws, regulations and permit requirements for potable water delivery by NCSD to its customers, including the discharge of such water. To the extent that the quality standards which are applicable to NCSD exceed the Quality Standards, then NCSD shall be responsible for any necessary additional treatment of the Supplemental Water. City agrees to indemnify and hold NCSD harmless from any actual liability which arises as a result of the failure of Supplemental Water which is delivered to the NCSD interconnection to meet the Quality Standards. NCSD shall be solely responsible for any actual liability resulting from a change in water quality following the point of delivery (including any additional treatment undertaken by NCSD) and shall indemnify and hold City harmless from any actual liability which arises from any such change. City and NCSD shall promptly notify the other in the event that either becomes aware of a material adverse change in the quality of the Supplemental Water and shall cooperate to identify the cause of such change.

11. **Remarketing of Supplemental Water.** NCSD shall be free to remarket the Supplemental Water to other Parties within the NMMA without restriction to price and terms.

NCSO assumes all responsibility for delivery of Supplemental Water from the NCSO interconnection to its customers and contracting Parties. City's obligations under this Agreement are solely with NCSO and no customer of NCSO nor other third party shall have the right to enforce the terms of this Agreement as a third party beneficiary. City shall not sell water to other parties or persons within NCSO's service area or sphere of influence, as amended from time to time, without first receiving the written approval of NCSO.

12. **Regulatory Requirements.**

(a) **Obligations of the City.** The implementation of this Agreement shall be subject to satisfaction by City of the regulatory requirements set forth herein. City shall, if necessary, undertake the following: (i) Obtain all permits, consents, entitlements and approvals necessary to enable the City to reserve and sell, and NCSO to purchase, the Supplemental Water that is the subject of this Agreement; and (ii) fully and completely comply with the requirements of the California Environmental Quality Act ("CEQA"), including, if it is determined that this transaction is subject to CEQA and not exempt from CEQA, the completion of an initial study, and (1) either (a) there shall have been adopted a negative declaration or a mitigated negative declaration, or (b) a final environmental impact report shall have been completed and certified, and (2) the time shall have expired within which a judicial proceeding may be instituted challenging the validity or completeness of any such determination of exemption, or adoption of a negative declaration or of a mitigated negative declaration, or approval of a final environmental impact report.

(b) **Obligations of NCSO.** NCSO shall be solely responsible for obtaining all regulatory approvals necessary in connection with purchasing and taking delivery of the Supplemental Water.

13. **Service Area Integrity.** Nothing in this Agreement is intended nor shall it be interpreted to waive the right of City to provide water service to current or future areas within or adjacent to its existing service area.



**14. Representations or Warranties of City.** City makes the following representations, warranties and covenants to NCSD:

(a) **Power and Authority to Execute and Perform this Agreement.** The City has the power and authority to enter into this Agreement and to perform its obligations and all necessary approvals and authorizations have been obtained.

(b) **Availability of Resource.** Based on information which is currently known to City and City's current forecast of future use, on a long-term basis, City has water and the necessary infrastructure available to fulfill City's obligations under this Agreement that is surplus to that needed to serve City's current and long-term future anticipated demand.

(c) **Enforceability.** This Agreement constitutes a legal, valid and binding obligation of the City, and is enforceable against the City in accordance with its terms.

**15. Representations or Warranties of NCSD.** NCSD makes the following representations, warranties and covenants to City:

(a) **Power and Authority to Execute and Perform this Agreement.** NCSD has the power and authority to enter into this Agreement and to perform its obligations and all necessary approvals and authorizations have been obtained.

(b) **Enforceability.** This Agreement constitutes a legal, valid and binding obligation of NCSD, enforceable against NCSD in accordance with its terms.

**16. Default and Termination by City.** In the event NCSD fails to make any payment to City under this Agreement when due, or fails to perform any obligation otherwise required by this Agreement, City shall demand in writing that NCSD cure such non-performance. NCSD shall have thirty (30) days after receipt of such demand to cure. In the event NCSD fails to cure a default within the thirty (30) day period, City may suspend delivery of Supplemental Water and redirect such water to other uses for the duration of the suspension. City shall restore

water delivery when NCSD has cured all outstanding defaults and paid all amounts due to the City in full. In the event that NCSD does not cure a default within one (1) year of suspension, then City may terminate this Agreement at any time thereafter.

17. **Default and Termination by NCSD.** NCSD shall have the right to terminate this Agreement, without recourse, if (i) the City is found to be in material breach of its obligations to deliver the Supplemental Water as set forth in this agreement; or (ii) upon written notice to City that NCSD is unable to pay for the Supplemental Water due to the majority protest procedures or other procedures referenced in Proposition 218; or (iii) upon three (3) years prior written notice to City, provided, however, that no such termination without cause shall become effective until the thirtieth (30<sup>th</sup>) anniversary of the Effective Date.

18. **Expiration of Term.** This Agreement shall terminate and be of no further force and effect as of the expiration of the Term.

19. **Dispute Resolution.** Except as otherwise limited by this Agreement, any dispute arising under this Agreement, including, without limitation, all disputes relating in any manner to the performance or enforcement of this Agreement, shall be resolved by binding arbitration in the County of Santa Barbara, California, pursuant to the comprehensive arbitration rules and procedures of Judicial Arbitration and Mediation Services (“JAMS”) or any successor thereto, as amended or as augmented in this Agreement (the “Rules”). Arbitration shall be initiated as provided by the Rules, although the written notice to the other party initiating arbitration shall also include a description of the claim(s) asserted and the facts upon which the claim(s) are based. Arbitration shall be final and binding upon the parties and shall be the exclusive remedy for all claims subject hereto, including any award of attorney’s fees and costs. Either party may bring an action in court to compel arbitration under this Agreement and to enforce an arbitration award. All disputes shall be decided by a single arbitrator. The arbitrator shall be selected by mutual agreement of the parties within thirty (30) days of the effective date of the notice initiating the arbitration. If the parties cannot agree on an arbitrator, then the complaining party shall notify JAMS and request selection of an arbitrator in accordance with the Rules. The arbitrator shall have only such authority to award equitable relief, damages, costs, and fees as a

court would have for the particular claim(s) asserted. In no event shall the arbitrator award punitive damages of any kind. The parties acknowledge that one of the purposes of utilizing arbitration is to avoid lengthy and expensive discovery and allow for prompt resolution of the dispute. The arbitrator shall have the power to limit or deny a request for documents or a deposition if the arbitrator determines that the request exceeds those matters which are directly relevant to the claims in controversy. The parties may make a motion for protective order or motion to compel before the arbitrator with regard to the discovery, as provided in the Code of Civil Procedure. Notwithstanding the election by the parties to arbitrate their disputes, nothing contained herein shall prevent a party from filing an action in a court of competent jurisdiction to seek any form of equitable remedy or relief.

20. **Indemnity.** NCSD, its successors and assigns, shall hold harmless, defend and indemnify City, its officials, employees, agents, successors and assigns (all of which are herein referred to as the “City Indemnified Parties”) from and against all liabilities, obligations, claims, damages, losses, actions, judgments, suits, costs and expenses, including but not limited to reasonable attorneys’ fees (collectively, “Damages”), which may be imposed on, incurred by, or asserted against City Indemnified Parties as a result of (i) a breach of NCSD’s obligations; or (ii) the conduct of NCSD’s operations associated with the NCSD interconnection to City’s retail distribution system and the subsequent delivery of Supplemental Water to NCSD’s customers. Notwithstanding the foregoing, in no event shall NCSD be liable to indemnify a City Indemnified Party for (i) any Damages resulting from the negligence or willful misconduct of City; (ii) any third party claim brought in connection with regulatory approvals; or (iii) any claim brought in connection with the quality of the Supplemental Water as provided in Paragraph 10 above. This indemnification shall survive termination of the Agreement.

21. **Third Party Claims.** Promptly following notice of any “Third Party Claim” for which City is indemnified hereunder, City shall notify NCSD of such claim in writing. NCSD shall have a period of thirty (30) days following the receipt of such notice to notify City of whether NCSD elects to assume the defense thereof. If NCSD so notifies City that it elects to assume the defense, NCSD thereafter shall undertake and diligently pursue the defense of the Third Party Claim. NCSD shall not consent to entry of judgment or enter into any settlement

agreement, without the consent of City, which does not include a complete and unconditional release of City or which imposes injunctive or other equitable relief against City. City shall be entitled to participate in, but not control, the defense thereof, with counsel of its choice and at its own expense. If NCSD does not give the requisite notice, or fails to assume and diligently pursue the defense of such Third Party Claim, City may defend against such Third Party Claim in such manner as it may deem appropriate, at NCSD's expense, including without limitation settlement thereof on such terms as City may deem appropriate, and to pursue such remedies as may be available to City against NCSD. Notwithstanding the foregoing, City shall not consent to entry of a judgment or enter into any settlement agreement, without the consent of NCSD, which does not include a complete and unconditional release of NCSD.

22. **Notice of Claims.** The Parties shall promptly notify each other within ten (10) days of City or NCSD becoming aware of: (1) any claims or suits brought against City or NCSD which involve this Agreement or water supplied to NCSD pursuant to this Agreement, (2) any Third Party Claims, and (3) any force majeure event. Any such notice shall conform to the requirements specified in Paragraph 28 of this Agreement.

23. **Remedies Not Exclusive.** Remedies provided in this Agreement for enforcement of its terms are intended and shall be construed as cumulative rather than exclusive and shall not be deemed to deprive either Party from also using any other remedies provided by this Agreement or by law.

24. **No Transfer of Rights.** The rights granted to NCSD hereunder constitute the right to take delivery of Supplemental Water only and shall not be interpreted as a sale, transfer, or assignment of any of City's water rights.

25. **Subject to Applicable Law.** The Parties acknowledge and agree that this Agreement and the rights and obligations of the Parties shall be subject to the laws governing municipal corporations and special districts as they now exist and as they may be amended or codified by the Legislature of the State of California.

26. **Entire Agreement.** This Agreement contains the entire understanding between NCSD and City with respect to its subject matter, and supersedes all prior agreements, oral or written, and all prior or contemporaneous discussions or negotiations between NCSD and City. This Agreement cannot be amended except in writing signed by both Parties.

27. **No Waiver.** Any failure or delay on the part of either Party to exercise any right under this Agreement shall not constitute a waiver of the right, and shall not preclude such Party from exercising or enforcing the right, or any other provision of this Agreement, on any subsequent occasion.

28. **Notices.** All notices or other communications required or desired to be given pursuant to this Agreement shall be in writing and shall be hand-delivered or sent by a reputable overnight courier service providing delivery confirmation. Each such notice or communication shall be deemed to be duly given when hand-delivered or one (1) day after being deposited for next day delivery with an overnight courier. Each such notice or communication shall be addressed to the Parties at their respective addresses set forth next to their signatures below, or such other address as a Party notifies the other in writing.

29. **Headings; Paragraph References.** Captions and headings appearing in this Agreement are inserted solely as reference aids for the ease and convenience; they shall not be deemed to define or limit the scope or substance of the provisions they introduce, nor shall they be used in construing the intent or effect of such provisions.

30. **Separability.** If any provision of this Agreement is finally determined by a court to be invalid or unenforceable as written, the provision shall, if possible, be enforced to the extent reasonable under the circumstances and otherwise shall be deemed deleted from this Agreement. The other provisions of this Agreement shall remain in full force and effect so long as the material purposes of the Agreement and understandings of the Parties are not impaired.

31. **Binding Effect Assignment.** This Agreement shall be binding on and inure to the benefit of the Parties, and their respective successors and permitted assigns. NCSD shall

have the right to assign its rights under this Agreement with the written consent of City, provided, however, that the City shall not unreasonably withhold such consent and further provided that the assignee agrees to be bound by all of the obligations of NCSD set forth herein. Notwithstanding the foregoing, no assignment permitted hereunder shall permit the delivery of Supplemental Water to any property or development other than the Property without the written consent of the City, in its sole and absolute discretion.

32. **Opinions and Determinations: Good Faith.** Where the terms of this Agreement provide for action to be based upon opinion, judgment, approval, review or determination of either party hereto, such terms are not intended to and shall never be construed to permit such opinion, judgment, approval, review or determination to be arbitrary, capricious or unreasonable. The District and the NCSD shall each act in good faith in performing their respective obligations as set forth in this Agreement.

33. **Incorporation of Recitals.** Recitals A through F are incorporated herein by reference as though set forth at length.

34. **Attorneys Fees.** In the event that any legal proceeding other than the dispute resolution procedures referenced in Paragraph 19, above, is brought to enforce one or more of the terms of this Agreement, to restrain an alleged violation of this Agreement, or to determine the validity of this Agreement or any part, the prevailing Party in any such action or proceeding shall be entitled to recover from the other its reasonable costs and attorneys' fees, in addition to any other remedies available to it in law or equity. If both Parties are successful in one or more causes of action during any such proceeding, the costs and fees shall be apportioned as determined by the court.

35. **Governing Law and Venue.** This Agreement is a contract governed in accordance with the laws of the State of California. THE PARTIES HEREBY AGREE THAT VENUE FOR ANY ACTION BROUGHT TO ENFORCE THE TERMS OF THIS AGREEMENT SHALL BE IN A COURT OF COMPETENT JURISDICTION IN THE COUNTY OF SANTA BARBARA OTHER THAN A COURT LOCATED WITHIN THE

CITY OF SANTA MARIA OR THE NORTHERN PORTION OF SANTA BARBARA COUNTY, CALIFORNIA, AND CONSENT TO THE JURISDICTION THEREOF.

IN WITNESS WHEREOF, the Parties have executed this agreement as of the date first written above.

**CITY:**

**NCSD:**

City of Santa Maria  
a California municipal corporation

Nipomo Community Services District  
a California public agency

By:   
Name: Richard G. Sweet, P.E.  
Title: Director of Utilities

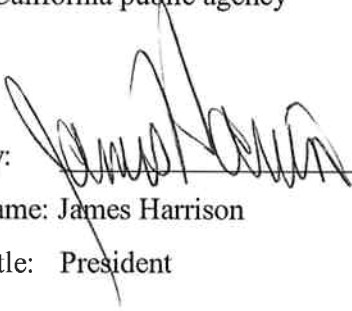
By:   
Name: James Harrison  
Title: President

Address: 2065 E. Main Street  
Santa Maria, CA 93454

Address: P.O. Box 326  
Nipomo, CA 93444

Fax: (805) 928-7240

Fax: (805) 929-1932

Phone: (805) 925-0951

Phone: (805) 929-1133

APPROVED AS TO FORM:

APPROVED AS TO FORM:

Best Best & Krieger LLP

District Counsel

By:   
Eric Garner, Partner

By:   
Jon Seitz, District Counsel